



# UNITIZATION PROCEDURES\* FOR STANDARD 12 INCH X 56 INCH SIN- GLE ROUND CONTAINERS (SRC) ON 4-WAY ENTRY PALLETS

\* CAUTION: THE PROCEDURES DEPICTED HEREIN ARE FOR INTRA-INSTALLATION MOVEMENT ONLY.

DISTRIBUTION STATEMENT A:

APPROVED FOR PUBLIC RELEASE  
DISTRIBUTION IS UNLIMITED.

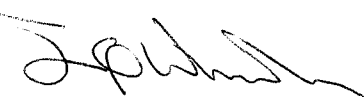
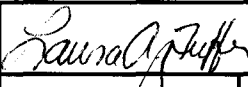
## U.S. ARMY MATERIEL COMMAND DRAWING

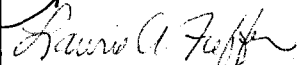
 <b>WM. TROOPER STUDDERT</b> CMA, NATIONAL MAINTENANCE POINT		<u>CAUTION</u> : VERIFY PRIOR TO USE AT WWW.DAC.ARMY.MIL THAT THIS IS THE MOST CURRENT VERSION OF THIS DOCUMENT. THIS IS PAGE 1 OF 6.		
		<b>DO NOT SCALE</b>		
APPROVED BY ORDER OF COMMANDING GENERAL, U.S. ARMY MATERIEL COMMAND   <b>U.S. ARMY DEFENSE AMMUNITION CENTER</b>		ENGINEER OR TECHNICIAN	BASIC MARK GRACE REV.	<b>DECEMBER 2005</b>
		TRANSPORTATION ENGINEERING DIVISION		
		VALIDATION ENGINEERING DIVISION		TESTED
		ENGINEERING DIRECTORATE		DRAWING  <b>DA-117/5</b>

## GENERAL NOTES

(GENERAL NOTES CONTINUED)

- A. THIS DOCUMENT HAS BEEN PREPARED AND ISSUED IN ACCORDANCE WITH AR 740-1 (CHAPTER 5) AND CONFORMS TO MIL-STD-1660.
- B. FOR DETAILS OF THE 12 INCH X 56 INCH SINGLE ROUND CONTAINER, SEE DAC DRAWING ACV00469.
- CONTAINER DIMENSIONS  
BASE OUTSIDE DIAMETER - - - 15.875"  
OVERALL LENGTH - - - - - 59.13"  
GROSS WEIGHT - - - - - 360 LBS (MAX)
- C. DIMENSIONAL LUMBER SPECIFIED THROUGHOUT THIS PROCEDURAL DRAWING IS OF A NOMINAL SIZE, UNLESS OTHERWISE SPECIFIED. FOR EXAMPLE, 1" X 4" MATERIAL IS ACTUALLY 3/4" THICK BY 3-1/2" WIDE AND 2" X 4" MATERIAL IS ACTUALLY 1-1/2" THICK BY 3-1/2" WIDE.
- D. UNLESS OTHERWISE SPECIFIED, A PLUS OR MINUS 1/4" IS ALLOWED ON OVERALL LENGTH AND WIDTH DIMENSIONS OF ANY DUNNAGE ASSEMBLY. HOWEVER, SIMILAR PIECES IN AN ASSEMBLY MUST BE WITHIN 1/8" OF THE SAME DIMENSION. FOR THICKNESS DIMENSIONS, A PLUS ZERO, MINUS 1/8" IS ALLOWED.
- E. WHEN ASSEMBLING A PALLET UNIT, CARE SHALL BE TAKEN TO ENSURE THAT THE ASSEMBLIES ARE EVENLY ALIGNED HORIZONTALLY AND VERTICALLY SO THAT THE SIDES AND ENDS OF THE PALLET UNIT DO NOT EXCEED A 1/2" TOLERANCE.
- F. DIMENSIONS GIVEN FOR DUNNAGE ASSEMBLIES WILL BE FIELD CHECKED PRIOR TO THEIR ASSEMBLY. CONTAINERS MUST FIT SNUGLY IN THE DUNNAGE ASSEMBLIES. THIS GUIDANCE MUST BE APPLIED PRIOR TO BEGINNING A PALLETIZING OPERATION. ALSO, DUE TO VARIATION OF CONTAINER DIMENSIONS AND CONTAINER HANDLES, ADJUSTMENTS MAY BE REQUIRED AS TO THE LOCATION OF CERTAIN PIECES ON SOME DUNNAGE ASSEMBLIES.
- G. THE FOLLOWING AMC DRAWINGS ARE APPLICABLE FOR OUTLOADING AND STORAGE OF THE ITEMS COVERED BY THIS DRAWING.
- ON-INSTALLATION MOVEMENT - - - 19-48-4306-5-1101000  
STORAGE - - - - - 19-48-4515-CB1-14-22P4
- H. WHEN INSTALLING THE TOP ASSEMBLY ON THE PALLET UNIT, CARE SHOULD BE EXERCISED TO PRECLUDE INTERFERENCE WITH THE CONTAINER HANDLES. THE COVER ASSEMBLY HAS BEEN DESIGNED SO THAT THE HANDLES WILL FIT IN THE SLOTS IN THE TOP ASSEMBLY IF CORRECTLY ALIGNED.
- J. PALLET UNITIZATION LOAD STRAPS AND TIEDOWN STRAPS ARE REQUIRED FOR "ON SITE CONTAINER" INTRA DEPOT TRANSPORT. PALLET UNITS WILL BE ASSEMBLED AS SHOWN ON PAGE 3. SIDEWALL, ENDWALL, DIVIDER RETAINER AND TOP ASSEMBLIES ARE TO BE SECURED WITH WOOD LAG SCREWS AS DESCRIBED IN "PALLET UNIT ASSEMBLY" DETAIL ON PAGE 4.

(CONTINUED AT RIGHT)

## MATERIAL SPECIFICATIONS

- LUMBER - - - - - : SEE TM 743-200-1 (DUNNAGE LUMBER) AND VOLUNTARY PRODUCT STANDARD PS 20.
- NAILS - - - - - : ASTM F1667: COMMON STEEL NAIL (NLCMS OR NLCMMS) AND PALLET NAIL (NLPL-03). ALT (FOR COMMON NAILS ONLY): UNDERLAYMENT NAIL (NLUL), PALLET NAIL (NLPL), OR COOLER NAIL (NLCL) OF SAME SIZE.
- PALLET - - - - - : MIL SPEC MIL-P-15011; 4-WAY ENTRY, STYLE 1, TYPE I, CLASS 1, PRESERVATIVE TREATED.
- PLYWOOD - - - - - : COMMERCIAL ITEM DESCRIPTION A-A-55057. INDUSTRIAL PLYWOOD, INTERIOR WITH EXTERIOR GLUE, GRADE C-D. IF SPECIFIED GRADE IS NOT AVAILABLE, A BETTER INTERIOR OR AN EXTERIOR GRADE MAY BE SUBSTITUTED.
- WOOD SCREW, LAG - - : COMMERCIAL GRADE; HEX HEAD WOOD SCREW, ZINC PLATE FINISH, LAG SCREW.
- WASHER - - - - - : COMMERCIAL GRADE; WASHER, PLAIN, FLAT, ZINC PLATE FINISH.
- STRAPPING, STEEL - - : ASTM D3953; FLAT STRAPPING, TYPE 1, HEAVY DUTY, FINISH B (GRADE 2), SIZE 3/4" X .035" OR .031". NOTE: BRIGHT OR SLIT EDGES SHALL HAVE FINISH A OVERLAY.
- SEAL, STRAP - - - - : ASTM D3953; CLASS H, FINISH B (GRADE 2), DOUBLE NOTCH TYPE, STYLE I, II, III, OR IV. ALTERNATIVE SEAL FINISH: SIGNODE PAINTED SEALS MAY BE USED AS AN ALTERNATIVE IF ALL SURFACES ARE PAINTED. GRITTED BACKING IS NOT PERMITTED.

- K. IN ORDER TO OBTAIN COMPACT (SOUND) UNITS, ALL STRAPS SHALL BE LOCATED IN PROPER ALIGNMENT AND TENSIONED UNTIL THEY CUT INTO THE EDGE OF THE DUNNAGE ASSEMBLIES AND THE PALLET DECK. AFTER TENSIONING, ALL STRAPS WILL BE SECURED USING ONE SEAL AND TWO PAIR OF NOTCHES PER SEAL. ALL STRAPPING MUST BE STRAIGHT WITHIN 2" ON ANY SURFACE OF THE UNITIZED LOAD I.E., TOP, BOTTOM, SIDES, OR ENDS THAT IT ENCOMPASSES.
- L. WHEN APPLYING ANY STRAP, CARE MUST BE EXERCISED TO ASSURE THAT THE END OF THE STRAP ON THE UNDERSIDE OF THE JOINT EXTENDS AT LEAST 6" BEYOND THE SEAL. THIS EXTRA MINIMUM LENGTH OF STRAP IS REQUIRED TO PERMIT SUBSEQUENT TIGHTENING OF LOOSENED STRAPPING. RETENSIONING CAN BE ACCOMPLISHED WITHOUT REPLACING STRAPPING OR SPLICING STRAPPING THROUGH THE USE OF A MANUAL OR PNEUMATIC FEEDWHEEL TYPE TENSIONING TOOL AND THE APPLICATION OF ONE ADDITIONAL SEAL.
- M. THE LOAD STRAPS MAY BE THREADED THROUGH THE STRAP SLOTS OF A PALLET OR PRE-POSITIONED ON THE PALLET DECK PRIOR TO PLACING THE BASE ASSEMBLY ON THE PALLET. LOAD STRAPS MUST BE TENSIONED AND SEALED PRIOR TO APPLICATION OF TIEDOWN STRAPS.
- N. INSTALL EACH TIEDOWN STRAP TO PASS UNDER THE TOP DECK BOARDS OF THE PALLET. NOTE THAT THE STRAPS WILL BE LOCATED AS SHOWN. TIEDOWN STRAPS WILL NOT BE APPLIED UNTIL THE LOAD STRAPS HAVE BEEN TENSIONED AND SEALED.
- O. THE STYLE 1 PALLET DELINEATED IN THE DETAIL ON PAGE 3 NEED NOT HAVE CHAMFERS OR STRAP SLOTS AS SPECIFIED WITHIN MILITARY SPECIFICATION MIL-P-15011 WHEN USED FOR THE UNITIZATION OF ITEMS COVERED BY THIS DRAWING.
- P. LESS-THAN-FULL PALLET UNITS SHOULD HAVE THE CONTAINERS CENTERED ON THE PALLET TO BALANCE THE LOAD.
- Q. CONVERSION TO METRIC EQUIVALENTS: DIMENSIONS WITHIN THIS DOCUMENT ARE EXPRESSED IN INCHES AND WEIGHTS ARE EXPRESSED IN POUNDS. WHEN NECESSARY, THE METRIC EQUIVALENTS MAY BE COMPUTED ON THE BASIS OF ONE INCH EQUALS 25.4MM, AND ONE POUND EQUALS 0.454 KG.
- R. IF LEAKING OR SUSPECT ITEMS COVERED HEREIN ARE UNITIZED PRIOR TO ISSUANCE OF THIS REVISION TO THIS APPENDIX, THE CONTAINERS NEED NOT BE REUNITIZED SOLELY TO CONFORM TO THIS REVISION.
- S. CAUTION: DO NOT STACK PALLET UNITS ONE ON TOP OF ANOTHER IN STORAGE OR IN TRANSPORT.

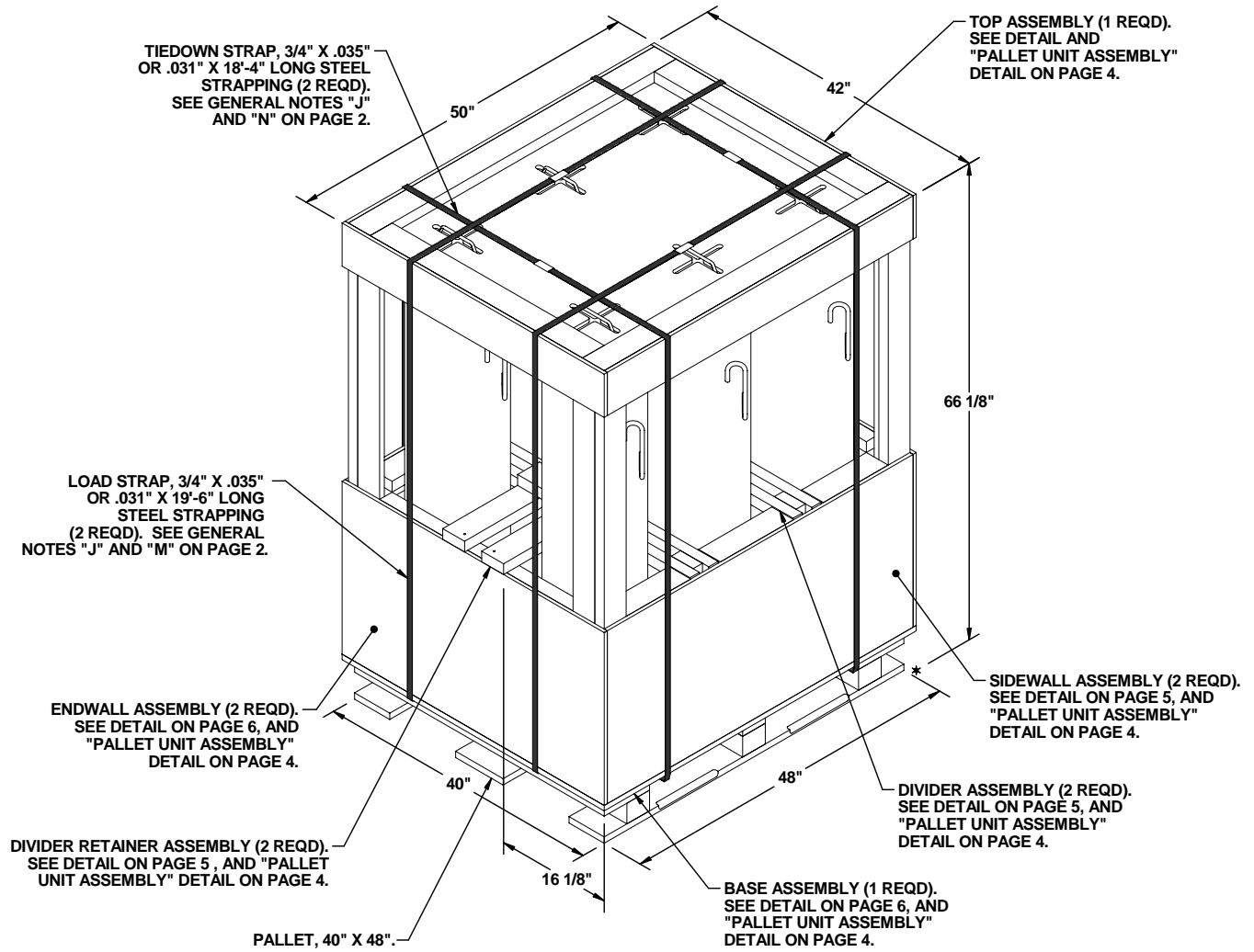

**PALLET UNIT**

6 12 INCH X 56 INCH SRCs @ 360 LBS	-----	2,160 LBS
DUNNAGE	-----	244 LBS
PALLET	-----	80 LBS

TOTAL WEIGHT ----- 2,484 LBS (APPROX)  
 CUBE ----- 80.4 CU FT (APPROX)

BILL OF MATERIAL		
LUMBER	LINEAR FEET	BOARD FEET
1" X 4"	26.25	8.75
1" X 6"	4.08	2.04
2" X 2"	42.92	17.75
2" X 4"	56.50	35.67
NAI LS	NO. REQD	POUNDS
6d (2")	118	3/4
10d (3")	96	1-1/2
LAG SCREWS	NO. REQD	POUNDS
1/4" X 1-1/2"	28	1/2
1/4" X 2-1/2"	4	NIL
WASHERS	NO. REQD	POUNDS
1/4" FLAT	32	NIL
PALLET, 40" X 48"	1 REQD	80 LBS
STEEL STRAPPING, 3/4"	80.75' REQD	7.25 LBS
SEAL FOR 3/4" STRAPPING	4 REQD	NIL
PLYWOOD, 1/2"	51.87 SQ FT REQD	71.32 LBS
PLYWOOD, 3/4"	14.58 SQ FT REQD	30.08 LBS

SECURE ENDWALL AND TOP ASSEMBLIES TO SIDEWALL ASSEMBLY W/8 1/4" DIA X 1-1/2" LONG LAG SCREWS WITH WASHERS. PREDRILL 3/16" HOLES TO REDUCE SPLITTING.

MARK COMPONENT CORNER WITH PAINT TO ENSURE SCREW HOLE ALIGNMENT WHEN PALLET UNIT IS DISASSEMBLED AND REASSEMBLED.

SECURE RETAINER ASSEMBLY TO ENDWALL W/4 1/4" DIA X 2-1/2" LONG LAG SCREWS WITH WASHERS. PREDRILL 3/16" HOLES IN ENDWALL TO REDUCE SPLITTING.

NAIL BASE ASSEMBLY TO PALLET W/8-6d NAILS.

MARK ONE COMPONENT CORNER WITH PAINT TO ENSURE SCREW HOLE ALIGNMENT WHEN PALLET UNIT IS DISASSEMBLED AND REASSEMBLED.

SECURE SIDEWALL ASSEMBLIES TO BASE ASSEMBLY EDGE LOCATORS W/6 1/4" DIA X 1-1/2" LONG LAG SCREWS WITH WASHERS. PREDRILL 3/16" HOLES TO REDUCE SPLITTING.

**PALLET UNIT ASSEMBLY**

MARK THE PALLET UNIT AT TIME OF ASSEMBLY. APPLY COLOR MARKINGS TO ANY TWO ADJACENT CORNERS OF ASSEMBLED PALLET UNIT TO AID IN DISASSEMBLY AND REASSEMBLY. MAJOR COMPONENTS ARE: BASE, SIDEWALL, ENDWALL, DIVIDER RETAINER AND TOP ASSEMBLIES. SEE GENERAL NOTES "J" THROUGH "N" ON PAGE 2 FOR STEEL STRAP REQUIREMENTS.

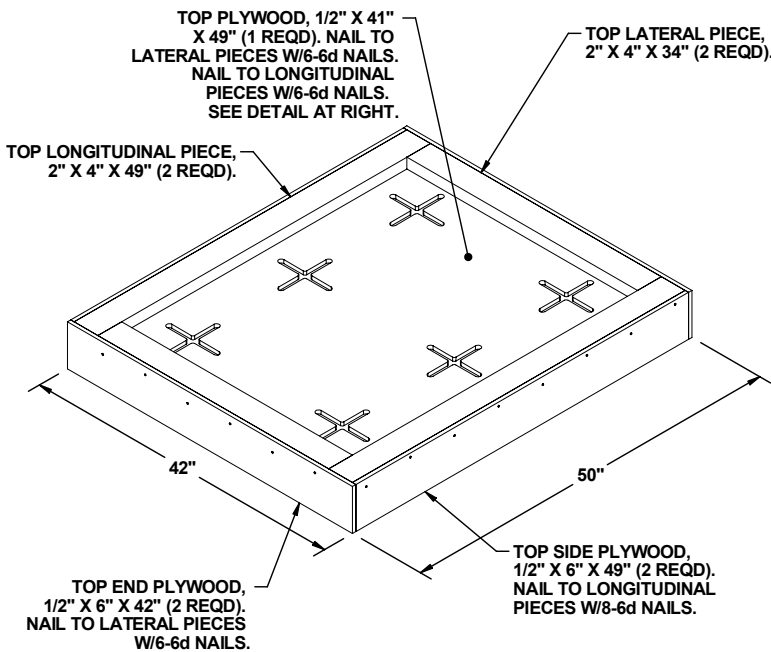

**TOP ASSEMBLY**

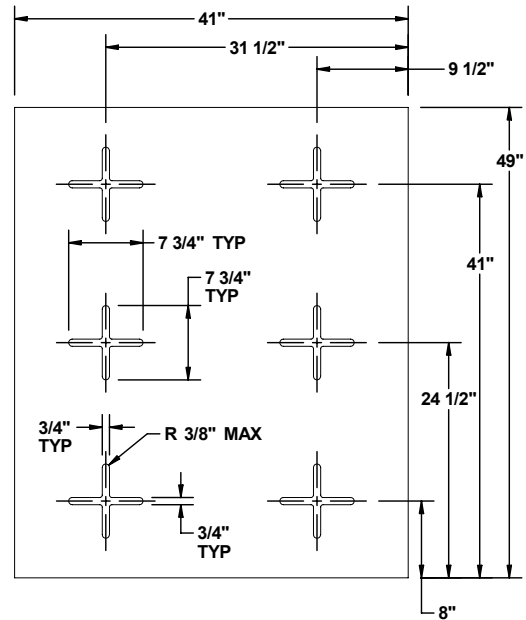

**TOP PLYWOOD**



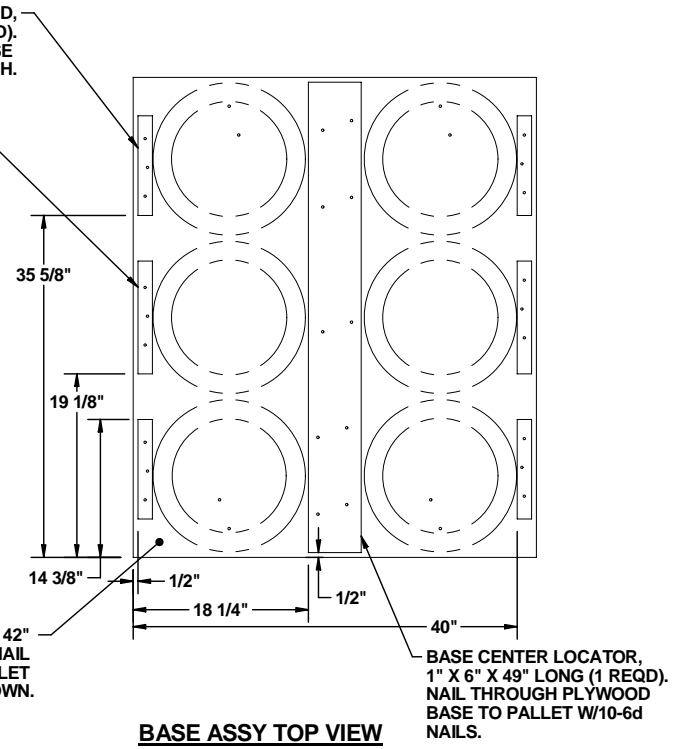
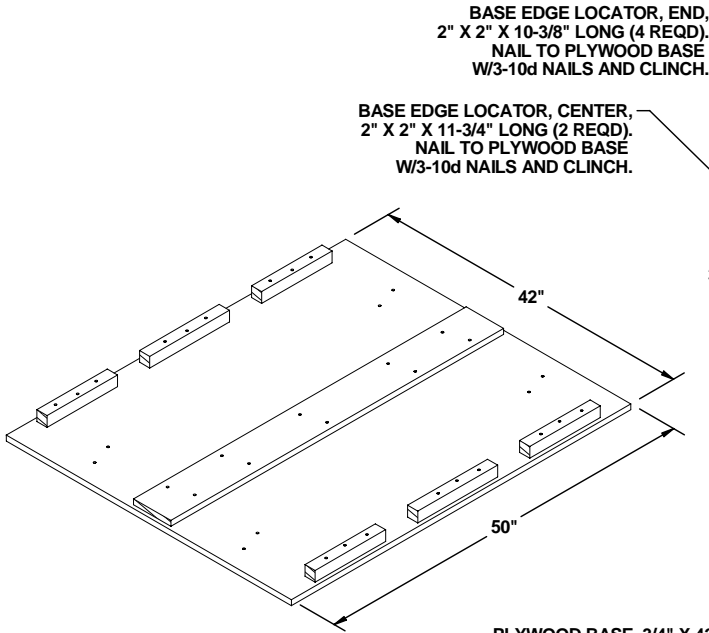

**BASE ASSEMBLY**

