

APPROVED BY U.S. COAST GUARD <i>L.H. Wilson</i>	APPROVED BY BUREAU OF EXPLOSIVES <i>M. R. Miller</i> SUPERVISOR, MILITARY & INTERMODAL SERVICES
DATE <i>6/4/80</i>	DATE <i>5/20/80</i>

LOADING AND BRACING WITH WOODEN DUNNAGE IN COMMERCIAL CONTAINERS OF SKIDDED UNITS OF CRYPTOGRAPHIC EQUIPMENT DESTROYERS (22-BOX SKIDDED UNIT) (WOODEN BOX)

THE DEPICTED WOODEN DUNNAGE METHOD CAN BE APPLIED TO ANY COMMERCIAL INTERMODAL 20-FOOT CONTAINER, ALTHOUGH THE DUNNAGE DIMENSIONS HAVE BEEN GIVEN FOR A 92" WIDE BY 95" HIGH (INSIDE DIMENSIONS) CONTAINER. ALTHOUGH THE LOAD AS SHOWN IS BASED ON AN 8'-6" HIGH CONTAINER, AN 8'-0" HIGH CONTAINER IS PREFERRED FOR SHIPPING THE DEPICTED LOAD. WHEN AN 8'-0" HIGH CONTAINER IS USED, THE HEIGHT OF SOME DUNNAGE ASSEMBLIES WILL HAVE TO BE LOWERED BY REMOVING SOME MATERIAL FROM THE TOP OR BOTTOM OF SOME OF THE VERTICAL PIECES.

LOADING AND BRACING SPECIFICATIONS AS DELINEATED HEREIN ARE ADEQUATE FOR SHIPMENTS TO BE MOVED BY ANY SURFACE MODE OF TRANSPORT (MOTOR, RAIL, AND WATER).

REQUIREMENTS CITED WITHIN THE BUREAU OF EXPLOSIVES PAMPHLET 6C APPLY WHEN THE SHIPMENT MOVES BY TRAILER/CONTAINER-ON-FLAT-CAR (T/COFC). SPECIAL T/COFC NOTES FOLLOW.

- A. A LOADED CONTAINER MUST BE ON A CHASSIS EQUIPPED WITH TWO BOGIE ASSEMBLIES WHEN BEING MOVED IN TOFC SERVICE.
- B. THE LOAD LIMIT OF A T/COFC RAIL CAR MUST NOT BE EXCEEDED, NOR WILL A CAR BE LOADED SO THAT THE TRUCK UNDER ONE END OF THE CAR CARRIES MORE THAN ONE-HALF OF THE LOAD LIMIT FOR THAT CAR.

DURING INTRASTATE AND/OR INTERSTATE MOVES BY MOTOR CARRIER, A PROPER CHASSIS/MODIFIED FLAT BED TRAILER MUST BE USED TO PRECLUDE VIOLATION OF ONE OR MORE "WEIGHT LAWS" APPLICABLE TO THE STATE OR STATES INVOLVED.

DO NOT SCALE

REVISIONS		BRW/MS	PROJ ENG
		<i>Box</i>	<i>WRP/LES</i>
		CHECKER	LOS ENGINE OFFICE
		<i>RSP</i>	<i>M. Miller</i>
APPROVED, U. S. ARMY ARMAMENT MATERIAL READINESS COMMAND			
<i>Carol P. Feltus</i>			
APPROVED BY ORDER OF COMMANDING GENERAL, U. S. ARMY MATERIAL DEVELOPMENT AND READINESS COMMAND (DARCOM)			
<i>John L. Reynolds</i>			
U. S. ARMY DEFENSE AMMUNITION CENTER AND SCHOOL			
U. S. ARMY DARCOM DRAWING			
JULY 1980			
DEF AMMO GEN & SCH DWG NO			
D-SARAC-4455			

INDICATES A SKIDDED UNIT. SEE THE "SKIDDED UNIT" DETAIL ON PAGE 6 FOR THE SPECIFIC UNIT CONFIGURATION AND OTHER PERTINENT DATA.

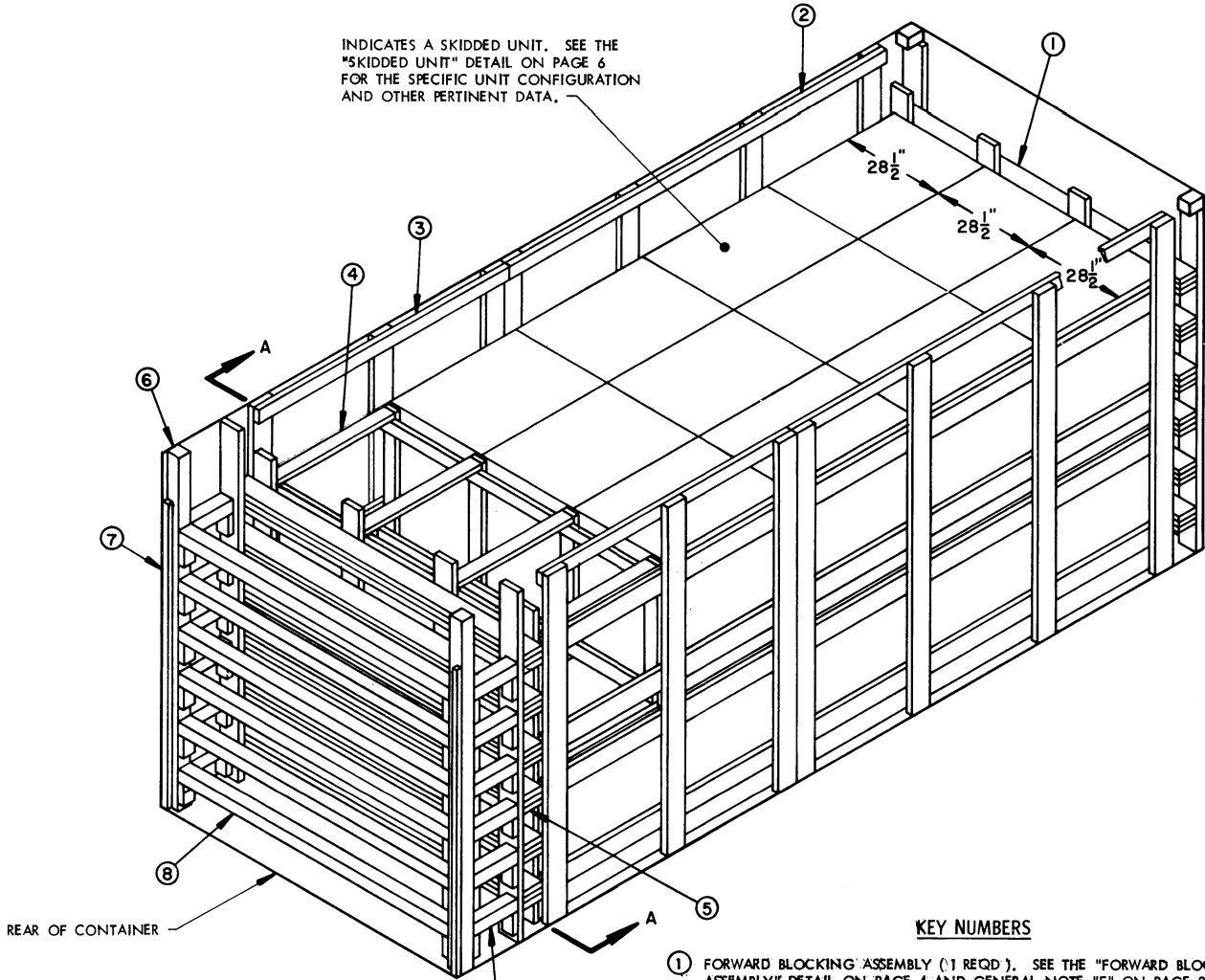

ISOMETRIC VIEW

KEY NUMBERS

- ① FORWARD BLOCKING ASSEMBLY (1 REQD). SEE THE "FORWARD BLOCKING ASSEMBLY" DETAIL ON PAGE 4 AND GENERAL NOTE "F" ON PAGE 3.
- ② SIDE FILL ASSEMBLY A (2 REQD). SEE THE "SIDE FILL ASSEMBLY A" DETAIL ON PAGE 5 AND GENERAL NOTE "D" ON PAGE 3.
- ③ SIDE FILL ASSEMBLY B (2 REQD). SEE THE "SIDE FILL ASSEMBLY B" DETAIL ON PAGE 5 AND GENERAL NOTE "D" ON PAGE 3.
- ④ FILLER ASSEMBLY (1 REQD). SEE THE "FILLER ASSEMBLY" DETAIL ON PAGE 6.
- ⑤ REAR BLOCKING ASSEMBLY (1 REQD). SEE THE "REAR BLOCKING ASSEMBLY" DETAIL ON PAGE 4 AND GENERAL NOTE "F" ON PAGE 3.
- ⑥ DOOR POST VERTICAL (2 REQD). SEE THE "DOOR POST VERTICAL" DETAIL AND "DETAIL A" ON PAGE 7.
- ⑦ DOOR POST VERTICAL RETAINER (2 REQD). SEE THE "DOOR POST VERTICAL RETAINER" DETAILS ON PAGE 8 AND "DETAIL A" ON PAGE 7. NAIL THROUGH THE HOLES INTO THE DOOR POST VERTICAL W/4-10d NAILS.
- ⑧ DOOR SPANNER 4" X 4" MATERIAL, CUT TO A LENGTH THAT WILL PROVIDE FOR A DRIVE FIT (REF: 7'-1-3/8") (6 REQD). TOENAIL TO THE DOOR POST VERTICALS W/2-12d NAILS AT EACH END. SEE THE "BEVEL-CUT" DETAIL ON PAGE 7. AFTER INSTALLING THE BOTTOM AND THE TOP DOOR SPANNERS, THE STRUTS, PIECES MARKED ⑨, ARE TO BE INSTALLED.
- ⑨ STRUT, 4" X 4" BY CUT-TO-FIT (12 REQD). TOENAIL TO THE BUFFER PIECES OF THE REAR BLOCKING ASSEMBLY AND THE DOOR POST VERTICAL W/2-12d NAILS AT EACH END. SEE THE "BEVEL-CUT" DETAIL ON PAGE 7.

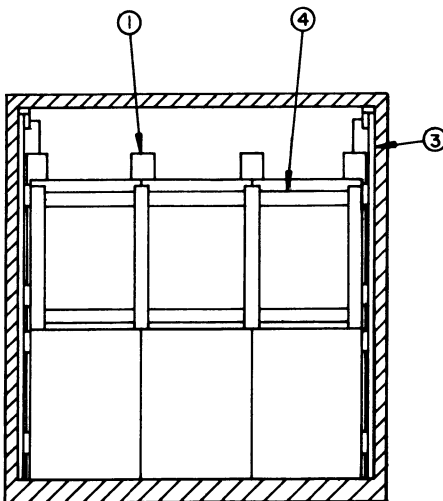

SECTION A-A

(GENERAL NOTES CONTINUED)

GENERAL NOTES

L. RECOMMENDED SEQUENTIAL LOADING PROCEDURES:

1. PREFABRICATE ONE FORWARD BLOCKING ASSEMBLY, FOUR SIDE FILL ASSEMBLIES, ONE FILLER ASSEMBLY, ONE REAR BLOCKING ASSEMBLY, AND NAIL A DOOR POST VERTICAL RETAINER TO EACH DOOR POST VERTICAL, ONE RIGHT HAND AND ONE LEFT HAND.
2. INSTALL FORWARD BLOCKING ASSEMBLY.
3. INSTALL TWO SIDE FILL ASSEMBLIES "A" AND LOAD EIGHTEEN SKIDDED UNITS.
4. INSTALL TWO SIDE FILL ASSEMBLIES "B" AND LOAD SIX SKIDDED UNITS.
5. LOAD THE REMAINING THREE SKIDDED UNITS AND INSTALL FILLER ASSEMBLY.
6. INSTALL REAR BLOCKING ASSEMBLY.
7. INSTALL THE TWO DOOR POST VERTICAL ASSEMBLIES (ONE RIGHT HAND AND ONE LEFT HAND).
8. INSTALL TWO DOOR SPANNER PIECES (ONE AT THE LOWEST POSITION AND ONE AT THE UPPERMOST POSITION).
9. INSTALL THE STRUTS BETWEEN REAR BLOCKING ASSEMBLY AND THE DOOR POST VERTICALS.
10. INSTALL THE REMAINING FOUR DOOR SPANNER PIECES STARTING WITH THE LOWEST AND WORKING UPWARD.

- A. THIS DOCUMENT HAS BEEN PREPARED AND ISSUED IN ACCORDANCE WITH AR 740-1, AND AUGMENTS TM 743-200-1 (CHAPTER 5).
- B. THE SPECIFIED OUTLOADING PROCEDURE IS APPLICABLE TO A LOAD OF 22-BOX SKIDDED UNITS OF CRYPTOGRAPHIC EQUIPMENT DESTROYERS PACKED IN WOODEN BOXES. SUBSEQUENT REFERENCE TO SKIDDED UNIT MEANS THE SKIDDED UNIT WITH AMMUNITION ITEMS. SEE PAGE 6 FOR THE DETAIL OF THE SKIDDED UNIT. CAUTION: REGARDLESS OF THE QUANTITY OF UNITS TO BE SHIPPED, THE "MAXIMUM GROSS WEIGHT" OF 44,800 POUNDS MUST NOT BE EXCEEDED.
- C. THE LOAD AS SHOWN IS BASED ON A 4,700 POUND 20' LONG BY 8' WIDE BY 8'-6" HIGH INTERMODAL COMMERCIAL CONTAINER WITH INSIDE DIMENSIONS OF 19'-4" LONG BY 92" WIDE BY 95" HIGH. THE LOAD IS DESIGNED FOR TRAILER/CONTAINER-ON-FLAT-CAR (T/COFC) SHIPMENT, HOWEVER, THE LOAD AS DESIGNED CAN ALSO BE MOVED BY OTHER SURFACE MODES OF TRANSPORT. NOTICE: OTHER CONTAINERS OF THE SAME DESIGN CONFIGURATION CAN BE USED.
- D. WHEN LOADING SKIDDED UNITS, THEY ARE TO BE POSITIONED SO AS TO ACHIEVE A TIGHT LOAD (TIGHT AGAINST THE FORWARD AND SIDE DUNNAGE ASSEMBLIES). ALTHOUGH A TOTAL OF ONE AND ONE-HALF INCHES (1-1/2") OF UNBLOCKED SPACE ACROSS THE WIDTH OF A LOAD BAY IS PERMITTED, LATERAL VOIDS WITHIN THE LOAD ARE TO BE HELD TO A MINIMUM. EXCESSIVE SLACK CAN BE ELIMINATED FROM A LOAD BY LAMINATING ADDITIONAL PIECES OF APPROPRIATE THICKNESS TO THE BEARING PIECES ON THE SIDE FILL ASSEMBLIES ON ONE OR BOTH SIDES OF THE CONTAINER. NAIL EACH ADDITIONAL PIECE TO THE BEARING PIECE W/1 APPROPRIATELY SIZED NAIL EVERY 12". ADDITIONALLY, THE NUMBER AND THICKNESS OF THE BEARING PIECES AND THE THICKNESS OF THE VERTICAL PIECES MAY BE ADJUSTED AS REQUIRED TO FACILITATE VARIANCE IN THE WIDTH OF THE SKIDDED UNIT.
- E. DUNNAGE LUMBER SPECIFIED IS OF A NOMINAL SIZE. FOR EXAMPLE, 2" X 4" MATERIAL IS ACTUALLY 1-1/2" THICK BY 3-1/2" WIDE AND 2" X 6" MATERIAL IS ACTUALLY 1-1/2" THICK BY 5-1/2" WIDE.
- F. A STAGGERED NAILING PATTERN WILL BE USED WHEREVER POSSIBLE WHEN NAILS ARE DRIVEN INTO JOINTS OF DUNNAGE ASSEMBLIES OR WHEN LAMINATING DUNNAGE. ADDITIONALLY, THE NAILING PATTERN FOR AN UPPER PIECE OF LAMINATED DUNNAGE WILL BE ADJUSTED AS REQUIRED SO THAT A NAIL FOR THAT PIECE WILL NOT BE DRIVEN THROUGH ONTO OR RIGHT BESIDE A NAIL IN A LOWER PIECE.
- G. IN SOME CONTAINERS, SUCH AS SOME ALL STEEL CONTAINERS, THERE IS A SLOT AT THE CORNERS OF THE FORWARD WALL. A PIECE OF DUNNAGE MATERIAL MUST BE LAMINATED TO THE BUFFER PIECES ON THE FORWARD BLOCKING ASSEMBLY TO PROVIDE A FLAT SURFACE FOR THE 2" X 6" BUFFER PIECES. A PIECE OF 2" X 4", 2" X 3", OR A SPECIAL WIDTH PIECE CUT-TO-FIT CAN BE USED. THIS FILL PIECE WILL BE NAILED WITH ONE APPROPRIATELY SIZED NAIL EVERY 12". THIS PIECE IS NOT REQUIRED WHEN THE FRONT WALL OF THE CONTAINER IS SMOOTH AND FLAT.
- H. CAUTION: DO NOT NAIL DUNNAGE MATERIAL TO THE CONTAINER WALLS OR FLOOR. ALL NAILING WILL BE WITHIN THE DUNNAGE.
- J. PORTIONS OF THE CONTAINER DEPICTED WITHIN THIS DRAWING, SUCH AS ONE OF THE SIDE WALLS, HAVE NOT BEEN SHOWN IN THE LOAD VIEWS FOR CLARITY PURPOSES.
- K. TO MAKE LOADING EASIER, TO HELP ACHIEVE A TIGHT LOAD ACROSS A CONTAINER AND TO PREVENT UNACCEPTABLE DAMAGE TO LADING UNITS WHEN LOADING A CONTAINER, A SLIP-SHEET CAN BE USED EFFECTIVELY AS A "SHOE-HORN" TYPE DEVICE. THE SLIP-SHEET WILL PROVIDE A SMOOTH SURFACE THAT WILL PREVENT UNIT STRAPS AND/OR BOXES FROM INTERLOCKING OR CATCHING ON OTHER PROJECTIONS WHEN LATERALLY ADJACENT LADING UNITS ARE BEING LOADED. A SLIP-SHEET WILL BE USED AFTER ONE-HALF OF A STACK IS LOADED WITH ONE OF ITS SIDES IN TIGHT CONTACT AT ONE SIDE OF THE CONTAINER. THE SLIP-SHEET IS TO BE PLACED AGAINST THE OTHER SIDE OF THE HALF-STACK BEFORE THE LAST HALF OF THE STACK IS LOADED. AFTER A STACK IS COMPLETED, THE SLIP-SHEET IS TO BE REMOVED FOR SUBSEQUENT USE WITH THE NEXT STACK. A SLIP-SHEET OF SUITABLE SIZE CAN BE MADE FROM A SHEET OF 1/8" TEMPERED HARDBOARD (MASONITE) OR FROM A SHEET OF ANY OTHER MATERIAL THAT WILL SATISFY THE REQUIREMENT.

BILL OF MATERIAL		
LUMBER	LINEAR FEET.	BOARD FEET
2" X 4"	128	86
2" X 6"	600	600
4" X 4"	74	99
NAILS	NO. REQD	POUNDS
10d (3")	834	13
12d (3-1/4")	72	1-1/4
DOOR POST VERTICAL RETAINER ----- 2 REQD -----		64 LBS

(CONTINUED AT LEFT)

MATERIAL SPECIFICATIONS

- LUMBER -----: TM 743-200-1 (DUNNAGE LUMBER) AND FED SPEC MM-L-751.
- NAILS -----: FED SPEC FF-N-105; COMMON.
- STEEL, STRUCTURAL -----: FED SPEC QQ-S-741; SQUARE STRUCTURAL TUBING AND HOT-ROLLED STRIP.

LOAD AS SHOWN

ITEM	QUANTITY	WEIGHT (APPROX)
SKIDDED UNIT -----	27 -----	33,642 LBS
DUNNAGE -----	-----	1,649 LBS
CONTAINER -----	-----	4,700 LBS
TOTAL WEIGHT -----		39,991 LBS

BUFFER PIECE, 2" X 6" BY INSIDE CONTAINER HEIGHT MINUS 1/2" (REF: 7'-7-1/2") (2 REQD). NAIL TO THE BEAM ASSEMBLIES W/3-10d NAILS AT EACH JOINT.

SEE GENERAL NOTE "G" ON PAGE 3.

BEAM ASSEMBLY, 2" X 6" BY INSIDE CONTAINER WIDTH MINUS 1" (REF: 7'-7") (TRIPLED) (6 REQD). LAMINATE THE SECOND PIECE TO THE FIRST PIECE W/11-10d NAILS. LAMINATE THE THIRD PIECE TO THE SECOND PIECE IN A LIKE MANNER.

LOAD BEARING PIECE, 2" X 6" X 7'-0" (4 REQD). NAIL TO THE BEAM ASSEMBLIES W/3-10d NAILS AT EACH JOINT.

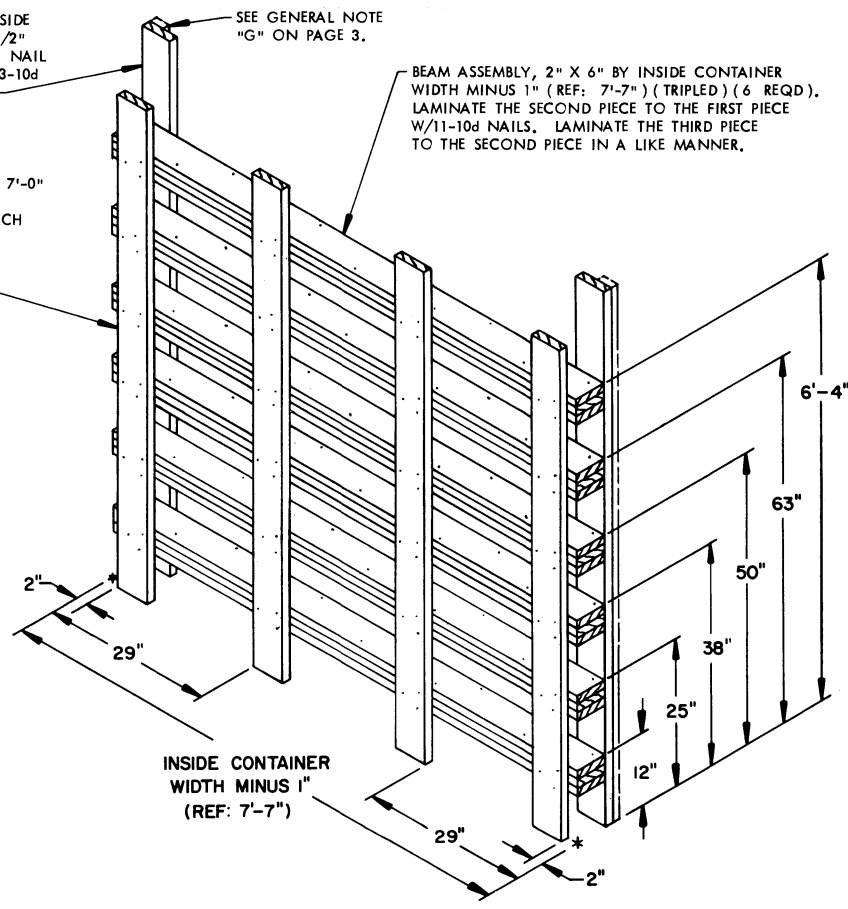

INSIDE CONTAINER WIDTH MINUS 1" (REF: 7'-7")

FORWARD BLOCKING ASSEMBLY

BUFFER PIECE, 2" X 6" BY INSIDE CONTAINER HEIGHT MINUS 1/2" (REF: 7'-10-1/2") (2 REQD). NAIL TO THE BEAM ASSEMBLIES W/3-10d NAILS AT EACH JOINT.

LOAD BEARING PIECE, 2" X 6" X 7'-0" (4 REQD). NAIL TO THE BEAM ASSEMBLIES W/3-10d NAILS AT EACH JOINT.

BEAM ASSEMBLY, 2" X 6" BY INSIDE CONTAINER WIDTH MINUS 1" (REF: 7'-7") (TRIPLED) (6 REQD). LAMINATE THE SECOND PIECE TO THE FIRST PIECE W/11-10d NAILS. LAMINATE THE THIRD PIECE TO THE SECOND PIECE IN A LIKE MANNER.

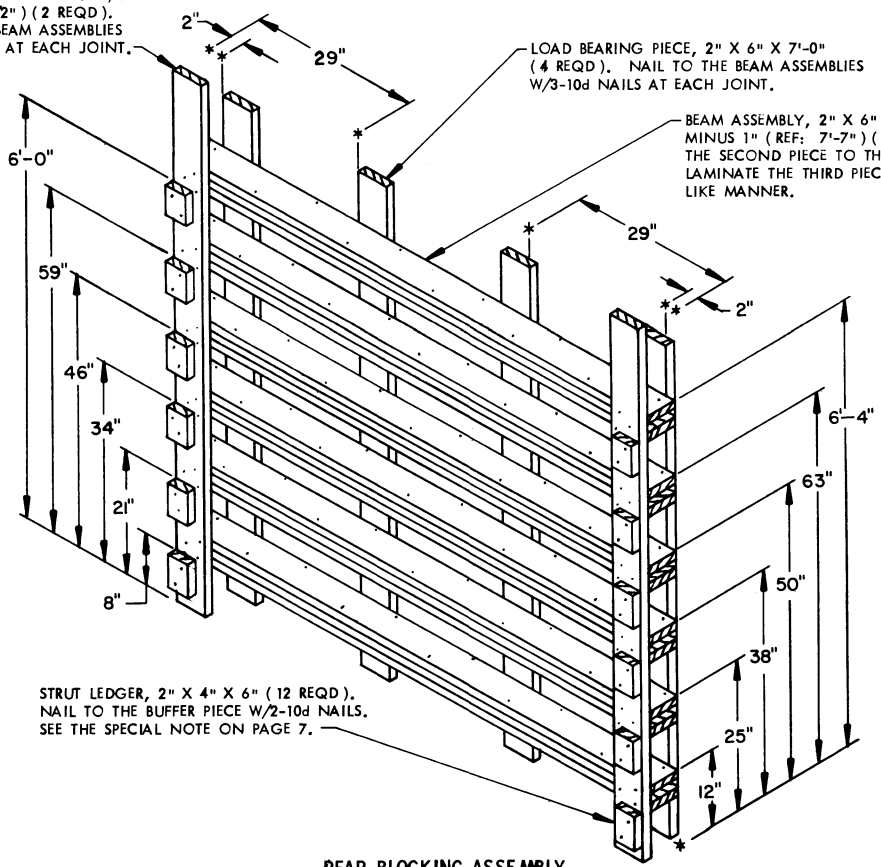

STRUT LEDGER, 2" X 4" X 6" (12 REQD). NAIL TO THE BUFFER PIECE W/2-10d NAILS. SEE THE SPECIAL NOTE ON PAGE 7.

REAR BLOCKING ASSEMBLY

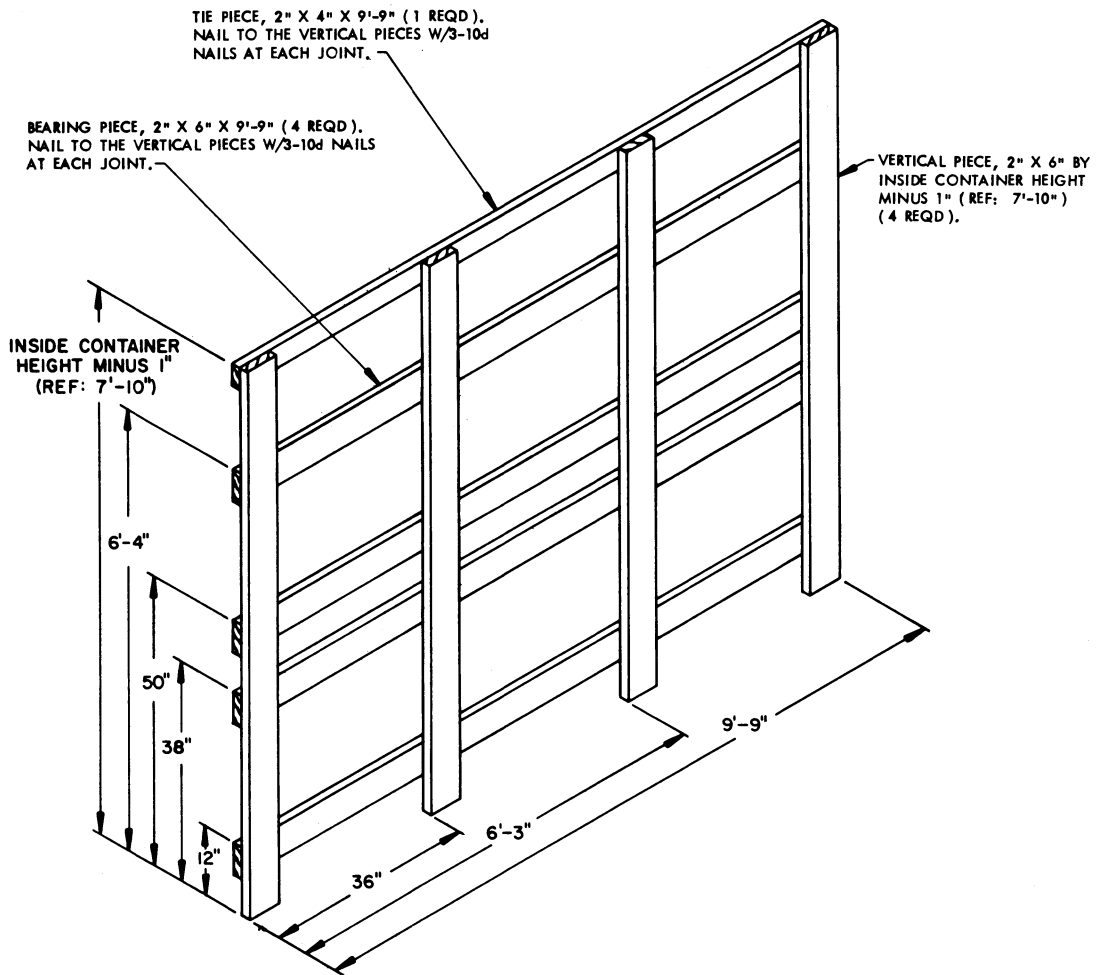

SIDE FILL ASSEMBLY A

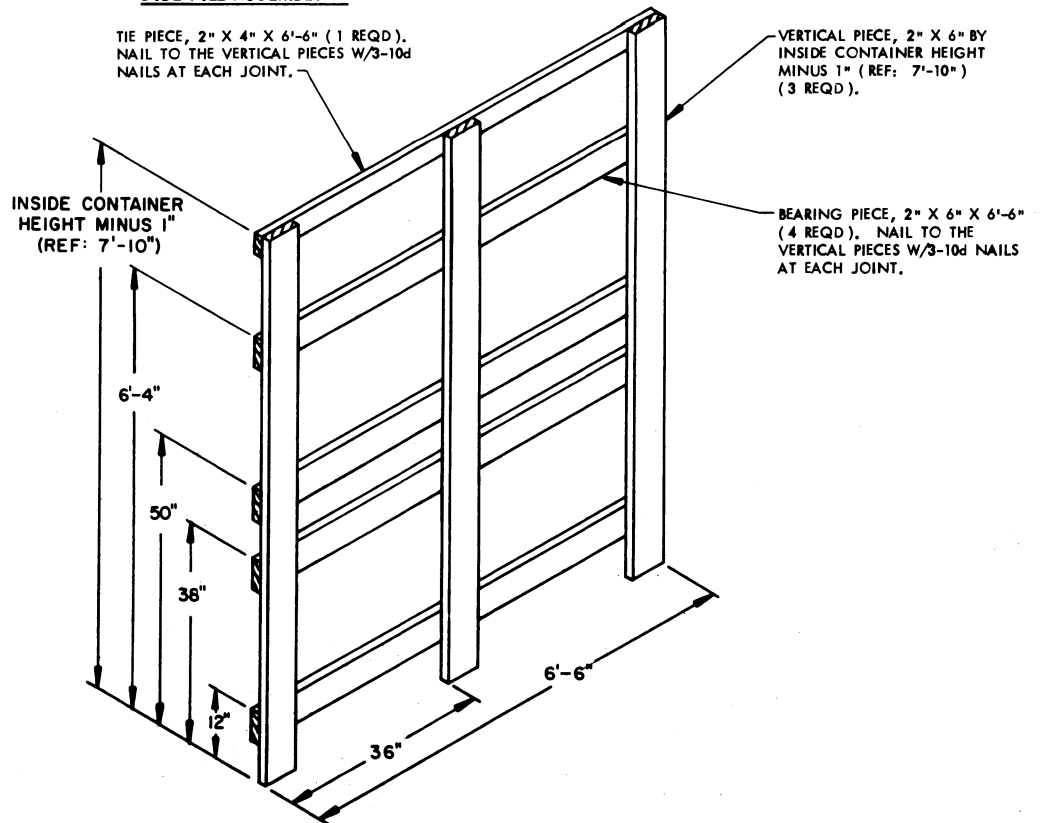

SIDE FILL ASSEMBLY B

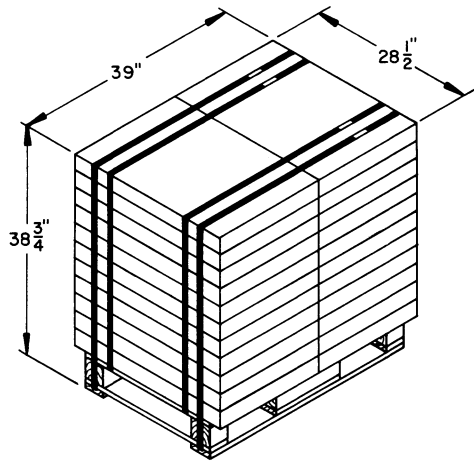

SKIDDED UNIT

UNIT WEIGHT ----- 1,246 LBS (APPROX)
 CUBE ----- 24.9 CUBIC FEET

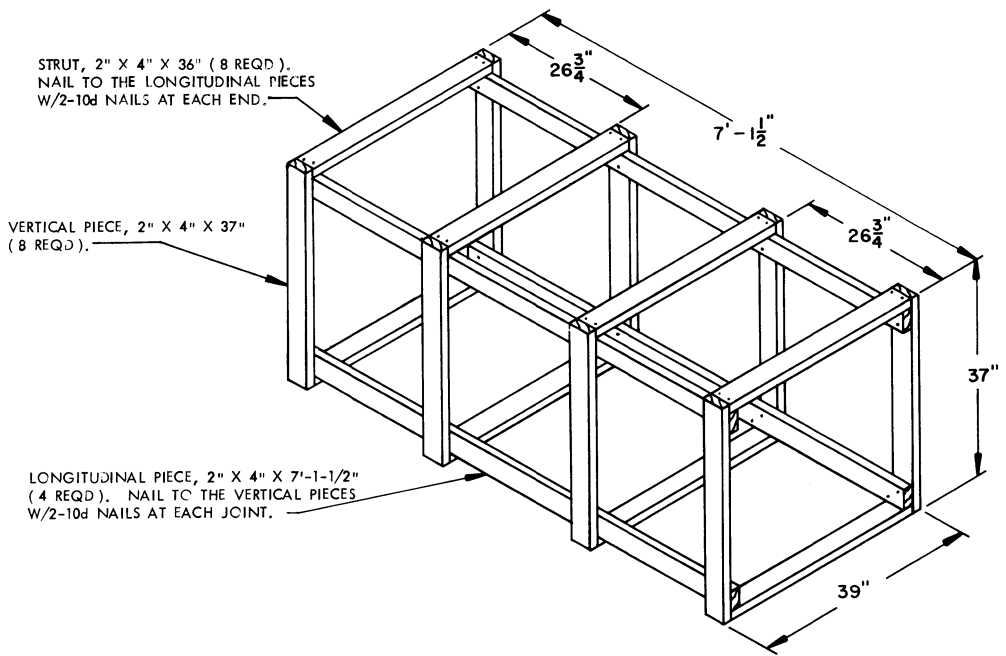

FILLER ASSEMBLY

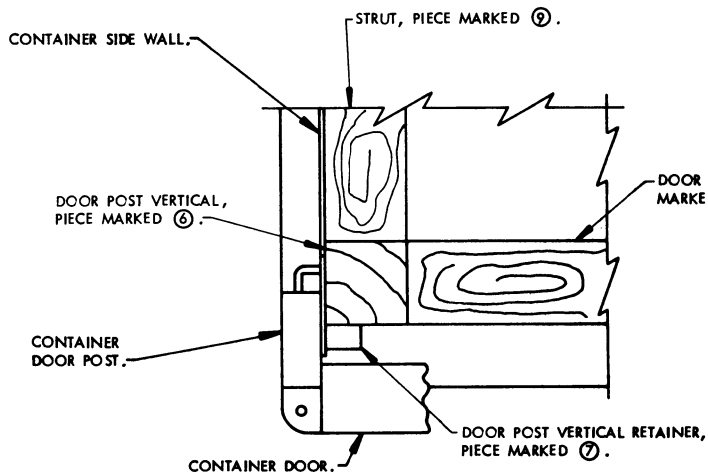

DETAIL A

A PARTIAL PLAN VIEW OF THE LEFT REAR PORTION OF THE CONTAINER IS SHOWN DEPICTING THE PROPER POSITION OF THE DOOR POST VERTICAL AND ADJACENT DUNNAGE PIECES.

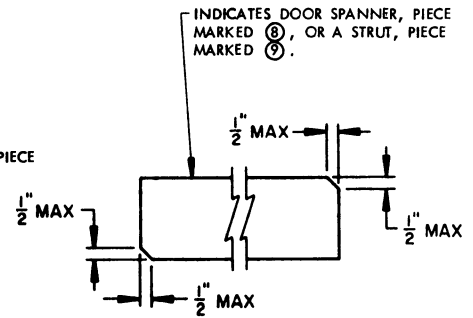

BEVEL-CUT

IF DESIRED, EACH END OF A DOOR SPANNER PIECE OR A STRUT MAY BE BEVEL-CUT AS SHOWN ABOVE TO FACILITATE THE ACHIEVEMENT OF A TIGHT DOOR-POST-TO-DOOR-POST FIT OR A TIGHT REAR-OF-LOAD FIT.

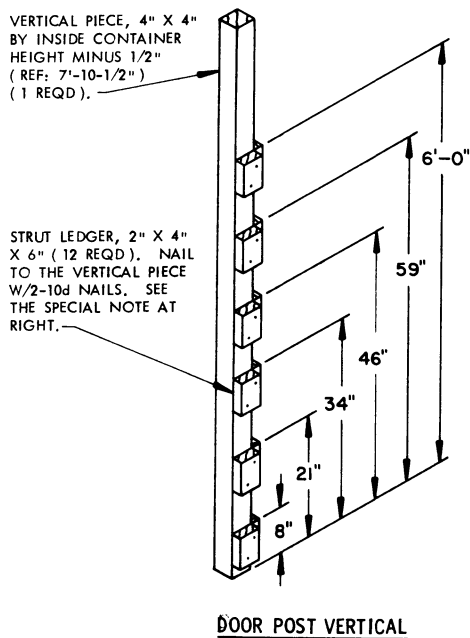

SPECIAL NOTE:

THE STRUT LEDGERS CAN ONLY BE PRE-NAILED TO THE DOOR POST VERTICAL ON ONE SIDE OF THE CONTAINER FOR THE DOOR SPANNER PIECES. ALSO, THE STRUT LEDGERS FOR THE STRUTS CAN ONLY BE PRE-NAILED TO THE REAR BLOCKING ASSEMBLY OR THE DOOR POST VERTICAL AT THE LOWEST POSITION.

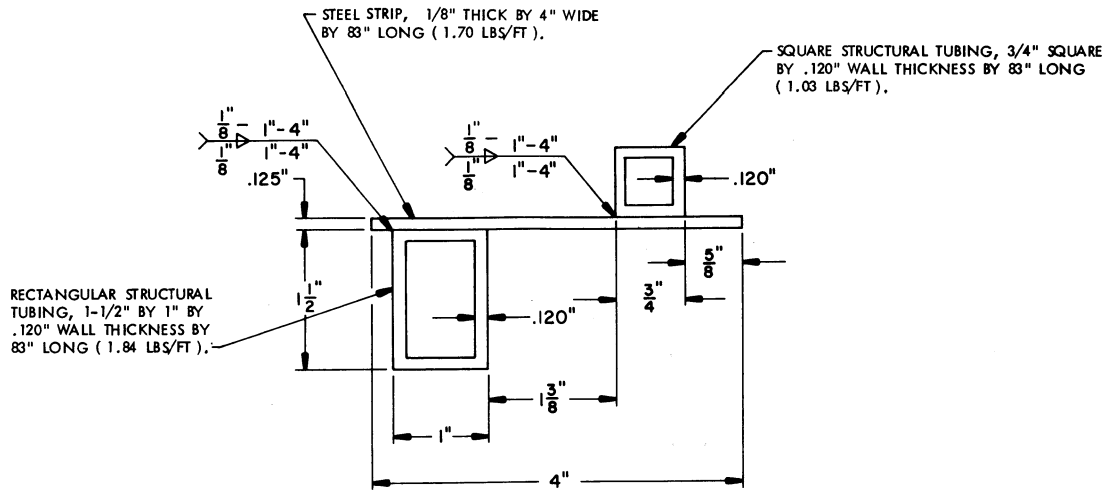

VIEW A

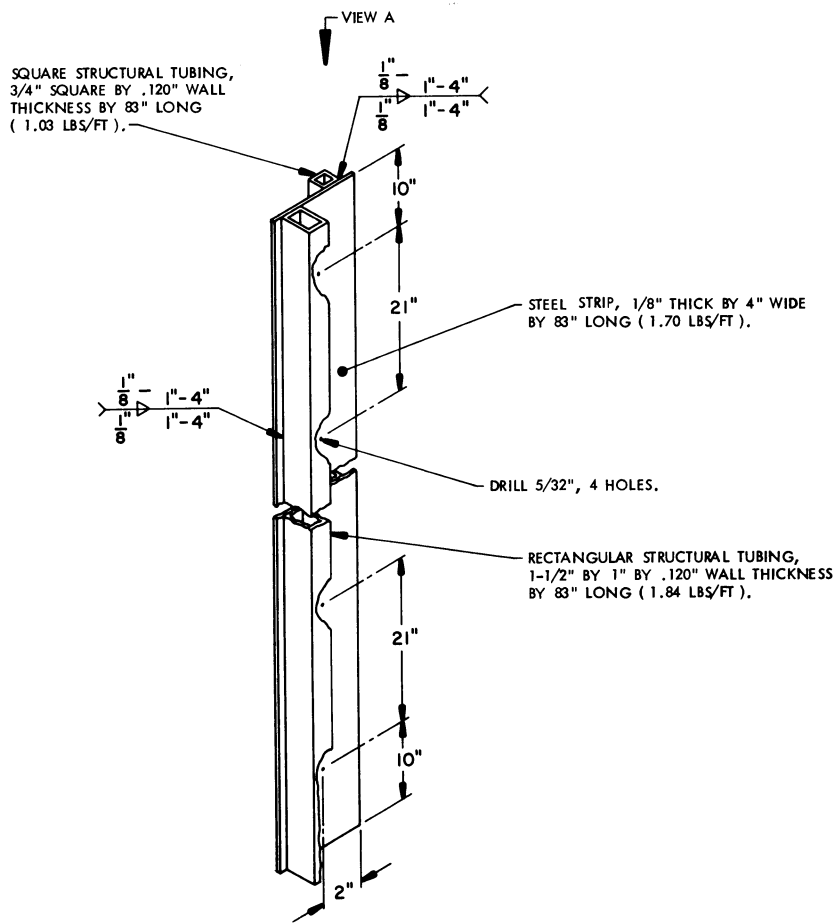

DOOR POST VERTICAL RETAINER