

APPROVED BY U.S. COAST GUARD <i>R.H. Likon</i>	APPROVED BY BUREAU OF EXPLOSIVES <i>M.B. Miller</i> SUPERVISOR, MILITARY & INTERMODAL SERVICES
DATE <i>5/19/80</i>	DATE <i>6/30/80</i>

LOADING AND BRACING WITH WOODEN DUNNAGE IN COMMERCIAL CONTAINERS OF PALLETIZED UNITS OF 25.4MM DECOY CARTRIDGES (24-BOX PALLET UNIT) (WOODEN BOX)

THE DEPICTED WOODEN DUNNAGE METHOD CAN BE APPLIED TO ANY COMMERCIAL INTERMODAL 20-FOOT CONTAINER, ALTHOUGH THE DUNNAGE DIMENSIONS HAVE BEEN GIVEN FOR A 92" WIDE BY 95" HIGH (INSIDE DIMENSIONS) CONTAINER. ALTHOUGH THE LOAD AS SHOWN IS BASED ON AN 8'-6" HIGH CONTAINER, AN 8'-0" HIGH CONTAINER IS PREFERRED FOR SHIPPING THE DEPICTED LOAD. WHEN AN 8'-0" HIGH CONTAINER IS USED, THE HEIGHT OF SOME DUNNAGE ASSEMBLIES WILL HAVE TO BE LOWERED BY REMOVING SOME MATERIAL FROM THE TOP OR BOTTOM OF SOME OF THE VERTICAL PIECES.

LOADING AND BRACING SPECIFICATIONS AS DELINEATED HEREIN ARE ADEQUATE FOR SHIPMENTS TO BE MOVED BY ANY SURFACE MODE OF TRANSPORT (MOTOR, RAIL, AND WATER).

REQUIREMENTS CITED WITHIN THE BUREAU OF EXPLOSIVES PAMPHLET 6C APPLY WHEN THE SHIPMENT MOVES BY TRAILER/CONTAINER-ON-FLAT-CAR (T/COFC). SPECIAL T/COFC NOTES FOLLOW.

- A. A LOADED CONTAINER MUST BE ON A CHASSIS EQUIPPED WITH TWO BOGIE ASSEMBLIES WHEN BEING MOVED IN TOFC SERVICE.
- B. THE LOAD LIMIT OF A T/COFC RAIL CAR MUST NOT BE EXCEEDED, NOR WILL A CAR BE LOADED SO THAT THE TRUCK UNDER ONE END OF THE CAR CARRIES MORE THAN ONE-HALF OF THE LOAD LIMIT FOR THAT CAR.

DURING INTRASTATE AND/OR INTERSTATE MOVES BY MOTOR CARRIER, A PROPER CHASSIS/MODIFIED FLAT BED TRAILER MUST BE USED TO PRECLUDE VIOLATION OF ONE OR MORE "WEIGHT LAWS" APPLICABLE TO THE STATE OR STATES INVOLVED.

REVISIONS				DRAFTSMAN <i>R.H. Likon</i>	PROJ ENG <i>WRE/JES</i>
				CHECKER <i>RSH</i>	LOG ENGINE OFFICE <i>WRE/JES</i>
APPROVED, U. S. ARMY ARMAMENT MATERIEL READINESS COMMAND <i>Darrel C. Fetter</i>					
APPROVED BY ORDER OF COMMANDING GENERAL, U. S. ARMY MATERIEL DEVELOPMENT AND READINESS COMMAND (DARCOM) <i>John L. Boyd</i> U. S. ARMY DEFENSE AMMUNITION CENTER AND SCHOOL					
U. S. ARMY DARCOM DRAWING					
JUNE 1980					
DEF AMMO CEN & SCH DWG NO					
D-SARAC-4444					

DO NOT SCALE

INDICATES A PALLET UNIT. SEE THE "PALLET UNIT" DETAIL ON PAGE 8 FOR THE SPECIFIC UNIT CONFIGURATION AND OTHER PERTINENT DATA.

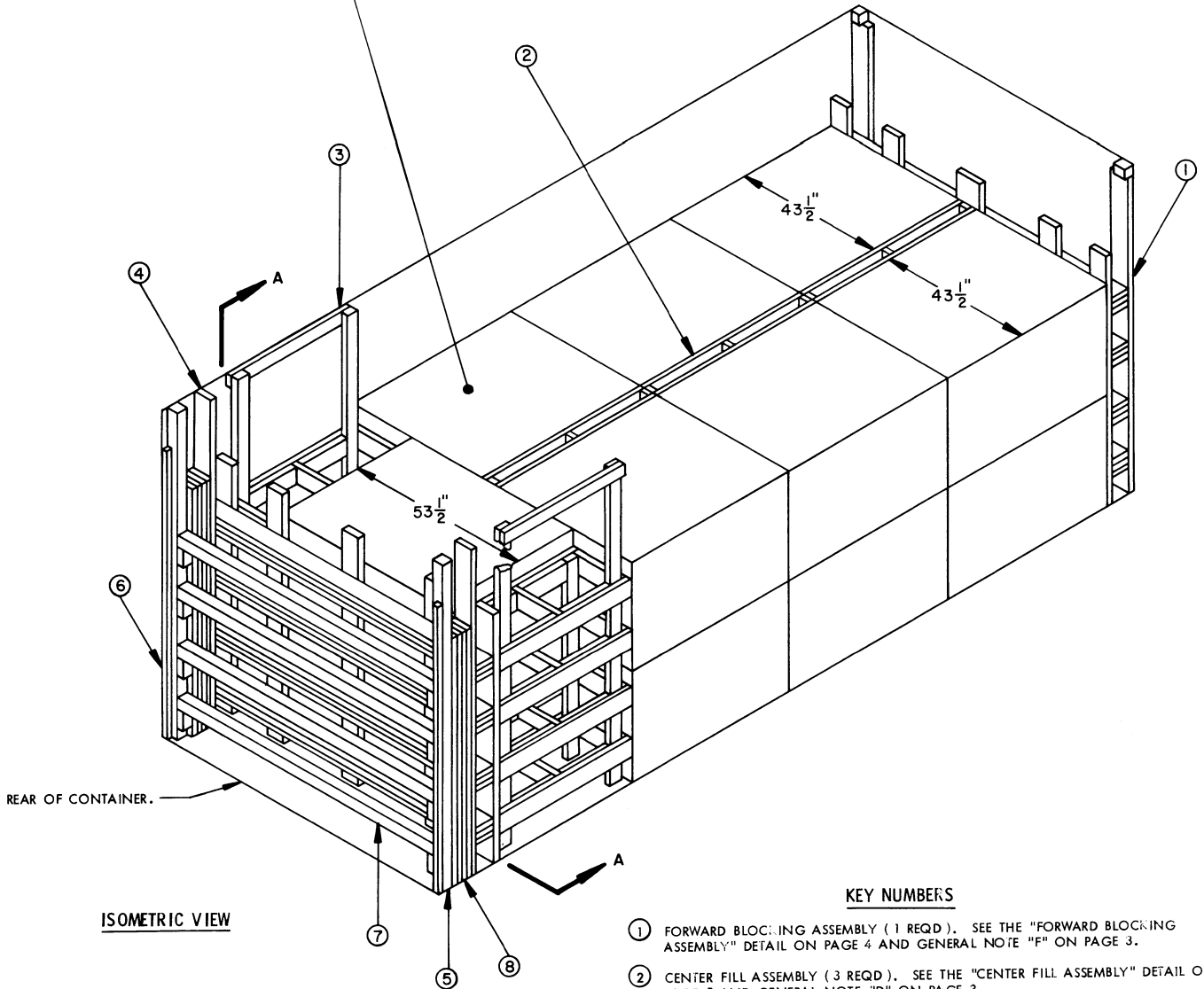

ISOMETRIC VIEW

REAR OF CONTAINER.

KEY NUMBERS

- ① FORWARD BLOCKING ASSEMBLY (1 REQD). SEE THE "FORWARD BLOCKING ASSEMBLY" DETAIL ON PAGE 4 AND GENERAL NOTE "F" ON PAGE 3.
- ② CENTER FILL ASSEMBLY (3 REQD). SEE THE "CENTER FILL ASSEMBLY" DETAIL ON PAGE 5 AND GENERAL NOTE "D" ON PAGE 3.
- ③ FILLER ASSEMBLY (2 REQD). SEE THE "FILLER ASSEMBLY" DETAIL ON PAGE 4.
- ④ REAR BLOCKING ASSEMBLY (1 REQD). SEE THE "REAR BLOCKING ASSEMBLY" DETAIL ON PAGE 5 AND GENERAL NOTE "F" ON PAGE 3.
- ⑤ DOOR POST VERTICAL (2 REQD). SEE THE "DOOR POST VERTICAL" DETAIL AND "DETAIL B" ON PAGE 7.
- ⑥ DOOR POST VERTICAL RETAINER (2 REQD). SEE THE "DOOR POST VERTICAL RETAINER" DETAILS ON PAGE 6 AND "DETAIL A" ON PAGE 7. NAIL THROUGH THE HOLES INTO THE DOOR POST VERTICAL WITH 3 NAILS.
- ⑦ DOOR SPANNER, 4" X 4" MATERIAL, CUT TO A LENGTH THAT WILL PROVIDE FOR A DRIVE FIT (REF: 7'-1-3/8") (4 REQD). TO NAIL ON THE 4" X 4" DOOR POST VERTICAL PIECES W/2-12d NAILS AT EACH END. SEE THE "BEVEL-CUT" DETAIL ON PAGE 7. AFTER INSTALLING THE BOTTOM AND TOP DOOR SPANNERS, THE FILL MATERIAL, PIECE MARKED ⑧, IS TO BE INSTALLED.
- ⑧ FILL MATERIAL, 6" WIDE BY 1/2" LONG MATERIAL (AS REQD). NAIL EACH PIECE TO THE REAR BLOCKING ASSEMBLY AND/OR LAMINATE TOGETHER W/7 NAILS OF A SUITABLE SIZE. (10d NAILS FOR 2" MATERIAL) **CAUTION:** DO NOT NAIL TO THE DOOR POST VERTICALS, PIECES MARKED ⑤.

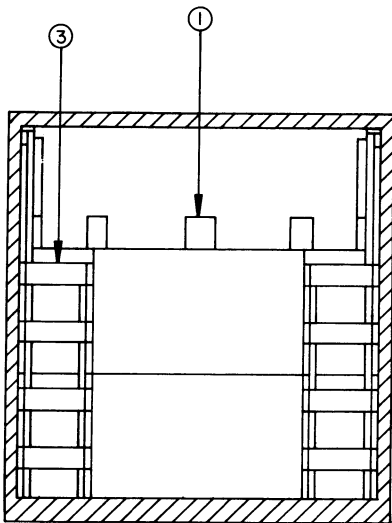

SECTION A-A

K. RECOMMENDED SEQUENTIAL LOADING PROCEDURES:

1. PREFABRICATE ONE FORWARD BLOCKING ASSEMBLY, THREE CENTER FILL ASSEMBLIES, TWO FILLER ASSEMBLIES, ONE REAR BLOCKING ASSEMBLY, AND NAIL A DOOR POST VERTICAL RETAINER TO EACH DOOR POST VERTICAL, ONE RIGHT HAND AND ONE LEFT HAND.
2. INSTALL FORWARD BLOCKING ASSEMBLY.
3. LOAD FOUR PALLET UNITS AND INSTALL ONE CENTER FILL ASSEMBLY.
4. REPEAT STEP 3.
5. REPEAT STEP 3.
6. LOAD REMAINING TWO PALLET UNITS AND INSTALL THE TWO FILLER ASSEMBLIES.
7. INSTALL REAR BLOCKING ASSEMBLY.
8. INSTALL THE TWO DOOR POST VERTICAL ASSEMBLIES (ONE RIGHT HAND AND ONE LEFT HAND).
9. INSTALL TWO DOOR SPANNER PIECES (ONE AT THE LOWEST POSITION AND ONE AT THE UPPERMOST POSITION).
10. INSTALL THE SOLID FILL TYPE LOAD BLOCKING MATERIAL.
11. INSTALL THE REMAINING TWO DOOR SPANNER PIECES.

- A. THIS DOCUMENT HAS BEEN PREPARED AND ISSUED IN ACCORDANCE WITH AR 740-1 AND AUGMENTS TM 743-200-1 (CHAPTER 5).
- B. THE SPECIFIED OUTLOADING PROCEDURE IS APPLICABLE TO A LOAD OF 24-BOX PALLET UNITS OF 25.4MM DECOY CARTRIDGES PACKED IN WOODEN BOXES. SUBSEQUENT REFERENCE TO PALLET UNIT MEANS THE PALLET UNIT WITH AMMUNITION ITEMS. SEE PAGE 8 FOR THE DETAIL OF THE PALLET UNIT. **CAUTION:** REGARDLESS OF THE QUANTITY OF UNITS TO BE SHIPPED, THE "MAXIMUM GROSS WEIGHT" OF 44,800 POUNDS MUST NOT BE EXCEEDED.
- C. THE LOAD AS SHOWN IS BASED ON A 4,700 POUND 20' LONG BY 8' WIDE BY 8'-6" HIGH INTERMODAL COMMERCIAL CONTAINER WITH INSIDE DIMENSIONS OF 19'-4" LONG BY 92" WIDE BY 95" HIGH. THE LOAD IS DESIGNED FOR TRAILER/CONTAINER-ON-FLAT CAR (T/COFC) SHIPMENT, HOWEVER, THE LOAD AS DESIGNED CAN ALSO BE MOVED BY OTHER SURFACE MODES OF TRANSPORT. **NOTICE:** OTHER CONTAINERS OF THE SAME DESIGN CONFIGURATION CAN BE USED.
- D. WHEN LOADING PALLET UNITS, THEY ARE TO BE POSITIONED SO AS TO ACHIEVE A TIGHT LOAD (TIGHT AGAINST THE FORWARD BLOCKING ASSEMBLY AND CONTAINER SIDE WALL). ALTHOUGH A TOTAL OF ONE AND ONE-HALF INCHES (1-1/2") OF UNBLOCKED SPACE ACROSS THE WIDTH OF A LOAD BAY IS PERMITTED, LATERAL VOIDS WITHIN THE LOAD ARE TO BE HELD TO A MINIMUM. EXCESSIVE SLACK CAN BE ELIMINATED FROM A LOAD BY LAMINATING ADDITIONAL PIECES OF APPROPRIATE THICKNESS TO THE HORIZONTAL PIECES ON ONE OR BOTH SIDES OF THE CENTER FILL ASSEMBLIES. NAIL EACH ADDITIONAL PIECE TO THE HORIZONTAL PIECE W/ APPROPRIATELY SIZED NAIL EVERY 12". ADDITIONALLY, THE NUMBER AND THICKNESS OF THE HORIZONTAL PIECES MAY BE ADJUSTED AS REQUIRED TO FACILITATE VARIANCE IN THE LENGTH OF THE PALLET UNIT.
- E. DUNNAGE LUMBER SPECIFIED IS OF A NOMINAL SIZE. FOR EXAMPLE, 1" X 6" MATERIAL IS ACTUALLY 3/4" THICK BY 5-1/2" WIDE AND 2" X 6" MATERIAL IS ACTUALLY 1-1/2" THICK BY 5-1/2" WIDE.
- F. A STAGGERED NAILING PATTERN WILL BE USED WHEREVER POSSIBLE WHEN NAILS ARE DRIVEN INTO JOINTS OF DUNNAGE ASSEMBLIES OR WHEN LAMINATING DUNNAGE. ADDITIONALLY, THE NAILING PATTERN FOR AN UPPER PIECE OF LAMINATED DUNNAGE WILL BE ADJUSTED AS REQUIRED SO THAT A NAIL FOR THAT PIECE WILL NOT BE DRIVEN THROUGH ONTO OR RIGHT BESIDE A NAIL IN A LOWER PIECE.
- G. IN SOME CONTAINERS, SUCH AS SOME ALL STEEL CONTAINERS, THERE IS A SLOT AT THE CORNERS OF THE FORWARD WALL. A PIECE OF DUNNAGE MATERIAL MUST BE LAMINATED TO THE BUFFER PIECES ON THE FORWARD BLOCKING ASSEMBLY TO PROVIDE A FLAT SURFACE FOR THE 2" X 6" BUFFER PIECES. A PIECE OF 2" X 4", 2" X 3", OR A SPECIAL WIDTH PIECE CUT-TO-FIT CAN BE USED. THIS FILL PIECE WILL BE NAILED WITH ONE APPROPRIATELY SIZED NAIL EVERY 12". THIS PIECE IS NOT REQUIRED WHEN THE FRONT WALL OF THE CONTAINER IS SMOOTH AND FLAT.
- H. **CAUTION:** DO NOT NAIL DUNNAGE MATERIAL TO THE CONTAINER WALLS OR FLOOR. ALL NAILING WILL BE WITHIN THE DUNNAGE.
- J. PORTIONS OF THE CONTAINERS DEPICTED WITHIN THIS DRAWING, SUCH AS ONE OF THE SIDE WALLS, HAVE NOT BEEN SHOWN IN THE LOAD VIEWS FOR CLARITY PURPOSES.

(CONTINUED AT LEFT)

BILL OF MATERIAL		
LUMBER	LINEAR FEET	BOARD FEET
1" X 6"	107	54
2" X 4"	124	83
2" X 6"	449	449
2" X 8"	6	8
4" X 4"	45	60
NAILS	NO. REQD	POUNDS
6d (2")	144	1
10d (3")	770	12
12d (3-7/4")	16	1/4
DOOR POST VERTICAL RETAINER --- 2 REQD ----- 64 LBS		

MATERIAL SPECIFICATIONS

- LUMBER ----- : TM 743-200-1 (DUNNAGE LUMBER) AND FED SPEC MM-L-751.
- NAILS ----- : FED SPEC FF-N-105; COMMON.
- STEEL, STRUCTURAL ----- : FED SPEC QQ-5-741; SQUARE STRUCTURAL TUBING AND HOT-ROLLED STRIP.

LOAD AS SHOWN

ITEM	QUANTITY	WEIGHT (APPROX)
PALLET UNIT -----	14 -----	23,730 LBS
DUNNAGE -----		1,386 LBS
CONTAINER -----		4,700 LBS
TOTAL WEIGHT -----		29,816 LBS

SEE GENERAL NOTE "G" ON PAGE 3.

BEAM ASSEMBLY, 2" X 6" BY INSIDE CONTAINER WIDTH MINUS 1" (REF: 7'-7") (TRIPLED) (4 REQD). LAMINATE THE SECOND PIECE TO THE FIRST PIECE W/11-10d NAILS. LAMINATE THE THIRD PIECE TO THE SECOND PIECE IN A LIKE MANNER.

LOAD BEARING PIECE, 2" X 8" X 72" (1 REQD). NAIL TO THE BEAM ASSEMBLIES W/3-10d NAILS AT EACH JOINT.

BUFFER PIECE, 2" X 6" X INSIDE CONTAINER HEIGHT MINUS 1/2" (REF: 7'-7-1/2") (2 REQD). NAIL TO THE BEAM ASSEMBLIES W/2-10d NAILS AT EACH JOINT.

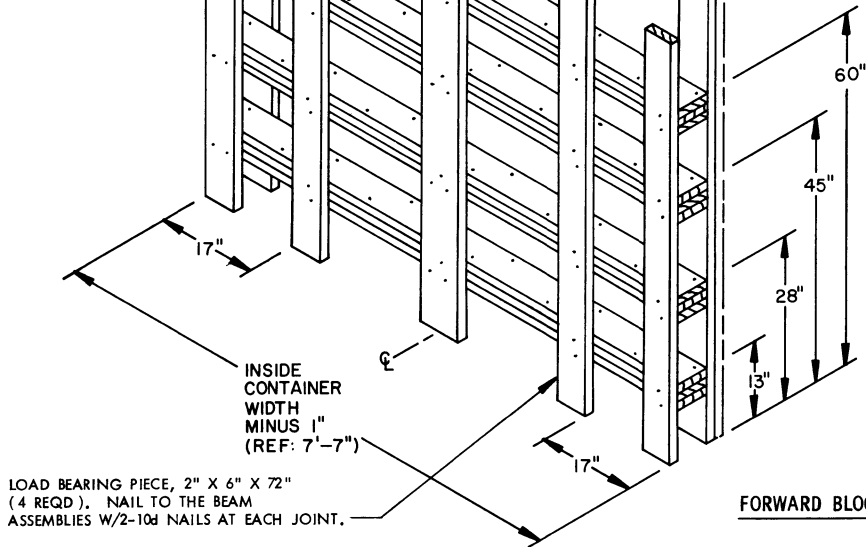

FORWARD BLOCKING ASSEMBLY

SUPPORT PIECE, 2" X 6" X 16-1/4" (4 REQD).

TIE PIECE, 2" X 4" X 40-1/2" (1 REQD). NAIL TO THE VERTICAL PIECES W/3-10d NAILS AT EACH END.

FILL PIECE, 2" X 6" X 16" (16 REQD). NAIL TO THE LONGITUDINAL PIECE W/4-10d NAILS.

LATERAL PIECE, 2" X 6" X 16-1/4" (8 REQD). NAIL TO THE VERTICAL PIECES W/3-10d NAILS AT EACH END.

VERTICAL PIECE, 2" X 4" X 60" (2 REQD).

INDICATES CONTAINER SIDE OF FILLER ASSEMBLY.

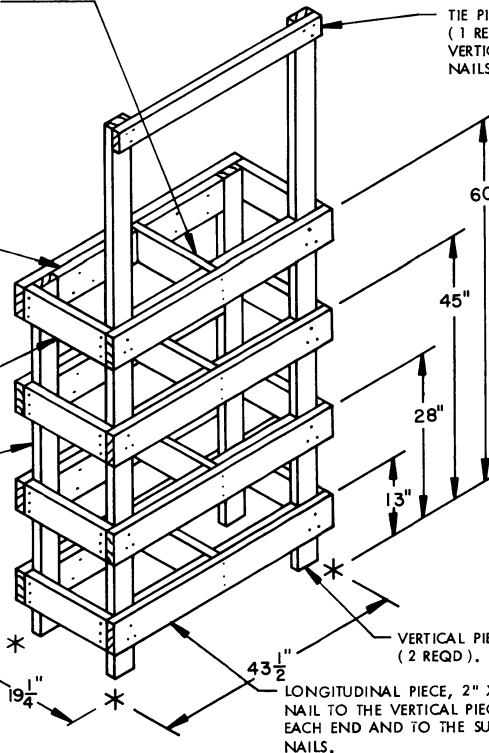

FILLER ASSEMBLY

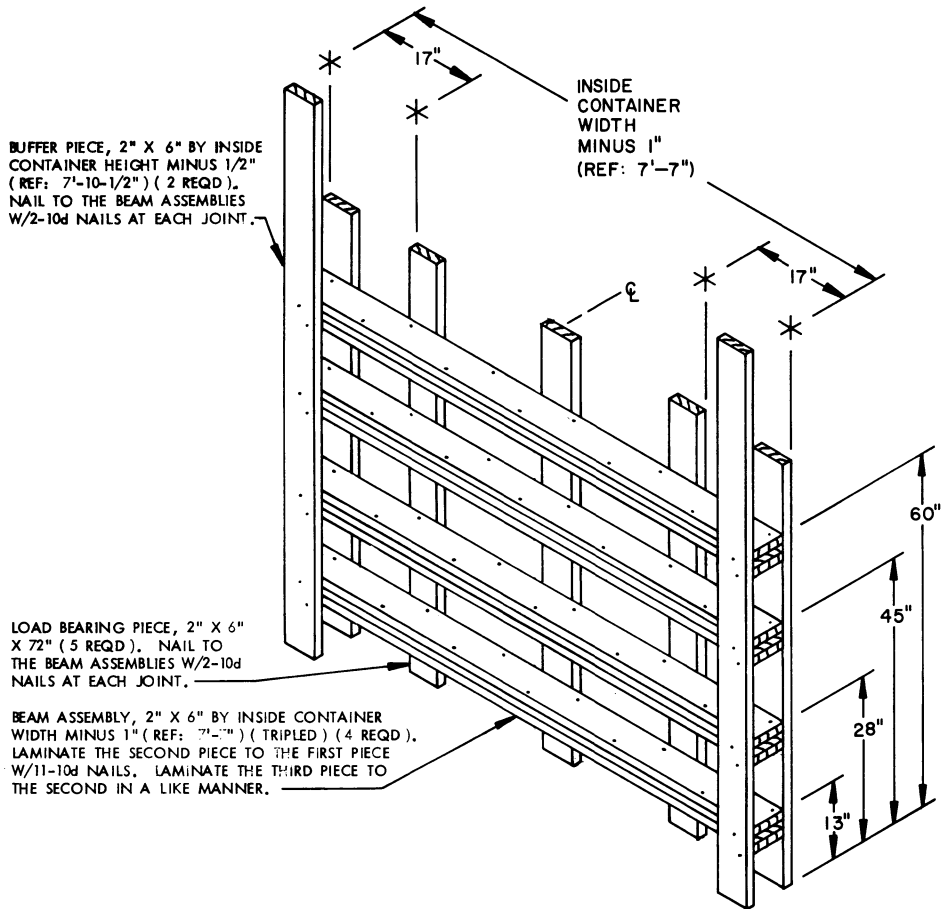

REAR BLOCKING ASSEMBLY

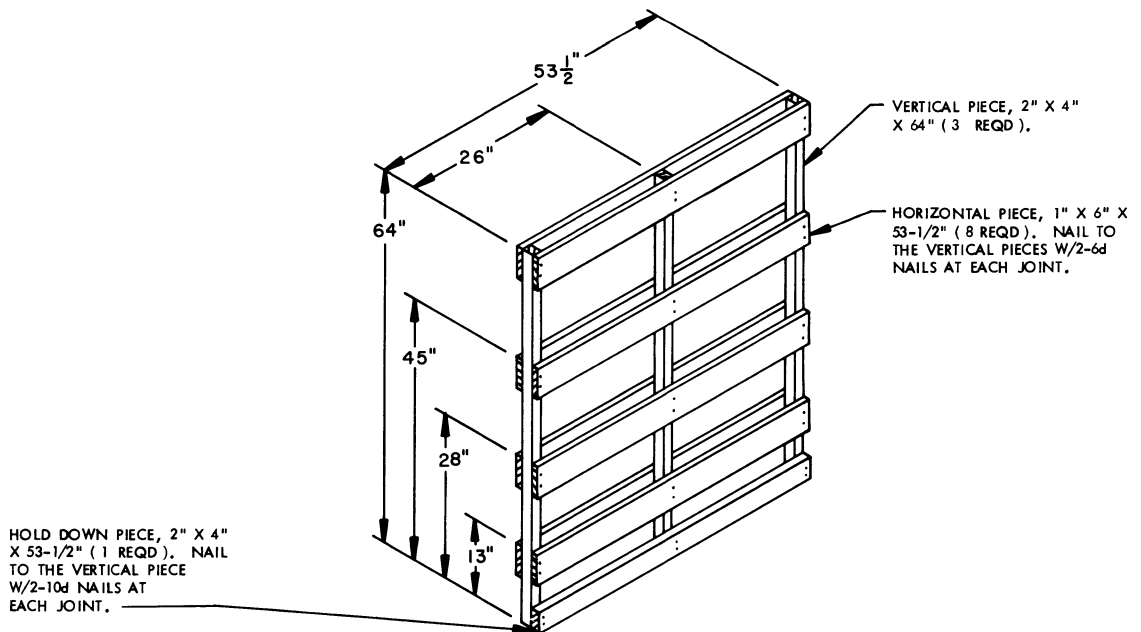

CENTER FILL ASSEMBLY

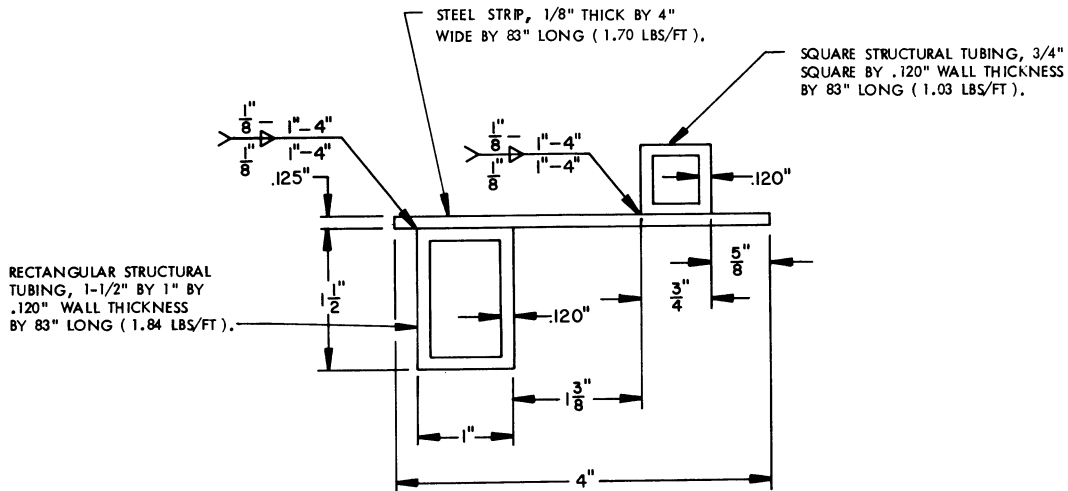

VIEW A

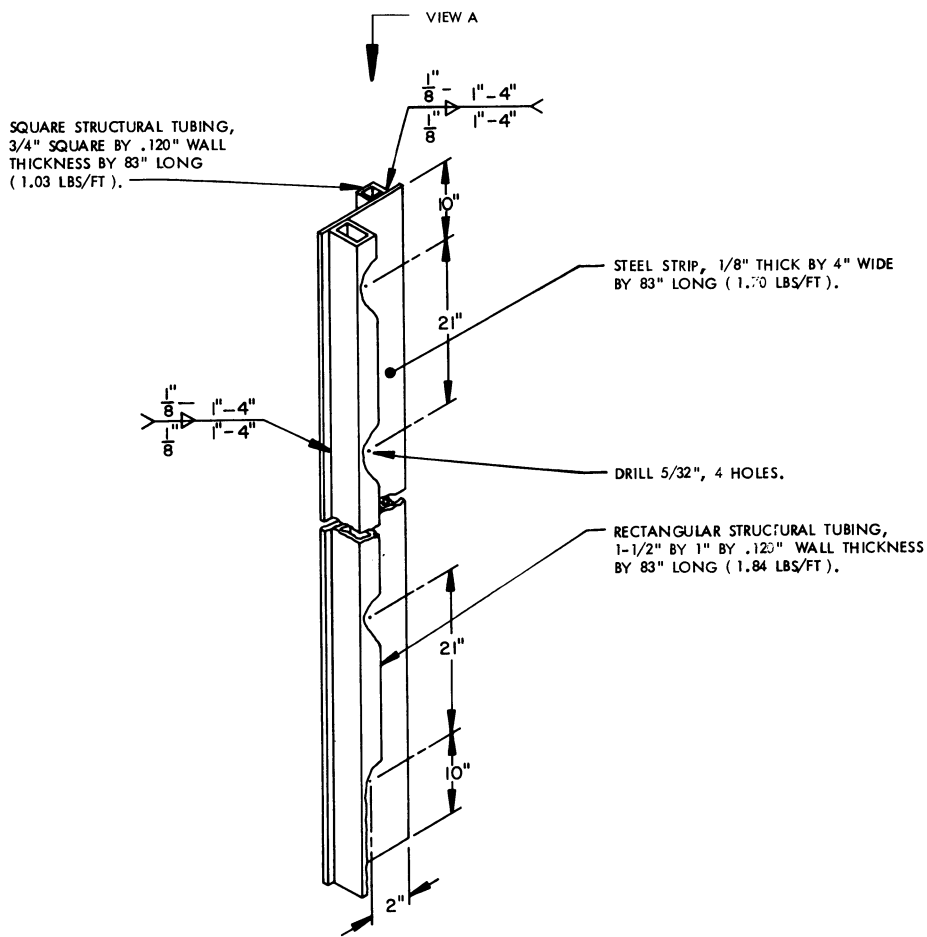

DOOR POST VERTICAL RETAINER

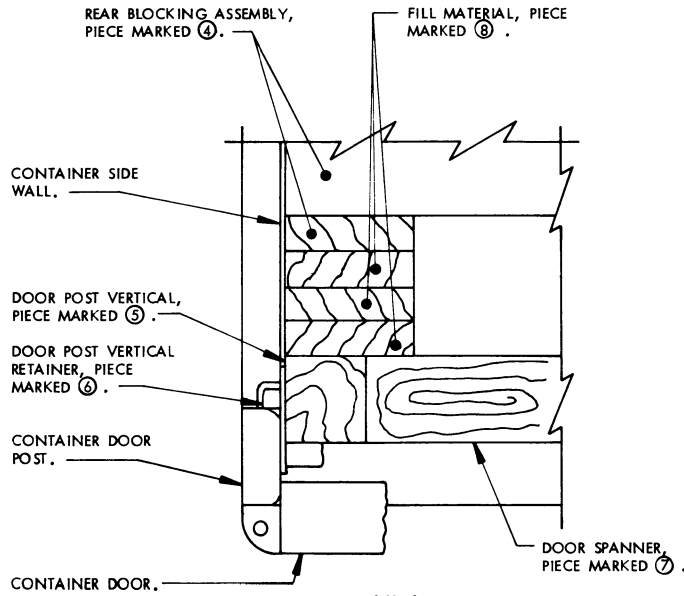

DETAIL A

A PARTIAL PLAN VIEW OF THE LEFT REAR PORTION OF THE CONTAINER IS SHOWN DEPICTING THE PROPER POSITION OF THE DOOR POST VERTICAL AND ADJACENT DUNNAGE PIECES.

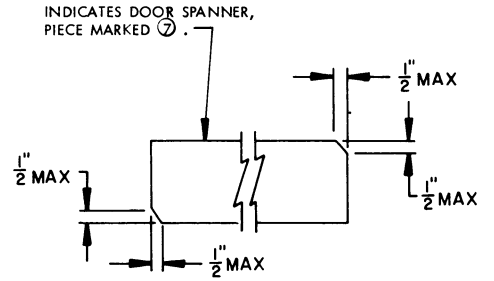

BEVEL - CUT

IF DESIRED, EACH END OF A DOOR SPANNER PIECE MAY BE BEVEL-CUT AS SHOWN ABOVE TO FACILITATE THE ACHIEVEMENT OF A TIGHT DOOR-POST-TO-DOOR-POST FIT.

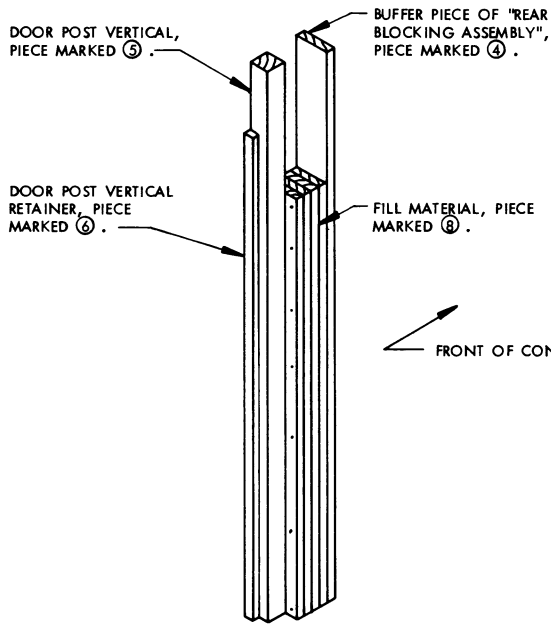

DETAIL B

DOOR SPANNERS HAVE BEEN OMITTED FOR CLARITY PURPOSES.

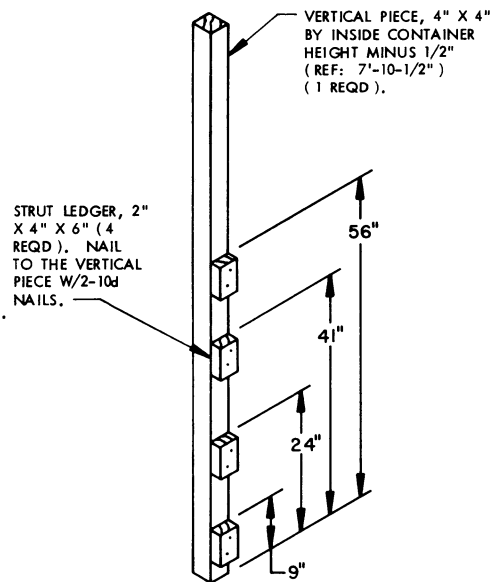

DOOR POST VERTICAL

THE STRUT LEDGERS CAN ONLY BE PRE-NAILED TO THE DOOR POST VERTICAL ON ONE SIDE OF THE CONTAINER. THE STRUT LEDGERS ON THE OTHER SIDE ARE TO BE NAILED AFTER A LOWER DOOR SPANNER IS INSTALLED.

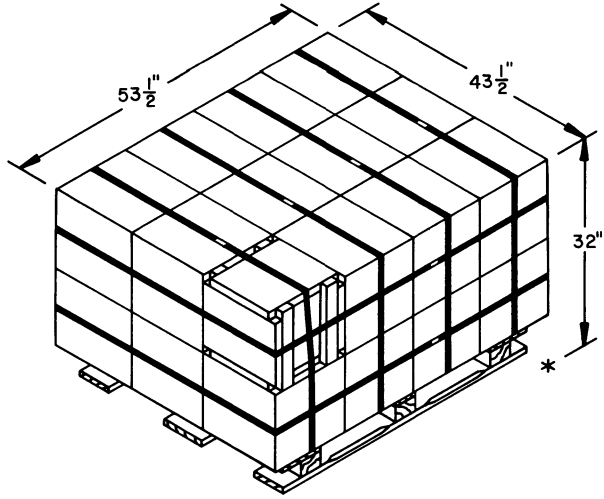

PALLET UNIT

UNIT WEIGHT ----- 1,695 LBS (APPROX).

CUBE ----- 43.1 CUBIC FEET.