

APPROVED BY U.S. COAST GUARD <i>F. H. Gibson</i>	APPROVED BY BUREAU OF EXPLOSIVES <i>M. R. Miller</i> SUPERVISOR, MILITARY & INTERMODAL SERVICES
DATE <i>11/29/79</i>	DATE <i>12-17-79</i>

# LOADING AND BRACING WITH WOODEN DUNNAGE IN COMMERCIAL CONTAINERS OF PALLETIZED UNITS OF 81MM BOXED AMMUNITION (40-BOX PALLET UNIT) (WOODEN BOX)

THE DEPICTED WOODEN DUNNAGE METHOD CAN BE APPLIED TO ANY COMMERCIAL INTERMODAL 20-FOOT CONTAINER, ALTHOUGH THE DUNNAGE DIMENSIONS HAVE BEEN GIVEN FOR A 92" WIDE BY 95" HIGH (INSIDE DIMENSIONS) CONTAINER. ALTHOUGH THE LOAD AS SHOWN IS BASED ON AN 8'-6" HIGH CONTAINER, AN 8'-0" HIGH CONTAINER IS PREFERRED FOR SHIPPING THE DEPICTED LOAD. WHEN AN 8'-0" HIGH CONTAINER IS USED, THE HEIGHT OF SOME DUNNAGE ASSEMBLIES WILL HAVE TO BE LOWERED BY REMOVING SOME MATERIAL FROM THE TOP OR BOTTOM OF SOME OF THE VERTICAL PIECES.

LOADING AND BRACING SPECIFICATIONS AS DELINEATED HEREIN ARE ADEQUATE FOR SHIPMENTS TO BE MOVED BY ANY SURFACE MODE OF TRANSPORT (MOTOR, RAIL, AND WATER).

REQUIREMENTS CITED WITHIN THE BUREAU OF EXPLOSIVES PAMPHLET 6C APPLY WHEN THE SHIPMENT MOVES BY TRAILER/CONTAINER-ON-FLAT-CAR (T/COFC). SPECIAL T/COFC NOTES FOLLOW.

- A. A LOADED CONTAINER MUST BE ON A CHASSIS EQUIPPED WITH TWO BOGIE ASSEMBLIES WHEN BEING MOVED IN TOFC SERVICE.
- B. THE LOAD LIMIT OF A T/COFC RAIL CAR MUST NOT BE EXCEEDED, NOR WILL A CAR BE LOADED SO THAT THE TRUCK UNDER ONE END OF THE CAR CARRIES MORE THAN ONE-HALF OF THE LOAD LIMIT FOR THAT CAR.

DURING INTRASTATE AND/OR INTERSTATE MOVES BY MOTOR CARRIER, A PROPER CHASSIS/MODIFIED FLAT BED TRAILER MUST BE USED TO PRECLUDE VIOLATION OF ONE OR MORE "WEIGHT LAWS" APPLICABLE TO THE STATE OR STATES INVOLVED.

REVISIONS				DRAFTSMAN <i>P.B.</i>	PROJ ENG <i>WRE/216</i>
				CHECKER <i>RSH</i>	LOG ENGAG OFFICE <i>W7 Emute</i>
				APPROVED, U. S. ARMY ARMAMENT MATERIEL READINESS COMMAND <i>Edward ...</i>	
				APPROVED BY ORDER OF COMMANDING GENERAL, U. S. ARMY MATERIEL DEVELOPMENT AND READINESS COMMAND (DARCOM) <i>John L. Beard</i> U. S. ARMY DEFENSE AMMUNITION CENTER AND SCHOOL	
				U. S. ARMY DARCOM DRAWING	
				DECEMBER 1979	
				DEF AMMO CEN & SCH DWG NO.	
				<b>D-SARAC-4430</b>	

**DO NOT SCALE**

INDICATES A PALLET UNIT. SEE THE "PALLET UNIT" DETAIL ON PAGE 5 FOR THE SPECIFIC UNIT CONFIGURATION AND OTHER PERTINENT DATA.

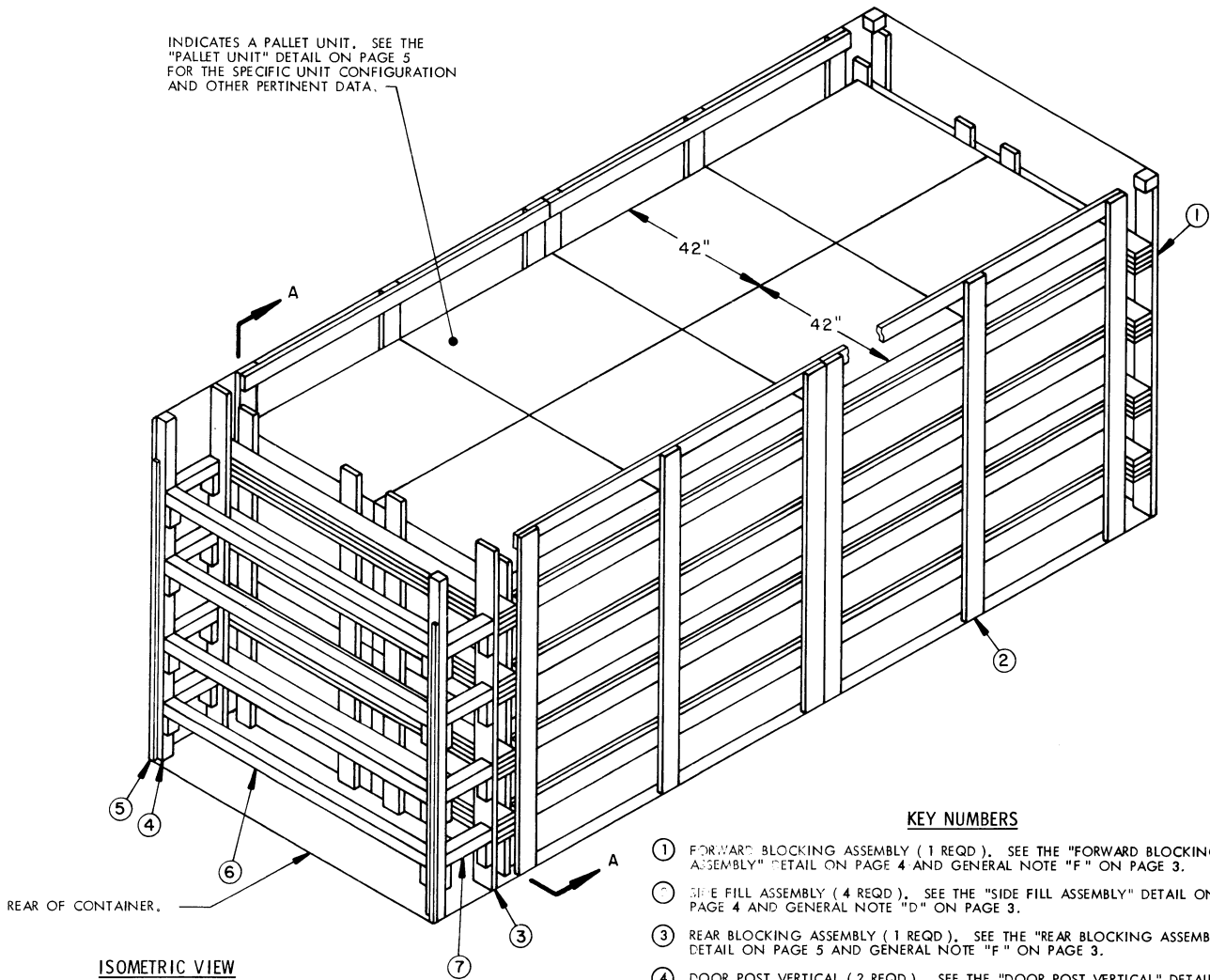

ISOMETRIC VIEW

**KEY NUMBERS**

- ① FORWARD BLOCKING ASSEMBLY ( 1 REQD ). SEE THE "FORWARD BLOCKING ASSEMBLY" DETAIL ON PAGE 4 AND GENERAL NOTE "F" ON PAGE 3.
- ② SIDE FILL ASSEMBLY ( 4 REQD ). SEE THE "SIDE FILL ASSEMBLY" DETAIL ON PAGE 4 AND GENERAL NOTE "D" ON PAGE 3.
- ③ REAR BLOCKING ASSEMBLY ( 1 REQD ). SEE THE "REAR BLOCKING ASSEMBLY" DETAIL ON PAGE 5 AND GENERAL NOTE "F" ON PAGE 3.
- ④ DOOR POST VERTICAL ( 2 REQD ). SEE THE "DOOR POST VERTICAL" DETAIL AND "DETAIL A" ON PAGE 6.
- ⑤ DOOR POST VERTICAL RETAINER ( 2 REQD ). SEE THE "DOOR POST VERTICAL RETAINER" DETAILS ON PAGE 7. NAIL THROUGH THE HOLES INTO THE DOOR POST VERTICAL W/4-10d NAILS.
- ⑥ DOOR SPANNER, 4" X 4" MATERIAL, CUT TO A LENGTH THAT WILL PROVIDE FOR A DRIVE FIT BETWEEN DOOR POST VERTICALS ( REF: 7'-1-3/8" ) ( 4 REQD ). TOENAIL TO THE DOOR POST VERTICALS W/2-12d NAILS AT EACH END. SEE THE "BEVEL-CUT" DETAIL ON PAGE 6. AFTER INSTALLING THE BOTTOM AND THE TOP DOOR SPANNERS, THE STRUTS, PIECES MARKED ⑦, ARE TO BE INSTALLED.
- ⑦ STRUT, 4" X 4" BY CUT-TO-FIT ( 8 REQD ). TOENAIL TO THE BUFFER PIECES OF THE REAR BLOCKING ASSEMBLY AND DOOR POST VERTICAL W/2-12d NAILS AT EACH END. SEE THE "BEVEL-CUT" DETAIL ON PAGE 6.

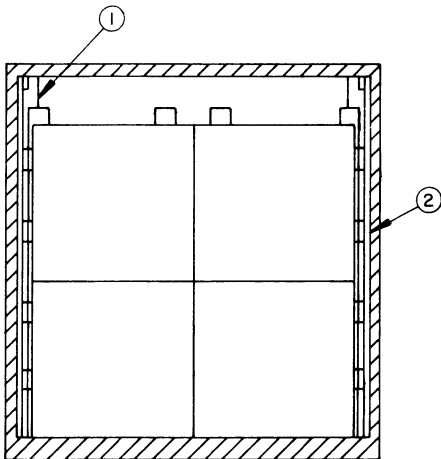

SECTION A - A

( GENERAL NOTES CONTINUED )

L. RECOMMENDED SEQUENTIAL LOADING PROCEDURES:

1. PREFABRICATE ONE FORWARD BLOCKING ASSEMBLY, FOUR SIDE FILL ASSEMBLIES, ONE REAR BLOCKING ASSEMBLY, AND NAIL A DOOR POST VERTICAL RETAINER TO EACH DOOR POST VERTICAL, ONE RIGHT HAND AND ONE LEFT HAND.
2. INSTALL FORWARD BLOCKING ASSEMBLY.
3. INSTALL ONE SIDE FILL ASSEMBLY AND LOAD TWO PALLET UNITS.
4. REPEAT STEP 3.
5. LOAD FOUR PALLET UNITS.
6. REPEAT STEP 3.
7. REPEAT STEP 3.
8. REPEAT STEP 5.
9. INSTALL REAR BLOCKING ASSEMBLY.
10. INSTALL THE TWO DOOR POST VERTICAL ASSEMBLIES ( ONE RIGHT HAND AND ONE LEFT HAND ).
11. INSTALL TWO DOOR SPANNER PIECES ( ONE AT THE LOWEST POSITION AND ONE AT THE UPPERMOST POSITION ).
12. INSTALL THE STRUTS BETWEEN THE REAR BLOCKING ASSEMBLY AND THE DOOR POST VERTICALS.
13. INSTALL THE REMAINING TWO DOOR SPANNER PIECES.

GENERAL NOTES

- A. THIS DOCUMENT HAS BEEN PREPARED AND ISSUED IN ACCORDANCE WITH AR 740-1 AND AUGMENTS TM 743-200-1 ( CHAPTER 5 ).
- B. THE SPECIFIED OUTLOADING PROCEDURE IS APPLICABLE TO A LOAD OF 40-BOX PALLET UNITS OF 81MM AMMUNITION PACKED IN WOODEN BOXES. SUBSEQUENT REFERENCE TO PALLET UNIT MEANS THE PALLET UNIT WITH AMMUNITION ITEMS. SEE PAGE 5 FOR THE DETAIL OF THE PALLET UNIT. CAUTION: REGARDLESS OF THE QUANTITY OF UNITS TO BE SHIPPED, THE "MAXIMUM GROSS WEIGHT" OF 44,800 POUNDS MUST NOT BE EXCEEDED.
- C. THE LOAD AS SHOWN IS BASED ON A 4,700 POUND 20' LONG BY 8' WIDE BY 8'-6" HIGH INTERMODAL COMMERCIAL CONTAINER WITH INSIDE DIMENSIONS OF 19'-4" LONG BY 92" WIDE BY 95" HIGH. THE LOAD IS DESIGNED FOR TRAILER/CONTAINER-ON-FLAT-CAR ( T/COFC ) SHIPMENT, HOWEVER, THE LOAD AS DESIGNED CAN ALSO BE MOVED BY OTHER SURFACE MODES OF TRANSPORT. NOTICE: OTHER CONTAINERS OF THE SAME DESIGN CONFIGURATION CAN BE USED.
- D. WHEN LOADING PALLET UNITS, THEY ARE TO BE POSITIONED SO AS TO ACHIEVE A TIGHT LOAD ( TIGHT AGAINST THE FORWARD AND SIDE DUNNAGE ASSEMBLIES ). ALTHOUGH A TOTAL OF ONE AND ONE-HALF INCHES ( 1-1/2" ) OF UNBLOCKED SPACE ACROSS THE WIDTH OF A LOAD BAY IS PERMITTED, LATERAL VOIDS WITHIN THE LOAD ARE TO BE HELD TO A MINIMUM. EXCESSIVE SLACK CAN BE ELIMINATED FROM A LOAD BY LAMINATING ADDITIONAL PIECES OF APPROPRIATE THICKNESS TO THE BEARING PIECES ON THE SIDE FILL ASSEMBLIES ON ONE OR BOTH SIDES OF THE CONTAINER. NAIL EACH ADDITIONAL PIECE TO THE BEARING PIECE W/1 APPROPRIATELY SIZED NAIL EVERY 12". ADDITIONALLY, THE NUMBER AND THICKNESS OF THE BEARING AND SPACER PIECES MAY BE ADJUSTED AS REQUIRED TO FACILITATE VARIANCE IN THE LENGTH OF THE PALLET UNIT.
- E. DUNNAGE LUMBER SPECIFIED IS OF A NOMINAL SIZE. FOR EXAMPLE, 1" X 6" MATERIAL IS ACTUALLY 3/4" THICK BY 5-1/2" WIDE AND 2" X 6" MATERIAL IS ACTUALLY 1-1/2" THICK BY 5-1/2" WIDE.
- F. A STAGGERED NAILING PATTERN WILL BE USED WHEREVER POSSIBLE WHEN NAILS ARE DRIVEN INTO JOINTS OF DUNNAGE ASSEMBLIES OR WHEN LAMINATING DUNNAGE. ADDITIONALLY, THE NAILING PATTERN FOR AN UPPER PIECE OF LAMINATED DUNNAGE WILL BE ADJUSTED AS REQUIRED SO THAT A NAIL FOR THAT PIECE WILL NOT BE DRIVEN THROUGH ONTO OR RIGHT BESIDE A NAIL IN A LOWER PIECE.
- G. IN SOME CONTAINERS, SUCH AS SOME ALL STEEL CONTAINERS, THERE IS A SLOT AT THE CORNERS OF THE FORWARD WALL. A PIECE OF DUNNAGE MATERIAL MUST BE LAMINATED TO THE BUFFER PIECES ON THE FORWARD BLOCKING ASSEMBLY TO PROVIDE A FLAT SURFACE FOR THE 2" X 6" BUFFER PIECES. A PIECE OF 2" X 4", 2" X 3", OR A SPECIAL WIDTH PIECE CUT-TO-FIT CAN BE USED. THIS FILL PIECE WILL BE NAILED WITH ONE APPROPRIATELY SIZED NAIL EVERY 12". THIS PIECE IS NOT REQUIRED WHEN THE FRONT WALL OF THE CONTAINER IS SMOOTH AND FLAT.
- H. CAUTION: DO NOT NAIL DUNNAGE MATERIAL TO THE CONTAINER WALLS OR FLOOR. ALL NAILING WILL BE WITHIN THE DUNNAGE.
- I. PORTIONS OF THE CONTAINERS DEPICTED WITHIN THIS DRAWING, SUCH AS ONE OF THE SIDE WALLS, HAVE NOT BEEN SHOWN IN THE LOAD VIEWS FOR CLARITY PURPOSES.
- K. TO MAKE LOADING EASIER, TO HELP ACHIEVE A TIGHT LOAD ACROSS A CONTAINER AND TO PREVENT UNACCEPTABLE DAMAGE TO LADING UNITS WHEN LOADING A CONTAINER, A SLIP-SHEET CAN BE USED EFFECTIVELY AS A "SHOE-HORN" TYPE DEVICE. THE SLIP-SHEET WILL PROVIDE A SMOOTH SURFACE THAT WILL PREVENT UNIT STRAPS AND/OR BOXES FROM INTERLOCKING OR CATCHING ON OTHER PROJECTIONS WHEN LATERALLY ADJACENT LADING UNITS ARE BEING LOADED. A SLIP-SHEET WILL BE USED AFTER ONE-HALF OF A STACK IS LOADED WITH ONE OF ITS SIDES IN TIGHT CONTACT AT ONE SIDE OF THE CONTAINER. THE SLIP-SHEET IS TO BE PLACED AGAINST THE OTHER SIDE OF THE HALF-STACK BEFORE THE LAST HALF OF THE STACK IS LOADED. AFTER A STACK IS COMPLETED, THE SLIP-SHEET IS TO BE REMOVED FOR SUBSEQUENT USE WITH THE NEXT STACK. A SLIP-SHEET OF SUITABLE SIZE CAN BE MADE FROM A SHEET OF 1/8" TEMPERED HARDBOARD ( MASONITE ) OR FROM A SHEET OF ANY OTHER MATERIAL THAT WILL SATISFY THE REQUIREMENT.

BILL OF MATERIAL		
LUMBER	LINEAR FEET	BOARD FEET
1" X 6"	130	65
2" X 4"	45	30
2" X 6"	555	555
4" X 4"	55	74
NAILS	NO. REQD	POUNDS
6d ( 2" )	144	1
10d ( 3" )	644	10
12d ( 3-1/4" )	48	1
DOOR POST VERTICAL RETAINER --- 2 REQD ----- 64 LBS		

MATERIAL SPECIFICATIONS

- LUMBER ----- : TM-743-200-1 ( DUNNAGE LUMBER ) AND FED SPEC MM-L-751.
- NAILS ----- : FED SPEC FF-N-105; COMMON.
- STEEL, STRUCTURAL ----- : FED SPEC QQ-5-741; SQUARE STRUCTURAL TUBING AND ROLLED PLATE.

( CONTINUED AT LEFT )

LOAD AS SHOWN

ITEM	QUANTITY	WEIGHT ( APPROX )
PALLET UNIT -----	16 -----	33,408 LBS
DUNNAGE -----		1,524 LBS
CONTAINER -----		4,700 LBS
TOTAL WEIGHT -----		39,632 LBS

BUFFER PIECE, 2" X 6" BY INSIDE CONTAINER HEIGHT MINUS 1/2" ( REF: 7'-7-1/2" ) ( 2 REQD ), NAIL TO THE BEAM ASSEMBLIES W/3-10d NAILS AT EACH JOINT.

BEAM ASS'Y., 2" X 6" BY INSIDE CONTAINER WIDTH MINUS 1" ( REF: 7'-7" ) ( QUADRUPLED ) ( 4 REQD ), LAMINATE THE SECOND PIECE TO THE FIRST PIECE W/11-10d NAILS. LAMINATE EACH ADDITIONAL PIECE IN A LIKE MANNER.

LOAD BEARING PIECE, 2" X 6" X 7'-3" ( 4 REQD ), NAIL TO THE BEAM ASSEMBLIES W/3-10d NAILS AT EACH JOINT.

SEE GENERAL NOTE "G" ON PAGE 3.

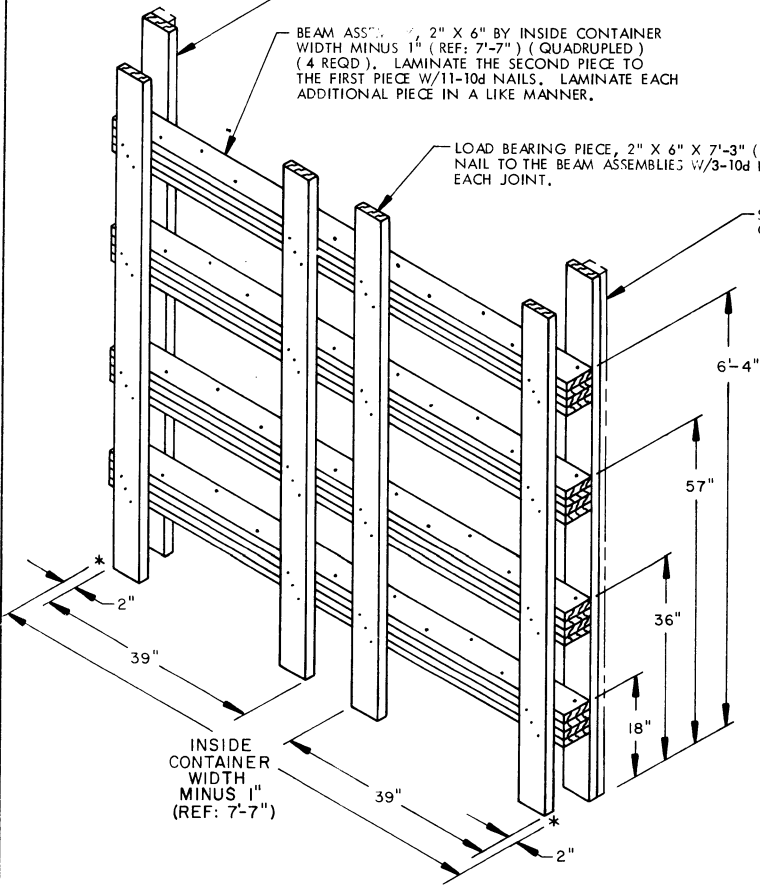

TIE PIECE, 2" X 4" X 8'-1" ( 1 REQD ), NAIL TO THE VERTICAL PIECES W/3-10d NAILS AT EACH JOINT.

**FORWARD BLOCKING ASSEMBLY**

BEARING PIECE, 1" X 6" X 8'-1" ( 4 REQD ), NAIL TO THE SPACER PIECE W/1-6d NAIL EVERY 12".

INSIDE CONTAINER HEIGHT MINUS 1" ( REF: 7'-10" )

VERTICAL PIECE, 2" X 6" BY INSIDE CONTAINER HEIGHT MINUS 1" ( REF: 7'-10" ) ( 3 REQD ).

SPACER PIECE, 2" X 6" X 8'-1" ( 4 REQD ), NAIL TO THE VERTICAL PIECES W/3-10d NAILS AT EACH JOINT.

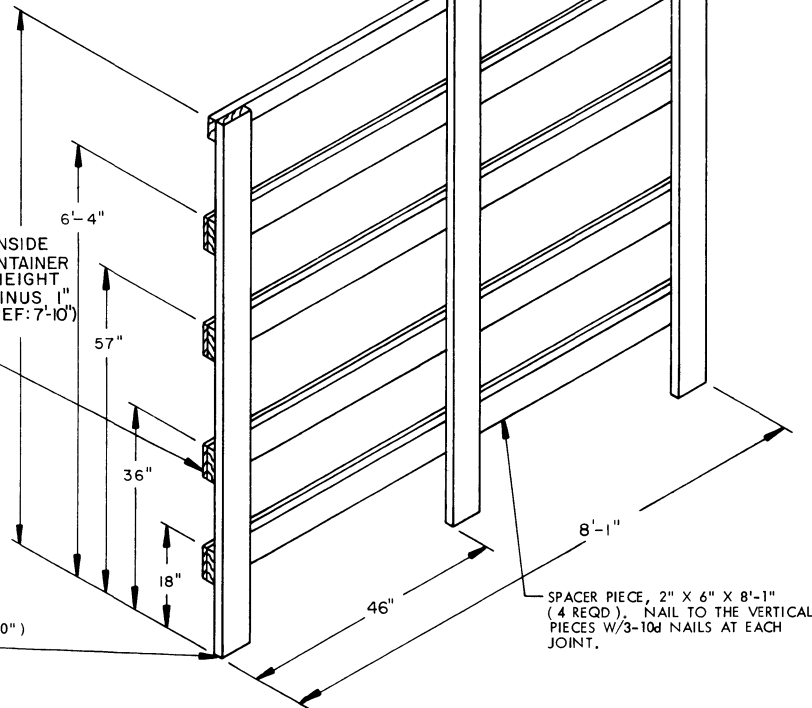

**SIDE FILL ASSEMBLY**

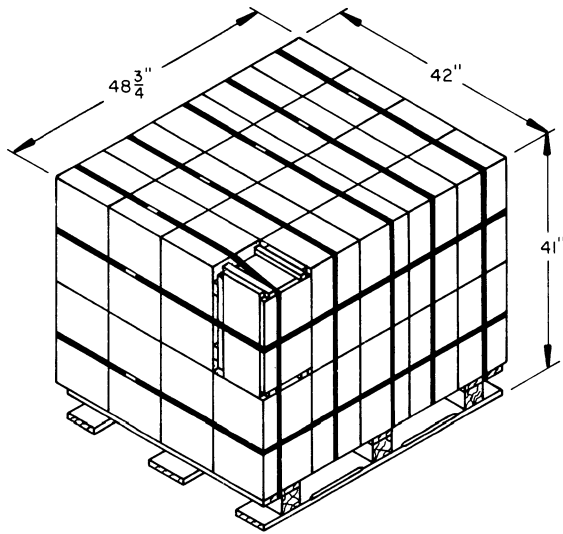

**PALLET UNIT**

UNIT WEIGHT ----- 2,088 LBS ( APPROX )  
 CUFE ----- 48.6 CUBIC FEET

BUFFER PIECE, 2" X 6" BY INSIDE CONTAINER HEIGHT MINUS 1/2" ( REF: 7'-10-1/2" ) ( 2 REQD ). NAIL TO THE BEAM ASSEMBLIES W/3-10d NAILS AT EACH JOINT.

LOAD BEARING PIECE, 2" X 6" X 7'-3" ( 4 REQD ). NAIL TO THE BEAM ASSEMBLIES W/3-10d NAILS AT EACH JOINT.

BEAM ASSEMBLY, 2" X 6" BY INSIDE CONTAINER WIDTH MINUS 1" ( REF: 7'-7" ) ( QUADRUPLED ) ( 4 REQD ). LAMINATE THE SECOND PIECE TO THE FIRST PIECE W/11-10d NAILS. LAMINATE EACH ADDITIONAL PIECE IN A LIKE MANNER.

STRUT LEDGER, 2" X 4" X 6" ( 8 REQD ). NAIL TO THE BUFFER PIECE W/2-10d NAILS, SEE THE SPECIAL NOTE ON PAGE 6.

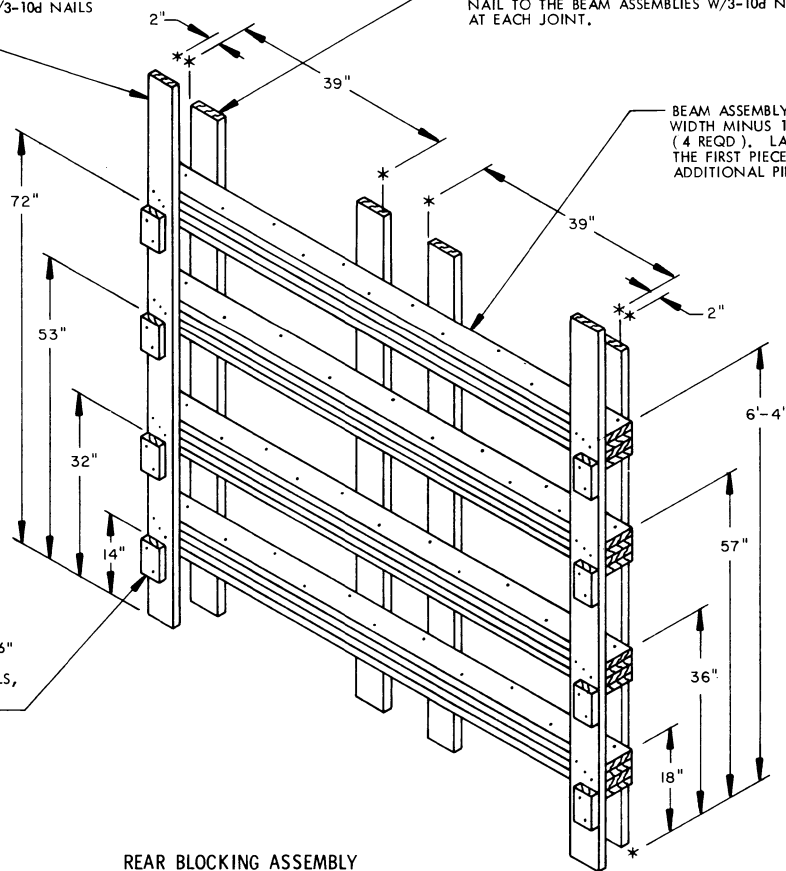

**REAR BLOCKING ASSEMBLY**

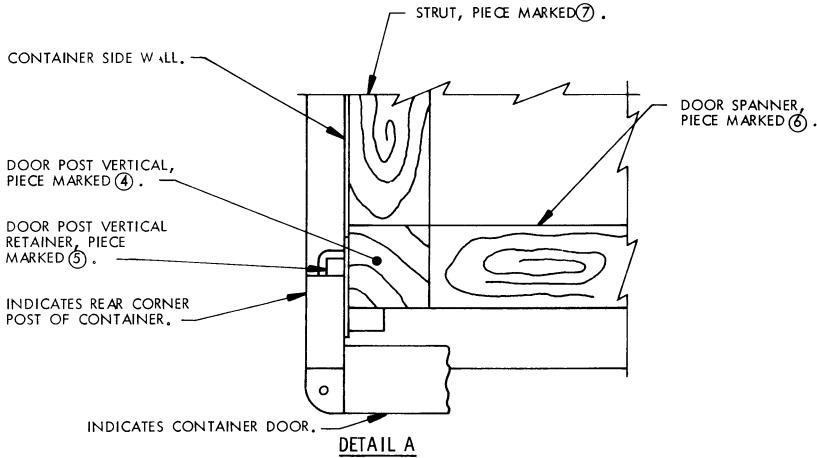

A PARTIAL PLAN VIEW OF THE LEFT REAR PORTION OF THE CONTAINER IS SHOWN DEPICTING THE PROPER POSITION OF THE DOOR POST VERTICAL AND ADJACENT DUNNAGE PIECES.

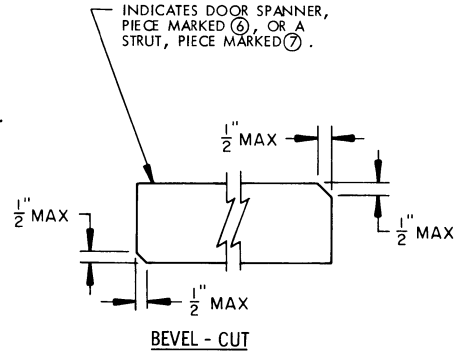

IF DESIRED, EACH END OF A DOOR SPANNER PIECE OR A STRUT MAY BE BEVEL-CUT AS SHOWN ABOVE TO FACILITATE THE ACHIEVEMENT OF A TIGHT DOOR-POST-TO-DOOR-POST FIT OR A TIGHT REAR-OF-LOAD FIT.

SPECIAL NOTE:

THE STRUT LEDGERS CAN ONLY BE PRE-NAILED TO THE DOOR POST VERTICAL ON ONE SIDE OF THE CONTAINER FOR THE DOOR SPANNER PIECES. ALSO, THE STRUT LEDGERS FOR THE STRUTS CAN ONLY BE PRE-NAILED TO THE REAR BLOCKING ASSEMBLY OR THE DOOR POST VERTICAL AT THE LOWEST DIMENSION.

