

APPROVED BY

U.S. COAST GUARD

NOTE: CONTAINERS OF AMMUNITION, CG CLASS II-B ARE AUTHORIZED BY TITLE 46 CFR (PARAGRAPH 146.29-42) FOR TRANSPORT BY WATER CARRIER WITHOUT THE SPECIFIC APPROVAL OF THE COAST GUARD.

APPROVED BY

BUREAU OF EXPLOSIVES

A. F. Grammuck
SUPERVISOR, MILITARY & INTERMODAL SERVICES

DATE *5/22/79*

LOADING AND BRACING WITH WOODEN DUNNAGE IN COMMERCIAL CONTAINERS OF SKIDDED UNITS OF 105MM AMMUNITION PACKED IN WOODEN BOXES (MIXED LOAD OF 15-BOX AND 9-BOX SKIDDED UNITS) ⊕

THE DEPICTED WOODEN DUNNAGE METHOD CAN BE APPLIED TO ANY COMMERCIAL INTERMODAL 20-FOOT CONTAINER, ALTHOUGH THE DUNNAGE DIMENSIONS HAVE BEEN GIVEN FOR A 92" WIDE BY 95" HIGH (INSIDE DIMENSIONS) CONTAINER. ALTHOUGH THE LOAD AS SHOWN IS BASED ON AN 8'-6" HIGH CONTAINER, AN 8'-0" HIGH CONTAINER IS PREFERRED FOR SHIPPING THE DEPICTED LOAD. WHEN AN 8'-0" HIGH CONTAINER IS USED, THE HEIGHT OF SOME DUNNAGE ASSEMBLIES WILL HAVE TO BE LOWERED BY REMOVING SOME MATERIAL FROM THE TOP OR BOTTOM OF SOME OF THE VERTICAL PIECES.

⊕ ALTHOUGH THE DEPICTED WOODEN DUNNAGE METHOD HAS BEEN SHOWN FOR A MIXED LOAD OF 15-BOX AND 9-BOX SKIDDED UNITS, THESE PROCEDURES CAN ALSO BE APPLIED TO A LOAD OF 12-BOX SKIDDED UNITS. THE BASIC LOAD CONFIGURATION WILL REMAIN THE SAME, HOWEVER, SOME ADJUSTMENTS TO THE DUNNAGE ASSEMBLIES WILL BE REQUIRED.

LOADING AND BRACING SPECIFICATIONS AS DELINEATED HEREIN ARE ADEQUATE FOR SHIPMENTS TO BE MOVED BY ANY SURFACE MODE OF TRANSPORT (MOTOR, RAIL, AND WATER).

REQUIREMENTS CITED WITHIN THE BUREAU OF EXPLOSIVES PAMPHLET 6C APPLY WHEN THE SHIPMENT MOVES BY TRAILER/CONTAINER-ON-FLAT-CAR (T/COFC). SPECIAL T/COFC NOTES FOLLOW.

- A. A LOADED CONTAINER MUST BE ON A CHASSIS EQUIPPED WITH TWO BOGIE ASSEMBLIES WHEN BEING MOVED IN TOFC SERVICE.
- B. THE LOAD LIMIT OF A T/COFC RAIL CAR MUST NOT BE EXCEEDED, NOR WILL A CAR BE LOADED SO THAT THE TRUCK UNDER ONE END OF THE CAR CARRIES MORE THAN ONE-HALF OF THE LOAD LIMIT FOR THAT CAR.

DURING INTRASTATE AND/OR INTERSTATE MOVES BY MOTOR CARRIER, A PROPER CHASSIS/MODIFIED FLAT BED TRAILER MUST BE USED TO PRECLUDE VIOLATION OF ONE OR MORE "WEIGHT LAWS" APPLICABLE TO THE STATE OR STATES INVOLVED.

REVISIONS				DRAFTSMAN <i>BR/MB</i>	PROJ ENG <i>WRF/WW</i>
				CHECKER <i>RSW</i>	LOG ENGRG OFFICE <i>WSE/Emmet</i>
APPROVED, U.S. ARMY ARMAMENT MATERIEL READINESS COMMAND					
APPROVED BY ORDER OF COMMANDING GENERAL, U.S. ARMY MATERIEL DEVELOPMENT AND READINESS COMMAND (DARCOM) <i>Del B. Law</i> U.S. ARMY DEFENSE AMMUNITION CENTER AND SCHOOL					
U.S. ARMY DARCOM DRAWING					
MAY 1979					
DEF AMMO CEN & SCH DWG NO.					
D-SARAC-4413					

DO NOT SCALE

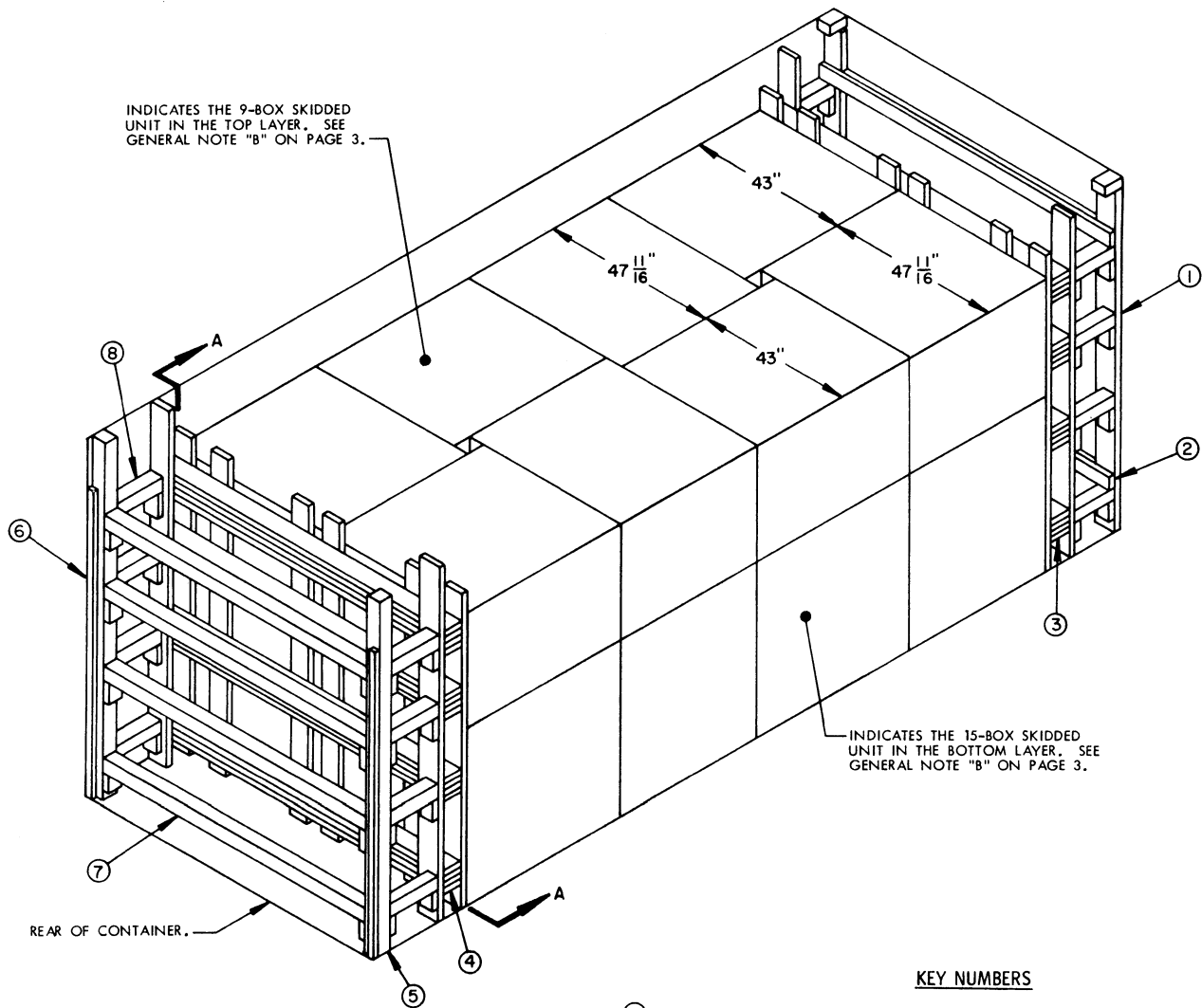

ISOMETRIC VIEW

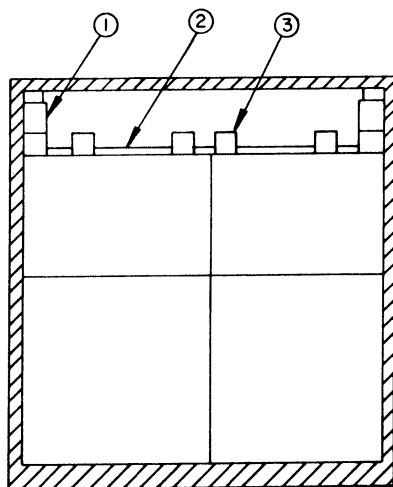

SECTION A-A

KEY NUMBERS

- ① FORWARD STRUT ASSEMBLY (2 REQD, 1 RIGHT HAND AND 1 LEFT HAND). SEE THE "FORWARD STRUT ASSEMBLY" DETAIL ON PAGE 4. POSITION THE ASSEMBLY WITH THE 4" X 4" STRUTS AGAINST THE CONTAINER SIDEWALL, AS SHOWN ABOVE. AFTER PIECE MARKED ③ IS INSTALLED AND CENTERED ON THE WIDTH OF THE CONTAINER, NAIL THROUGH THE REAR BUFFER PIECE OF EACH FORWARD STRUT ASSEMBLY INTO EACH BEAM ASSEMBLY OF PIECE MARKED ⑤ W/2-12d NAILS AT EACH JOINT.
- ② SPREADER ASSEMBLY (2 REQD). SEE THE "SPREADER ASSEMBLY" DETAIL ON PAGE 6. POSITION AS SHOWN, IMMEDIATELY ABOVE THE TOP AND BOTTOM STRUTS AND NAIL TO THE FORWARD STRUT ASSEMBLY W/2-10d NAILS AT EACH JOINT.
- ③ FORWARD BLOCKING ASSEMBLY (1 REQD). SEE THE "FORWARD BLOCKING ASSEMBLY" DETAIL ON PAGE 4 AND GENERAL NOTE "E" ON PAGE 3.
- ④ REAR BLOCKING ASSEMBLY (1 REQD). SEE THE "REAR BLOCKING ASSEMBLY" DETAIL ON PAGE 5 AND GENERAL NOTE "E" ON PAGE 3.
- ⑤ DOOR POST VERTICAL (2 REQD). SEE THE "DOOR POST VERTICAL" DETAIL ON PAGE 6 AND "DETAIL A" ON PAGE 5.
- ⑥ DOOR POST VERTICAL RETAINER (2 REQD). SEE THE "DOOR POST VERTICAL RETAINER" DETAIL ON PAGE 8. NAIL THROUGH THE HOLES INTO THE DOOR POST VERTICAL W/4-10d NAILS.
- ⑦ DOOR SPANNER, 4" X 4" MATERIAL, CUT TO A LENGTH THAT WILL PROVIDE FOR A DRIVE FIT (REF: 7"-1-3/8") (4 REQD). TOENAIL TO THE DOOR POST VERTICALS W/2-12d NAILS AT EACH END. SEE THE "BEVEL-CUT" DETAIL ON PAGE 5. AFTER INSTALLING THE BOTTOM AND THE TOP DOOR SPANNERS, THE STRUTS, PIECES MARKED ⑧, ARE TO BE INSTALLED.
- ⑧ STRUT, 4" X 4" BY CUT TO FIT (8 REQD). TOENAIL TO THE BUFFER PIECES OF THE REAR BLOCKING ASSEMBLY AND THE DOOR POST VERTICAL W/2-12d NAILS AT EACH END. SEE THE "BEVEL-CUT" DETAIL ON PAGE 5.

GENERAL NOTES

(GENERAL NOTES CONTINUED)

K. RECOMMENDED SEQUENTIAL LOADING PROCEDURES:

1. PREFABRICATE ONE RIGHT HAND AND ONE LEFT HAND FORWARD STRUT ASSEMBLY, TWO SPREADER ASSEMBLIES, ONE FORWARD BLOCKING ASSEMBLY, ONE REAR BLOCKING ASSEMBLY, AND NAIL A DOOR POST VERTICAL RETAINER TO EACH DOOR POST VERTICAL, ONE RIGHT HAND AND ONE LEFT HAND.
2. INSTALL THE TWO FORWARD STRUT ASSEMBLIES (ONE RIGHT HAND AND ONE LEFT HAND) AND TWO SPREADER ASSEMBLIES.
3. INSTALL FORWARD BLOCKING ASSEMBLY.
4. LOAD SIXTEEN SKIDDED UNITS, EIGHT 15-BOX UNITS AND EIGHT 9-BOX UNITS.
5. INSTALL REAR BLOCKING ASSEMBLY.
6. INSTALL THE TWO DOOR POST VERTICAL ASSEMBLIES (ONE RIGHT HAND AND ONE LEFT HAND).
7. INSTALL TWO DOOR SPANNER PIECES (ONE AT THE LOWEST POSITION AND ONE AT THE UPPERMOST POSITION).
8. INSTALL THE STRUTS BETWEEN THE REAR BLOCKING ASSEMBLY AND THE DOOR POST VERTICALS.
9. INSTALL REMAINING DOOR SPANNER PIECES.

- A. THIS DOCUMENT HAS BEEN PREPARED AND ISSUED IN ACCORDANCE WITH AR 740-1, AND AUGMENTS TM 743-200-1 (CHAPTER 5).
- B. THE SPECIFIED OUTLOADING PROCEDURE IS APPLICABLE TO A MIXED LOAD OF 15-BOX AND 9-BOX SKIDDED UNITS OF 105MM AMMUNITION. NOTICE: THE PROCEDURES DEPICTED WITHIN THIS DRAWING CAN ALSO BE APPLIED TO A LOAD OF 12-BOX SKIDDED UNITS. SEE SPECIAL NOTE 2 ON PAGE 4. SUBSEQUENT REFERENCE TO SKIDDED UNIT MEANS THE SKIDDED UNIT WITH AMMUNITION ITEMS. SEE PAGE 7 FOR DETAILS OF THE SKIDDED UNITS. CAUTION: REGARDLESS OF THE QUANTITY OF UNITS TO BE SHIPPED, THE "MAXIMUM GROSS WEIGHT" OF 44,300 POUNDS MUST NOT BE EXCEEDED.
- C. THE LOAD AS SHOWN IS BASED ON A 4,700 POUND 20' LONG BY 8' WIDE BY 8'-6" HIGH INTERMODAL COMMERCIAL CONTAINER WITH INSIDE DIMENSIONS OF 19'-4" LONG BY 92" WIDE BY 95" HIGH. THE LOAD IS DESIGNED FOR TRAILER/CONTAINER-ON-FLAT CAR (T/COFC) SHIPMENT, HOWEVER, THE LOAD AS DESIGNED CAN ALSO BE MOVED BY OTHER SURFACE MODES OF TRANSPORT. NOTICE: OTHER CONTAINERS OF THE SAME CONFIGURATION DESIGN CAN BE USED.
- D. DUNNAGE LUMBER SPECIFIED IS OF NOMINAL SIZE. FOR EXAMPLE, 2" X 6" MATERIAL IS ACTUALLY 1-1/2" THICK BY 5-1/2" WIDE.
- E. A STAGGERED NAILING PATTERN WILL BE USED WHEREVER POSSIBLE WHEN NAILS ARE DRIVEN INTO JOINTS OF DUNNAGE ASSEMBLIES OR WHEN LAMINATING DUNNAGE. ADDITIONALLY, THE NAILING PATTERN FOR AN UPPER PIECE OF LAMINATED DUNNAGE WILL BE ADJUSTED AS REQUIRED SO THAT A NAIL FOR THAT PIECE WILL NOT BE DRIVEN THROUGH ONTO OR RIGHT BESIDE A NAIL IN A LOWER PIECE.
- F. IN SOME CONTAINERS, SUCH AS SOME ALL STEEL CONTAINERS, THERE IS A SLOT AT THE CORNERS OF THE FORWARD WALL. A PIECE OF DUNNAGE MATERIAL MUST BE LAMINATED TO THE BUFFER PIECES ON THE FORWARD STRUT ASSEMBLY TO PROVIDE A FLAT SURFACE FOR THE 2" X 6" BUFFER PIECES. A PIECE OF 2" X 4", 2" X 3", OR A SPECIAL WIDTH PIECE CUT TO FIT CAN BE USED. THIS FILL PIECE WILL BE NAILED WITH ONE APPROPRIATELY SIZED NAIL EVERY 12". THIS PIECE IS NOT REQUIRED WHEN THE FRONT WALL OF THE CONTAINER IS SMOOTH AND FLAT.
- G. CAUTION: DO NOT NAIL DUNNAGE MATERIAL TO THE CONTAINER WALLS OR FLOOR. ALL NAILING WILL BE WITHIN THE DUNNAGE.
- H. PORTIONS OF THE CONTAINERS DEPICTED WITHIN THIS DRAWING, SUCH AS ONE OF THE SIDE WALLS, HAVE NOT BEEN SHOWN IN THE LOAD VIEWS FOR CLARITY PURPOSES.
- J. TO MAKE LOADING EASIER, TO HELP ACHIEVE A TIGHT LOAD ACROSS A CONTAINER AND TO PREVENT UNACCEPTABLE DAMAGE TO LADING UNITS WHEN LOADING A CONTAINER, A SLIP-SHEET CAN BE USED EFFECTIVELY AS A "SHOE-HORN" TYPE DEVICE. THE SLIP-SHEET WILL PROVIDE A SMOOTH SURFACE THAT WILL PREVENT UNIT STRAPS AND/OR BOXES FROM INTERLOCKING OR CATCHING ON OTHER PROJECTIONS WHEN LATERALLY ADJACENT LADING UNITS ARE BEING LOADED. A SLIP-SHEET WILL BE USED AFTER ONE-HALF OF A STACK IS LOADED WITH ONE OF ITS SIDES IN TIGHT CONTACT AT ONE SIDE OF THE CONTAINER. THE SLIP-SHEET IS TO BE PLACED AGAINST THE OTHER SIDE OF THE HALF-STACK BEFORE THE LAST HALF OF THE STACK IS LOADED. AFTER A STACK IS COMPLETED, THE SLIP-SHEET IS TO BE REMOVED FOR SUBSEQUENT USE WITH THE NEXT STACK. A SLIP-SHEET OF SUITABLE SIZE CAN BE MADE FROM A SHEET OF 1/8" TEMPERED HARDBOARD (MASONITE) OR FROM A SHEET OF ANY OTHER MATERIAL THAT WILL SATISFY THE REQUIREMENT.

BILL OF MATERIAL

LUMBER	LINEAR FEET	BOARD FEET
2" X 4"	49	33
2" X 6"	374	374
4" X 4"	63	84
NAILS	NO. REQD	POUNDS
10d (3")	574	8-3/4
12d (3-1/4")	64	1
DOOR POST VERTICAL RETAINER -- 2 REQD ----- 64 LBS		

(CONTINUED AT LEFT)

MATERIAL SPECIFICATIONS

- LUMBER** ----- : TM 743-200-1 (DUNNAGE LUMBER) AND FED SPEC MM-L-751.
- NAILS** ----- : FED SPEC FF-N-105; COMMON.
- STEEL, STRUCTURAL** ----- : FED SPEC QQ-5-741; SQUARE STRUCTURAL TUBING AND ROLLED PLATE.

LOAD AS SHOWN

ITEM	QUANTITY	WEIGHT (APPROX)
15-BOX SKIDDED UNIT	8	17,256 LBS
9-BOX SKIDDED UNIT	8	10,488 LBS
DUNNAGE		1,056 LBS
CONTAINER		4,700 LBS
TOTAL WEIGHT		33,500 LBS

LOAD AS SHOWN

ITEM	QUANTITY	WEIGHT (APPROX)
12-BOX SKIDDED UNIT	16	27,744 LBS
DUNNAGE		1,056 LBS
CONTAINER		4,700 LBS
TOTAL WEIGHT		33,500 LBS

FORWARD BUFFER PIECE,
2" X 6" X 7'-7-1/2" (1 REQD).
NAIL TO THE STRUTS
W/2-10d NAILS AT EACH JOINT.

SEE GENERAL NOTE
"F" ON PAGE 3.

REAR BUFFER PIECE,
2" X 6" X 7'-10-1/2" (1 REQD). NAIL
TO THE STRUTS W/2-10d
NAILS AT EACH JOINT.

SEE SPECIAL
NOTE 2 AT RIGHT.

STRUT, 4" X 4"
X 12" (4 REQD).

STRUT LEDGER, 2" X 4"
X 6" (8 REQD). NAIL
TO THE BUFFER PIECE
W/2-10d NAILS.

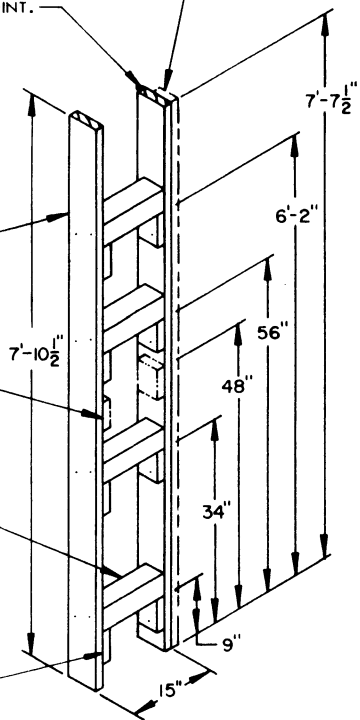

SPECIAL NOTES:

1. THE STRUT LEDGERS CAN ONLY BE PRE-NAILED TO THE DOOR POST VERTICAL ON ONE SIDE OF THE CONTAINER FOR THE DOOR SPANNER PIECES. ALSO, THE STRUT LEDGERS FOR THE STRUTS CAN ONLY BE PRE-NAILED TO THE REAR BLOCKING ASSEMBLY OR THE DOOR POST VERTICAL AT THE LOWEST DIMENSION.
2. WHEN THE DELINEATED OUTLOADING PROCEDURES ARE TO BE USED FOR A LOAD OF 12-BOX SKIDDED UNITS, THE FOLLOWING ADJUSTMENTS MUST BE MADE TO THE DUNNAGE ASSEMBLIES:
 - A. THE STRUT LEDGERS SHOWN AT THE 48" DIMENSION ON THE FORWARD STRUT ASSEMBLY, PIECE MARKED ①, REAR BLOCKING ASSEMBLY, PIECE MARKED ④, AND DOOR POST VERTICAL, PIECE MARKED ⑤, WILL BE USED IN LIEU OF THE STRUT LEDGERS LOCATED AT THE 56" DIMENSION.
 - B. THE BEAM ASSEMBLY SHOWN AT THE 52" DIMENSION ON THE FORWARD BLOCKING ASSEMBLY, PIECE MARKED ③, AND REAR BLOCKING ASSEMBLY, PIECE MARKED ④, WILL BE USED IN LIEU OF THE BEAM ASSEMBLY LOCATED AT THE 60" DIMENSION.
3. WHEN AN 8'-0" HIGH CONTAINER IS BEING USED FOR SHIPPING THE DEPICTED LOAD, THE HEIGHT OF SOME OF THE DUNNAGE ASSEMBLIES MUST BE LOWERED BY REMOVING SOME MATERIAL FROM THE TOP OF THE VERTICAL PIECES.

FORWARD STRUT ASSEMBLY

A "RIGHT HAND" FORWARD STRUT ASSEMBLY IS DEPICTED. A "LEFT HAND" ASSEMBLY IS ALSO REQUIRED AND WILL BE THE SAME AS THE ASSEMBLY DEPICTED ABOVE, EXCEPT THE 4" X 4" STRUTS AND STRUT LEDGERS ARE ALIGNED ON THE OPPOSITE SIDE OF THE BUFFER PIECES.

BEAM ASSEMBLY, 2" X 6" BY INSIDE
CONTAINER WIDTH MINUS 1" (REF: 7'-7")
(QUADRUPLED) (4 REQD). LAMINATE
THE SECOND PIECE TO THE FIRST
PIECE W/11-10d NAILS. LAMINATE EACH
ADDITIONAL PIECE IN A LIKE MANNER.

LOAD BEARING PIECE,
2" X 6" X 7'-0" (6 REQD).
NAIL TO THE BEAM
ASSEMBLIES W/3-10d
NAILS AT EACH JOINT.

SEE SPECIAL
NOTE 2 ABOVE.

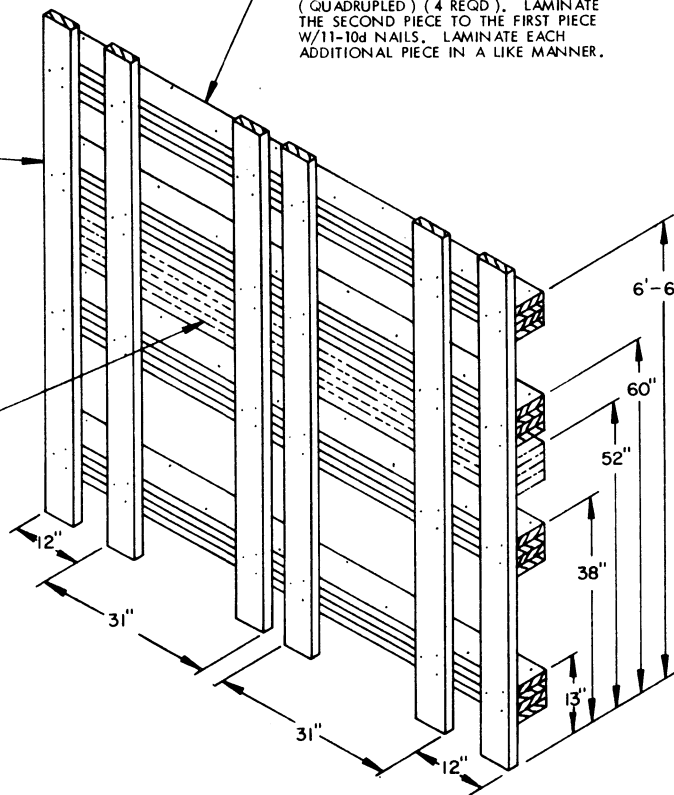

FORWARD BLOCKING ASSEMBLY

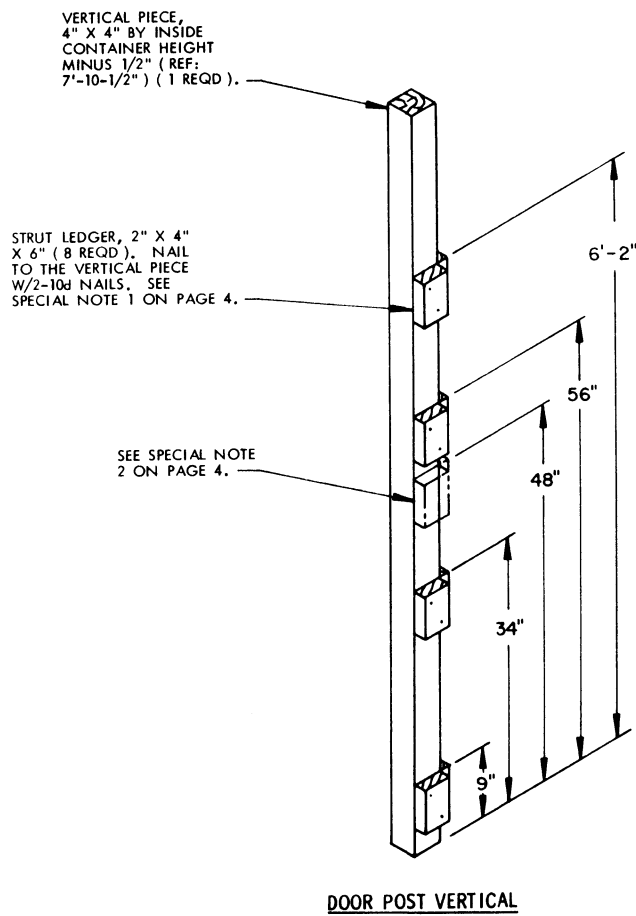
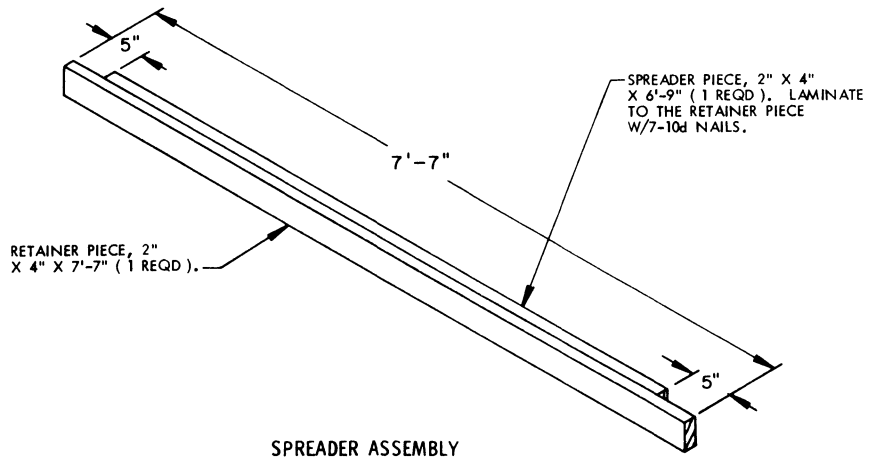

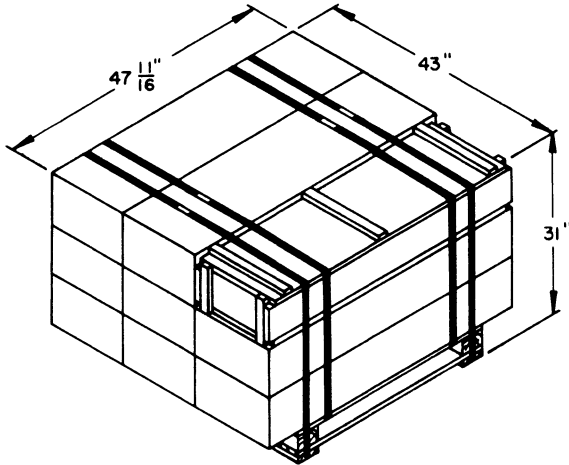

SKIDDED UNIT

UNIT WEIGHT ----- 1,311 LBS (APPROX)
 CU BE ----- 36.8 CUBIC FEET

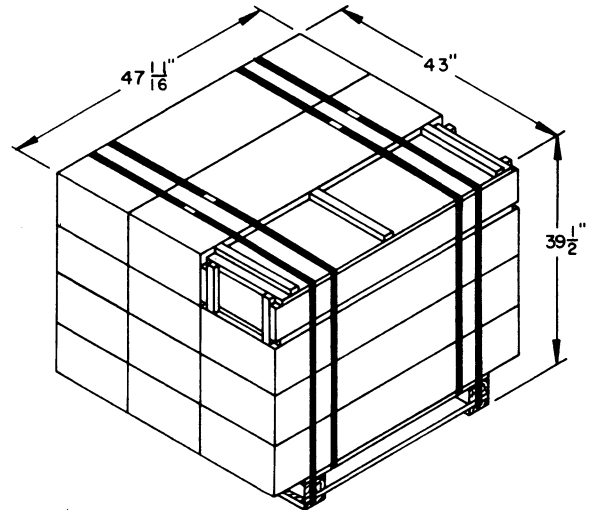

SKIDDED UNIT

UNIT WEIGHT ----- 1,734 LBS (APPROX)
 CU BE ----- 46.9 CUBIC FEET

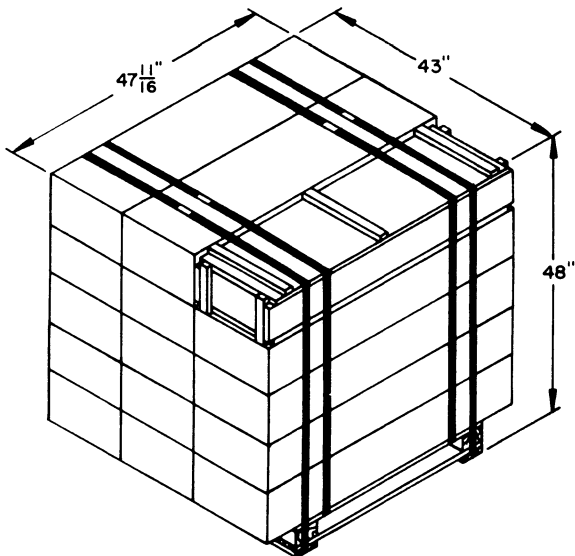

SKIDDED UNIT

UNIT WEIGHT ----- 2,157 LBS (APPROX)
 CU BE ----- 57 CUBIC FEET

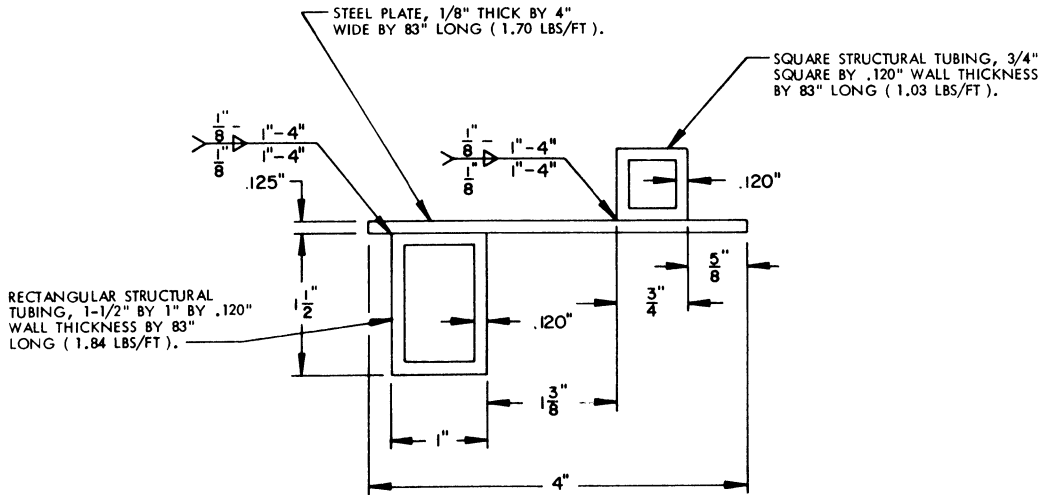

VIEW A

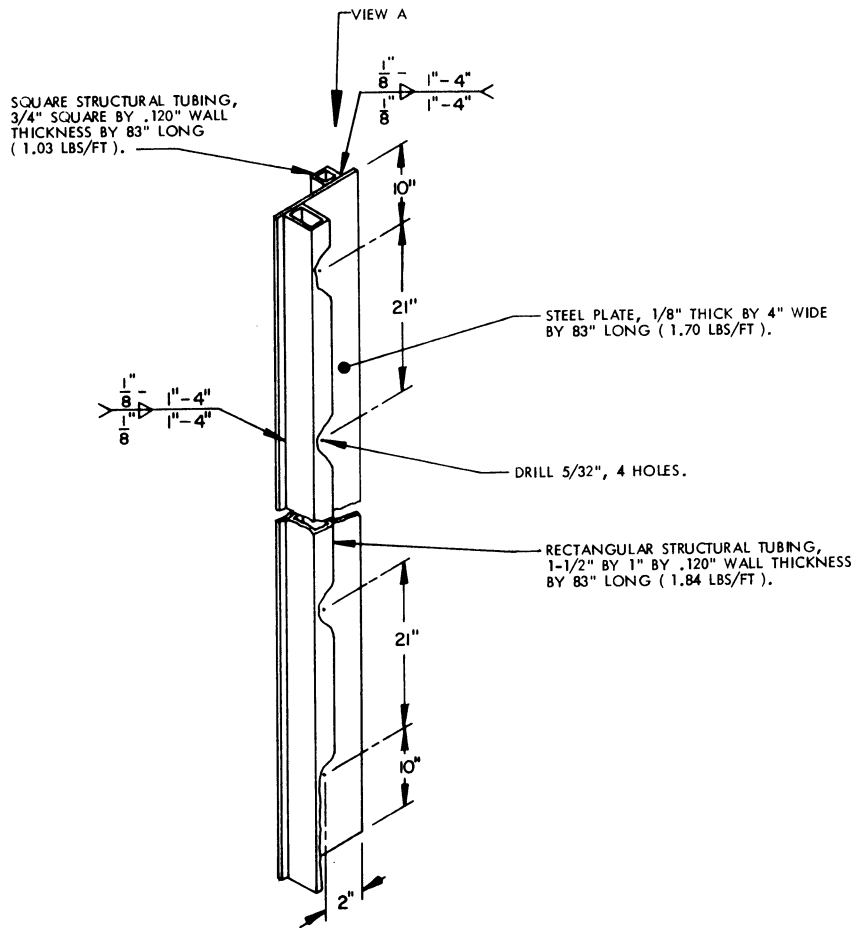

DOOR POST VERTICAL RETAINER