

APPROVED BY U.S. COAST GUARD <i>E. H. Hibson</i>	APPROVED BY BUREAU OF EXPLOSIVES <i>A. J. Grammuck</i>
DATE <i>8/2/79</i>	DATE <i>7/19/79</i>

LOADING AND BRACING WITH WOODEN DUNNAGE IN COMMERCIAL CONTAINERS OF SKIDDED UNITS OF 105MM AMMUNITION PACKED IN WOODEN BOXES (15-BOX SKIDDED UNIT) (METHOD 2)

THE DEPICTED WOODEN DUNNAGE METHOD CAN BE APPLIED TO ANY 8'-6" HIGH COMMERCIAL INTERMODAL 20-FOOT CONTAINER, ALTHOUGH THE DUNNAGE DIMENSIONS HAVE BEEN GIVEN FOR A 92" WIDE BY 95" HIGH (INSIDE DIMENSIONS) CONTAINER. WHEN THE INSIDE CONTAINER HEIGHT IS LESS THAN 95", THE HEIGHT OF SOME DUNNAGE ASSEMBLIES WILL HAVE TO BE LOWERED BY REMOVING SOME MATERIAL FROM THE TOP OR BOTTOM OF SOME OF THE VERTICAL PIECES.

LOADING AND BRACING SPECIFICATIONS AS DELINEATED HEREIN ARE ADEQUATE FOR SHIPMENTS TO BE MOVED BY ANY SURFACE MODE OF TRANSPORT (MOTOR, RAIL, AND WATER).

REQUIREMENTS CITED WITHIN THE BUREAU OF EXPLOSIVES PAMPHLET 6C APPLY WHEN THE SHIPMENT MOVES BY TRAILER/CONTAINER-ON-FLAT-CAR (T/COFC). SPECIAL T/COFC NOTES FOLLOW.

- A. A LOADED CONTAINER MUST BE ON A CHASSIS EQUIPPED WITH TWO BOGIE ASSEMBLIES (TANDEM AXLES) WHEN BEING MOVED IN TOFC SERVICE.
- B. THE LOAD LIMIT OF A T/COFC RAIL CAR MUST NOT BE EXCEEDED, NOR WILL A CAR BE LOADED SO THAT THE TRUCK UNDER ONE END OF THE CAR CARRIES MORE THAN ONE-HALF OF THE LOAD LIMIT FOR THAT CAR.

DURING INTRASTATE AND/OR INTERSTATE MOVES BY MOTOR CARRIER, A PROPER CHASSIS/MODIFIED FLAT BED TRAILER MUST BE USED TO PRECLUDE VIOLATION OF ONE OR MORE "WEIGHT LAWS" APPLICABLE TO THE STATE OR STATES INVOLVED.

NOTICE:

DRAWING D-SARAC-4358 ALSO SPECIFIED OUTLOADING PROCEDURES APPLICABLE TO SHIPMENT BY T/COFC OF SKIDDED UNITS OF 105MM AMMUNITION IN COMMERCIAL CONTAINERS. HOWEVER, D-SARAC-4358 DEPICTS INTERIM PROCEDURES FOR ONE TIME USE IN SUPPORT OF A TRIAL SHIPMENT PROGRAM. UNLESS OTHERWISE DIRECTED, ONLY DRAWING D-SARAC-4411 IS APPROVED FOR USE.

* CAUTION: ONLY CONTAINERS WITH A MINIMUM INSIDE HEIGHT DIMENSION OF 93" AND A MINIMUM DOOR OPENING HEIGHT DIMENSION OF 90" CAN BE USED TO ACHIEVE THE TWO-HIGH SKIDDED UNIT LOAD CONFIGURATION DEPICTED HEREIN.

REVISIONS		DRAFTSMAN <i>BK ADP</i>	PROJ. ENG. <i>WJRE/MLM</i>
		CHECKER <i>GES</i>	LOG. ENGRG. OFFICE <i>W. J. Conant</i>
		APPROVED, U.S. ARMY ARMAMENT MATERIEL READINESS COMMAND <i>David J. Fetter</i>	
		APPROVED BY ORDER OF COMMANDING GENERAL, U.S. ARMY MATERIEL DEVELOPMENT AND READINESS COMMAND (DARCOM) <i>John L. Breyer</i>	
		U.S. ARMY DEFENSE AMMUNITION CENTER AND SCHOOL	
		U.S. ARMY DARCOM DRAWING	
		AUGUST 1979	
		DEF AMMO CEN & SCH DWG NO.	
		D-SARAC-4411	

DO NOT SCALE

INDICATES A SKIDDED UNIT. SEE THE "SKIDDED UNIT" DETAIL ON PAGE 8 FOR THE SPECIFIC UNIT CONFIGURATION AND OTHER PERTINENT DATA.

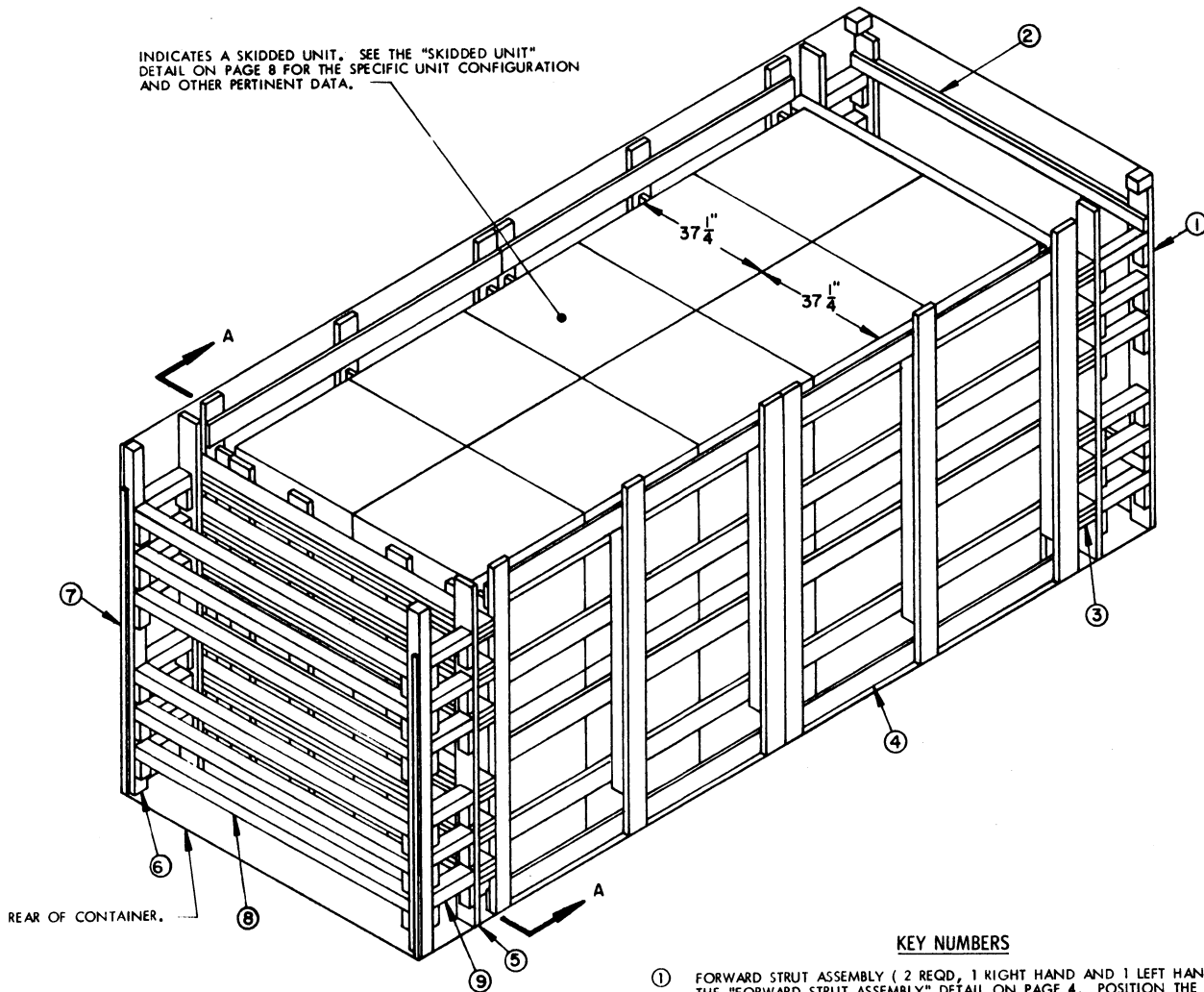

ISOMETRIC VIEW

KEY NUMBERS

- ① FORWARD STRUT ASSEMBLY (2 REQD, 1 RIGHT HAND AND 1 LEFT HAND). SEE THE "FORWARD STRUT ASSEMBLY" DETAIL ON PAGE 4. POSITION THE ASSEMBLY WITH THE 4" X 4" STRUTS AGAINST THE CONTAINER SIDEWALL, AS SHOWN ABOVE. AFTER PIECE ③ IS INSTALLED AND CENTERED ON THE WIDTH OF THE CONTAINER, NAIL THROUGH THE REAR BUFFER PIECE OF EACH FORWARD STRUT ASSEMBLY INTO EACH BEAM ASSEMBLY OF PIECE MARKED ③ W/2-12d NAILS AT EACH JOINT.
- ② SPREADER ASSEMBLY (2 REQD). SEE THE "SPREADER ASSEMBLY" DETAIL ON PAGE 8. POSITION AS SHOWN, IMMEDIATELY ABOVE THE TOP AND BOTTOM STRUTS AND NAIL TO THE FORWARD STRUT ASSEMBLY W/2-10d NAILS AT EACH JOINT.
- ③ FORWARD BLOCKING ASSEMBLY (1 REQD). SEE THE "FORWARD BLOCKING ASSEMBLY" DETAIL ON PAGE 4 AND GENERAL NOTE "F" ON PAGE 3.
- ④ SIDE FILL ASSEMBLY (4 REQD). SEE THE "SIDE FILL ASSEMBLY" DETAIL ON PAGE 5 AND GENERAL NOTE "D" ON PAGE 3.
- ⑤ REAR BLOCKING ASSEMBLY (1 REQD). SEE THE "REAR BLOCKING ASSEMBLY" DETAIL ON PAGE 5 AND GENERAL NOTE "F" ON PAGE 3.
- ⑥ DOOR POST VERTICAL (2 REQD). SEE THE "DOOR POST VERTICAL" DETAIL AND "DETAIL A" ON PAGE 7.
- ⑦ DOOR POST VERTICAL RETAINER (2 REQD). SEE THE "DOOR POST VERTICAL RETAINER" DETAIL ON PAGE 6. NAIL THROUGH THE HOLES INTO THE DOOR POST VERTICAL W/4-10d NAILS.
- ⑧ DOOR SPANNER, 4" X 4" MATERIAL, CUT TO A LENGTH THAT WILL PROVIDE FOR A DRIVE FIT (REF: 7'-1-3/8") (6 REQD). TOENAIL TO THE DOOR POST VERTICALS W/2-12d NAILS AT EACH END. SEE THE "BEVEL-CUT" DETAIL ON PAGE 7. AFTER INSTALLING THE BOTTOM AND THE TOP DOOR SPANNERS, THE STRUTS, PIECES MARKED ⑨, ARE TO BE INSTALLED.
- ⑨ STRUT, 4" X 4" BY CUT TO FIT (12 REQD). TOENAIL TO THE BUFFER PIECES OF THE REAR BLOCKING ASSEMBLY AND THE DOOR POST VERTICAL W/2-12d NAILS AT EACH END. SEE THE "BEVEL-CUT" DETAIL ON PAGE 7.

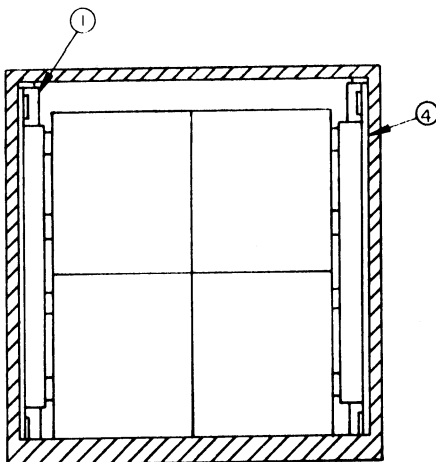

SECTION A-A

(GENERAL NOTES CONTINUED)

L. RECOMMENDED SEQUENTIAL LOADING PROCEDURES:

1. PREFABRICATE ONE RIGHT HAND AND ONE LEFT HAND FORWARD STRUT ASSEMBLY, TWO SPREADER ASSEMBLIES, ONE FORWARD BLOCKING ASSEMBLY, FOUR SIDE FILL ASSEMBLIES, ONE REAR BLOCKING ASSEMBLY, AND NAIL A DOOR POST VERTICAL RETAINER TO EACH DOOR POST VERTICAL, ONE RIGHT HAND AND ONE LEFT HAND.
2. INSTALL THE TWO FORWARD STRUT ASSEMBLIES (ONE RIGHT HAND AND ONE LEFT HAND) AND TWO SPREADER ASSEMBLIES.
3. INSTALL FORWARD BLOCKING ASSEMBLY.
4. INSTALL TWO SIDE FILL ASSEMBLIES AND LOAD EIGHT SKIDDED UNITS.
5. INSTALL TWO SIDE FILL ASSEMBLIES AND LOAD TWELVE SKIDDED UNITS.
6. INSTALL REAR BLOCKING ASSEMBLY.
7. INSTALL THE TWO DOOR POST VERTICAL ASSEMBLIES (ONE RIGHT HAND AND ONE LEFT HAND) .
8. INSTALL TWO DOOR SPANNER PIECES (ONE AT THE LOWEST POSITION AND ONE AT THE UPPERMOST POSITION) .
9. INSTALL THE STRUTS BETWEEN THE REAR BLOCKING ASSEMBLY AND THE DOOR POST VERTICALS.
10. INSTALL REMAINING DOOR SPANNER PIECES.

GENERAL NOTES

- A. THIS DOCUMENT HAS BEEN PREPARED AND ISSUED IN ACCORDANCE WITH AR 740-1 AND AUGMENTS TM 743-200-1 (CHAPTER 5).
- B. THE SPECIFIED OUTLOADING PROCEDURE IS APPLICABLE TO A LOAD OF 15-BOX SKIDDED UNITS OF 105MM AMMUNITION PACKED IN WOODEN BOXES. SUBSEQUENT REFERENCE TO SKIDDED UNIT MEANS THE SKIDDED UNIT WITH AMMUNITION ITEMS. SEE PAGE 8 FOR THE DETAIL OF THE SKIDDED UNIT. CAUTION: REGARDLESS OF THE QUANTITY OF UNITS TO BE SHIPPED, THE "MAXIMUM GROSS WEIGHT" OF 44,800 POUNDS MUST NOT BE EXCEEDED.
- C. THE LOAD AS SHOWN IS BASED ON A 4,700 POUND 20' LONG BY 8' WIDE BY 8'-6" HIGH INTERMODAL COMMERCIAL CONTAINER WITH INSIDE DIMENSIONS OF 19'-4" LONG BY 92" WIDE BY 95" HIGH. CAUTION: ONLY CONTAINERS WITH A MINIMUM INSIDE HEIGHT DIMENSION OF 93" CAN BE USED TO ACHIEVE THE TWO-HIGH SKIDDED UNIT LOAD CONFIGURATION DEPICTED HEREIN. THE LOAD IS DESIGNED FOR TRAILER/CONTAINER-ON-FLAT-CAR (T/COFC) SHIPMENT, HOWEVER, THE LOAD AS DESIGNED CAN ALSO BE MOVED BY OTHER SURFACE MODES OF TRANSPORT. NOTICE: OTHER CONTAINERS OF THE SAME DESIGN CONFIGURATION CAN BE USED.
- D. WHEN LOADING SKIDDED UNITS, THEY ARE TO BE POSITIONED SO AS TO ACHIEVE A TIGHT LOAD (TIGHT AGAINST THE FORWARD AND SIDE DUNNAGE ASSEMBLIES). ALTHOUGH A TOTAL OF ONE AND ONE-HALF INCHES (1-1/2") OF UNBLOCKED SPACE ACROSS THE WIDTH OF A LOAD BAY IS PERMITTED, LATERAL VOIDS WITHIN THE LOAD ARE TO BE HELD TO A MINIMUM. WHEN THE UNIT WIDTH IS LESS THAN 37-1/4", EXCESSIVE SLACK CAN BE ELIMINATED FROM A LOAD BAY BY LAMINATING ADDITIONAL PIECES OF APPROPRIATE THICKNESS TO THE LOAD BEARING PIECES ON A SIDE FILL ASSEMBLY. NAIL EACH ADDITIONAL PIECE TO THE BEARING PIECE W/1 APPROPRIATELY SIZED NAIL EVERY 12". IF THE UNIT WIDTH IS GREATER THAN 37-1/4" OR THE CONTAINER WIDTH IS LESS THAN 92", IT MAY BE NECESSARY TO USE 2" X 5" MATERIAL IN LIEU OF THE SPECIFIED 2" X 6" SPACER PIECES ON A SIDE FILL ASSEMBLY.
- E. DUNNAGE LUMBER SPECIFIED IS OF A NOMINAL SIZE. FOR EXAMPLE, 1" X 6" MATERIAL IS ACTUALLY 3/4" THICK BY 5-1/2" WIDE AND 2" X 6" MATERIAL IS ACTUALLY 1-1/2" THICK BY 5-1/2" WIDE.
- F. A STAGGERED NAILING PATTERN WILL BE USED WHEREVER POSSIBLE WHEN NAILS ARE DRIVEN INTO JOINTS OF DUNNAGE ASSEMBLIES OR WHEN LAMINATING DUNNAGE. ADDITIONALLY, THE NAILING PATTERN FOR AN UPPER PIECE OF LAMINATED DUNNAGE WILL BE ADJUSTED AS REQUIRED SO THAT A NAIL FOR THAT PIECE WILL NOT BE DRIVEN THROUGH ONTO OR RIGHT BESIDE A NAIL IN A LOWER PIECE.
- G. IN SOME CONTAINERS, SUCH AS SOME ALL STEEL CONTAINERS, THERE IS A SLOT AT THE CORNERS OF THE FORWARD WALL. A PIECE OF DUNNAGE MATERIAL MUST BE LAMINATED TO THE FORWARD BUFFER PIECE ON THE FORWARD STRUT ASSEMBLIES TO PROVIDE A FLAT SURFACE FOR THE 2" X 6" BUFFER PIECES. A PIECE OF 2" X 4", 2" X 3", OR A SPECIAL WIDTH PIECE CUT TO FIT CAN BE USED. THIS FILL PIECE WILL BE NAILED WITH ONE APPROPRIATELY SIZED NAIL EVERY 12". THIS PIECE IS NOT REQUIRED WHEN THE FRONT WALL OF THE CONTAINER IS SMOOTH AND FLAT.
- H. CAUTION: DO NOT NAIL DUNNAGE MATERIAL TO THE CONTAINER WALLS OR FLOOR. ALL NAILING WILL BE WITHIN THE DUNNAGE.
- J. PORTIONS OF THE CONTAINERS DEPICTED WITHIN THIS DRAWING, SUCH AS ONE OF THE SIDE WALLS, HAVE NOT BEEN SHOWN IN THE LOAD VIEWS FOR CLARITY PURPOSES.
- K. TO MAKE LOADING EASIER, TO HELP ACHIEVE A TIGHT LOAD ACROSS A CONTAINER, AND TO PREVENT UNACCEPTABLE DAMAGE TO LADING UNITS WHEN LOADING A CONTAINER, A SLIP-SHEET CAN BE USED EFFECTIVELY AS A "SHOEHORN" TYPE DEVICE. THE SLIP-SHEET WILL PROVIDE A SMOOTH SURFACE THAT WILL PREVENT UNIT STRAPS AND/OR DUNNAGE PIECES FROM INTERLOCKING OR CATCHING ON OTHER PROJECTIONS WHEN LATERALLY ADJACENT LADING UNITS ARE BEING LOADED. A SLIP-SHEET WILL BE USED AFTER ONE-HALF OF A STACK IS LOADED WITH ONE OF ITS SIDES IN TIGHT CONTACT AT ONE SIDE OF THE CONTAINER. THE SLIP-SHEET IS TO BE PLACED AGAINST THE OTHER SIDE OF THE HALF-STACK BEFORE THE LAST HALF OF THE STACK IS LOADED. AFTER A STACK IS COMPLETED, THE SLIP-SHEET IS TO BE REMOVED FOR SUBSEQUENT USE WITH THE NEXT STACK. A SLIP-SHEET OF SUITABLE SIZE CAN BE MADE FROM A SHEET OF 1/8" TEMPERED HARDBOARD (MASONITE) OR FROM A SHEET OF ANY OTHER MATERIAL THAT WILL SATISFY THE REQUIREMENT.

(CONTINUED AT LEFT)

BILL OF MATERIAL		
LUMBER	LINEAR FEET	BOARD FEET
1" X 6"	62	31
2" X 4"	59	40
2" X 6"	665	665
4" X 4"	84	112
NAILS	NO. REQD	POUNDS
6d (2")	72	1/2
10d (3")	882	13-3/4
12d (3-1/4")	72	1-1/4
DOOR POST VERTICAL RETAINER --- 2 REQD -----		64 LBS

MATERIAL SPECIFICATIONS

- LUMBER ----- : TM 743-200-1 (DUNNAGE LUMBER) AND FED SPEC MM-L-751.
- NAILS ----- : FED SPEC FF-N-105; COMMON.
- STEEL, STRUCTURAL ----- : FED SPEC QQ-S-741; SQUARE STRUCTURAL TUBING AND ROLLED PLATE.

LOAD AS SHOWN

ITEM	QUANTITY	WEIGHT (APPROX)
SKIDDED UNIT -----	20 -----	33,800 LBS
DUNNAGE -----	-----	1,776 LBS
CONTAINER -----	-----	4,700 LBS
TOTAL WEIGHT -----		40,276 LBS

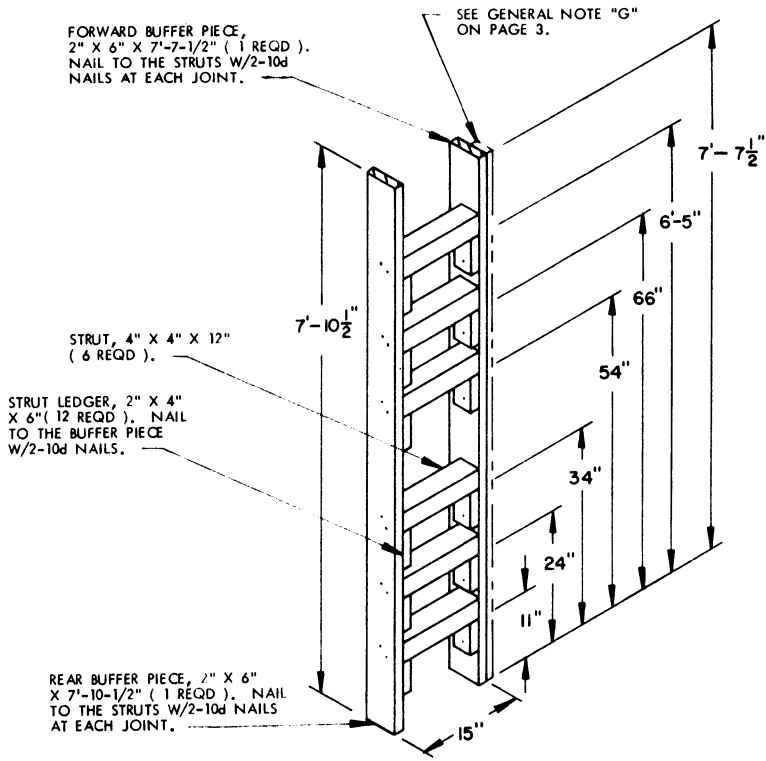

FORWARD STRUT ASSEMBLY

A "RIGHT HAND" FORWARD STRUT ASSEMBLY IS DEPICTED. A "LEFT HAND" ASSEMBLY IS ALSO REQUIRED AND WILL BE THE SAME AS THE ASSEMBLY DEPICTED ABOVE, EXCEPT THE 4" X 4" STRUTS AND STRUT LEDGERS ARE ALIGNED ON THE OPPOSITE SIDE OF THE BUFFER PIECES.

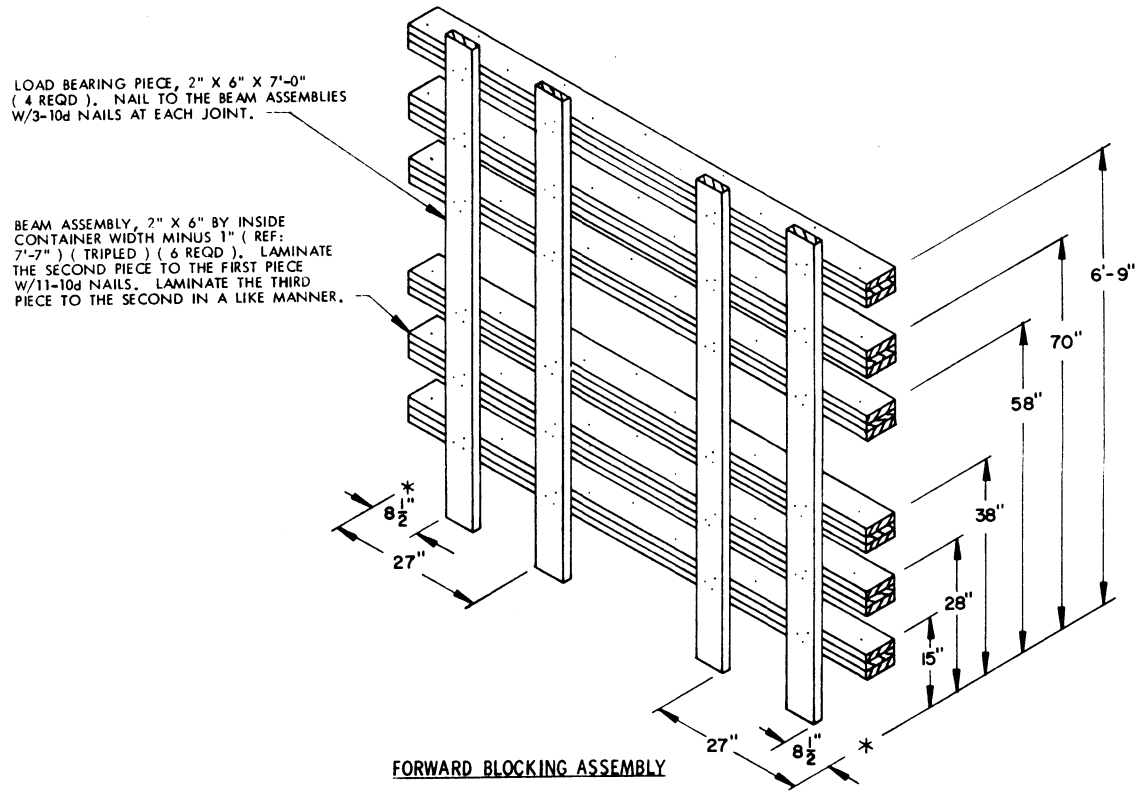

FORWARD BLOCKING ASSEMBLY

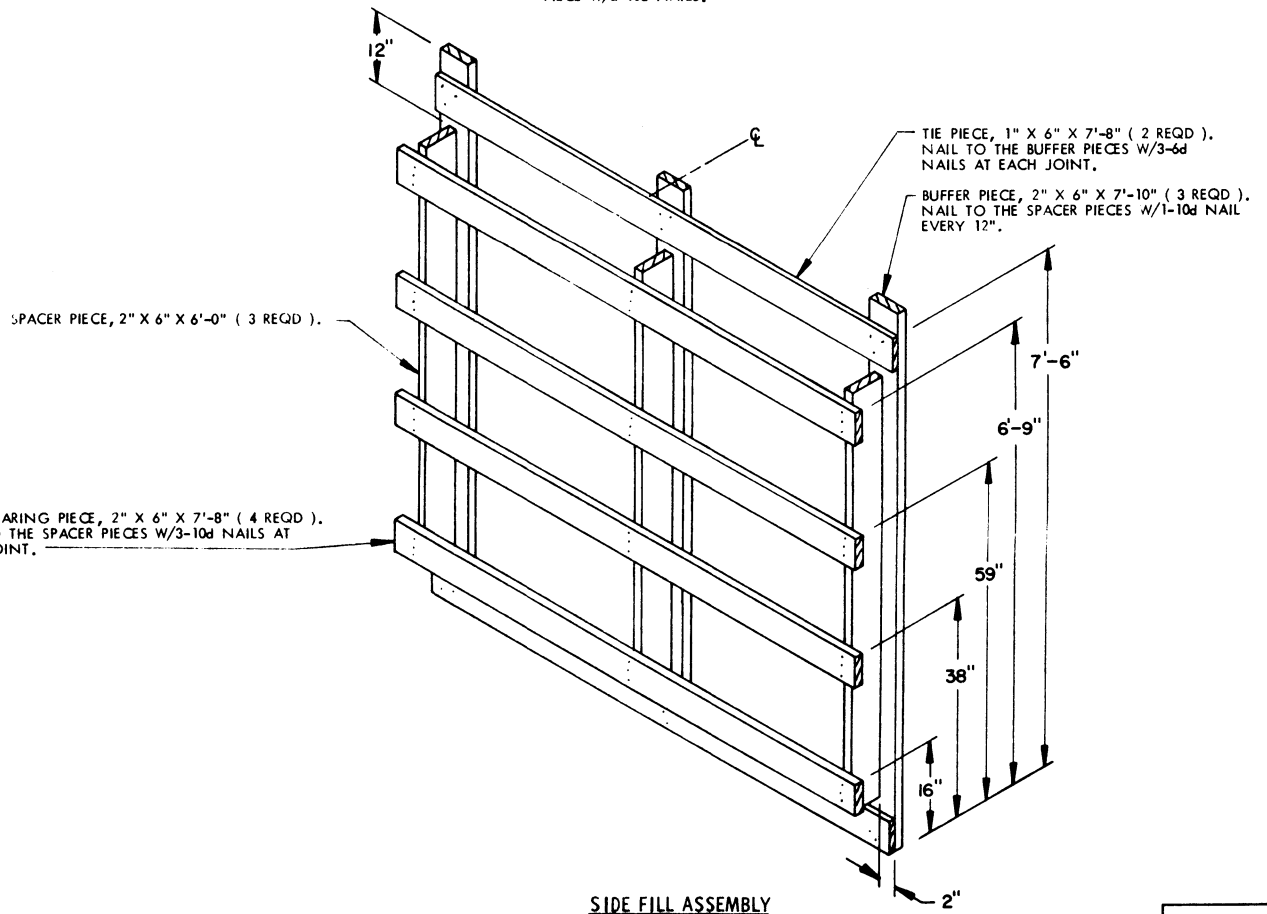
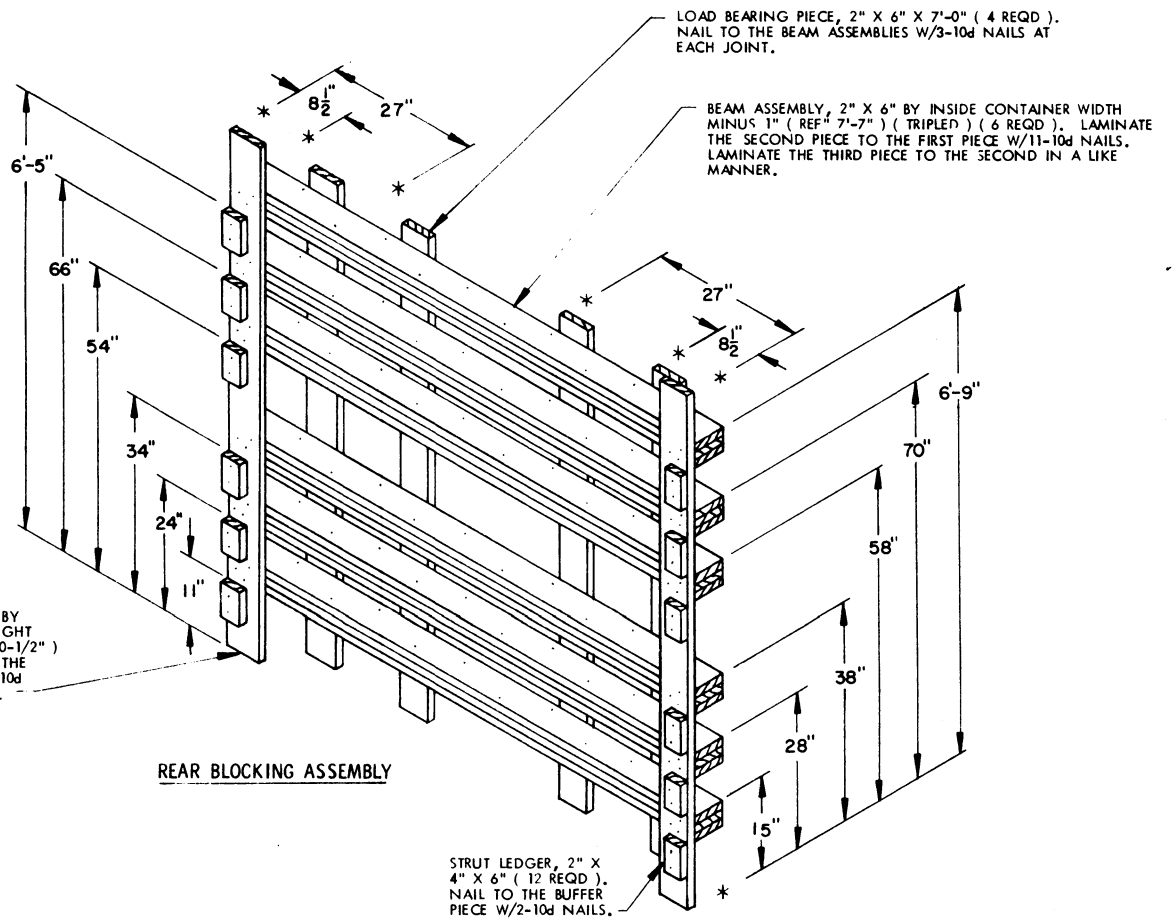

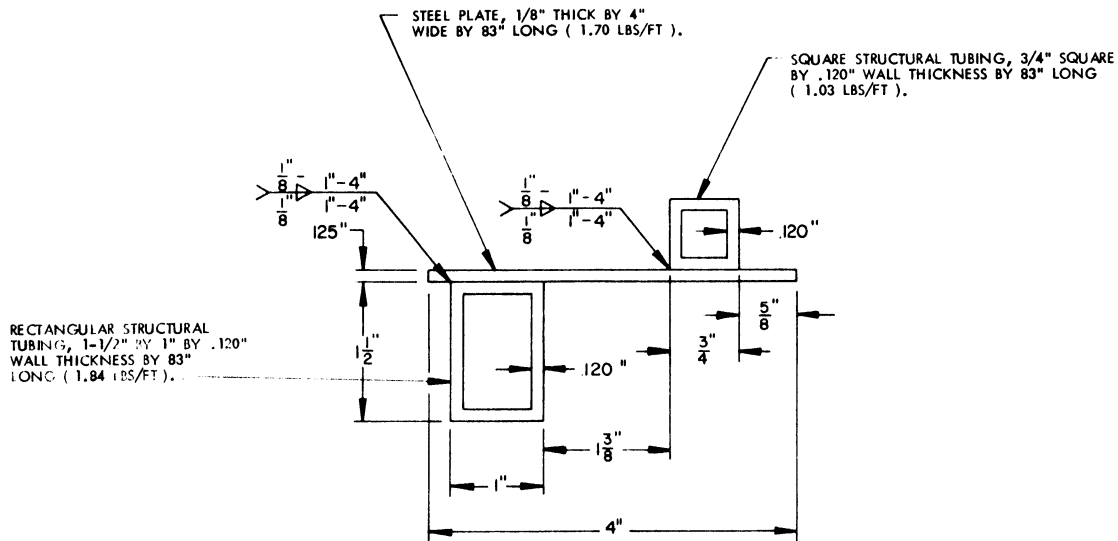

VIEW A

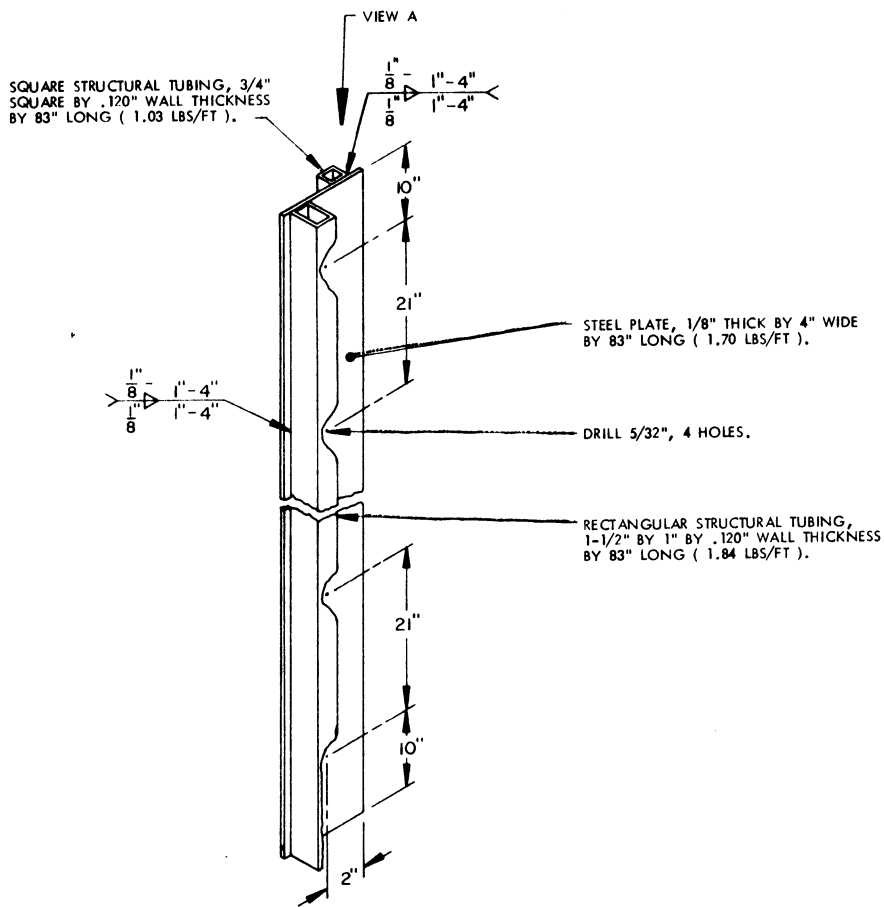

DOOR POST VERTICAL RETAINER

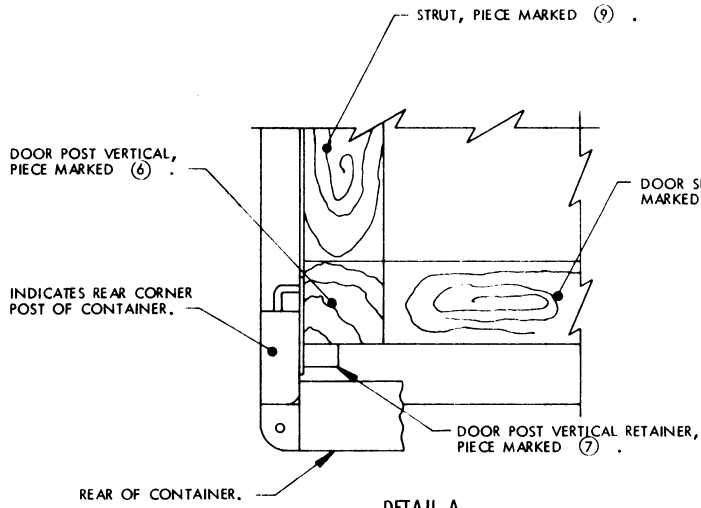

DETAIL A

A PARTIAL PLAN VIEW OF THE LEFT REAR PORTION OF THE CONTAINER IS SHOWN DEPICTING THE PROPER POSITION OF THE DOOR POST VERTICAL AND ADJACENT DUNNAGE PIECES.

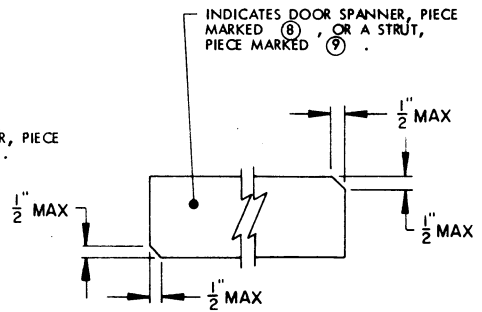

BEVEL-CUT

IF DESIRED, EACH END OF A DOOR SPANNER PIECE OR A STRUT MAY BE BEVEL-CUT AS SHOWN ABOVE TO FACILITATE THE ACHIEVEMENT OF A TIGHT DOOR-POST-TO-DOOR-POST FIT OR TIGHT REAR-OF-LOAD FIT.

VERTICAL PIECE, 4" X 4" BY INSIDE CONTAINER HEIGHT MINUS 1/2" (REF: 7'-10-1/2") (1 REQD).

STRUT LEDGER, 2" X 4" X 6" (12 REQD). NAIL TO THE VERTICAL PIECE W/2-10d NAILS.

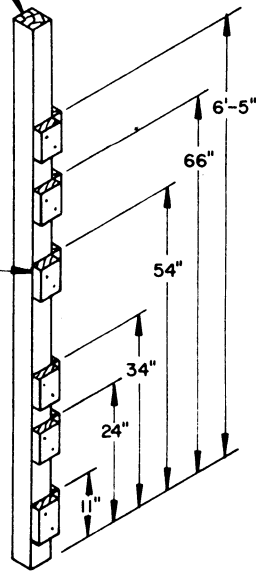

DOOR POST VERTICAL

THE STRUT LEDGERS CAN ONLY BE PRE-NAILED TO THE DOOR POST VERTICAL ON ONE SIDE OF THE CONTAINER FOR THE DOOR SPANNER PIECES. ALSO, THE STRUT LEDGERS FOR THE STRUTS CAN ONLY BE PRE-NAILED TO THE REAR BLOCKING ASSEMBLY OR THE DOOR POST VERTICAL AT THE LOWEST DIMENSION.

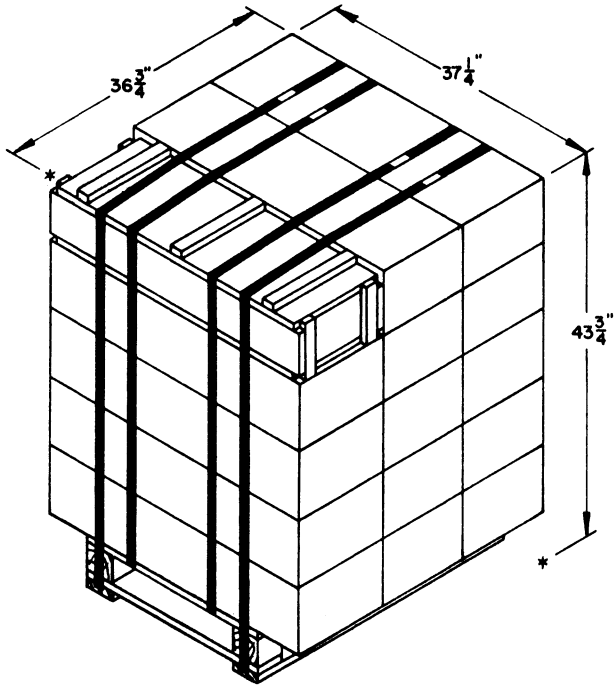

SKIDDED UNIT

UNIT WEIGHT ----- : 1,690 POUNDS (APPROX).
 CUBE ----- : 34.7 CUBIC FEET

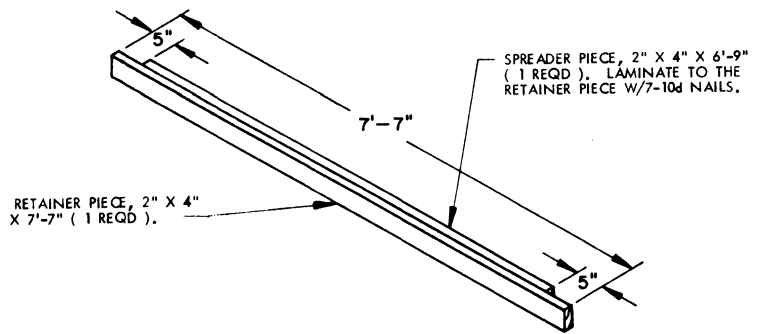

SPREADER ASSEMBLY