

APPROVED BY
 U. S. COAST GUARD (CG)
 NOTE: CONTAINERS OF PROPELLING CHARGES, CG CLASS 11-A, ARE AUTHORIZED BY TITLE 46 CFR (PARAGRAPH 146.29-42) FOR TRANSPORT BY WATER CARRIER WITHOUT THE SPECIFIC APPROVAL OF THE COAST GUARD.

APPROVED BY
 BUREAU OF EXPLOSIVES
A. J. Grossmuck
 SUPERVISOR, MILITARY & INTERMODAL SERVICES
 DATE *11/13/75*

LOADING AND BRACING[⊙] IN MILVAN CONTAINERS[⊕] OF PALLETIZED UNITS OF PROPELLING CHARGE PACKED IN THE PA66 SERIES CYLINDRICAL METAL CONTAINER (MIXED LOAD OF 20-CONTAINER AND 10-CONTAINER PALLET UNITS)

- ⊙ LOADING AND BRACING SPECIFICATIONS SET FORTH WITHIN THIS DRAWING ARE APPLICABLE TO LOADS THAT ARE TO BE SHIPPED BY TRAILER/CONTAINER-ON-FLAT-CAR (T/COFC) RAIL CARRIER SERVICE. THESE SPECIFICATIONS MAY ALSO BE USED FOR LOADS THAT ARE TO BE MOVED BY MOTOR OR WATER OR AIR CARRIERS. SEE "SPECIAL T/COFC NOTES" BELOW.
- ⊕ ONLY MILVAN CONTAINERS WHICH HAVE BEEN MODIFIED TO INCLUDE A MECHANICAL LOAD-BRACING SYSTEM THAT SATISFIES THE REQUIREMENTS OF THE BUREAU OF EXPLOSIVES PAMPHLET 6C WILL BE USED FOR THE MOVEMENT OF AMMUNITION BY T/COFC SERVICE. CAUTION: OTHER REQUIREMENTS OF PAMPHLET 6C ALSO APPLY.

NOTICE:
 US ARMY MATERIEL COMMAND DRAWING NO. 19-48-4106-15PM1001 ALSO SPECIFIES OUTLOADING PROCEDURES APPLICABLE TO SHIPMENT BY T/COFC OF PALLETIZED UNITS OF PROPELLING CHARGES IN MILVAN CONTAINERS. HOWEVER, THAT DRAWING DEPICTS MILVAN CONTAINERS WITH EITHER STANDARD PALLET UNITS OR MODIFIED PALLET UNITS. THIS DRAWING (D-SARAC-4373) DEPICTS A MIXED LOAD OF THE STANDARD 20-CONTAINER PALLET UNIT AND THE MODIFIED 10-CONTAINER PALLET UNIT IN THE SAME LOAD. BOTH DRAWINGS ARE APPROVED FOR USE, WITH DRAWING SELECTION THE PREROGATIVE OF THE SHIPPER.

MAXIMUM LOAD WEIGHT CRITERIA:

THE ITEMIZED LOAD WEIGHTS ARE CONTROLLED BY EQUIPMENT CAPABILITY FACTORS. ALSO, THESE LISTED LOAD WEIGHTS IDENTIFY THE MAXIMUM COMBINED WEIGHT OF AMMUNITION LADING UNITS AND DUNNAGE THAT CAN BE PLACED INTO ONE (1) MILVAN CONTAINER WITHOUT VIOLATING ONE OR MORE OF THE "CAPABILITY FACTORS". SEE NOTES 1 AND 2.

- 39,100 LBS IN 20-FT CONTAINERS (W/O CHASSIS) ABOARD CONTAINERSHIP.
- 39,100 LBS IN CONTAINER ON 20-FT CHASSIS WITH DOUBLE BOGIE. SEE NOTE 3.
- 25,300 LBS IN CONTAINER ON 20-FT CHASSIS WITH SINGLE BOGIE. SEE NOTE 4.
- 21,300 LBS IN EACH CONTAINER ON 40-FT CHASSIS (COUPLED WITH DOUBLE BOGIE). SEE NOTE 3.
- 19,300 LBS IN 20-FT CONTAINER (W/O CHASSIS) ABOARD FIXED-WING AIRCRAFT.
- 39,100 LBS IN 20-FT CONTAINER (W/O CHASSIS) FOR ROTARY-WING AIRCRAFT. SEE NOTE 5.

NOTE 1: DUNNAGE INCLUDES MATERIALS, OTHER THAN COMPONENTS OF THE MECHANICAL LOAD-BRACING SYSTEM, USED TO BLOCK AND BRACE A LOAD.

NOTE 2: ALTHOUGH THE HEAVIEST MAXIMUM LOAD IS DELINEATED ON PAGES 2 AND 3, PROVISIONS ARE INCLUDED WITHIN THIS DRAWING SO THAT THE BASIC LOAD CAN BE ADJUSTED TO SATISFY A LESSER QUANTITY OF LADING UNITS. ADDITIONAL INSTRUCTIONS ARE UNDER THE "REDUCED-LOAD PROVISIONS" SECTION ON PAGE 2.

NOTE 3: DEPENDING ON TRANSPORTATION ROUTING, IT MAY BE NECESSARY TO REDUCE THE LOAD WEIGHT TO SATISFY "WEIGHT LAWS" OF CERTAIN STATES. ALSO, IT MAY BE NECESSARY TO REDUCE THE LOAD WEIGHT TO SATISFY OTHER WEIGHT RESTRICTIONS IMPOSED ON THE MILVAN SYSTEM.

NOTE 4: BY SPECIAL AUTHORITY, IT MAY BE POSSIBLE TO MOVE HEAVIER LOADS ON SINGLE BOGIE CHASSIS WITHIN AN INSTALLATION.

NOTE 5: IT WILL BE NECESSARY TO REDUCE WEIGHT OF SOME LOADS TO BE MOVED BY ROTARY-WING AIRCRAFT, DEPENDING ON "LIFT" CAPABILITY OF THE SCHEDULED AIRCRAFT.

SPECIAL T/COFC NOTES:

- A. CAUTION: LOADED CONTAINERS MUST BE ON CHASSIS EQUIPPED WITH TWO BOGIE ASSEMBLIES WHEN BEING MOVED IN TOFC SERVICE, REGARDLESS OF LOAD WEIGHT WITHIN THE CONTAINER.
- B. LOAD LIMITS OF T/COFC RAIL CARS MUST NOT BE EXCEEDED, NOR WILL A CAR BE LOADED SO THAT THE TRUCK UNDER ONE END OF THE CAR CARRIES MORE THAN ONE-HALF OF THE LOAD LIMIT FOR THAT CAR.
- C. CHASSIS/CONTAINERS COUPLED INTO A 40-FOOT TRAILER CONFIGURATION MUST BE PLACED AT THE B-END OF A TOFC RAIL CAR. THE REAR END OF THE 40-FOOT UNIT WILL OVER-HANG THE END OF THE CAR IF IT IS PLACED AT THE A-END. TWENTY-FOOT AND 40-FOOT UNITS CAN BE LOADED ON THE SAME CAR.

DO NOT SCALE

REVISIONS		DRAFTSMAN <i>BL</i>	PROJ ENG <i>RHR/ANW</i>
		CHECKER <i>KS</i>	LOG ENGINE OFFICE <i>John Boyd</i>
		APPROVED <i>Paul Oswald</i> U. S. ARMY MATERIEL COMMAND	
		<i>W. E. Ehinger</i> U. S. ARMY MATERIEL COMMAND	
		USAMC AMMO CENTER	
		U. S. ARMY MATERIEL COMMAND	
		DATE: SEPTEMBER 1975	
		AMC AMMO CEN DWG NO	
		D-SARAC-4373	

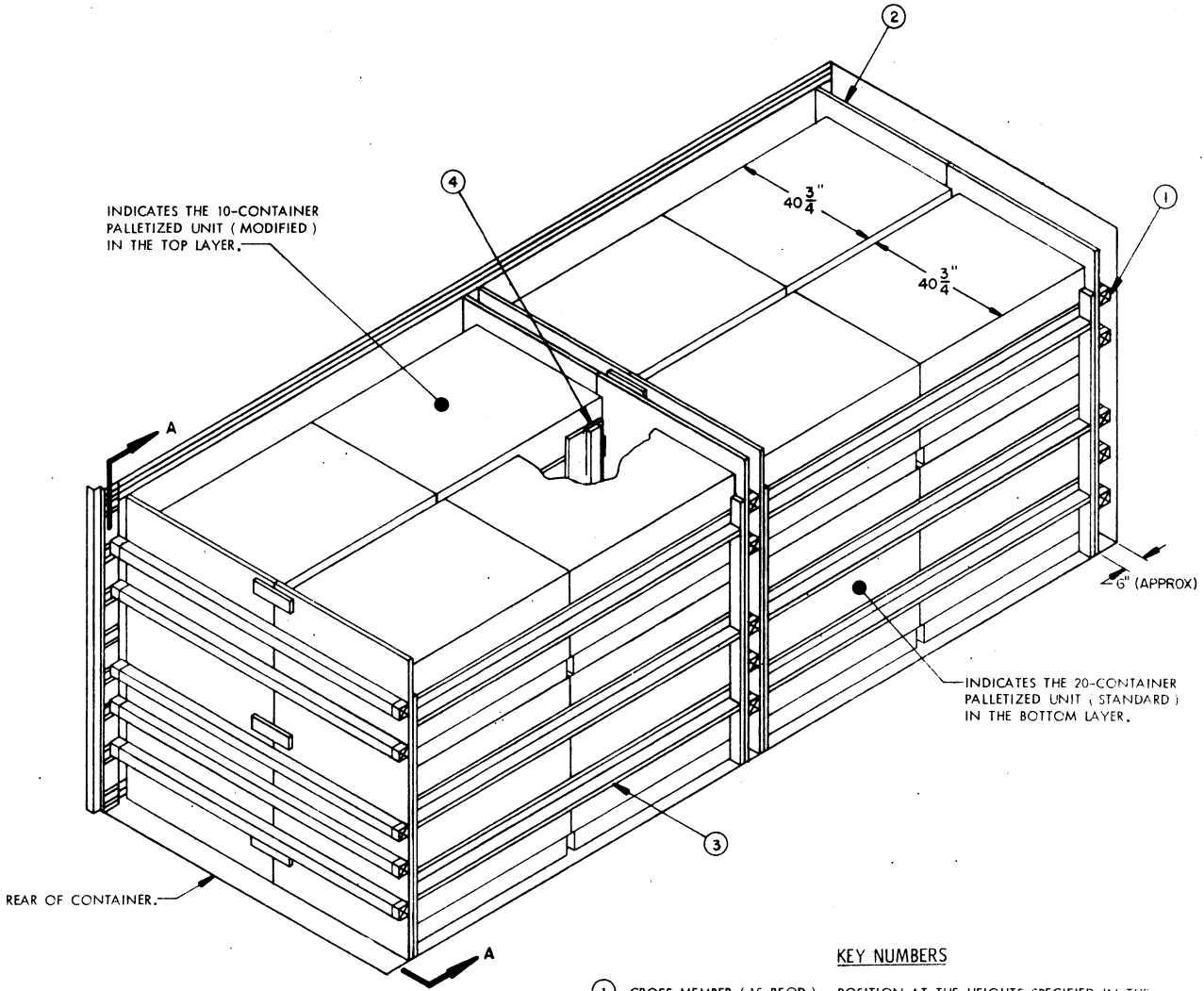

ISOMETRIC VIEW

KEY NUMBERS

- ① CROSS MEMBER (15 REQD). POSITION AT THE HEIGHTS SPECIFIED IN THE "SECTION A-A" VIEW. SEE THE "FILL DETAIL" ON PAGE 3.
- ② LOAD BEARING GATE (4 REQD). SEE THE "LOAD-BEARING GATE" DETAIL ON PAGE 4.
- ③ SIDE FILL GATE (4 REQD). SEE THE "SIDE FILL GATE" DETAIL ON PAGE 4. WIRE TIE THE SIDE FILL GATE TO THE BELT RAILS WITH TWO PIECES OF NO. 14 GAGE WIRE 18" LONG.
- ④ CENTER FILL GATE (4 REQD). SEE THE "CENTER FILL GATE" DETAIL ON PAGE 4. SEE GENERAL NOTE "G" ON PAGE 3.

REDUCED-LOAD PROVISIONS

WHEN A CONTAINER IS TO BE LOADED WITH A REDUCED QUANTITY OF LADING UNITS, THE LENGTHWISE CENTER OF GRAVITY OF A LOAD MUST BE WITHIN 12", IN EITHER DIRECTION, OF THE MIDPOINT IN A MILVAN, AND THE FOLLOWING CRITERIA WILL APPLY:

- A. IF A LOAD IS REDUCED BY ONLY A SMALL AMOUNT, LADING UNITS NORMALLY MAY BE ELIMINATED FROM THE REAR OF THE LOAD. SEE US ARMY MATERIEL COMMAND DRAWING NO. 19-48-4106-15PM1001 FOR ADDITIONAL GUIDANCE.
- B. IF A LOAD IS REDUCED BY A LARGE AMOUNT, LADING UNITS SHOULD BE ELIMINATED AS REQUIRED AND THE TOTAL LOAD SHIFTED AS NECESSARY FORE OR AFT, TO ACHIEVE A SYMMETRICAL WEIGHT DISTRIBUTION. THE DEPICTED PROCEDURES WILL BE FOLLOWED AS CLOSELY AS POSSIBLE, MAKING ONLY THOSE ADJUSTMENTS TO THE DUNNAGE WHICH ARE REQUIRED TO ACCOMMODATE THE NUMBER OF UNITS TO BE SHIPPED.
- C. COMBINATIONS OF THE VARIOUS DEPICTED LOADING PATTERNS MAY BE USED TO SATISFY THE NUMBER OF UNITS TO BE SHIPPED. HOWEVER, EACH LOAD BAY WILL BE INDEPENDENTLY BLOCKED AS A SEPARATE LOAD BAY IN ACCORDANCE WITH THE DEPICTED PROCEDURES FOR THAT SPECIFIC LOADING PATTERN.

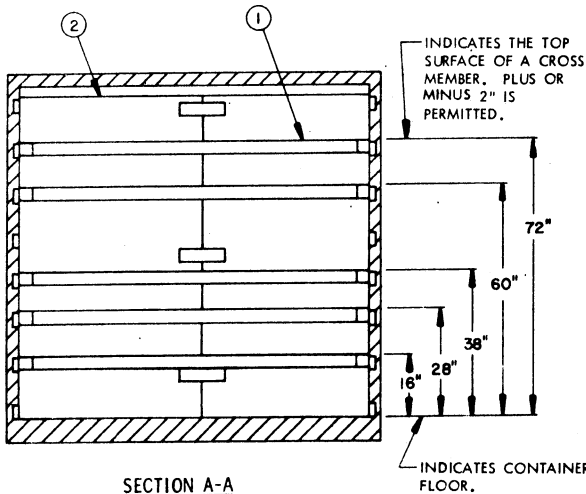

GENERAL NOTES

- A. THIS DOCUMENT HAS BEEN PREPARED AND ISSUED IN ACCORDANCE WITH AR 740-1, AND AUGMENTS TM 743-200-1 (CHAPTER 5).
- B. THE SPECIFIED OUTLOADING PROCEDURE IS APPLICABLE TO A MIXED LOAD OF 20-CONTAINER AND 10-CONTAINER PALLET UNITS OF PROPELLING CHARGE PACKED IN THE PA66 SERIES CYLINDRICAL METAL CONTAINER. SUBSEQUENT REFERENCE TO PALLET UNIT MEANS THE PALLETIZED UNIT WITH AMMUNITION ITEMS. SEE PAGES 5 AND 6 OF THIS DRAWING AND US ARMY MATERIEL COMMAND DRAWING NO. 19-48-4106-15PM1001 FOR DETAIL OF THE PALLETIZED UNIT. **CAUTION:** REGARDLESS OF THE QUANTITY OF UNITS TO BE SHIPPED, THE "MAXIMUM GROSS WEIGHT" OF 44,800 POUNDS MUST NOT BE EXCEEDED.
- C. THE LOAD AS SHOWN IS BASED ON A 20' LONG BY 8' WIDE BY 8' HIGH MILVAN CONTAINER WITH INSIDE DIMENSIONS OF 19'-4" LONG BY 92" WIDE BY 87" HIGH. THE LOAD IS DESIGNED FOR TRAILER/CONTAINER-ON-FLAT-CAR (T/COFC) SHIPMENT.
- D. THE SPECIFIED OUTLOADING PROCEDURES ARE FOR CONTAINERS EQUIPPED WITH SELF-CONTAINED MECHANICAL BRACING DEVICES AS DESCRIBED WITHIN BUREAU OF EXPLOSIVES PAMPHLET 6C. CROSS MEMBER ATTACHMENT FACILITIES WITHIN THESE CONTAINERS MUST PROVIDE FOR THE INSTALLATION OF LOAD BLOCKING CROSS MEMBERS AT THE HEIGHTS SPECIFIED. THE HEIGHT DIMENSIONS SPECIFIED WITHIN THIS DRAWING FOR THE INSTALLATION OF CROSS MEMBERS CONFORM WITH BUREAU OF EXPLOSIVES PAMPHLET 6C, WITH THE EXCEPTION THAT TWO (2) ADDITIONAL BELT-RAILS HAVE BEEN SHOWN, ONE AT 72" AND ONE AT 83" HEIGHT FROM THE CONTAINER FLOOR. VOIDS LENGTHWISE WITHIN THE LOAD MUST BE HELD TO A MINIMUM. CROSS MEMBERS MUST BE PLACED AGAINST THE LADING AS TIGHTLY AS THE HOLE SPACING IN THE CROSS MEMBER ATTACHMENT FACILITY PERMITS. EACH CROSS MEMBER WILL BE INSTALLED WITH THE ENDS ATTACHED AS NEARLY AS POSSIBLE IN "MATED" POSITIONS (AT EQUAL HEIGHTS, AND AT EQUAL DISTANCES FROM THE END OF THE CONTAINER). CROSS MEMBERS IN EMPTY CONTAINERS AND THOSE NOT USED IN LOADED CONTAINERS MUST BE FASTENED INTO BELT RAILS FOR SHIPMENT. COMPONENTS ASSIGNED TO EACH CONTAINER MUST REMAIN THEREWITH EVEN THOUGH UNUSED DURING SOME SHIPMENTS. SEE THE "FILL DETAIL" AT LEFT FOR THE DUNNAGING METHOD REQUIRED TO ELIMINATE AN EXCESSIVE LENGTHWISE VOID WITHIN A LOAD. THE LOAD BLOCKING COMPONENT DESIGNATED AS "CROSS MEMBER" HEREIN, IS IDENTIFIED AS "BEAM ASSEMBLY" WITHIN TM 55-8115-200-24, DATED SEPTEMBER 1972. THE BEAM ASSEMBLY IS FURTHER IDENTIFIED AS NSN 8115-00-165-6623 (FSN 8115-165-6623).
- E. DUNNAGE LUMBER SPECIFIED IS OF A NOMINAL SIZE. FOR EXAMPLE, 1" X 4" MATERIAL IS ACTUALLY 3/4" THICK BY 3-1/2" OR 3-5/8" WIDE AND 2" X 4" MATERIAL IS ACTUALLY 1-1/2" THICK BY 3-1/2" WIDE OR 1-5/8" THICK BY 3-5/8" WIDE.
- F. **CAUTION:** DO NOT NAIL DUNNAGE MATERIAL TO THE CONTAINER WALLS OR FLOOR. ALL NAILING WILL BE WITHIN THE DUNNAGE.
- G. ALTHOUGH A TOTAL OF 1-1/2" (ONE AND ONE-HALF INCHES) OF UNBLOCKED SPACE ACROSS THE WIDTH OF A LOAD BAY IS PERMITTED, LATERAL VOIDS WITHIN THE LOAD ARE TO BE HELD TO A MINIMUM. EXCESSIVE SLACK CAN BE ELIMINATED FROM A LOAD BAY BY LAMINATING ADDITIONAL BEARING PIECES OF APPROPRIATE THICKNESS TO THE BEARING PIECES OF THE CENTER FILL GATE. NAIL EACH ADDITIONAL PIECE TO THE BEARING PIECE W/1 APPROPRIATELY SIZED NAIL EVERY 12".
- H. A STAGGERED NAILING PATTERN WILL BE USED WHEREVER POSSIBLE WHEN NAILS ARE DRIVEN INTO JOINTS OF DUNNAGE ASSEMBLIES OR WHEN LAMINATING DUNNAGE. ADDITIONALLY, THE NAILING PATTERN FOR AN UPPER PIECE OF LAMINATED DUNNAGE WILL BE ADJUSTED AS REQUIRED SO THAT A NAIL FOR THAT PIECE WILL NOT BE DRIVEN THROUGH ONTO OR RIGHT BESIDE A NAIL IN A LOWER PIECE.
- J. PORTIONS OF THE CONTAINER DEPICTED WITHIN THIS DRAWING, SUCH AS ONE OF THE SIDEWALLS, HAVE NOT BEEN SHOWN IN THE LOAD VIEWS FOR CLARITY PURPOSES.

(CONTINUED AT LEFT)

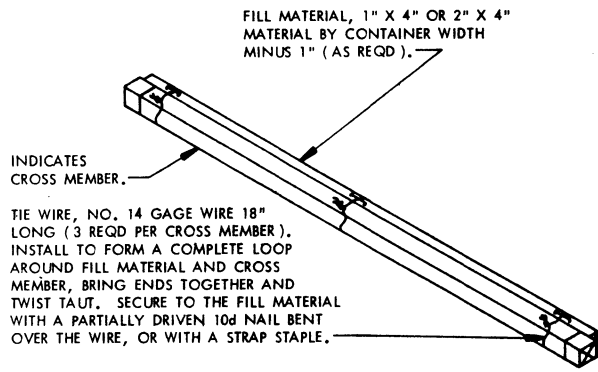

FILL DETAIL

THIS DETAIL DEPICTS METHOD OF POSITIONING FILL MATERIAL BETWEEN CROSS MEMBER AND LADING, WHEN THE VOID BETWEEN THE TWO IS GREATER THAN ONE INCH (1") FOR LONGITUDINAL BRACING.

(GENERAL NOTES CONTINUED)

- K. IF PLYWOOD IS NOT AVAILABLE OR IF DESIRED, THE LOAD BEARING GATES MAY BE FABRICATED FROM NOMINAL ONE-INCH AND TWO-INCH LUMBER. SEE THE "ALTERNATIVE LOAD BEARING GATE" DETAIL ON PAGE 4. RANDOM WIDTH MATERIAL MAY BE USED FOR THE SPECIFIED 1" THICK PIECES.

BILL OF MATERIAL		
LUMBER	LINEAR FEET	BOARD FEET
1" X 4"	12	4
1" X 6"	253	127
2" X 4"	188	126
NAILS	NO. REQD	POUNDS
6d (2")	476	3
10d (3")	48	3/4
PLYWOOD, 1/2" -----	210 SQ. FT. REQD -----	286 LBS
WIRE, NO. 14 GAGE -----	12' REQD -----	NIL
CROSS MEMBER -----		15 REQD

● THE BILL OF MATERIAL SHOWN IS APPLICABLE FOR ROUTED-DUNNAGE UNITS. IF THE UNITS ARE ASSEMBLED ON FLAT DUNNAGE, 255 LINEAR FEET OF 1" X 6" WILL BE REQUIRED IN LIEU OF 253, AND 190 LINEAR FEET OF 2" X 4" WILL BE REQUIRED IN LIEU OF 188.

MATERIAL SPECIFICATIONS

- LUMBER ----- : SEE TM 743-200-1, DUNNAGE LUMBER; FED SPEC MM-L-751.
- NAILS ----- : COMMON, CEMENT COATED OR CHEMICALLY ETCHED; FED SPEC FF-N-105. ALT: ANNULAR-RING TYPE NAIL OF THE SAME SIZE.
- WIRE ----- : FED SPEC QQ-W-461.
- STAPLE, STRAP --- : COMMERCIAL GRADE.
- PLYWOOD ----- : GROUP B OR C, GRADE C-D (EXTERIOR); FED SPEC NN-P-530. IF SPECIFIED GRADE IS NOT AVAILABLE, A BETTER EXTERIOR GRADE MAY BE SUBSTITUTED.

LOAD AS SHOWN (FLAT-DUNNAGE UNITS)

ITEM	QUANTITY	WEIGHT (APPROX)
20-CONTAINER PALLET UNIT -----	8 -----	13,552 LBS
10-CONTAINER PALLET UNIT -----	8 -----	7,248 LBS
DUNNAGE -----		938 LBS
CONTAINER -----		5,700 LBS
TOTAL GROSS WEIGHT -----		27,438 LBS

LOAD AS SHOWN (ROUTED-DUNNAGE UNITS) *

ITEM	QUANTITY	WEIGHT (APPROX)
20-CONTAINER PALLET UNIT -----	8 -----	13,560 LBS
10-CONTAINER PALLET UNIT -----	8 -----	7,256 LBS
DUNNAGE -----		933 LBS
CONTAINER -----		5,700 LBS
TOTAL GROSS WEIGHT -----		27,449 LBS

* LOAD SHOWN ON PAGE 2.

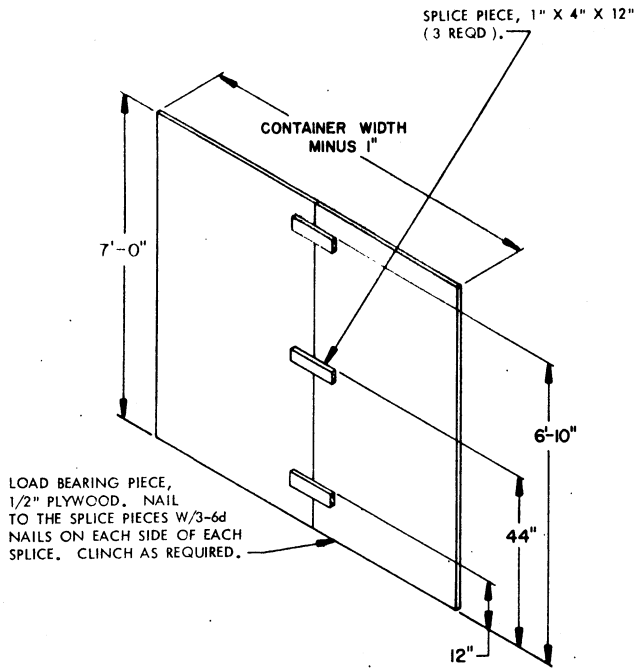

LOAD BEARING GATE

SEE GENERAL NOTE "K" ON PAGE 3.

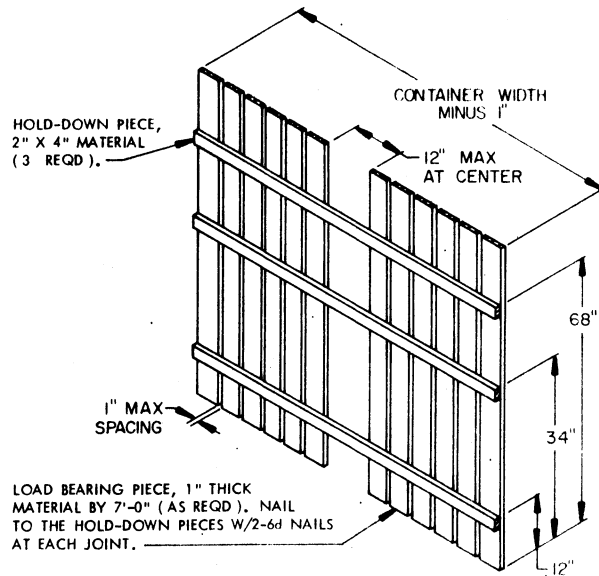

ALTERNATIVE LOAD BEARING GATE

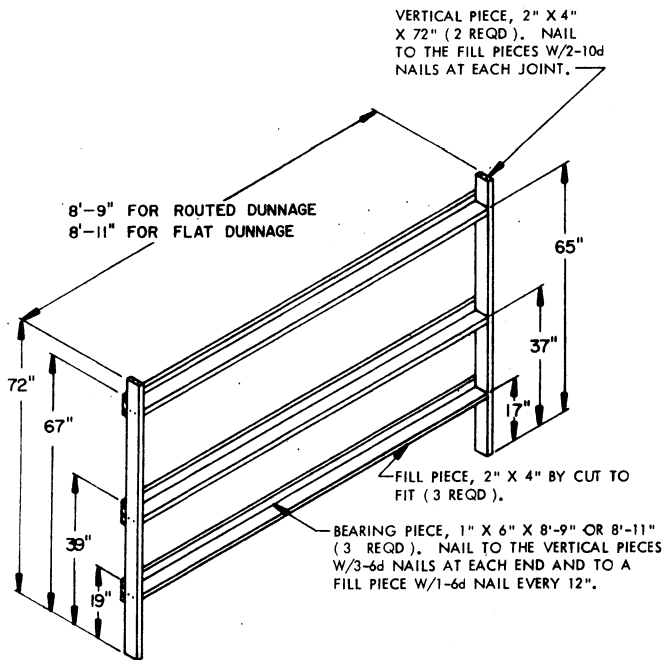

SIDE FILL GATE

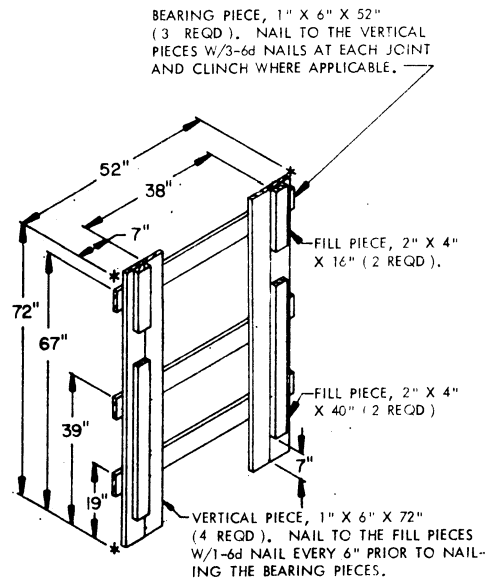

CENTER FILL GATE

SEE GENERAL NOTE "G" ON PAGE 3.

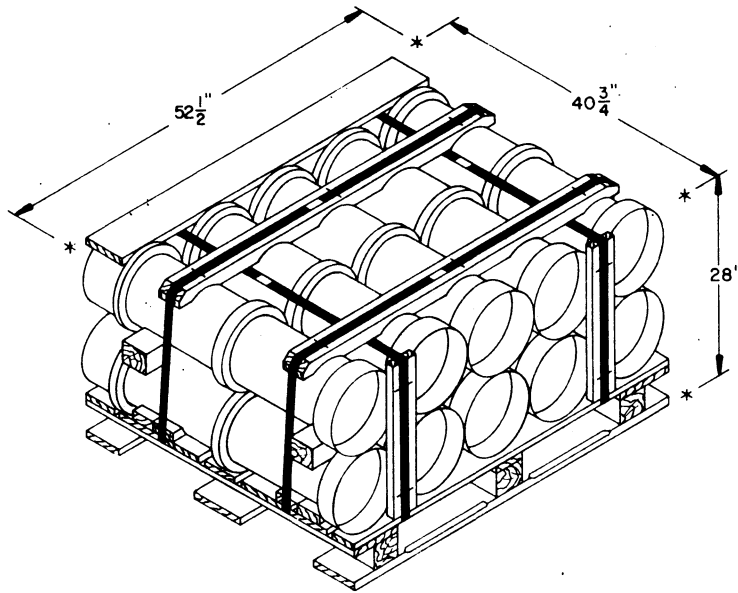

PALLET UNIT (MODIFIED)

ROUTED DUNNAGE

UNIT WEIGHT ----- 907 POUNDS (APPROX)
 CUBE ----- 34.7 CUBIC FEET.

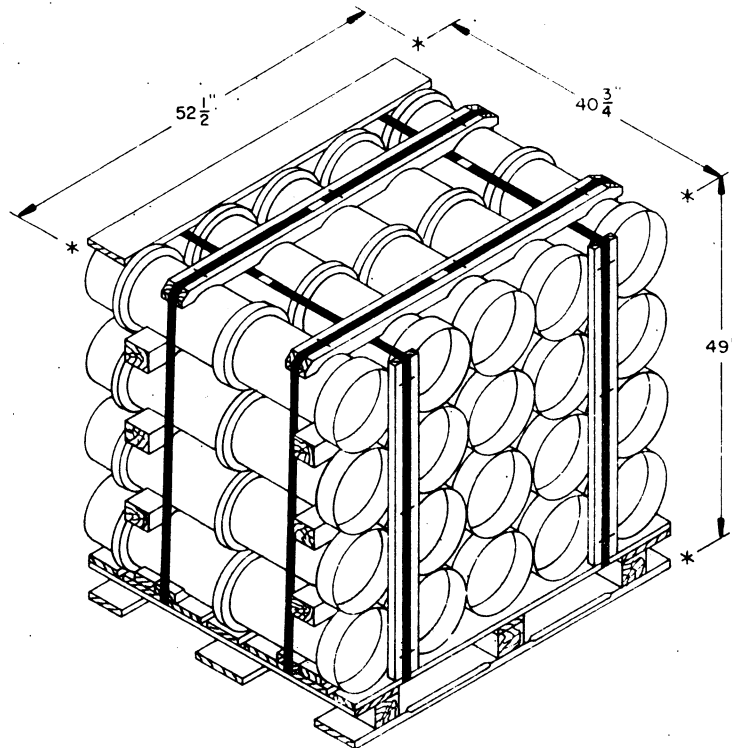

PALLET UNIT (STANDARD)

ROUTED DUNNAGE

UNIT WEIGHT ----- 1,695 POUNDS (APPROX).
 CUBE ----- 60.7 CUBIC FEET.

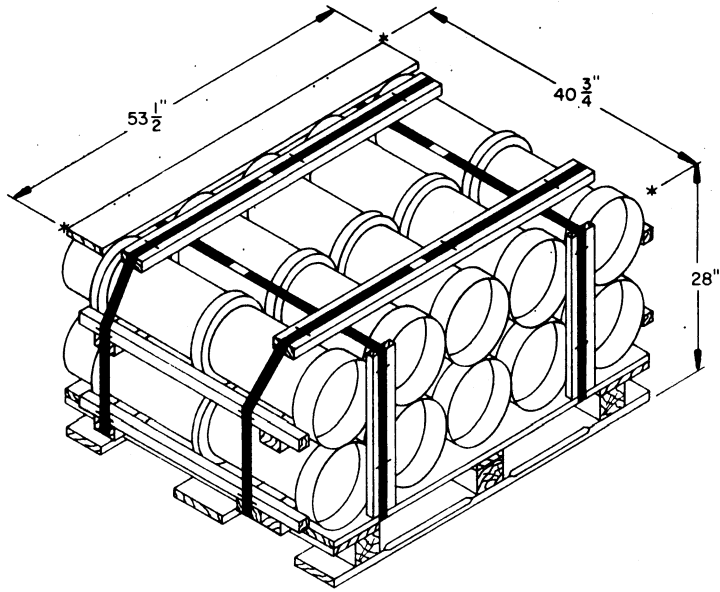

PALLET UNIT (MODIFIED)

FLAT DUNNAGE

UNIT WEIGHT ----- 906 POUNDS (APPROX).
 CUBE ----- 35.3 CUBIC FEET.

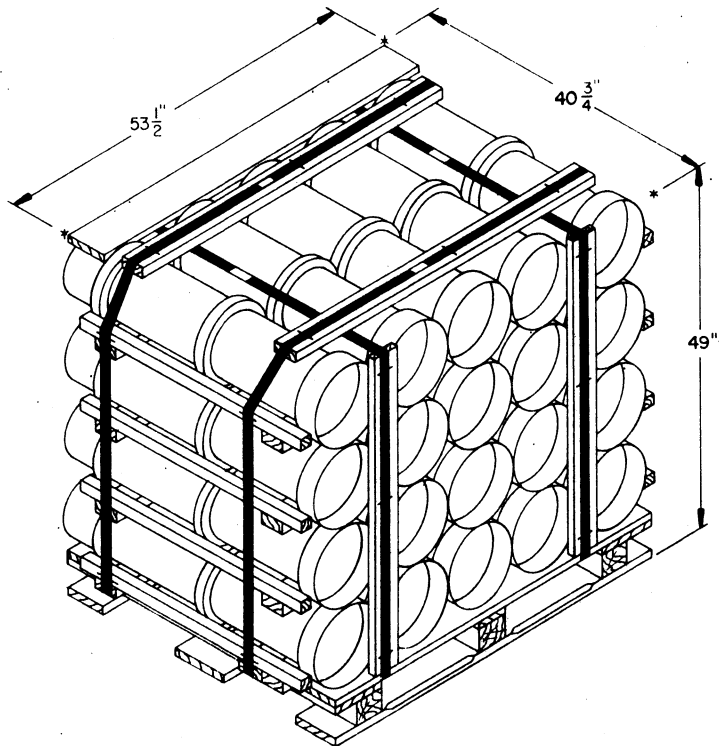

PALLET UNIT (STANDARD)

FLAT DUNNAGE

UNIT WEIGHT ----- 1,694 POUNDS (APPROX).
 CUBE ----- 61.8 CUBIC FEET.