

# METHOD 1 FOR 40-FOOT CARS

## FIXED-LOAD PROCEDURES FOR LOADING AND BRACING (CL) IN BOXCAR OF PALLETIZED EMPTY 105MM PROJECTILES<sup>●</sup> (M1 HE PROJ PACKED IAW PA PLT DWG 8837835)

● THE OUTLOADING PROCEDURES SPECIFIED WITHIN THIS DRAWING ARE ONLY APPLICABLE TO ITEMS WHICH ARE EMPTY. NOTICE: THE SPECIFIED LOADING AND BRACING PROCEDURES WILL NOT BE USED FOR SHIPPING ITEMS CONTAINING EXPLOSIVES.

**DO NOT SCALE**

REVISIONS			DRAFTSMAN	PROJ ENG
			<i>RSH</i>	<i>DIW/MS/CH</i>
			<i>RSH</i>	<i>John Boyd</i>
			APPROVED	
			<i>William G. Porter</i>	
			U. S. ARMY MUNITIONS COMMAND	
			APPROVED BY ORDER OF COMMANDING GENERAL	
			U. S. ARMY MATERIEL COMMAND	
			<i>W. E. King</i>	
			USAMC AMMO CENTER	
			U. S. ARMY MATERIEL COMMAND	
			DATE: MARCH 1973	
			AMC AMMO CEN DWG NO	
			<b>D-AMXAC-4330</b>	

PROJECT \_\_\_\_\_

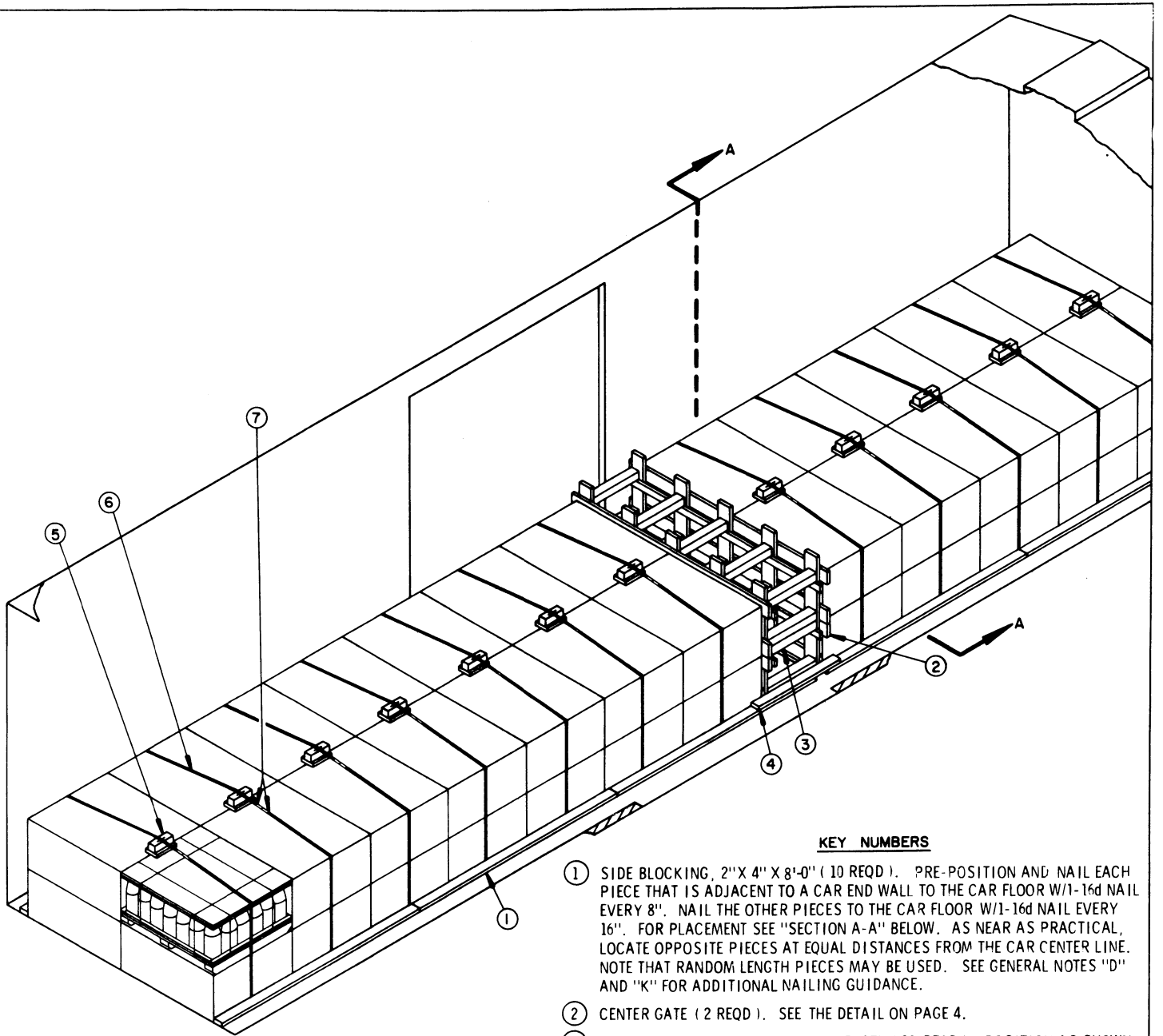

ISOMETRIC VIEW

**KEY NUMBERS**

- ① SIDE BLOCKING, 2" X 4" X 8'-0" ( 10 REQD ). PRE-POSITION AND NAIL EACH PIECE THAT IS ADJACENT TO A CAR END WALL TO THE CAR FLOOR W/1-16d NAIL EVERY 8". NAIL THE OTHER PIECES TO THE CAR FLOOR W/1-16d NAIL EVERY 16". FOR PLACEMENT SEE "SECTION A-A" BELOW. AS NEAR AS PRACTICAL, LOCATE OPPOSITE PIECES AT EQUAL DISTANCES FROM THE CAR CENTER LINE. NOTE THAT RANDOM LENGTH PIECES MAY BE USED. SEE GENERAL NOTES "D" AND "K" FOR ADDITIONAL NAILING GUIDANCE.
- ② CENTER GATE ( 2 REQD ). SEE THE DETAIL ON PAGE 4.
- ③ STRUT, 4" X 4" BY CUT-TO-FIT IN LENGTH ( 20 REQD ). POSITION AS SHOWN AND TOENAIL TO THE VERTICALS OF THE CENTER GATES W/2-16d NAILS AT EACH END. SEE THE "STRUT DETAIL" ON PAGE 4 AND GENERAL NOTE "F" FOR ADDITIONAL GUIDANCE.
- ④ GATE RETAINER, 2" X 4" X 48" ( 2 REQD ). NAIL TO PIECE MARKED ① W/3-10d NAILS AT EACH END.
- ⑤ STRAP PURCHASE BLOCK ( 12 REQD ). SEE THE DETAIL ON PAGE 4.
- ⑥ BUNDLING STRAP, 1-1/4" X .035" X 24'-0" LONG STEEL STRAPPING ( 12 REQD ). PRE-POSITION PRIOR TO LOADING A STACK SO THAT THE STRAP WILL ENCLOSE THE STACK AS SHOWN WHEN IT IS TENSIONED AND SEALED. SEAL EACH STRAP JOINT W/2-SEALS PER STRAP. STAPLE TO PIECE MARKED ⑤ W/1 STAPLE.
- ⑦ SEAL FOR 1-1/4" STEEL STRAPPING ( 24 REQD, 2 PER STRAP ). DOUBLE CRIMP EACH SEAL. SEE GENERAL NOTE "H".

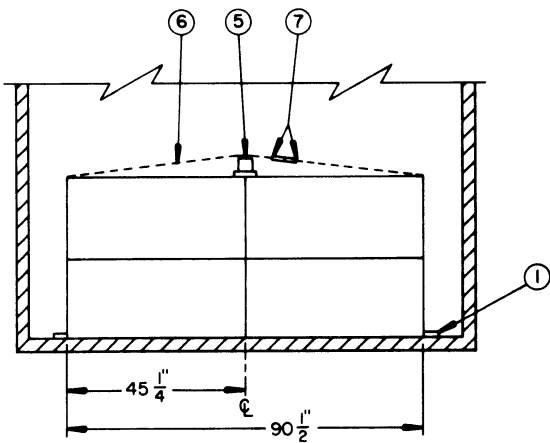

SECTION A-A

- J. DUNNAGE LUMBER SPECIFIED THROUGHOUT THIS PROCEDURAL DRAWING IS OF NOMINAL SIZE. FOR EXAMPLE, 2" X 4" MATERIAL IS ACTUALLY 1-1/2" THICK BY 3-1/2" WIDE OR 1-5/8" THICK BY 3-5/8" WIDE AND 4" X 4" MATERIAL IS ACTUALLY 3-1/2" THICK BY 3-1/2" WIDE OR 3-5/8" THICK BY 3-5/8" WIDE. IF 2" X 3" MATERIAL IS NOT AVAILABLE, TWO SUITABLE WIDTH PIECES CAN BE MADE BY "RIPPING" NOMINAL 2" X 6" MATERIAL. ALTHOUGH NOMINAL SIZE LUMBER IS SPECIFIED HEREIN, "ROUGH CUT" LUMBER OF EQUAL OR GREATER STRENGTH CAN BE SUBSTITUTED, PROVIDING NAIL SIZES ARE ADJUSTED ACCORDINGLY.
- K. A STAGGERED NAILING PATTERN WILL BE USED WHEREVER POSSIBLE WHEN NAILS ARE DRIVEN INTO JOINTS OF DUNNAGE ASSEMBLIES OR WHEN LAMINATING DUNNAGE. ADDITIONALLY, THE NAILING PATTERN FOR AN UPPER PIECE OF LAMINATED DUNNAGE WILL BE ADJUSTED AS REQUIRED SO THAT A NAIL FOR THAT PIECE WILL NOT BE DRIVEN THROUGH ONTO OR RIGHT BESIDE A NAIL IN A LOWER PIECE.
- L. PORTIONS OF THE DEPICTED CAR, SUCH AS A CAR SIDEWALL, HAVE BEEN OMITTED FROM THE LOAD VIEWS FOR CLARITY PURPOSES.
- M. NOTICE: IF AUTHORIZED BY THE U.S. ARMY MUNITIONS COMMAND, JOLIET, ILLINOIS, ON A CASE BY CASE BASIS, THE LOADING AND BRACING SPECIFICATIONS OF THIS DRAWING CAN ALSO BE USED FOR SHIPPING SOME OF THE OTHER PROJECTILES IDENTIFIED WITHIN PA DRAWING 8837835. HOWEVER, THE FOLLOWING CRITERIA WILL APPLY.
  1. ONLY EMPTY PROJECTILES ARE ACCEPTABLE. PROJECTILES CONTAINING EXPLOSIVE FILLER OR OTHER TYPES OF FILLER ARE NOT TO BE SHIPPED BY THE DELINEATED PROCEDURES.
  2. A PALLET UNIT OF PROJECTILES THAT WEIGHS MORE THAN 2,335 POUNDS IS NOT ACCEPTABLE. ALSO, A PALLET UNIT THAT HAS A DIFFERENT BASIC WIDTH AND/OR LENGTH FROM THE UNIT SHOWN HEREIN IS NOT ACCEPTABLE.
  3. FOR PALLET UNITS THAT ARE HIGHER THAN 21" OR LOWER THAN 20" IN HEIGHT, THE DUNNAGE GATES SPECIFIED IN THIS DRAWING MUST BE CHANGED TO SUIT. BASICALLY, THE LOCATIONS FOR THE HORIZONTAL MEMBERS ON THE GATES MUST BE ADJUSTED TO COMPENSATE FOR THE DIFFERENT LOAD HEIGHT. MODIFIED GATES MUST PROVIDE FOR THE SAME BLOCKING PRINCIPLES AS ARE PROVIDED BY THE DELINEATED GATES.

- A. THIS DOCUMENT HAS BEEN PREPARED AND ISSUED IN ACCORDANCE WITH AMCR 740-13.
- B. THE OUTLOADING PROCEDURES SPECIFIED IN THIS DRAWING ARE "INTERIM PROCEDURES" APPLICABLE TO THE OUTLOADING OF PALLETIZED EMPTY 105MM PROJECTILES. THIS DRAWING WILL BE USED UNTIL CANCELLED AND/OR SUPERSEDED BY A USAMC 19-48 SERIES DRAWING.
- C. PALLET UNIT DATA:  
 DIMENSIONS ( APPROX ) ----- 38" LONG X 45" WIDE X 20-1/2" HIGH.  
 GROSS WEIGHT ( APPROX ) ----- 2,323 POUNDS.
- D. THE 48-UNIT LOAD DEPICTED HEREIN IS BASED ON A 40'-6" LONG BY 9'-2" WIDE BOXCAR THAT HAS 8'-0" WIDE THROUGH DOORS OF THE CONVENTIONAL SLIDING TYPE AND HAS A LOAD LIMIT OF NOT LESS THAN 113,000 POUNDS. WHEN SHIPPING A 48-UNIT LOAD, A CAR THAT HAS A LOAD LIMIT LESS THAN 113,000 POUNDS MUST NOT BE USED. HOWEVER, ANY WIDTH CAR MAY BE USED, AND CARS WITH ANY TYPE OR WIDTH DOOR CAN BE USED, BUT TO FACILITATE LOADING OPERATIONS CARS THAT HAVE DOOR OPENINGS 8'-0" WIDE OR WIDER SHOULD BE USED. IF A CAR WITH PLUG DOORS IS USED, AFTER THE PLUG DOORS ON A CAR ARE CLOSED AND READY FOR THE INSTALLATION OF "CAR SEALS", A PIECE OF WIRE OF SUITABLE SIZE WILL BE USED IN ADDITION TO, AND IN CONJUNCTION WITH, EACH CAR SEAL USED TO "SEAL" THE CAR. THE WIRE WILL BE THREADED THROUGH THE HOLES IN THE DOOR LATCH ASSEMBLY ONE OR MORE TIMES, AND THE WIRE ENDS WILL BE TWISTED TOGETHER. ALSO, ALL-METAL CARS CAN BE USED. IF THE CAR BEING USED FOR THE SHIPMENT OF THE DEPICTED LOAD IS EQUIPPED WITH A NAILABLE METAL FLOOR AND A NAIL SIZE FOR FLOOR NAILING IS MARKED ON THE SIDEWALL OF THE CAR, THAT GUIDANCE SHOULD BE APPLIED TO THE NAILING OF THE APPLICABLE DUNNAGE PIECES. IF A NAIL SIZE IS NOT SPECIFIED IN THE CAR, 30d NAILS SHOULD BE USED. IF 30d NAILS CANNOT BE DRIVEN PROPERLY, THEN 20d NAILS SHOULD BE USED. NAILS OF A LESSER SIZE ARE NOT ACCEPTABLE.
- E. THE SELECTION OF RAIL CARS FOR THE TRANSPORT OF THE DESIGNATED ITEM IS THE RESPONSIBILITY OF THE SHIPPER. ONLY CARS WHICH HAVE "SOUND" FLOORS AND ARE IN OTHERWISE PROPER CONDITION TO SAFELY TRANSPORT THE LADING TO DESTINATION WITHOUT DAMAGE WILL BE SELECTED.
- F. PALLET UNITS ARE TO BE PLACED INTO A LOAD AS CLOSE TOGETHER AS POSSIBLE THROUGHOUT THE LENGTH OF THE LOAD BAYS TO ACHIEVE A "TIGHT" LOAD. IT IS RECOMMENDED THAT "LOAD JACKS" BE USED TO TIGHTEN A LOAD AFTER THE CENTER GATES HAVE BEEN POSITIONED AND PRIOR TO INSTALLING THE STRUTS. EXERCISE CAUTION WHEN USING LOAD JACKS SO AS TO NOT OVER TIGHTEN A LOAD AND DAMAGE THE PALLET UNITS. WHEN LOAD JACKS ARE NOT AVAILABLE, THE PROVISIONS OF THE "STRUT DETAIL" ON PAGE 4 CAN BE APPLIED TO AID IN ACHIEVING A "TIGHT" LOAD. STRUTS SHOULD BE CUT SLIGHTLY LONGER THAN THE "MEASURED DISTANCE" AND THEN DRIVEN INTO PLACE, THUS FORCING THE CENTER GATES AND LOAD BAYS APART.
- G. TO LOAD THE PALLET UNITS THAT EXTEND INTO THE DOORWAY AREA OF THE CAR, IT WILL BE NECESSARY TO HANDLE THE UNITS FROM A SIDE POSITION WITH THE TINES OF A FORKLIFT TRUCK UNDER THE 4 BY 4 SKIDS OF THE PALLET. AFTER A PALLET HAS BEEN LOCATED IN ITS APPROXIMATE SHIPPING POSITION IT WILL BE LOWERED TO REST ON THE FLOOR OF THE CAR OR A FIRST LAYER UNIT ON THE FAR SIDE OF THE CAR AND ON A SHORT 4 BY 4 BLOCK ON THE NEAR SIDE. THE BLOCK WILL FACILITATE WITHDRAWAL OF THE FORKLIFT TINES. THE FORKLIFT TINES WILL THEN BE PLACED UNDER THE EDGE OF THE PALLET COVER ASSEMBLY AND USED TO RAISE THE PALLET UNIT JUST ENOUGH TO ALLOW FOR THE REMOVAL OF THE 4 BY 4 BLOCK. AFTER THE PALLET UNIT HAS BEEN LOWERED, IT WILL BE INCHED INTO ITS SHIPPING POSITION. IF AVAILABLE CAPABILITY DOES NOT PERMIT "DOORWAY AREA" LOADING AS DESCRIBED ABOVE OR IF IT IS DESIRED, THE LOADING AND BRACING SPECIFICATIONS DELINEATED BY DRAWING D-AMXAC-4331 SHOULD BE USED IN LIEU OF THE SPECIFICATIONS SET FORTH BY THIS DRAWING.
- H. WHEN ANY STRAP IS SEALED AT AN END-OVER-END LAP JOINT, TWO ( 2 ) SEALS, BUTTED TOGETHER, WITH TWO ( 2 ) PAIR OF CRIMPS PER SEAL MUST BE USED TO SEAL THE JOINT. CAUTION: EXERCISE CARE DURING TENSIONING TO PREVENT DAMAGE TO THE PALLET UNITS.

BILL OF MATERIAL		
LUMBER	LINEAR FEET	BOARD FEET
2" X 2"	15	5
2" X 3"	37	19
2" X 4"	88	59
2" X 6"	112	112
4" X 4"	49	66
NAILS	NO. REQD	POUNDS
10d ( 3" )	36	3/4
16d ( 3-1/2" )	380	8-1/4
STEEL STRAPPING, 1-1/4" X 035" --- 288' REQD --- 41 LBS		
SEAL FOR 1-1/4" STRAPPING --- 24 REQD --- 1 LB		
STAPLE, 1-3/8" X 3/4" --- 12 REQD --- NIL		

**MATERIAL SPECIFICATIONS**

- LUMBER-----: SEE TM 743-200-1, DUNNAGE LUMBER; FED SPEC MM-L-751.
- NAILS-----: COMMON, CEMENT COATED OR CHEMICALLY ETCHED, FED SPEC FF-N-105.  
ALT: ANNULAR-RING TYPE NAIL OF THE SAME SIZE.
- STRAPPING, STEEL: TYPE I OR IV, CLASS A, B, OR C; FED SPEC QQ-S-781
- STAPLE, STRAP; SEAL, STRAP ----: COMMERCIAL GRADE.

( CONTINUED AT UPPER LEFT )

**LOAD AS SHOWN**

ITEM	QUANTITY	WEIGHT (APPROX)
PALLET UNIT-----	48	111,504 LBS
DUNNAGE-----		702 LBS
TOTAL WEIGHT-----		112,206 LBS

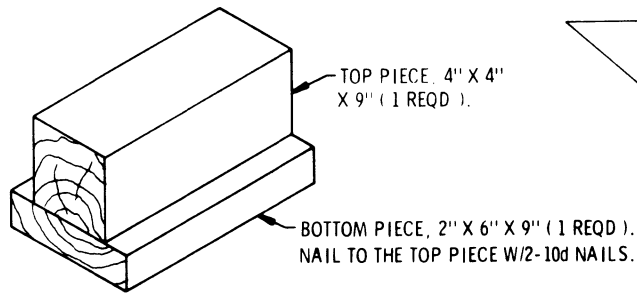
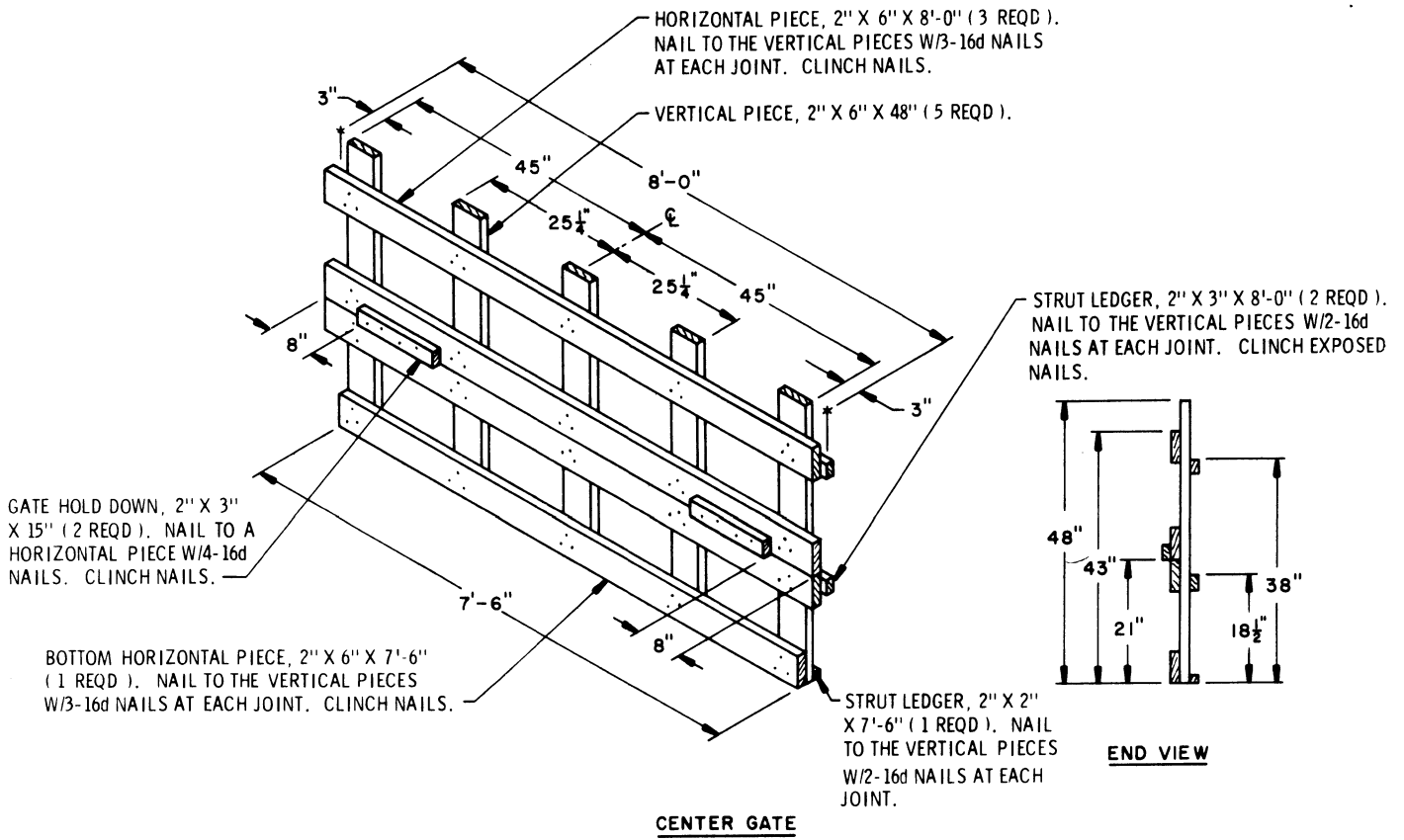

**STRAP PURCHASE BLOCK**

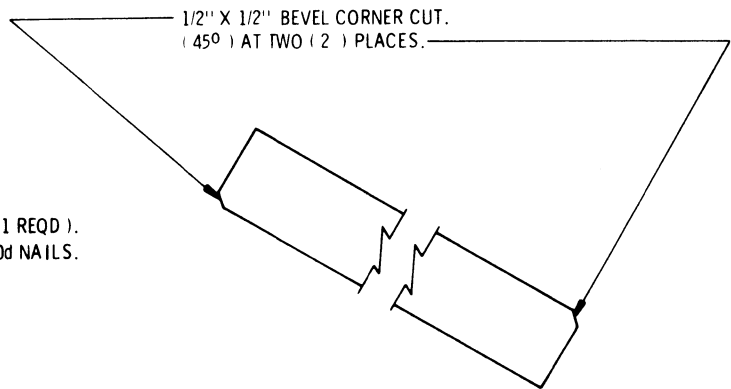

**STRUT DETAIL**

BEVEL CUTS SHOWN ARE REQUIRED TO FACILITATE A TIGHT WEDGE FIT. THE BEVEL CUT PROVISIONS ARE OPTIONAL, BUT THEY ARE RECOMMENDED IF "LOAD JACKS" ARE NOT AVAILABLE TO TIGHTEN A LOAD IN ACCORDANCE WITH GUIDANCE SET FORTH BY GENERAL NOTE "F" ON PAGE 3.