

NOTE:

- TOTAL UNIT LOAD WEIGHT NOT TO EXCEED 1500 LBS.

		REVISION		
LTR	DESCRIPTION	DATE	APPROVED	
-	PRODUCT BASELINE ERR RBT2002	97-11-04	97-11-04	BARTOSIAK
A	ECP ROK3003	00-07-25	00-08-22	

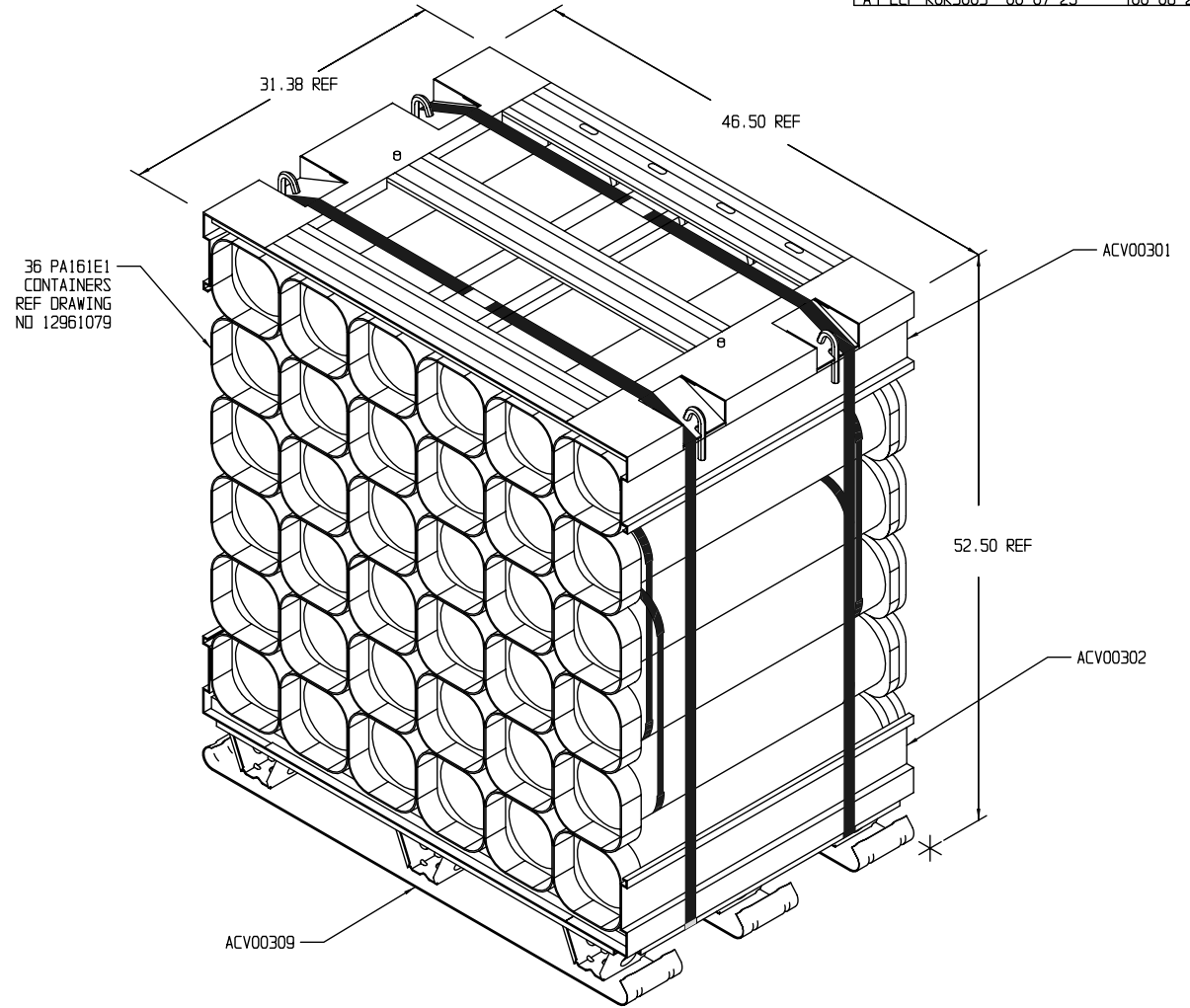

COMBINATION OF ADOPTED ITEMS	PART NO
PALLET - SPECIAL SIZE 46.50 X 31.38 SHEET METAL	ACV00309
TOP ASSEMBLY - PALLET ADAPTER PA161E1 CONTAINER	ACV00301
BOTTOM ASSEMBLY - PALLET ADAPTER PA161E1 CONTAINER	ACV00302
UNITIZATION DRAWING (ARMY)	19-48-4231/50- 20PM1006

PART NO SEE TABLE

DISTRIBUTION STATEMENT A.

APPROVED FOR PUBLIC RELEASE;  
DISTRIBUTION IS UNLIMITED.

UNLESS OTHERWISE NOTED DIMENSIONS ARE IN INCHES. BREAK SHARP CORNERS AND EDGES.		DATE 97-11-04	DESIGN ACTIVITY U.S. ARMY OPERATIONS SUPPORT COMMAND DEFENSE AMMUNITION CENTER MCALISTER, OKLAHOMA 74501-9053
TOLERANCES ON FRACTIONS DECIMALS	± .06	OPTION MSB	CHIEF SMS BARTOSIAK
MATERIAL		DESIGN-ORIG JHK/EJA	T. J. MICHELS CHIEF, SUPPLY ENGINEERING DIV
MACS		SUBMITTED BY WILLIAM F. ERNST CHIEF, LOGISTICS ENGINEERING OFFICE	COMBINATION OF ADOPTED ITEMS, PALLET & PALLET ADAPTER, UNITIZATION OF PA161E1 CONTAINER
NEXT ASSY	USED ON	APPROVED BY ORDER OF COMMANDING GENERAL, U.S. ARMY MATERIEL COMMAND (AMC) ARTHUR J. PODSIADLO	SIZE D
APPLICATION		U.S. ARMY DEFENSE AMMUNITION CENTER	CAGE CODE 28620
			SCALE 1/5
			UNIT WT
			SHEET 1 OF 1