

Code Ident.
10001

Naval Sea Systems Command
Department of the Navy

WR-54/215B
Change Notice 1
1 May 1986

Weapons Requirement Palletizing

Fleet Issue Unit Load

Dispenser and Bomb, Aircraft, CBU-59B, Complete (APAM) or

Dispenser and Bomb, Aircraft, CBU (T-1)/B, Training

In Container, Mk 427 Mod 0

Make the following pen and ink change:

Page 1.

Hazard Classification. "Change the CG Hazard Class of E820 from
X-B to VII."

AMSC No. - N/A

DISTRIBUTION STATEMENT A

Approved for public release;
distribution is unlimited.

Distribution
FSC 8140

Preparing Activity
NWHC, NWS Earle

Code Ident
10001

Naval Sea Systems Command
Department of the Navy

WR-54/215B

19 SEPTEMBER 1975
SUPERSEDING WR-54/215A
22 FEBRUARY 1974

**WEAPONS REQUIREMENT, PALLETIZING
FLEET ISSUE UNIT LOAD
DISPENSER AND BOMB, AIRCRAFT, CBU-59/B, COMPLETE (APAM)
OR
DISPENSER AND BOMB, AIRCRAFT, CBU(T-1)/B, TRAINING
IN CONTAINER, MK 427 MOD 0**

UNIT LOAD DATA

NUMBER OF ITEMS PER CONTAINER 1
 NUMBER OF CONTAINERS PER UNIT LOAD 2
 NUMBER OF ITEMS PER UNIT LOAD 2
 GROSS WEIGHT OF ONE CONTAINER (APPROX.) 1143 LBS
 GROSS WEIGHT OF UNIT LOAD (APPROX.) 2295 LBS Δ
 CUBE 71.4 CU FT

DO NOT STACK MORE THAN
6 UNIT LOADS HIGH IN STORAGE Δ DO NOT USE FOR SHIPPING PURPOSES

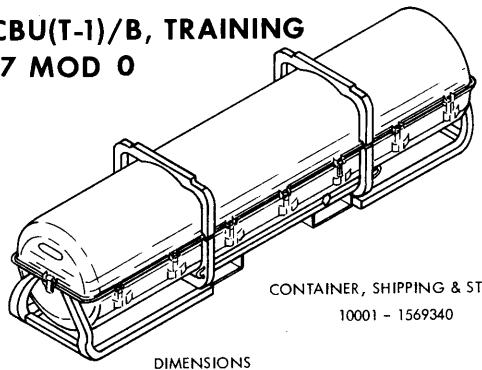

CONTAINER, SHIPPING & STORAGE
10001 - 1569340

DIMENSIONS

LENGTH 102 17/32
 WIDTH 23 5/32
 HEIGHT (OVERALL) 25 31/32
 (STACKING) 25 17/32

HAZARD CLASSIFICATION

DODIC/ NALC NO.	DISPENSER	HAZARD CLASS	
		DOT	CG
E820	CBU-59/B COMPLETE	A	X-B
NONE	CBU-59(T-1)/B TRAINING	C	I

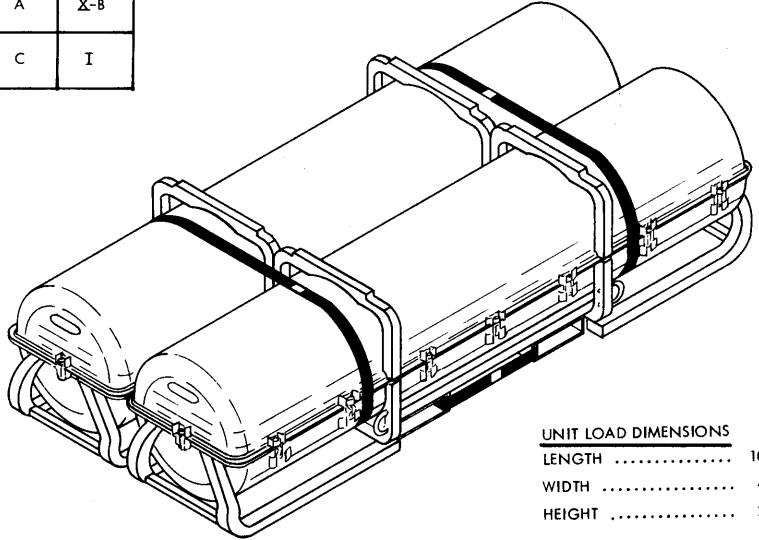

UNIT LOAD DIMENSIONS

LENGTH 102 17/32
 WIDTH 46 5/16
 HEIGHT 25 31/32

FOR GENERAL PALLETIZING
REQUIREMENTS SEE WR-54

UNLESS OTHERWISE SPECIFIED
DIMENSIONS ARE IN INCHES

WR NO.	ASSOCIATED PROCESS	REV LTR	REVISION DESCRIPTION	DATE	TDA	SYSCOM
	SEE MIL-HDBK-236 (NAVY) "INDEX TO STANDARDS" FOR APPLICABLE TRUCKLOADING, CARLOADING AND CONTAINER LOADING DOCUMENTS.	B	ADDED CBU-59(T-1)/B TRAINING	8/15/71		
		A	CHANGED RESTRAINERS FROM STEEL TO WOOD AND UPDATED WR.	2/24/71		

**THIS UNIT LOAD IS AUTHORIZED
AND RELEASED FOR** SHIPPING, HANDLING,
STORAGE AND TRANSFER-AT-SEA. IT MAY ALSO BE USED FOR
DOMESTIC SHIPMENT IN COMPLIANCE WITH DOT REGULATIONS.

M.S. Gray NWHL 5/21/71
SIGNATURE TECHNICAL DIRECTING ACTIVITY (TDA) DATE
J. E. Kelly 5/24/71
SIGNATURE (AIR) SYSCOM, BY DIRECTION DATE

ORIGINATOR *Charles McBride* 5/24/71
SIGNATURE

NAVAL WEAPONS HANDLING LABORATORY
U.S.N.A.D. EARLE, NEW JERSEY

UNITIZING PROCEDURE

- (a) POSITION THE CONTAINERS SIDE BY SIDE, ALTERNATING THE FORE AND AFT ENDS, AS SHOWN.
- (b) INSERT THE RESTRAINERS, ITEM 1, THROUGH THE FORK POCKETS OF BOTH CONTAINERS.
- (c) POSITION STRAPPING, ITEM 2, THROUGH FORK POCKETS, AROUND RESTRAINERS, TENSION AND DOUBLE NOTCH SEAL, ITEM 4.
- (d) POSITION STRAPPING, ITEM 3, AROUND THE CONTAINERS, AS SHOWN. TENSION AND DOUBLE NOTCH SEAL.

MARKING:

IN ADDITION TO ANY SPECIAL MARKING REQUIRED BY CONTRACT OR ORDER, THE UNIT LOAD SHALL BE MARKED IN ACCORDANCE WITH MIL-STD-129.

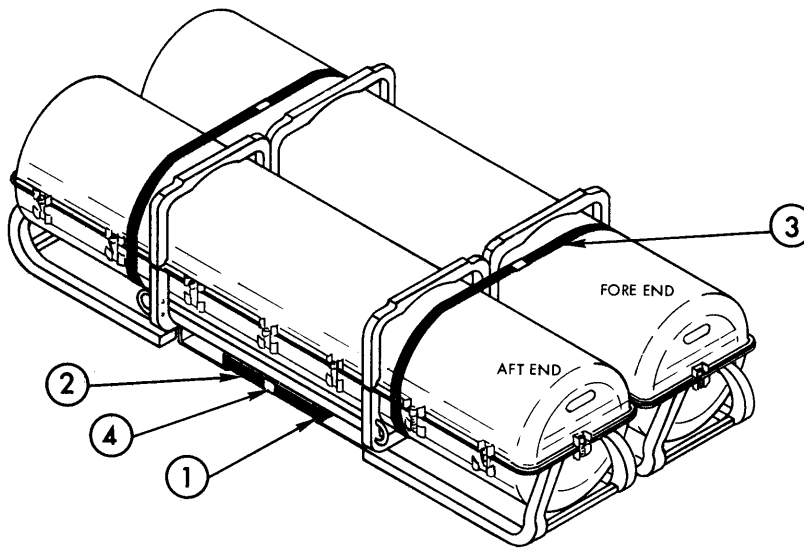

DEUNITIZING PROCEDURE

- (a) CUT AND REMOVE STRAPPING.
- (b) REMOVE RESTRAINERS.

NOTE: .031 COLD ROLLED, HEAT TREATED, MAY BE SUBSTITUTED.
DO NOT USE TYPE I STRAPPING WITH POWER MACHINES.

3	4	SEAL	STEEL COATED	QQ-5-781, TY D, CL H, FIN B	1 1/4
2	3	STRAPPING, SEE NOTE	STEEL COATED HEAVY DUTY	QQ-5-781, TY I OR IV, FIN B	1 1/4 X 035 X 12 FT
1	2	STRAPPING, SEE NOTE	STEEL COATED HEAVY DUTY	QQ-5-781, TY I OR IV, FIN B	1 1/4 X 035 X 11 FT
2	1	RESTRAINER	WOOD DRESSED	MM-L-751	2 X 3 X 38 3/4 (MAKE FROM 2 X 6)
REQ.	ITEM	DESCRIPTION	MAT'L	MAT'L SPEC.	DIMENSIONS
LIST OF MATERIALS					