

UNIT LOAD FOR UNDERWAY REPLENISHMENT DISPENSER AND BOMB, AIRCRAFT MK 20 SERIES, CBU-99 SERIES, CBU-100 SERIES (ROCKEYE), CBU-78 SERIES (GATOR) AND DISPENSER, SUU-76 SERIES IN CONTAINER, CNU-319/E

UNIT LOAD DATA	ROCKEYE OR GATOR	DISPENSER SUU-76
DISPENSERS PER CONTAINER	2	2
CONTAINERS PER UNIT LOAD	2	2
DISPENSERS PER UNIT LOAD	4	4
GROSS WEIGHT OF ONE CONTAINER	1513 LB.	760 LB.
WEIGHT OF STRAPPING	3 LB.	3 LB.
GROSS WEIGHT OF UNIT LOAD	3029 LB. Δ	1523 LB. Δ
CUBE	82.2 CU. FT.	82.2 CU. FT.

Δ DO NOT USE FOR SHIPPING WEIGHT.

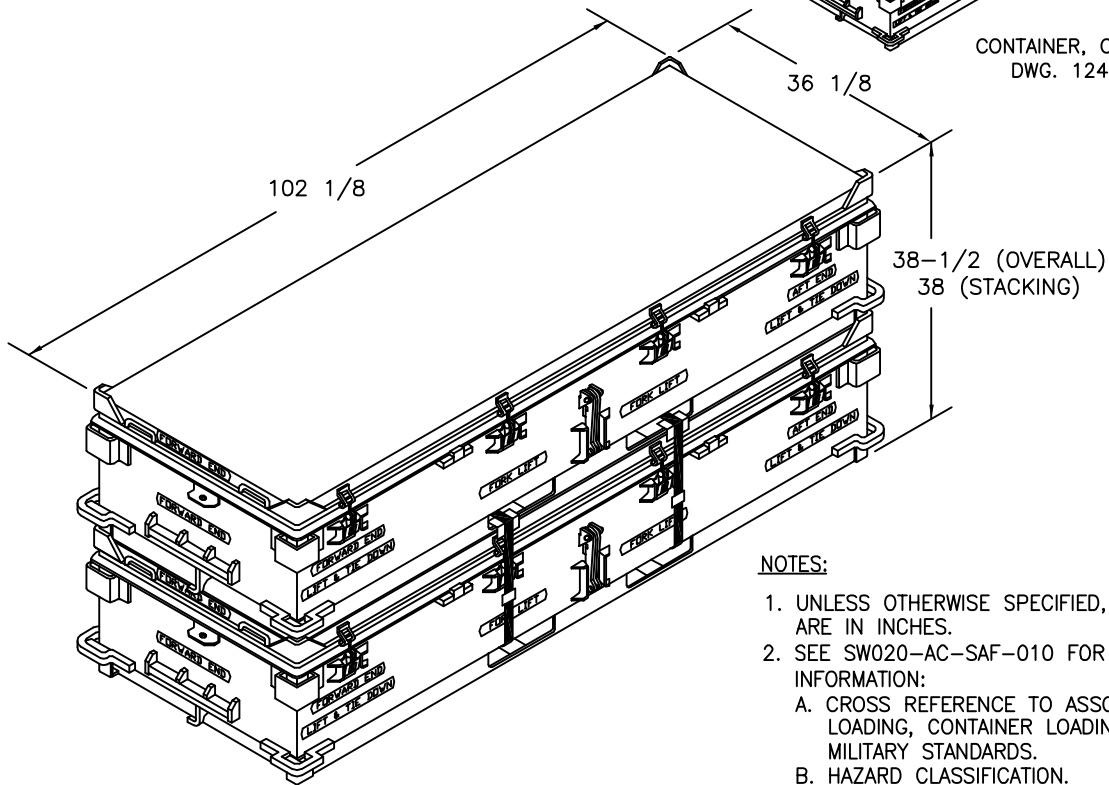
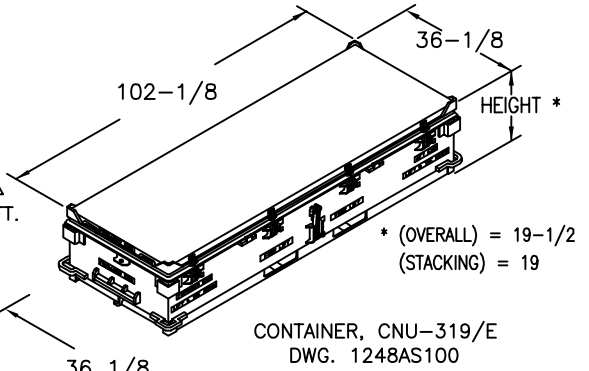

NOTES:

1. UNLESS OTHERWISE SPECIFIED, DIMENSIONS ARE IN INCHES.
2. SEE SW020-AC-SAF-010 FOR THE FOLLOWING INFORMATION:
 - A. CROSS REFERENCE TO ASSOCIATED TRUCK LOADING, CONTAINER LOADING & CAR LOADING MILITARY STANDARDS.
 - B. HAZARD CLASSIFICATION.
3. DO NOT STACK MORE THAN 4 UNIT LOADS HIGH IN STORAGE. PUT HEAVIER UNIT LOADS ON THE BOTTOM OF THE STACK.

-	ORIGINAL ISSUE, SUPERSEDES MIL-STD-1323-97B	1/31/02	S/AVS	S/KZ
REV.	REVISION DESCRIPTION	DATE	TDA	SYSCOM
TECH DATA MANAGEMENT SUPERVISOR	EP / S/AVS	1/31/02	DISTRIBUTION STATEMENT A APPROVED FOR PUBLIC RELEASE: DISTRIBUTION IS UNLIMITED REQUIREMENTS FOR CONSTRUCTION OF THIS LOAD SHALL CONSIST OF THIS DOCUMENT & THE LATEST ISSUE OF MIL-STD-1323 (NAVY). THIS LOAD IS AUTHORIZED & RELEASED FOR SHIPPING & STORAGE, TRANSFER-AT-SEA & FOR SHIPMENT BY COMMON CARRIER.	
SYSTEMS ENG. SUPERVISOR	S/GB	1/31/02		
S/K. H. ZIMMS		1/31/02		
NAVSEASYSKOM (BY DIRECTION)				
DEPARTMENT OF THE NAVY NAVAL SEA SYSTEMS COMMAND ARLINGTON, VA 22242-5160		CAGE CODE 53711	DWG NO. 6214274	REV. —
		SIZE A	PAGE 1 OF 2	

UNITIZING PROCEDURE

- (A) STACK TWO CONTAINERS, SO THAT THE TOP CONTAINER IS ENGAGED WITHIN THE STACKING ANGLES.
- (B) PLACE EDGE PROTECTOR, ITEM 3, ON FORK POCKETS OF TOP CONTAINER AS SHOWN.
- (C) THREAD STRAPPING, ITEM 1, THROUGH FORK POCKETS OF TOP AND BOTTOM CONTAINERS AND OVER THE EDGE PROTECTORS. TENSION AND DOUBLE NOTCH THE SEALS, ITEM 2.

MARKING:

IN ADDITION TO ANY SPECIAL MARKING REQUIRED BY CONTRACT OR ORDER, THE UNIT LOAD SHALL BE MARKED IN ACCORDANCE WITH 53711-6214251.

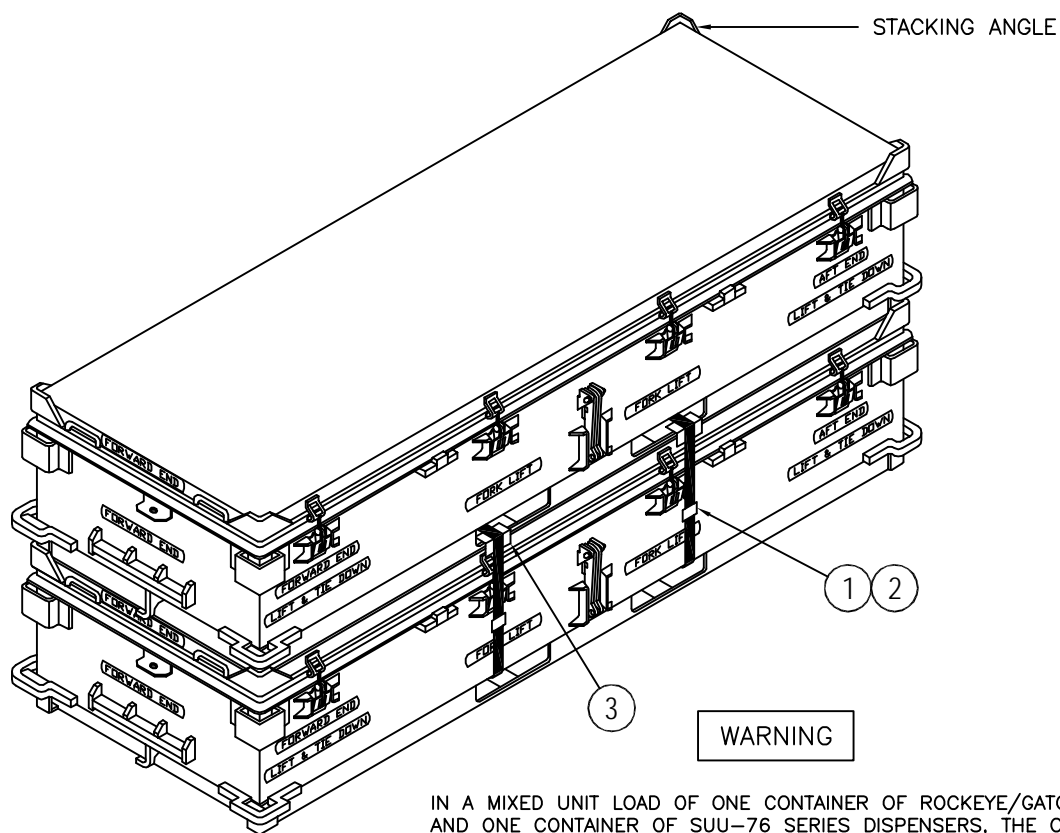

WARNING

IN A MIXED UNIT LOAD OF ONE CONTAINER OF ROCKEYE/GATOR AND ONE CONTAINER OF SUU-76 SERIES DISPENSERS, THE CONTAINER WITH ROCKEYE/GATOR SHALL BE ON THE BOTTOM OF THE UNIT LOAD.

NOTES:

- 1. UNLESS OTHERWISE SPECIFIED, ALL MATERIAL SHALL BE IAW THE GENERAL DOCUMENT MIL-STD-1323 (NAVY).
- 2. RIBBED EDGE PROTECTORS WITH MINIMUM .042 INCH THICKNESS AND MINIMUM 2 INCH LENGTH OF LEGS, DESIGNED FOR USE WITH 1-1/4 INCH WIDTH STRAPPING MAY BE SUBSTITUTED.

DEUNITIZING PROCEDURE

- (A) CUT AND REMOVE STRAPPING.
- (B) REMOVE EDGE PROTECTORS.
- (C) REMOVE TOP CONTAINER.

4	3	EDGE PROTECTOR	NSN 8135-00-291-0962	SEE NOTE 2
2	2	SEAL	STEEL	FOR 1-1/4 STRAPPING
2	1	STRAPPING	STEEL	1-1/4 X .035 X 9 FT 6
REQ'D	ITEM	DESCRIPTION	MAT'L/DWG	DIMENSIONS

LIST OF MATERIALS

NAVSEA
DWG NO.

6214274

REV. —

SIZE A

CAGE CODE
53711

PAGE 2 OF 2