

APPROVED BY
MTMTS

Frank S. Taus

TEA, MTMTS

DATE *17 Oct 1971*

NIKE-HERCULES

MINIMUM REQUIREMENTS FOR THE HANDLING, STOWAGE, AND BRACING ABOARD SHIPS OF ELECTRONIC SHOP, TRAILER MOUNTED, SET NO. 3

REVISIONS			DRAFTSMAN <i>WCH/SPD</i>	PROJ ENG <i>JNW/SBW</i>
			CHECKER <i>ARK/BBK</i>	AGE OFFICE <i>J. S. P.</i>
			APPROVED <i>Martin Johnson</i> U. S. ARMY MISSILE COMMAND APPROVED BY ORDER OF COMMANDING GENERAL U. S. ARMY MATERIEL COMMAND <i>A. L. H. Jr.</i> USAMC AMMO CENTER U. S. ARMY MATERIEL COMMAND	
			NOVEMBER 1971	
			CLASS	DIVISION
			19	48
			DRAWING	FILE
			7246	GSE 1BNH9

DO NOT SCALE

NOTES

GENERAL:

- A. THIS DOCUMENT HAS BEEN PREPARED AND ISSUED IN ACCORDANCE WITH AMCR 740-13.
- B. THIS DRAWING DEPICTS MINIMUM PROCEDURES APPLICABLE TO THE HANDLING, STOWAGE AND BRACING ABOARD SHIPS OF ELECTRONIC SHOP, TRAILER MOUNTED, SET NO. 3, FOR THE NIKE-HERCULES MISSILE SYSTEM.
- C. THE ELECTRONIC SHOP SHOWN HEREIN MAY BE STOWED IN THE SAME HOLD OR TWEEN DECK WITH OTHER TYPES OF CARGO.
- D. LADING DATA:
 - DIMENSIONS ----- 20'-0" LONG * X 6'-1" WIDE X 10'-4" HIGH.
 - GROSS WEIGHT -- 13,100 LBS (APPROX).
 - CUBE ----- 1,671 CU. FT.
 - * 26'-8" LONG WITH TOWBAR EXTENDED.

HANDLING:

- A. PERTINENT PROVISIONS OF TITLE 46 CODE OF FEDERAL REGULATIONS APPLY.
- B. HANDLING OF THE ELECTRONIC SHOP SHOULD BE ACCOMPLISHED BY THE USE OF SLING EXTENSIONS, PASSED THRU THE HOLES OF THE WHEELS AND SECURELY POSITIONED UNDER THE AXLES OF THE TRAILER AS SHOWN.
- C. THE HANDLING SLING SHALL BE OF A DESIGN AND CONFIGURATION TO LIFT THE ITEM IN SUCH A MANNER THAT THE CABLE LEGS DO NOT APPLY EXCESSIVE PRESSURE WHICH WILL DAMAGE THE ELECTRONIC SHOP WHEN BEING LIFTED.
- D. ALTHOUGH DESIRABLE, A LEVEL LIFT IS NOT MANDATORY. THE CENTER OF GRAVITY OF THIS ITEM IS SHOWN TO ASSIST IN DETERMINING CABLE LENGTHS TO ASSURE A SAFE LIFT.

STOWAGE AND BRACING:

- A. WHEN STOWING THE ELECTRONIC SHOP WITHIN THE HOLD OR TWEEN DECK, BRACING BETWEEN TRAILERS OR BETWEEN ELECTRONIC SHOP AND OTHER CARGO SHALL ONLY BE APPLIED AGAINST THE WHEELS OF THE TRAILER. ALSO, OTHER CARGO ITEMS MUST NOT BE STACKED ON TOP OF OR BE BRACED AGAINST ANY OTHER PART OF THE ELECTRONIC SHOP THAN AS IDENTIFIED IMMEDIATELY ABOVE.
- B. SPECIES, GRADE AND SIZE OF LUMBER TO BE USED WILL COMPLY WITH REQUIREMENTS OF CURRENT SHIPWRIGHT-CARPENTRY AND RELATED SERVICES CONTRACTS. BRACING METHODS AND LUMBER SIZES DEPICTED IN THIS DRAWING ARE CONSIDERED MINIMUM AND ARE NOT INTENDED TO CONFLICT WITH CONTRACT REQUIREMENTS.
- C. THE ELECTRONIC SHOP IS EQUIPPED WITH TIE DOWN FACILITIES AS SHOWN HEREIN AND ARE SYMMETRICAL ABOUT THE LONGITUDINAL LINE OF CENTER. THE ITEM SHOULD BE SECURED FORE AND AFT TO SHIP TIE DOWN POINTS USING A MINIMUM OF TWO SYMMETRICALLY LOCATED TIE DOWN FACILITIES IN EACH DIRECTION AS TYPICALLY SHOWN WITHIN THIS DOCUMENT.
- D. A TYPICAL TIE DOWN PROCEDURE IS SHOWN AND DEPICTS THE PREFERRED METHOD OF USING CABLES AND TURNBUCKLES. IF USED, A TURNBUCKLE MUST BE OF A SIZE EQUAL IN STRENGTH TO THE MINIMUM SIZE CABLE REQUIRED TO SECURE THE ITEM. IN LIEU OF CABLES AND TURNBUCKLES, SECUREMENT MAY BE ACCOMPLISHED BY OTHER ACCEPTED METHODS.

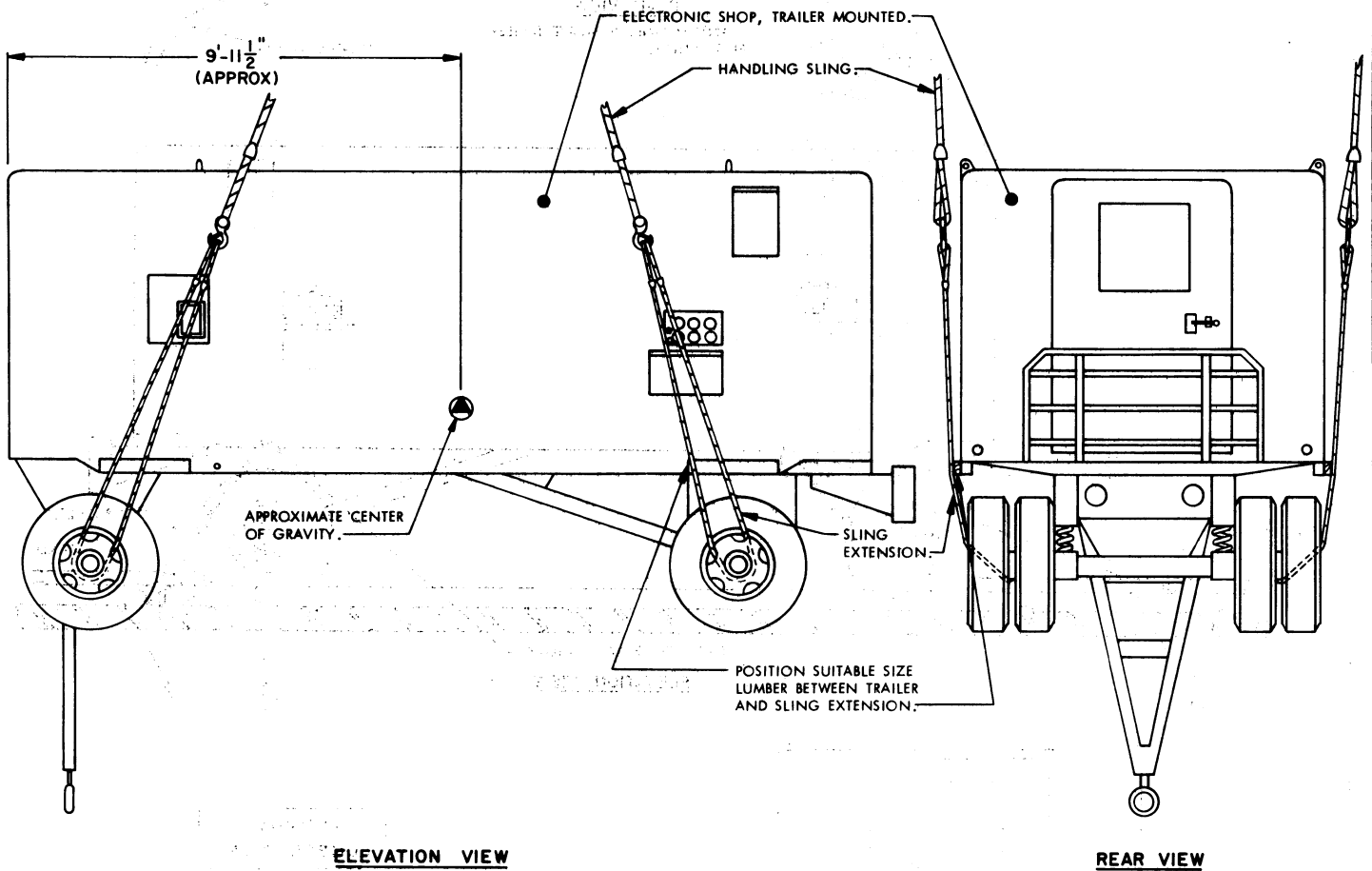

PRECAUTIONARY PROVISIONS FOR HANDLING, STOWAGE AND BRACING AS SPECIFIED IN THE NOTES ON PAGE 2 MUST BE OBSERVED.

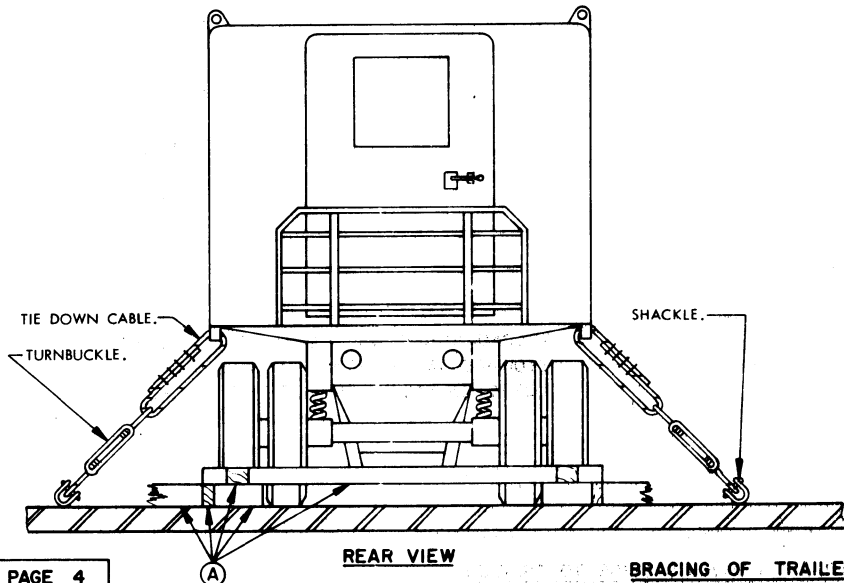
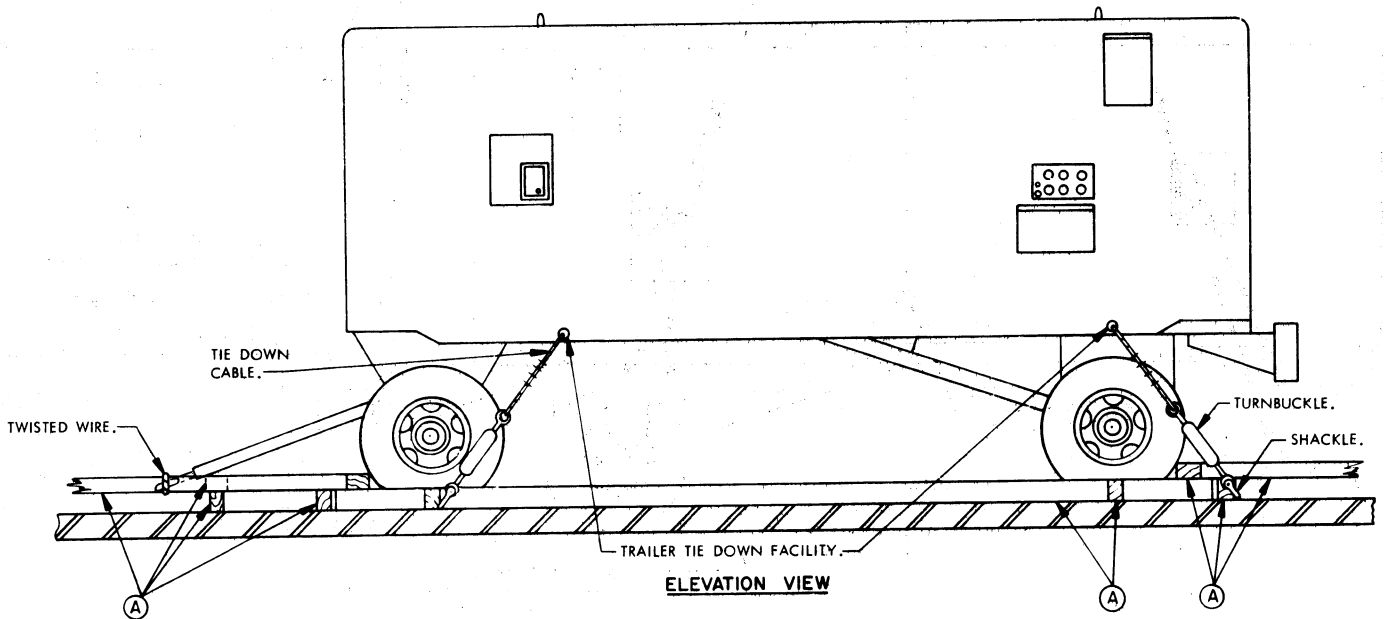
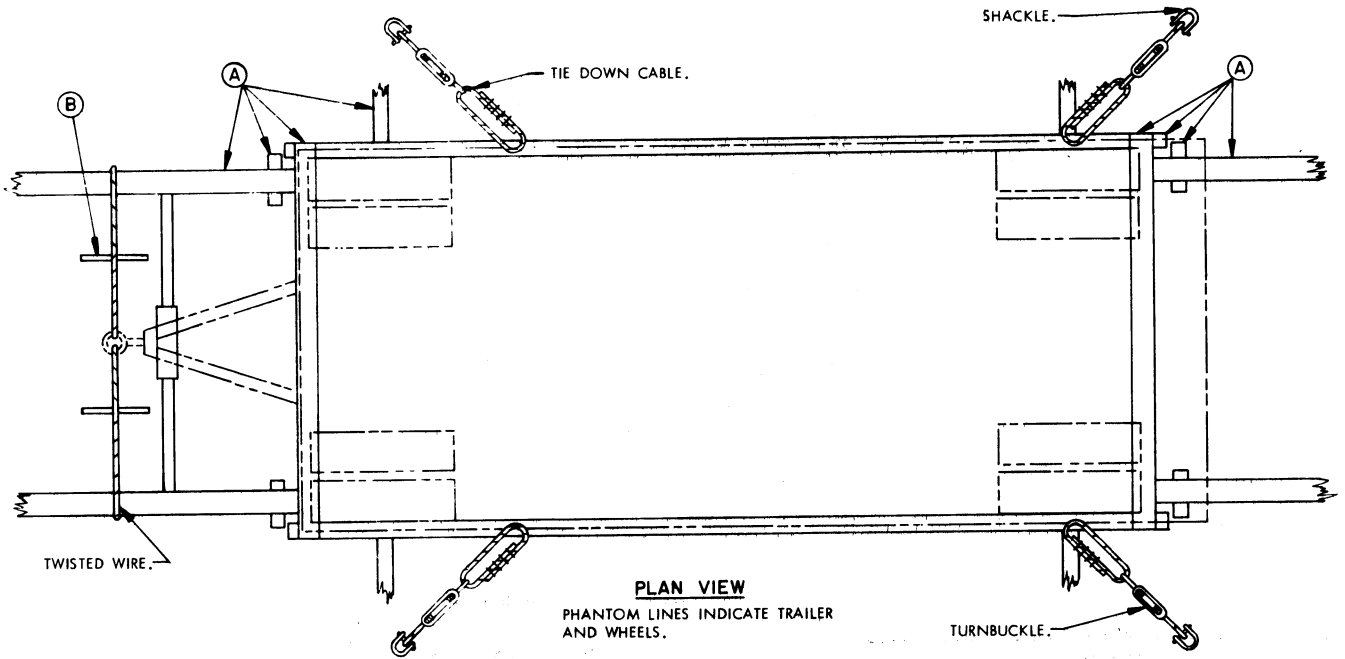

MINIMUM LUMBER SIZES	
(A)	4" X 6"
(B)	2" X 2"

PRECAUTIONARY PROVISIONS FOR HANDLING, STOWAGE AND BRACING AS SPECIFIED IN THE NOTES ON PAGE 2 MUST BE OBSERVED.