

MIL-STD-1325-179 (NAVY)  
Notice 1  
3 September 1982

MILITARY STANDARD  
RAILCAR LOADING  
DISPENSER AND BOMB, AIRCRAFT CBU-MK 20 AND MODS (ROCKEYE II)  
OR CBU-55/B, CBU-55A/B OR CBU-72/B (FAE) OR CBU-59B (APAM)  
IN CONTAINER CNU-238/E  
FLEET ISSUE UNIT LOAD

TO ALL HOLDERS OF MIL-STD-1325-179 (NAVY)

Page 1.

Title block. Add "or CBU-78/B (GATOR)".

Review Activities  
NAVY - OS, AS

Preparing Activity:  
NAVY - OS  
(Project #8140-N575)

# MILITARY STANDARD

MIL-STD-1325-179

(NAVY)

19 MARCH 1976

## RAILCAR LOADING OF HAZARDOUS MATERIALS DISPENSER AND BOMB, AIRCRAFT CBU-MK 20 AND MODS (ROCKEYE II) OR CBU-55/B, CBU-55 A/B OR CBU-72/B (FAE) OR CBU-59B (APAM) IN CONTAINER, CNU-238/E FLEET ISSUE UNIT LOAD

### UNIT LOAD DATA

UNIT LOAD DRAWING ..... SEE TABLE I  
WEIGHT (APPROX) ..... SEE TABLE I  
DIMENSIONS ..... 104 L X 38 W X 53 H  
(STACKING HEIGHT 52)  
CUBE ..... 121.2 CU FT  
DOT HAZARD CLASSIFICATION ..... EXPLOSIVES A

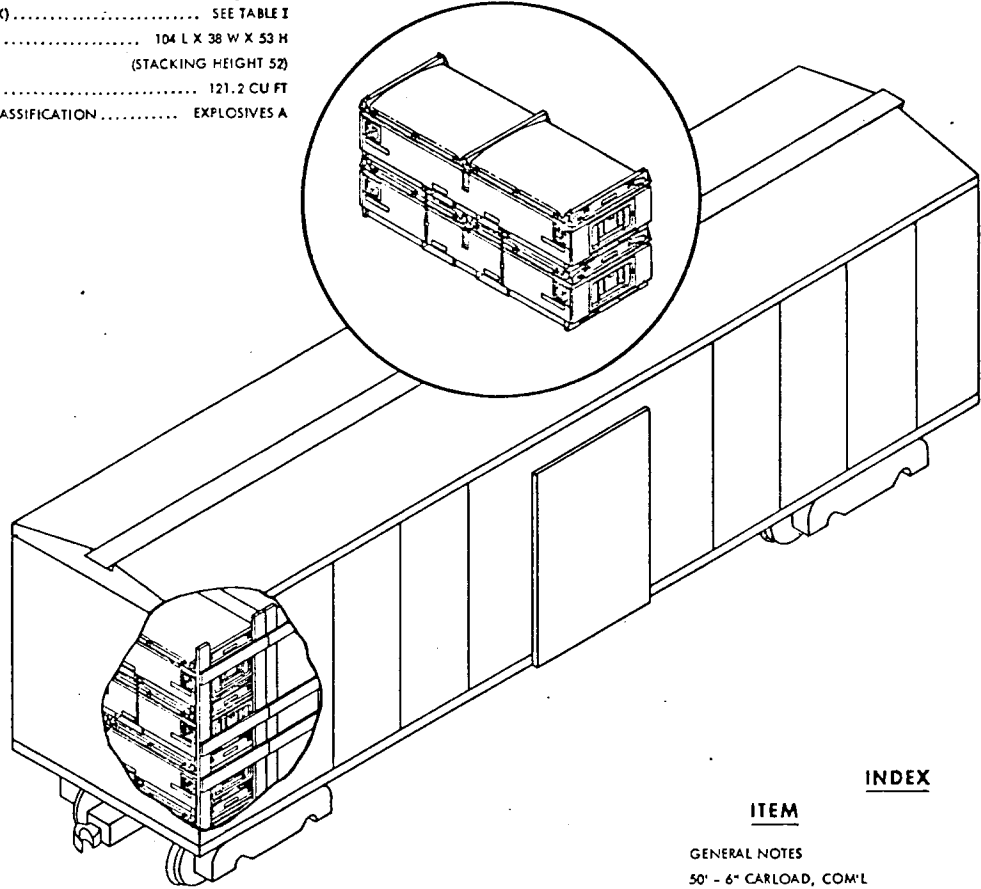

ITEM	INDEX	PAGE
GENERAL NOTES		2
50' - 6" CARLOAD, COM'L		3, 4

**NOTES:**

1. UNLESS OTHERWISE SPECIFIED DIMENSIONS ARE IN INCHES.
2. FOR CROSS REFERENCE TO ASSOCIATED PALLETIZING, TRUCK-LOADING AND CONTAINERLOADING MILITARY STANDARDS, REFER TO INDEX TO STANDARDS MIL-HDBK-236 (NAVY).

FSC 8140

**AUTHORIZED AND RELEASED FOR  
GENERAL USE.**

**APPROVED BY BUREAU OF EXPLOSIVES**

*A. F. Grassmuck* 2/5/76  
SIGNATURE SUPERVISOR, MILITARY & INTERMODEL SERVICES DATE

*M. S. Gray* NWHL 2/23/76  
SIGNATURE TECHNICAL DIRECTION AGENT (TDA) DATE

ORIGINATOR *Charles Mc Bride* 3/19/76  
SIGNATURE

*J. E. Kelly* 3/19/76  
SIGNATURE (AIR) SYSCOM. BY DIRECTION DATE

NAVAL WEAPONS HANDLING LABORATORY  
WPNSTA EARLE, NEW JERSEY

PAGE 1 OF 4

## GENERAL NOTES

1. FOR GENERAL INFORMATION CONCERNING ORDERING, INSPECTING, AND PREPARING CARS, AND FOR DUNNAGING MATERIALS, DESIGN, AND INSTALLATION OF DUNNAGE SEE THE GENERAL DOCUMENT MIL-STD-1325 (NAVY) "RAILCAR LOADING OF HAZARDOUS MATERIALS".
2. WHEN PLANNING SHIPMENTS ORDER THE MINIMUM NUMBER OF CARS OF THE CAPACITY REQUIRED FOR THE SHIPMENT.
3. LOADING PLANS SHOWN ARE FOR COMMERCIAL BOXCARS WITH 50 FT 6 IN INSIDE LENGTH, 110 IN INSIDE WIDTH AND WITH DOORS NOT LESS THAN 9 FT.
4. THE "LOAD LIMIT" OF A CAR MUST NOT BE EXCEEDED NOR SHOULD THE RAILCAR BE LOADED SO THAT MORE THAN ONE-HALF OF THE "LOAD LIMIT" IS CARRIED BY ONE SET OF TRUCKS.
5. IF END WALLS OF CARS ARE NOT SQUARE THEY MUST BE SQUARED OFF BEFORE STARTING TO LOAD CAR.
6. THE LOAD CONSISTS OF AIRCRAFT DISPENSER AND BOMB CBU-MK 20 AND MODS (ROCKEYE II) OR CBU-55/B, CBU-55 A/B OR CBU-72/B (FAE) OR CBU-59/B (AFAM) IN CONTAINER CNU-238/E PALLETIZED IN ACCORDANCE WITH WR-54/268, OR WR-54/269, OR WR-54/270 (SEE TABLE I).
7. THE UNIT LOADS ARE HANDED AND LOADED WITH A SUITABLE FORKLIFT TRUCK.
8. UNLESS OTHERWISE SPECIFIED NAILING SHALL BE IN ACCORDANCE WITH MIL-STD-1325 (NAVY).
9. ALL STRAP JOINTS SHALL BE CRIMP-TYPE JOINTS MADE WITH A CRIMPING TOOL THAT DOES NOT CUT THE SEAL OR STRAP, RATHER THAN A TOOL THAT MAKES A NOTCH-TYPE JOINT. THE STRAPPING MUST BE IN ACCORDANCE WITH NAVSUP NOTICE 4642 DATED 21 APRIL 1971.
10. APPLICABLE MATERIAL SPECIFICATIONS:
  - DUNNAGE LUMBER - FED SPEC MM-L-751
  - NAILS - FED SPEC FF-N-105
  - STRAPPING - FED SPEC QQ-S-781, TYPE I, HEAVY DUTY, CLASS A, DRY (UNLUBRICATED).
  - SEALS - FED SPEC QQ-S-781, STYLE III, HEAVY DUTY
11. AFTER BLOCKING AND BRACING HAS BEEN INSPECTED ATTACH SHIPPING DOCUMENTS INSIDE THE CAR IN AN ACCESSIBLE AREA, CLOSE AND SEAL BOXCAR DOORS, AND ATTACH APPLICABLE PLACARDS TO THE OUTSIDE OF CAR AS PRESCRIBED IN OP 2165 (VOL 1).

## 50 FT 6 IN. BOXCAR, COMMERCIAL

1. THE CARLOAD CONSISTS OF 30 UNIT LOADS WHICH MUST BE LOADED AND DUNNAGED IN ACCORDANCE WITH THIS PROCEDURAL DRAWING. WHEN LOADING 30 UNIT LOADS OF THE CBU-59/B (AFAM), PALLETIZED IN ACCORDANCE WITH WR-54/270, THE LOAD LIMIT OF THE BOXCAR MUST EXCEED 133,999 LBS. IF THE LOAD LIMIT OF THE BOXCAR IS LESS THAN 134,000 LBS BUT NOT LESS THAN 124,000 LBS, 28 UNIT LOADS OF THE CBU-59/B (AFAM) MAY BE LOADED IN THE CAR BY OMITTING ONE DOORWAY AREA STACK. TIE BARS ARE THEN REQUIRED FOR THE LONGER CENTER GATE STRUTS (SEE MIL-STD-1325 NAVY).
2. WHEN LESS THAN CARLOAD (LCL) QUANTITIES ARE REQUIRED TO BE SHIPPED IN COMMERCIAL BOXCARS AND A PARTIAL LAYER RESULTS, THE PARTIAL LAYER OF LADING SHALL BE BRACED BY MEANS OF END BRACING AND/OR PARTIAL LAYER BRACING CONSTRUCTED IN ACCORDANCE WITH MIL-STD-1325-100 (NAVY) OR PARTIAL UPPER LAYER BRACING IN ACCORDANCE WITH MIL-STD-1325-102 (NAVY). SELECT THE TYPE OF BRACE TO COMPLY WITH THE WEIGHT OF THE UNITS TO BE RETAINED. THE WEIGHT DISTRIBUTION REQUIREMENTS OF THE AAR MUST BE COMPLIED WITH, SEE MIL-STD-1325 (NAVY).
3. THE LOADS AS SHOWN ARE BASED ON CARS WHICH HAVE 10 FT WIDE DOORWAY OPENINGS AND ARE EQUIPPED WITH CONVENTIONAL SLIDING TYPE DOORS. THE DEPICTED PROCEDURES AND METHODS OF BLOCKING ARE APPLICABLE TO BOXCARS EQUIPPED WITH CONVENTIONAL SLIDING TYPE DOORS OTHER THAN 10 FT WIDE BUT NOT LESS THAN 9 FT WIDE.
4. THE DEPICTED PROCEDURES AND METHODS OF BLOCKING ARE ALSO APPLICABLE TO BOXCARS EQUIPPED WITH PLUG DOORS. DUNNAGE MATERIAL MUST NOT BE NAILED TO ANY PLUG DOOR, WHETHER MAIN OR AUXILIARY, EXCEPT WHEN THE CAR HAS A COMBINATION OF A CONVENTIONAL SLIDING TYPE DOOR AND A PLUG TYPE DOOR AND AN ADEQUATE NAILING STRIP IS PROVIDED ON THE PLUG TYPE DOOR. DIMENSIONAL LUMBER DOORWAY PROTECTION, PIECES 10 AND 11, IS NOT REQUIRED WHEN PLUG DOOR EQUIPPED BOXCARS ARE USED EXCEPT WHEN CAR HAS A COMBINATION OF PLUG DOOR AND CONVENTIONAL SLIDING DOOR. THEN DIMENSIONAL LUMBER DOORWAY PROTECTION IS REQUIRED FOR THE CONVENTIONAL DOOR. PLUG DOORS MUST BE SECURELY CLOSED AND WIRED TOGETHER WITH A STRONG FLEXIBLE STEEL WIRE INSERTED THROUGH THE HOLES IN THE DOOR LATCH ASSEMBLY ONE OR MORE TIMES AND THE WIRE ENDS TWISTED TOGETHER.

TABLE I

AIRCRAFT DISPENSER & BOMB ITEM	DRAWING NO.	UNIT LOAD WEIGHT (LBS) (APPROXIMATE)
CBU-MK 20 & MODS (ROCKEYE II) DODIC/NALC NO. E173, E819	WR-54/268	3325
CBU-55/B, CBU-55 A/B OR CBU-72/B (FAE) DODIC/NALC NO. E807, E821, E832	WR-54/269	3405
CBU-59/B (AFAM)	WR-54/270	4325

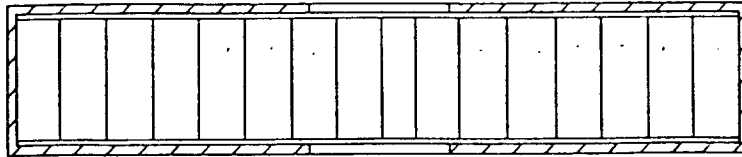

LOADING PLAN

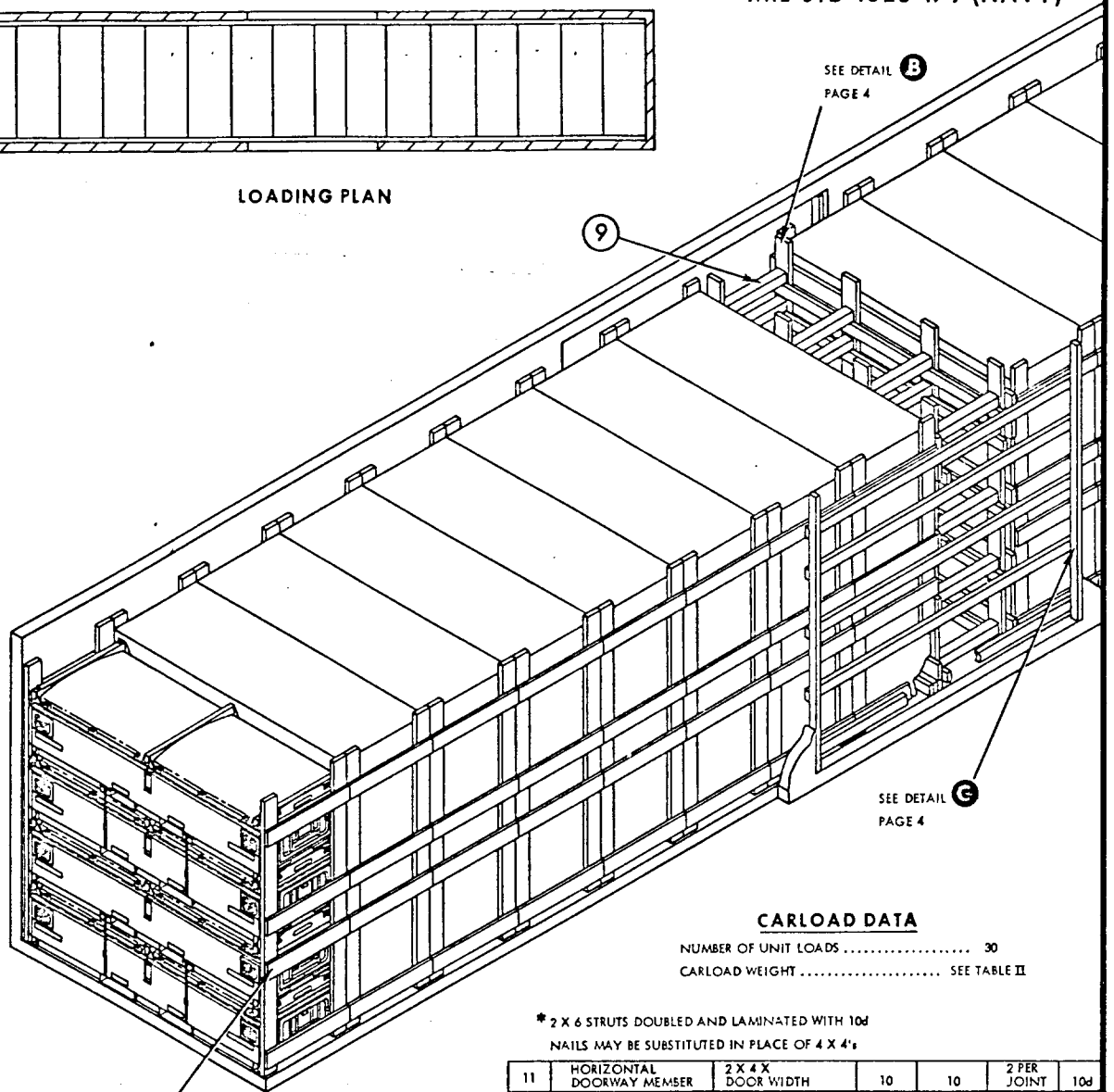

SEE DETAIL **B**  
PAGE 4

SEE DETAIL **C**  
PAGE 4

SEE DETAIL **A**

**CARLOAD DATA**

NUMBER OF UNIT LOADS ..... 30  
CARLOAD WEIGHT ..... SEE TABLE II

\* 2 X 6 STRUTS DOUBLED AND LAMINATED WITH 10d  
NAILS MAY BE SUBSTITUTED IN PLACE OF 4 X 4's

11	HORIZONTAL DOORWAY MEMBER	2 X 4 X DOOR WIDTH	10	10	2 PER JOINT	10d
10	VERTICAL DOORWAY MEMBER	2 X 3 X 108	4	DOOR POST	2 PER FOOT	20d
9	STRUT	4 X 4 X WEDGE FIT*	20	4	2 PER JOINT	16d
8	CENTER GATE HOLD DOWN	2 X 4 X TO SUIT	2	7	4	10d
7	CENTER GATE HOLD DOWN	2 X 4 X TO SUIT	2	6	4	10d
6	CENTER GATE FILLER	2 X 4 X CAR WIDTH - 1/2	2	4	3 PER JOINT	10d
5	CENTER GATE STRUT CLEAT	2 X 4 X CAR WIDTH - 1/2	10	4	3 PER JOINT	10d
4	CENTER GATE VERTICAL	2 X 6 X 108	8	SEE 3, 5, 6	-	-
3	CENTER GATE HORIZONTAL	2 X 6 X CAR WIDTH - 1/2	10	4	3 PER JOINT	10d
2	SWAY BRACE VERTICAL	2 X 6 X 108	60	SEE 1	-	-
1	SWAY BRACE HORIZONTAL	1 X 6 X 38	120	2	3 PER JOINT	10d
PIECE NO.	DESCRIPTION	SIZE	NO. OF PIECES REQ'D	NAIL TO	NUMBER	SIZE

TABLE II

AIRCRAFT DISPENSER & BOMB ITEM	CARLOAD WEIGHT (LBS)* (APPROXIMATE)
CBU-MK 20 & MODS (ROCKEYE II) DODIC/NALC NOS. E173, EB19	102,335
CBU-55/B, CBU-55 A/B OR CBU-72B (FAE)	104,735
CBU-59/B (APAM)	132,335 **

\* INCLUDES 2585 LBS (APPROX) DUNNAGE WEIGHT  
\*\* LOAD LIMIT OF BOXCAR MUST EXCEED 133,999 LBS

LIST OF MATERIALS & NAILING DATA

MIL-STD-1325-179 (NAVY)

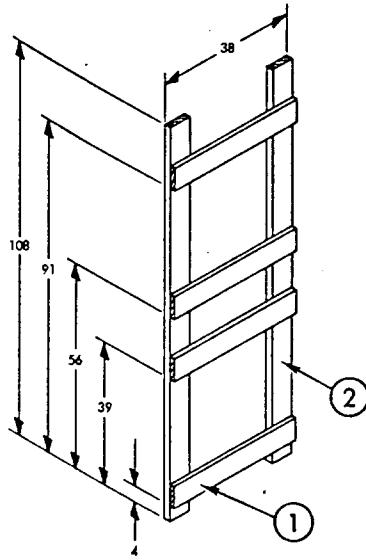

**DETAIL A**  
SWAY BRACE FRAME  
30 REQUIRED

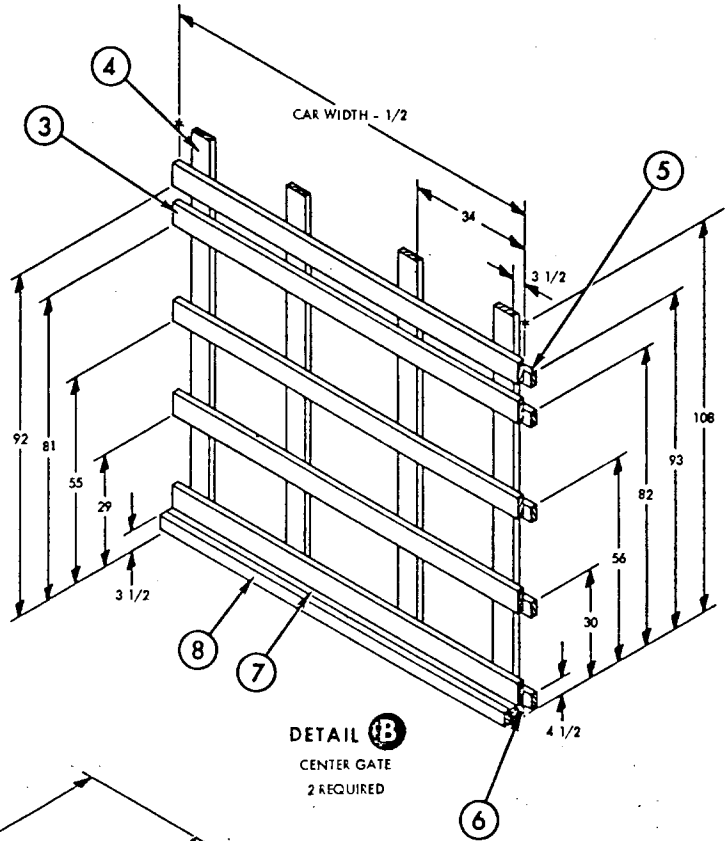

**DETAIL B**  
CENTER GATE  
2 REQUIRED

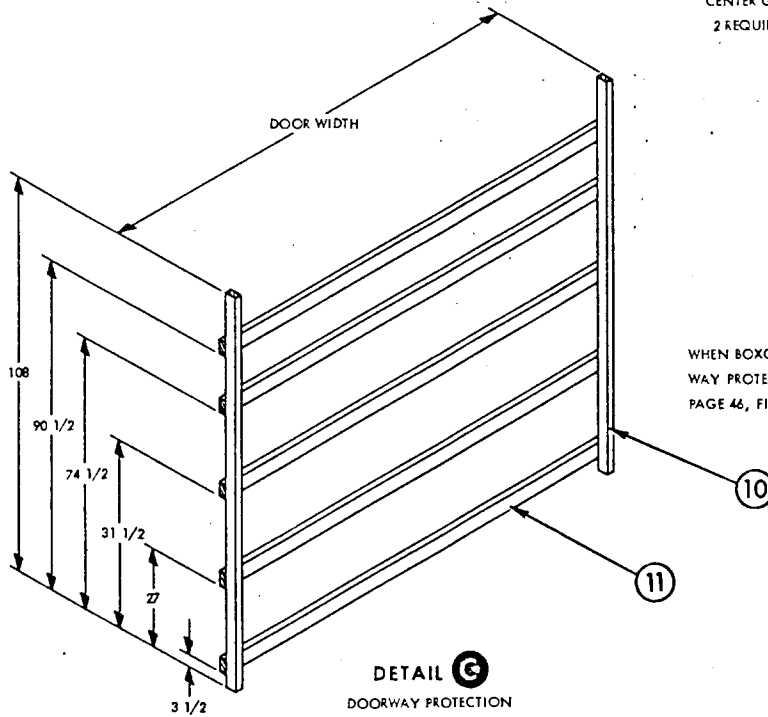

**DETAIL C**  
DOORWAY PROTECTION  
2 REQUIRED

WHEN BOXCAR HAS STEEL DOOR POSTS DOORWAY PROTECTION AS PER MIL-STD-1325 (NAVY) PAGE 46, FIG 21 IS REQUIRED.

REVIEW ACTIVITY  
NAVY - OS, AS

PREPARING ACTIVITY  
NAVY - OS  
(PROJECT NO. 8140-N325)