

# STORAGE IN APPROVED MAGAZINES OF GUIDANCE CONTROL UNIT, WGU- 12, WGU-25, WGU-36 AND WGU-39 PACKED IN CNU-371 METAL CON- TAINERS, PALLETIZED

ITEM	INDEX	PAGE(S)
GENERAL NOTES AND MATERIAL SPECIFICATIONS	- - - - -	2
PALLET UNIT DETAILS	- - - - -	3
TYPICAL STORAGE IN ARCHED OR ROUNDED ROOF MAGAZINES	- - - - -	4-7
CORBETTA MAGAZINE	- - - - -	8, 9
100' -8" L X 50' -0" W RECTANGULAR MAGAZINE	- - - - -	10, 11
TYPICAL MULTIPLE-LOT STORAGE PROCEDURES	- - - - -	12-14
FLOOR DUNNAGE AND SHIM LOCATION DETAILS	- - - - -	15

## U.S. ARMY MATERIEL COMMAND DRAWING

<b>APPROVED U.S. ARMY RESEARCH, DEVELOPMENT AND ENGINEERING COMMAND</b>  PENNOCK.AMAN DA.C.1380042157  <small>Digitally signed by PENNOCK.AMAN DA.C.1380042157 DN: cn=US, ou=U.S. Government, ou=DoD, ou=PKI, ou=USA, cn=PENNOCK.AMAN DA.C.1380042157 Date: 2017.07.12 15:49:18 -0500</small>  RDAR-EIL-TP		<b>CAUTION: VERIFY PRIOR TO USE AT <a href="https://mhp.redstone.army.mil">HTTPS://MHP.REDSTONE.ARMY.MIL</a> THAT THIS IS THE MOST CURRENT VERSION OF THIS DOCUMENT. THIS IS PAGE 1 OF 16.</b>			
		<b>DO NOT SCALE</b>		<b>JUNE 2017</b>	
DESIGN ENGINEER		BASIC	QUYEN TRAN		
		REV.			
<b>APPROVED BY ORDER OF COMMANDING GENERAL, U.S. ARMY MATERIEL COMMAND</b>  SHIMP.UPTON .R.1231257183  <small>Digitally signed by SHIMP.UPTON.R.1231257183 DN: cn=US, ou=U.S. Government, ou=DoD, ou=PKI, ou=USA, cn=SHIMP.UPTON.R.1231257183 Date: 2017.07.13 10:34:18 -0500</small>		ENGINEERING DIVISON	FIEFFER.LAUR A.A.1230375727  <small>Digitally signed by FIEFFER.LAUR A.A.1230375727 DN: cn=US, ou=U.S. Government, ou=DoD, ou=PKI, ou=USA, cn=FIEFFER.LAUR A.A.1230375727 Date: 2017.05.30 08:30:20 -0500</small>		
TEST ENGINEER		FELICIANO.AD IN.1259200373  <small>Digitally signed by FELICIANO AD IN.1259200373 DN: cn=US, ou=U.S. Government, ou=DoD, ou=PKI, ou=USA, cn=FELICIANO AD IN.1259200373 Date: 2017.05.06 10:05:54 -0500</small>			
TEST REPORT		NA		CLASS	DIVISION
EXPLOSIVE SAFETY DIRECTORATE		TIRONE.JOSEPH.A NDREW.102668374 9  <small>Digitally signed by TIRONE.JOSEPH.A NDREW.102668374 DN: cn=US, ou=U.S. Government, ou=DoD, ou=PKI, ou=USA, cn=TIRONE.JOSEPH.A NDREW.102668374 Date: 2017.06.20 11:28:43 -0500</small>		19	48
U.S. ARMY DEFENSE AMMUNITION CENTER				DRAWING	FILE
				8861	SP1-3-4-14-22PM5

## GENERAL NOTES

## (GENERAL NOTES CONTINUED)

- A. THIS DOCUMENT HAS BEEN PREPARED AND ISSUED IN ACCORDANCE WITH AR 740-1 AND AUGMENTS TM 743-200-1 (CHAPTER 5).
- B. THE STORAGE PROCEDURES DEPICTED WITHIN THIS DOCUMENT ARE APPLICABLE FOR STORAGE IN VARIOUS TYPES AND SIZES OF MAGAZINES. THE STORAGE PROCEDURES DEPICTED FOR THE SPECIFIC TYPES OF MAGAZINES MAY ALSO BE UTILIZED TO STORE PALLETIZED WGU-12, WGU-25, WGU-36, AND WGU-39 GUIDANCE CONTROL UNITS PACKED IN CNU-371 CONTAINERS IN OTHER TYPES OF APPROVED MAGAZINES. MINOR ADJUSTMENTS MAY BE MADE TO FACILITATE STORAGE IN OTHER TYPES OF MAGAZINES; HOWEVER, THE BASIC PRINCIPLES AS DEPICTED HEREIN WILL BE FOLLOWED.
- C. THE STORAGE PROCEDURES SPECIFIED IN THIS DRAWING ARE APPLICABLE TO WGU-12, WGU-25, WGU-36, AND WGU-39 GUIDANCE CONTROL UNITS PACKED IN CNU-371 CONTAINERS, PALLETIZED. SUBSEQUENT REFERENCE TO PALLET UNIT HEREIN MEANS PALLET UNIT WITH ITEMS. SEE PAGE 3 AND NAVSEA DRAWING 6214084 FOR DETAILS OF THE PALLET UNIT.
- D. **CAUTION:** THE ALLOWABLE "EXPLOSIVE LIMIT" ESTABLISHED FOR A MAGAZINE IS NOT TO BE EXCEEDED. THIS LIMITATION MAY REQUIRE A QUANTITY REDUCTION FROM THE STORAGE AS SHOWN.
- E. STORED PALLET UNITS MUST NOT CONTACT THE SIDES OF A MAGAZINE. THEREFORE, PALLET UNITS MUST BE STORED A MINIMUM OF 6" FROM THE SIDEWALL OR CURVATURE OF THE MAGAZINE AS APPLICABLE. TO PROVIDE FOR THIS MANDATORY CLEARANCE REQUIREMENT, PALLET UNITS MAY BE ELIMINATED FROM THE DEPICTED STORAGE PATTERN AS NECESSARY.
- F. AISLE DIMENSION SHOWN FOR STORAGE PROCEDURES IN MAGAZINES MAY BE ADJUSTED TO SUIT LOCAL CONDITIONS, VARIATIONS IN PALLET UNIT DIMENSIONS, AND/OR AVAILABLE MATERIAL HANDLING EQUIPMENT (MHE). HOWEVER, A 24" MINIMUM INSPECTION AISLE MUST BE MAINTAINED AT THE END OF THE PALLET UNITS WHERE HUMIDITY INDICATORS ARE LOCATED.
- G. THE MAXIMUM FLOOR LOAD FOR A MAGAZINE AS PRESCRIBED WILL NOT BE EXCEEDED.
- H. IF AVAILABLE MHE PERMITS, ADDITIONAL PALLET UNITS MAY BE STORED WITHIN THE MHE AREA AND/OR OTHER AVAILABLE AREA OF THE MAGAZINE.
- J. THE HEIGHT OF THE PACKAGE GUARD ON SOME FORKLIFT TRUCKS MAY NOT PERMIT PLACEMENT OF SOME TOP LAYER PALLET UNITS IN THE STACKS SHOWN IN THE STORAGE VIEWS HEREIN, UNLESS TWO UPPER PALLET UNITS ARE HANDLED AS ONE LIFT OR THE PACKAGE GUARD IS REMOVED (TINE CARRIAGE WILL IN MOST INSTANCES PROVIDE ADEQUATE PACKAGE GUARD PROTECTION). ONLY A FORKLIFT TRUCK OF ADEQUATE CAPACITY WILL BE USED WHEN LIFTING TWO PALLET UNITS AS ONE LIFT.
- K. THE USE OF "FLOOR DUNNAGE" IS OPTIONAL, ALTHOUGH THE USE OF THIS TYPE OF DUNNAGE IS DELINEATED WITHIN THIS STORAGE PROCEDURE DRAWING. THE PURPOSE OF FLOOR DUNNAGE IS TO KEEP THE BOTTOM DECKBOARDS OF THE PALLET DRY, THUS AIDING IN PREVENTING DETERIORATION. THEREFORE, FLOOR DUNNAGE SHOULD BE USED WHEN STORING IN A MAGAZINE THAT IS KNOWN TO HAVE A "DAMP" FLOOR. ALSO, IN LIEU OF USING ONE-INCH THICK FLOOR DUNNAGE AS SPECIFIED, THE USE OF THICKER FLOOR DUNNAGE MAY BE REQUIRED, AND SHOULD BE USED, TO ACHIEVE THE DESIRED OBJECTIVE. **NOTE:** SOME VIEWS WITHIN THIS DRAWING WILL NOT DEPICT ALL FLOOR DUNNAGE THAT IS REQUIRED WHEN DUNNAGE IS USED. FLOOR DUNNAGE IS SHOWN AT SOME LOCATIONS TO PROVIDE POSITIONING GUIDANCE. SEE GENERAL NOTE "S" AT RIGHT.
- (CONTINUED AT RIGHT)
- L. WHEN LOCAL STORAGE CONDITIONS ARE SUCH THAT AN AMMUNITION STORAGE MAGAZINE NET EXPLOSIVE WEIGHT LIMIT WILL BE REACHED BEFORE ALL AVAILABLE STORAGE SPACE WILL BE UTILIZED, A COMBINATION OF THE VARIOUS STORAGE PATTERNS DELINEATED HEREIN MAY BE USED IN LIEU OF BLOCK STORAGE PATTERNS TO FACILITATE INVENTORY, INSPECTION, THE USE OF MATERIAL HANDLING EQUIPMENT, SURVEILLANCE, ETC., OF THE AMMUNITION TO BE STORED WITHIN THE MAGAZINE.
- M. STORAGE OF MULTIPLE LOTS IN A MAGAZINE WILL REQUIRE CAREFUL PRE-PLANNING SO AS TO INSURE MHE ACCESSIBILITY TO ANY LOT IN ACCORDANCE WITH REQUIREMENTS SET FORTH IN THE APPLICABLE "SPECIAL NOTES" SECTIONS OF THE MULTIPLE LOT STORAGE PROCEDURES SHOWN ON PAGES 12 THRU 14.
- N. ALTHOUGH SPECIFIC PROCEDURES ARE INCLUDED IN THIS DRAWING FOR STORING MULTIPLE LOTS WITHIN ONE STRUCTURE, THE BASIC STORAGE PATTERNS AS SHOWN ON PAGES 4 THRU 11 CAN ALSO BE ADAPTED FOR STORAGE OF MORE THAN ONE LOT. MULTIPLE LOTS OF PALLET UNITS MAY BE STORED WITH ONE OR MORE ROWS USED FOR EACH LOT WHEN STORED IN ACCORDANCE WITH THE BASIC STORAGE PATTERN FOR ARCHED OR ROUNDED ROOF MAGAZINES (A ROW RUNS FROM THE REAR OF THE MAGAZINE TO THE FRONT). A SPACE OF APPROXIMATELY 1" WILL HAVE TO BE LEFT BETWEEN ADJACENT ROWS CONTAINING DIFFERENT LOTS. MULTIPLE LOTS OF PALLET UNITS MAY BE STORED WITH ONE OR MORE STACKS USED FOR EACH LOT WHEN STORED IN ACCORDANCE WITH THE BASIC STORAGE PATTERN FOR CORBETTA OR RECTANGULAR MAGAZINES. AN MHE AISLE MUST BE PROVIDED FROM THE DOOR TO THE REAR WALL OF THE MAGAZINE FOR MHE ACCESS TO ALL LOTS. ALL THE ADDITIONAL CRITERIA PERTAINING TO MULTIPLE LOT STORAGE WILL APPLY AS SPECIFIED ON PAGES 12 THRU 14.
- O. ANY "LIGHT" PALLET UNIT THAT DOES NOT CONTAIN A FULL QUANTITY OF GUIDANCE CONTROL UNITS WILL NOT BE BURIED IN STORAGE, IT MUST BE POSITIONED ADJACENT TO AN AISLE, PREFERABLY IN FRONT OF THE LOT.
- P. A PRODUCTION OR STORAGE FACILITY IS AUTHORIZED TO HAVE ONE INCOMPLETE, UN-BANDED PARTIAL UNIT LOAD PER LOT IN A STORAGE STRUCTURE. THE PALLET UNIT MUST BE RE-BANDED WITH THE SAME SIZE AND QUANTITY OF STRAPS AS THE ORIGINAL UNIT.
- Q. PALLET UNITS PRESENTLY STORED IN ACCORDANCE WITH A PRIOR APPROVED DRAWING NEED NOT BE RE-STORED SOLELY TO CONFORM TO THE PROCEDURES SPECIFIED IN THIS DOCUMENT.
- R. OTHER COMPATIBLE ITEMS MAY BE STORED IN A MAGAZINE, WHICH IS PARTIALLY FILLED WITH THE DESIGNATED ITEM.
- S. IN IGLOO, ARCH TYPE AND STRADLEY MAGAZINES WHICH HAVE SLOPING FLOORS, THE DEPICTED STORAGE PATTERNS, IN SOME CASES, INCLUDE PALLET UNIT STACKS WHICH STRADDLE THE RIDGE OF THE FLOOR AT THE CENTER OF THE MAGAZINE. FLOOR DUNNAGE IN THE FORM OF SHIMS WILL BE USED AS REQUIRED TO ACHIEVE SOUND AND ACCEPTABLE STABLE STACKS. SEE THE DETAIL ON PAGE 15.
- T. PORTIONS OF THE MAGAZINES, SUCH AS SIDEWALLS, END WALLS, AND ROOFS HAVE NOT BEEN SHOWN IN THE STORAGE VIEWS FOR CLARITY PURPOSES.
- U. DUNNAGE LUMBER SPECIFIED THROUGHOUT THIS PROCEDURAL DRAWING IS OF NOMINAL SIZE. FOR EXAMPLE, 1" X 4" MATERIAL IS ACTUALLY 3/4" THICK BY 3-1/2" WIDE AND 2" X 6" MATERIAL IS ACTUALLY 1-1/2" THICK BY 5-1/2" WIDE.
- V. CONVERSION TO METRIC EQUIVALENTS: DIMENSIONS WITHIN THIS DOCUMENT ARE EXPRESSED IN INCHES, AND WEIGHTS ARE EXPRESSED IN POUNDS. WHEN NECESSARY, THE METRIC EQUIVALENT MAY BE COMPUTED ON THE BASIS OF ONE INCH EQUALS 25.4MM, AND ONE POUND EQUALS 0.454 KG.

## MATERIAL SPECIFICATIONS

LUMBER - - - - - : SEE TM 743-200-1 (DUNNAGE LUMBER) AND VOLUNTARY PRODUCT STANDARD PS 20.

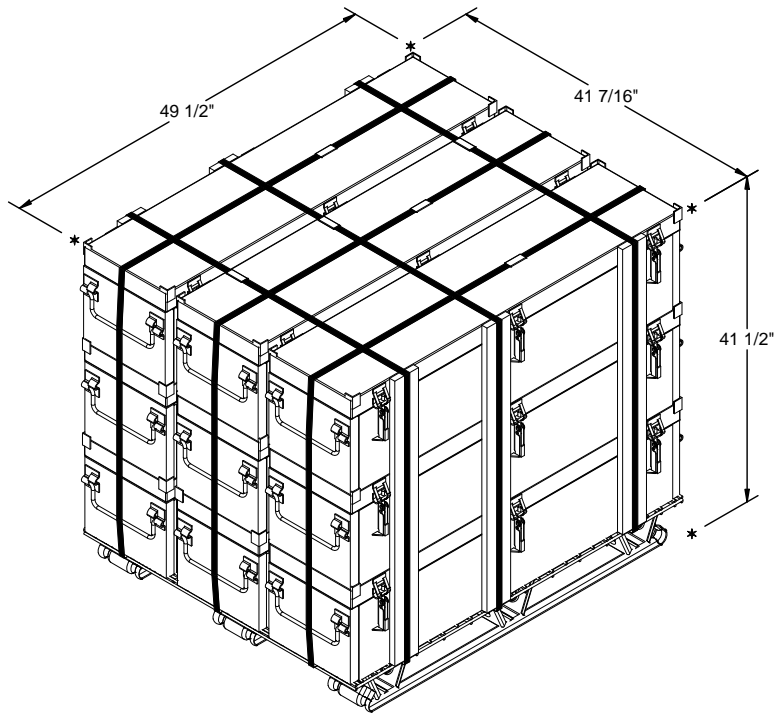

**PALLET UNIT**

GROSS WEIGHT - - - - - 1,400 LBS (APPROX)  
 CU BE - - - - - 49.3 CU FT (APPROX)

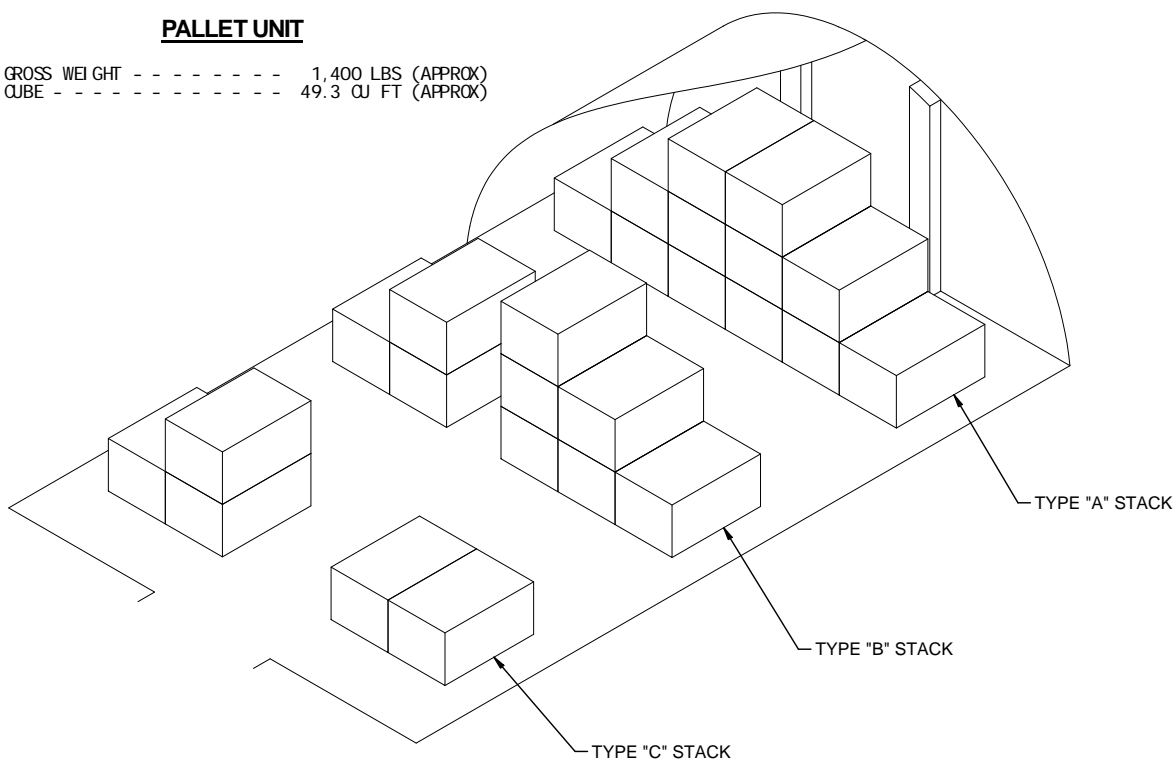

**STACK IDENTIFICATION**

A TYPE "A" STACK IS IDENTIFIED AS A GROUP OF ITEMS /UNITS WHICH EXTENDS FULL WIDTH AND HEIGHT OF THE MAGAZINE, AND IS ONE ITEM/UNIT LONG IN THE LENGTH OF THE MAGAZINE.

A TYPE "B" STACK IS IDENTIFIED AS A GROUP OF ITEMS/UNITS WHICH EXTEND FULL WIDTH AND HEIGHT OF THE MAGAZINE, AND IS ONE UNIT/ITEM LONG, BUT HAS AN AISLE AT OR NEAR THE CENTER OF THE WIDTH OF THE STACK.

A TYPE "C" STACK IS IDENTIFIED AS A GROUP OF ITEMS/UNITS WHICH IS ONE UNIT/ITEM LONG AND CONSISTS OF PARTIAL STACKS ON EACH SIDE OF THE MAGAZINE, USUALLY ONE ITEM/UNIT HIGH ON ONE SIDE OF THE MAGAZINE.

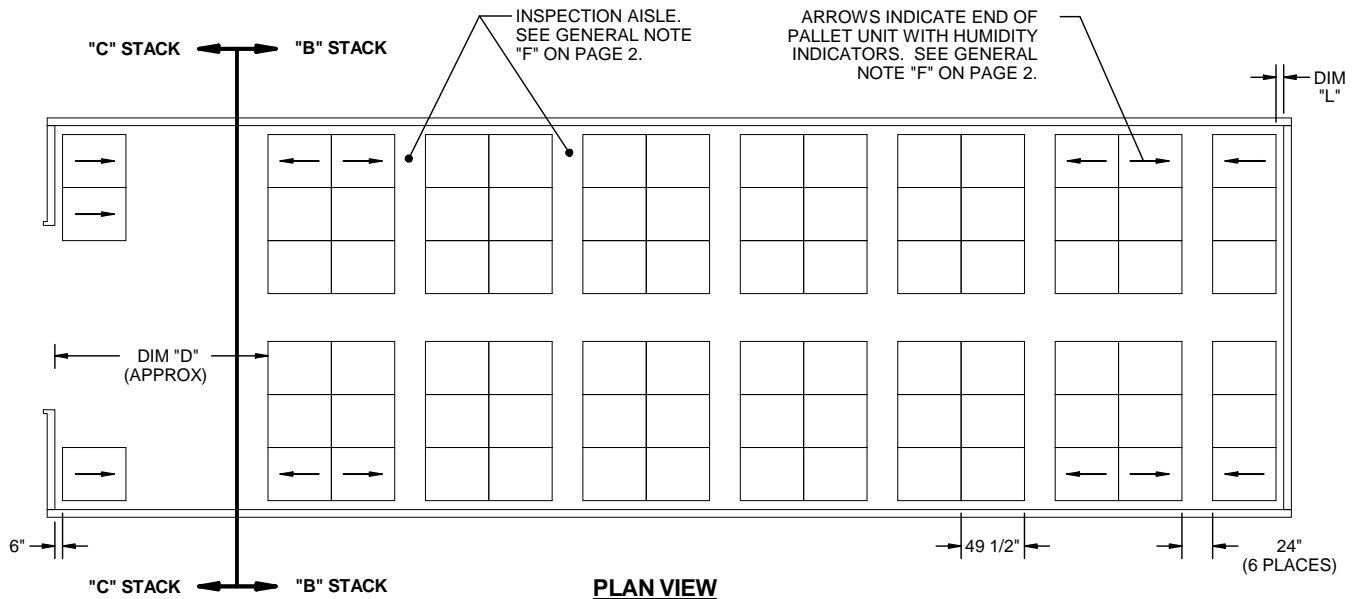

**PLAN VIEW**

**NOTE:** FOR IDENTIFICATION OF LETTERED DIMENSIONS REFER TO CHART 1 ON PAGE 6.

**STACK COLUMN DESIGNATIONS**

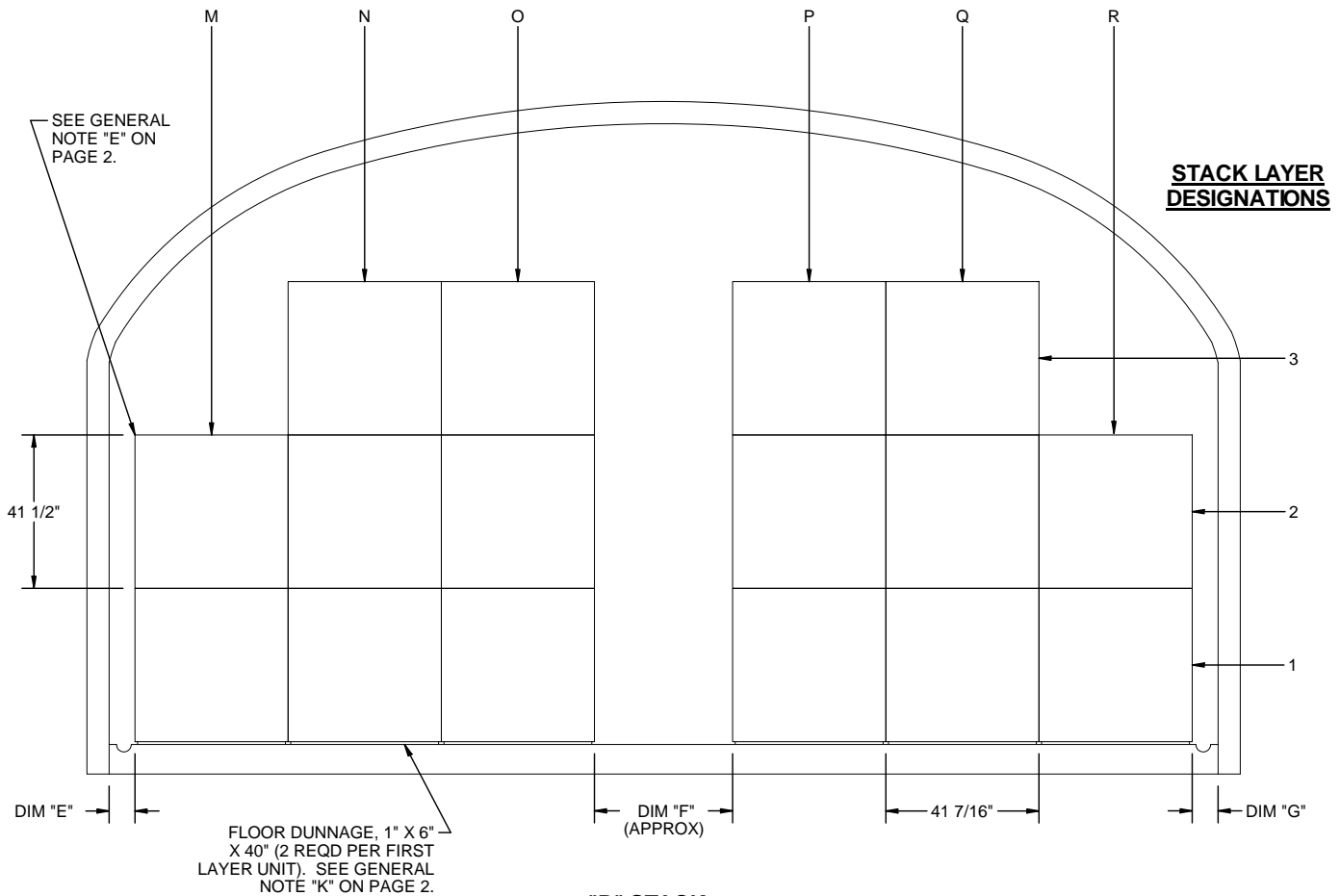

**"B" STACK**

(SEE "STACK IDENTIFICATION" ON PAGE 3 AND "CHART 2 - STACK CONFIGURATION" ON PAGE 7.)

**NOTE:** FOR IDENTIFICATION OF LETTERED DIMENSIONS REFER TO CHART 1 ON PAGE 6.

**STACK COLUMN DESIGNATIONS**

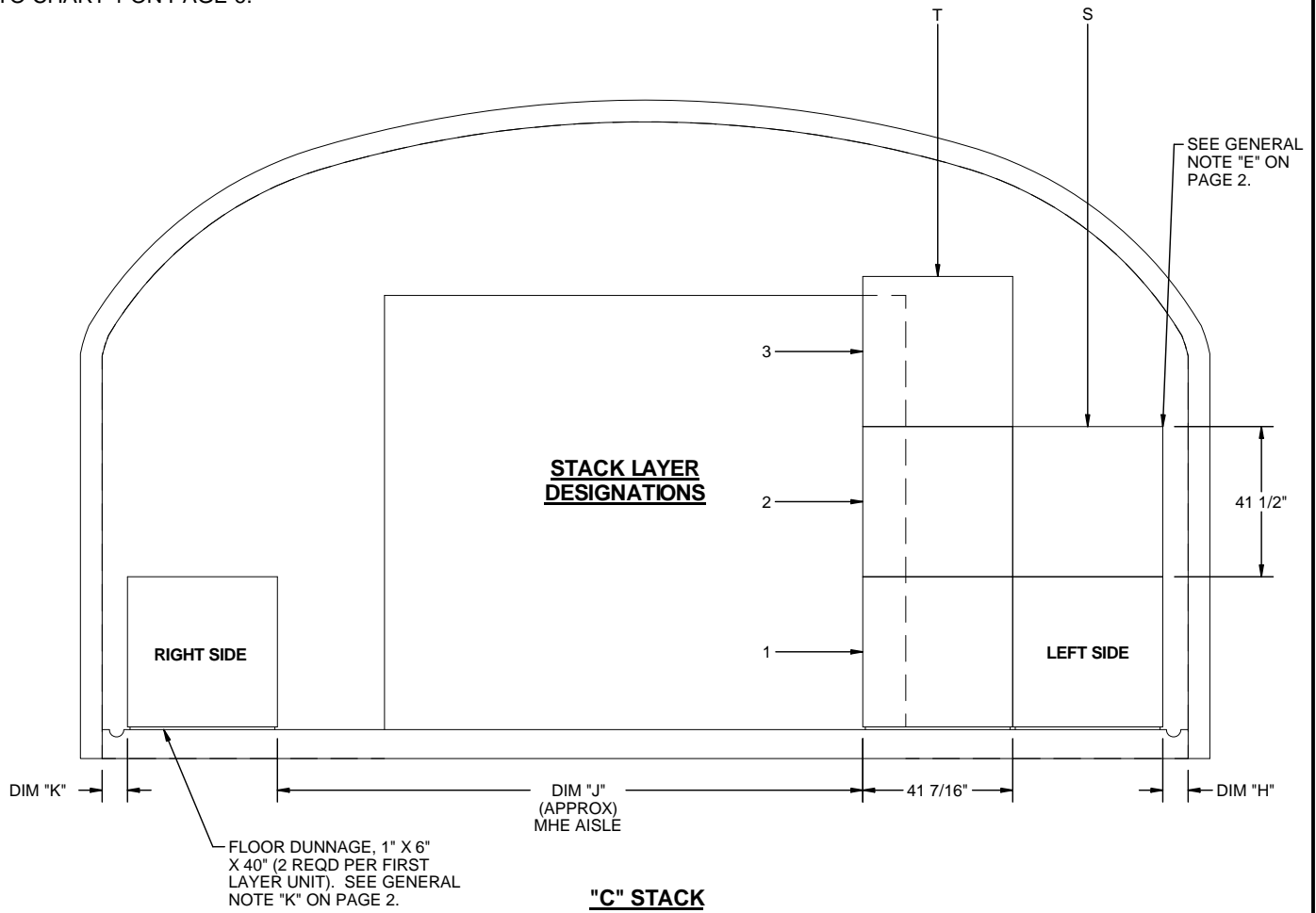

**"C" STACK**

TYPICAL "C" STACK FOR STRADLEY MAGAZINE.  
 (SEE "STACK IDENTIFICATION" ON PAGE 3 AND  
 "CHART 2 - STACK CONFIGURATION" ON PAGE 7)

ARROWS INDICATE END OF PALLET UNIT WITH HUMIDITY INDICATORS. SEE GENERAL NOTE "F" ON PAGE 2.

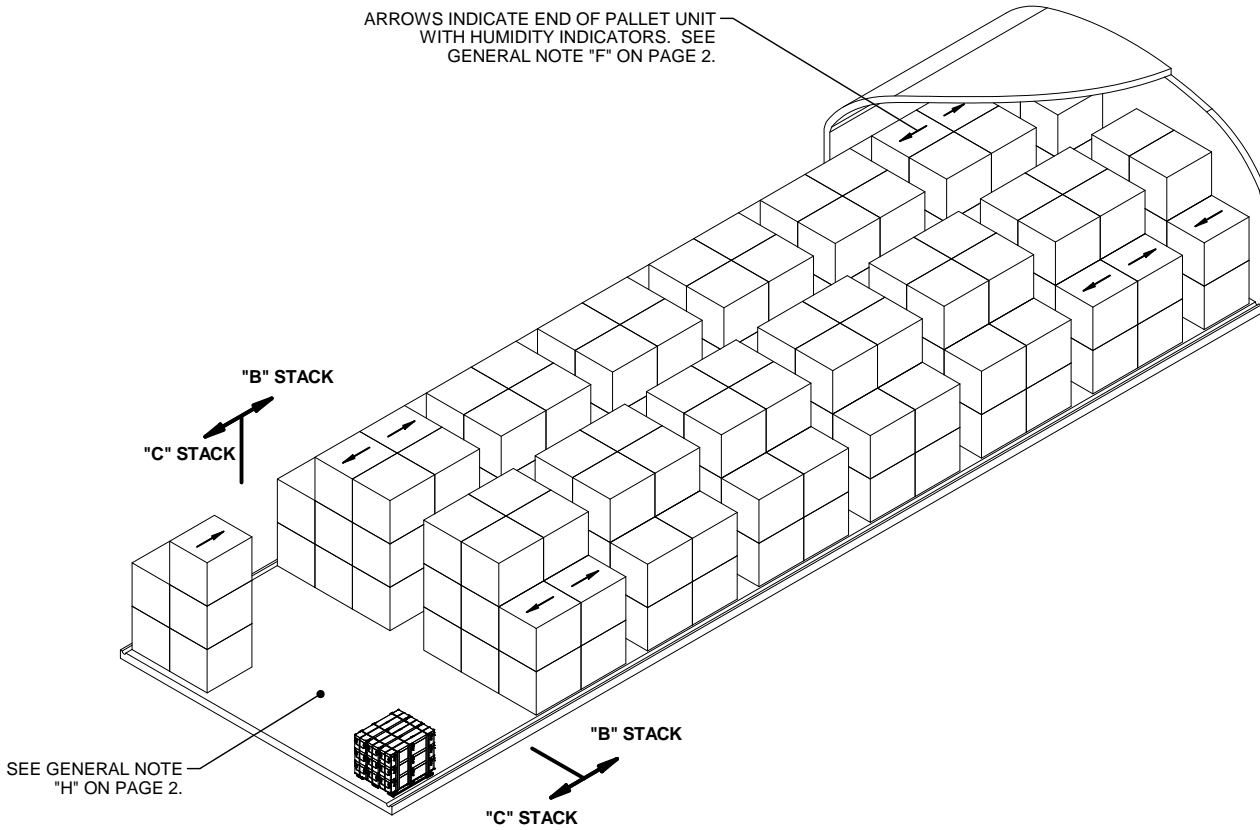

**ISOMETRIC VIEW**

STRADLEY MAGAZINE SHOWN AS TYPICAL.

**CHART 1 - DIMENSIONS**

MAGAZINE DIMENSIONS	MAGAZINE TYPE														
	IGLOO			ARCH 12'		ARCH 11'		ARCH 10'		OVAL ARCH	STRADLEY	STEEL ARCH			
LENGTH	40'-4"	60'-8"	81'-0"	26'-6"	81'-2"	40'-0"	80'-0"	40'-0"	80'-0"	40'-0"	80'-0"	89'-0"	80'-0"	59'-0"	89'-0"
WIDTH		26'-6"		26'-6"	25'-0"	25'-0"	25'-0"	25'-0"	25'-0"	24'-10"	25'-0"	25'-0"	25'-0"	24'-11"	
HEIGHT		12'-9"			12'-1-3/4"		11'-0"	10'-0"	14'-5"	14'-0"	14'-0"	14'-0"	14'-0"	13'-6"	
DIMENSIONS	CONTAINER SPACING DIMENSIONS														
DIM "D" (MHE AREA APPROX)	15'-2"	15'-0"	14'-10"	14'-4"	14'-10"	13'-2"	14'-2"	13'-2"	14'-10"	13'-10"	12'-7"	13'-10"	13'-4"	12'-7"	
DIM "E" ("B" STACK LEFT)	13"	13"	13"	17"	20"	20"	20"	20"	24"	24"	26"	7"	13"	6"	
DIM "F" ("B" STACK CENTER)	43"	43"	43"	35"	52"	52"	52"	52"	44"	44"	29"	37"	25"	38"	
DIM "G" ("B" STACK RIGHT)	13"	13"	13"	17"	20"	20"	20"	20"	24"	24"	8"	7"	13"	6"	
DIM "H" ("C" STACK LEFT)	13"	13"	13"	17"	20"	20"	20"	20"	24"	24"	26"	7"	23"	18"	
DIM "J" (MHE AISLE APPROX)	13'-11"	13'-11"	13'-11"	13'-3"	11'-3"	11'-3"	11'-3"	11'-3"	10'-8"	10'-8"	12'-9"	13'-5"	11'-7"	12'-6"	
DIM "K" ("C" STACK RIGHT)	13"	13"	13"	17"	20"	20"	20"	20"	24"	24"	8"	7"	13"	6"	
DIM "L" ("B" STACK BACK)	6"	6"	6"	14"	6"	14"	14"	14"	6"	6"	6"	6"	6"	6"	

## CHART 2 - STACK CONFIGURATION

MAGAZINE TYPE														
QUANTITY PER MAGAZINE	IGLOO			ARCH 12'	ARCH 12' X 25' W		ARCH 11'		ARCH 10'		OVAL ARCH	STRADLEY	STEEL ARCH	
	40'-4" L	60'-8" L	81'-0" L	26'-6" W	40'-0" L	80'-0" L	40'-0" L	80'-0" L	40'-0" L	80'-0" L	262	214	59'-0" L	89'-0" L
64	112	160	160	49	121	44	108	44	108	262	214	132	185	
<b>"B" STACK CONFIGURATION-LEFT SIDE</b>														
LAYER	CONTAINERS PER LAYER													
1	3(M-O)			3(M-O)	3(M-O)		3(M-O)		3(M-O)		3(M-O)	3(M-O)	3(M-O)	3(M-O)
2	2(N-O)			2(N-O)	2(N-O)		2(N-O)		2(N-O)		3(M-O)	3(M-O)	2(N-O)	2(N-O)
3	1(O)			1(O)	1(O)		0		0		3(M-O)	2(N-O)	2(N-O)	1(O)
SINGLE STACK TOTAL	6			6	6		5		5		9	8	7	6
NUMBER OF	5	9	13	13	5	13	5	13	5	13	15	13	9	15
<b>"B" STACK TOTAL</b>	30	54	78	78	30	78	25	65	25	65	135	104	63	90
<b>"B" STACK CONFIGURATION-RIGHT SIDE</b>														
LAYER	CONTAINERS PER LAYER													
1	3(P-R)			3(M-O)	2(P-Q)		2(P-Q)		2(P-Q)		3(P-R)	3(P-R)	3(P-R)	3(P-R)
2	2(P-Q)			2(N-O)	1(P)		1(P)		1(P)		3(P-R)	3(P-R)	2(P-Q)	2(P-Q)
3	1(R)			1(O)	0		0		0		2(P-Q)	2(P-Q)	2(P-Q)	1(P)
SINGLE STACK TOTAL	6			6	3		3		3		8	8	7	6
NUMBER OF	5	9	13	13	5	13	5	13	5	13	15	13	9	15
<b>"B" STACK TOTAL</b>	30	54	78	78	15	39	15	39	15	39	120	104	63	90
<b>"C" STACK CONFIGURATION - LEFT SIDE</b>														
LAYER	CONTAINERS PER LAYER													
1	2(S-T)			2(S-T)		2(S-T)		2(S-T)		2(S-T)	2(S-T)	2(S-T)	2(S-T)	
2	1(T)			1(T)		1(T)		1(T)		2(S-T)	2(S-T)	2(S-T)	1(T)	
3	0			0		0		0		2(S-T)	1(T)	1(T)	1(T)	
SINGLE STACK TOTAL	3			3		3		3		6	5	5	4	
NUMBER OF	1			1		1		1		1	1	1	1	
<b>"C" STACK LF TOTAL</b>	3			3		3		3		6	5	5	4	
<b>"C" STACK CONFIGURATION - RIGHT SIDE</b>														
<b>"C" STACK RT TOTAL</b>	1			1		1		1		1	1	1		

**SPECIAL NOTES:**

1. THE FOLLOWING NOTES, CHART 1 ON PAGE 6 AND CHART 2 ABOVE ARE PRESENTED AS GUIDANCE IN THE SELECTION OF A STORAGE PATTERN, AND IN DETERMINING THE QUANTITY OF PALLET UNITS WHICH CAN BE STORED IN THE STORAGE MAGAZINES LISTED IN THE CHARTS MENTIONED ABOVE.
2. CHART 1 ON PAGE 6 DESCRIBES THE STORAGE MAGAZINE GENERAL DIMENSIONS AND THE DIMENSIONS OF THE PALLET UNIT SPACING WITHIN THE STORAGE MAGAZINES.
3. DIMENSIONS "A", "B" AND "C" HAVE BEEN OMITTED TO AVOID CONFUSION WITH STACKS "A", "B" AND "C".
4. CHART 2 ABOVE DETAILS THE QUANTITY OF CONTAINERS IN EACH TYPE OF MAGAZINE AND THE LAYOUT OF THE STACKS FOR EACH TYPE OF MAGAZINE. THE CHART SHOWS THE NUMBER OF PALLET UNITS IN EACH STACK LAYER AND THE LOCATION OF THE PALLET UNIT ON EACH LAYER.

(CONTINUED AT RIGHT)

**EXAMPLE:**

CHART 2 - "C" STACK CONFIGURATION - LEFT SIDE  
MAGAZINE: STRADLEY

LAYER NUMBER 1: 2 (S-T)  
LAYER NUMBER 2: 2 (S-T)  
LAYER NUMBER 3: 1 (T)

**EXPLANATION:**

LAYER 1 (BOTTOM LAYER) HAS TWO PALLET UNITS FROM THE "S" COLUMN (NEAREST THE LEFT SIDE OF THE MAGAZINE) TO THE "T" COLUMN.

LAYER 2 (ON TOP OF LAYER 1) HAS TWO PALLET UNITS FROM THE "S" COLUMN (NEAREST THE LEFT SIDE OF THE MAGAZINE) TO THE "T" COLUMN.

LAYER 3 (ON TOP OF LAYER 2) HAS ONE PALLET UNIT AT THE "T" COLUMN.

**STORAGE IN 44'-7" MAGAZINE**

**STORAGE IN 52'-0" MAGAZINE**

**ITEM**                      **QUANTITY**  
 PALLET UNIT ----- 144

**ITEM**                      **QUANTITY**  
 PALLET UNIT ----- 216

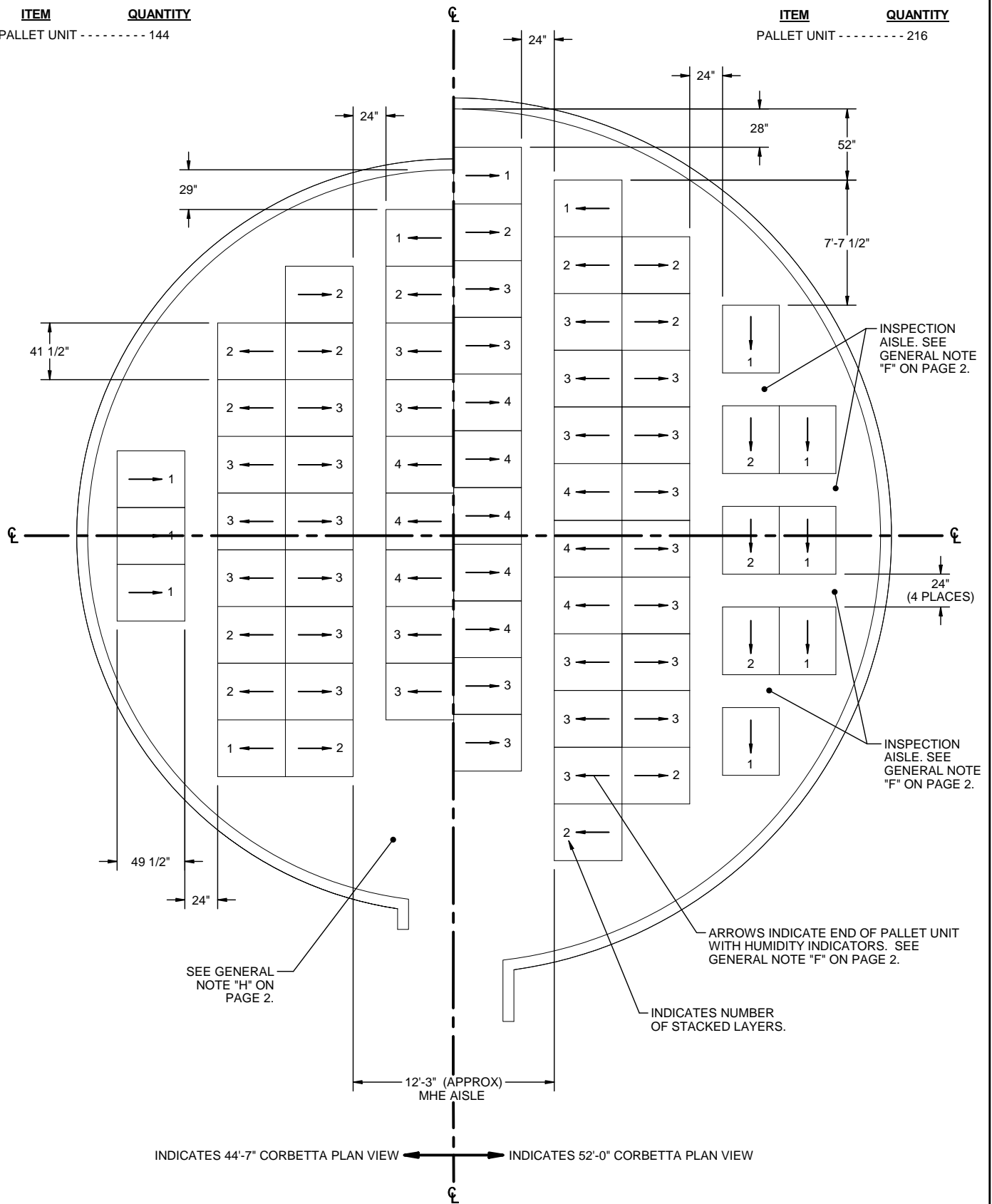

INDICATES 44'-7" CORBETTA PLAN VIEW ← → INDICATES 52'-0" CORBETTA PLAN VIEW

THE RIGHT HAND PLAN VIEW INDICATES A 52'-0" CORBETTA MAGAZINE, AND THE LEFT HAND PLAN VIEW INDICATES A 44'-7" CORBETTA MAGAZINE. BOTH SIZE MAGAZINE LAYOUTS ARE SYMMETRICAL AROUND THE VERTICAL CENTER LINE.

**CORBETTA MAGAZINE**



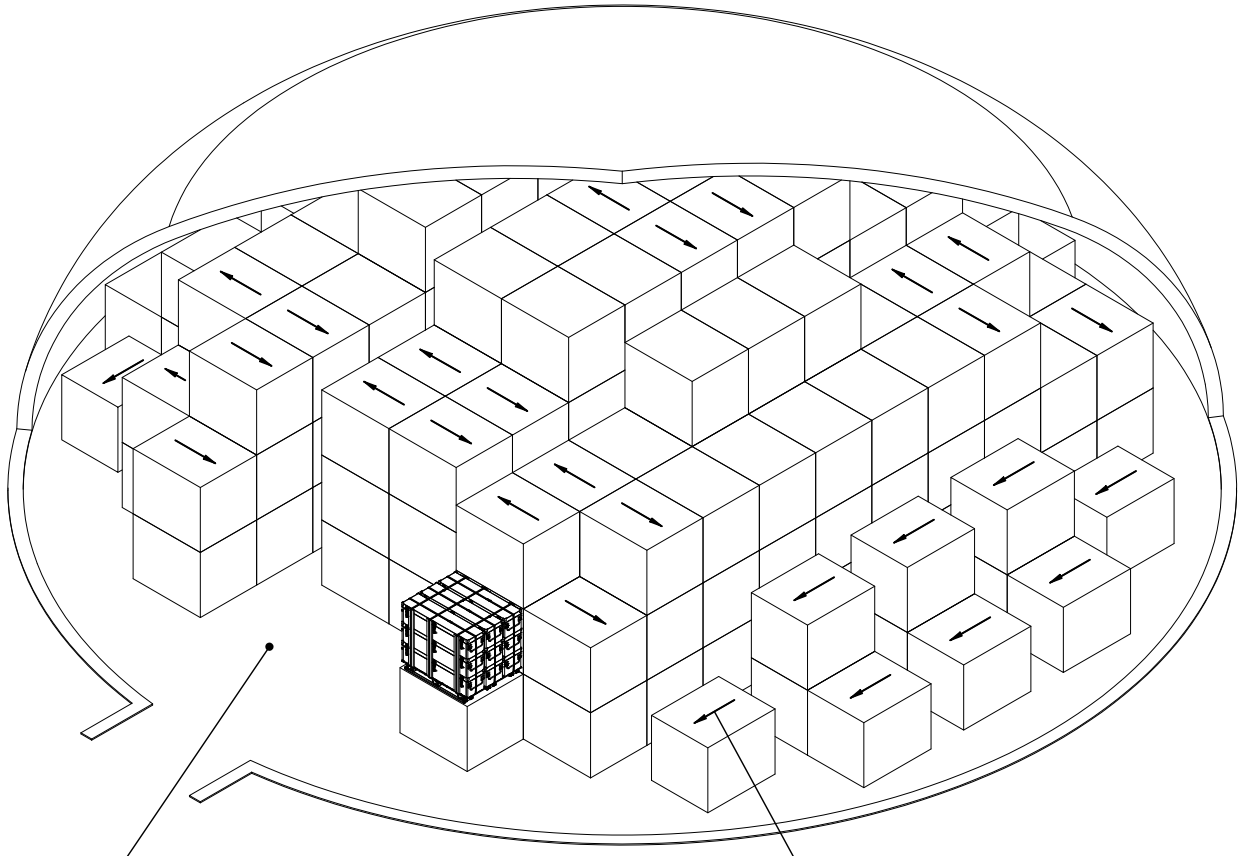

SEE GENERAL  
NOTE "H" ON  
PAGE 2.

ARROWS INDICATE END OF PALLET UNIT  
WITH HUMIDITY INDICATORS. SEE  
GENERAL NOTE "F" ON PAGE 2.

**ISOMETRIC VIEW**  
(52' - 0" DIA MAGAZINE)

**STORAGE IN RECTANGULAR  
MAGAZINE**

ITEM	QUANTITY
PALLET UNIT	----- 590

INSPECTION AISLE.  
SEE GENERAL NOTE  
"F" ON PAGE 2.

ARROWS INDICATE END OF PALLET UNIT  
WITH HUMIDITY INDICATORS. SEE  
GENERAL NOTE "F" ON PAGE 2.

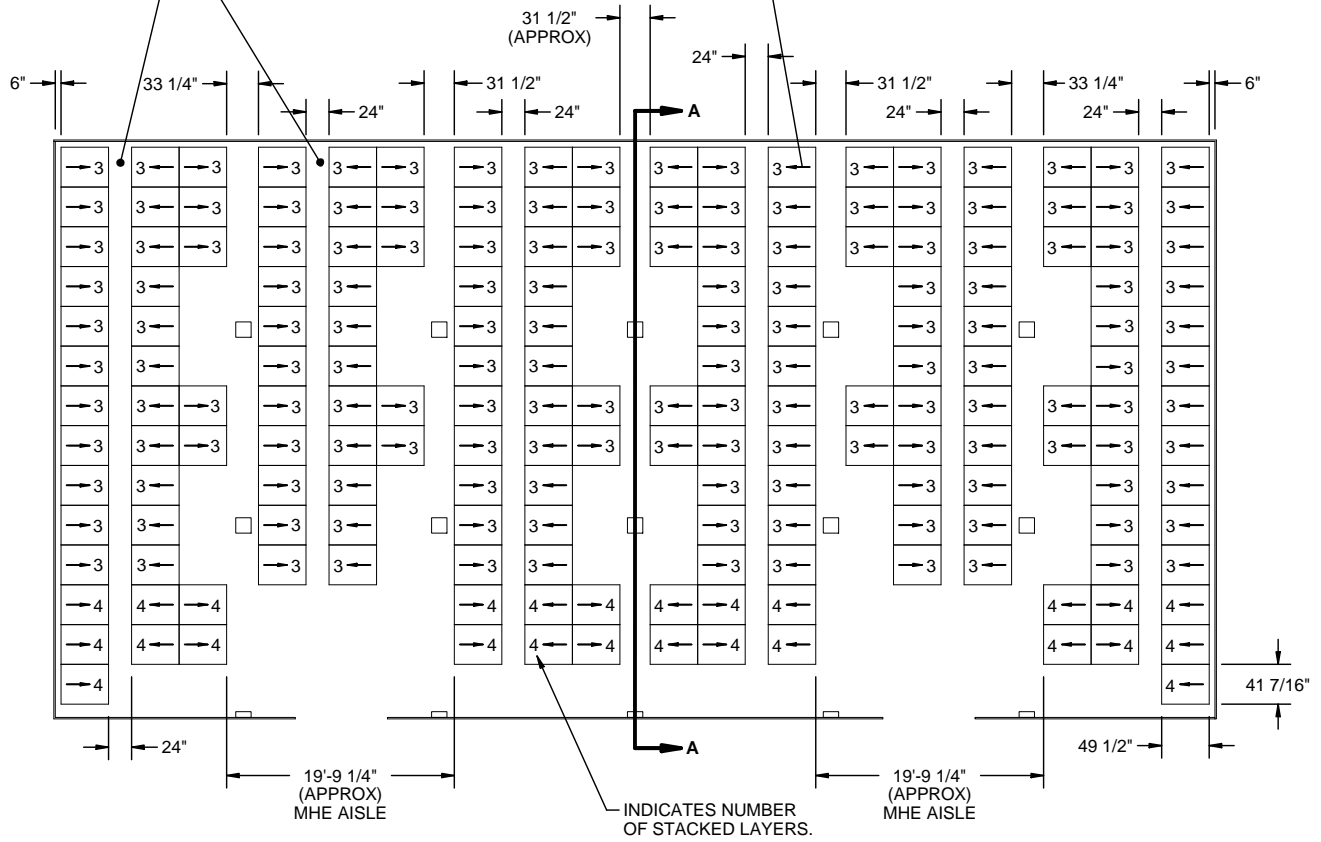

**PLAN VIEW**

SEE GENERAL NOTE  
"E" ON PAGE 2.

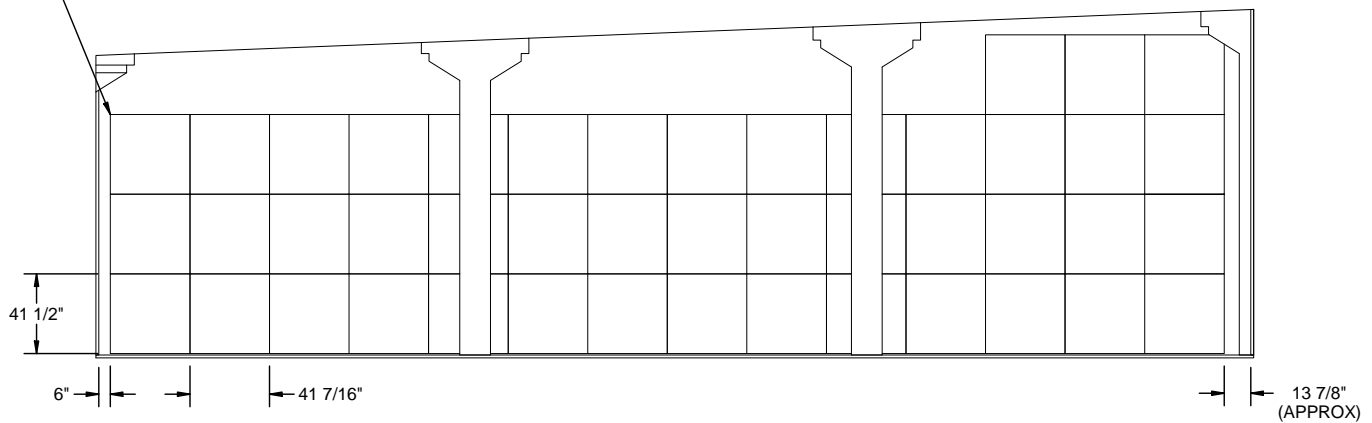

**SECTION A-A**

ARROWS INDICATE END OF PALLET UNIT  
WITH HUMIDITY INDICATORS. SEE  
GENERAL NOTE "F" ON PAGE 2.

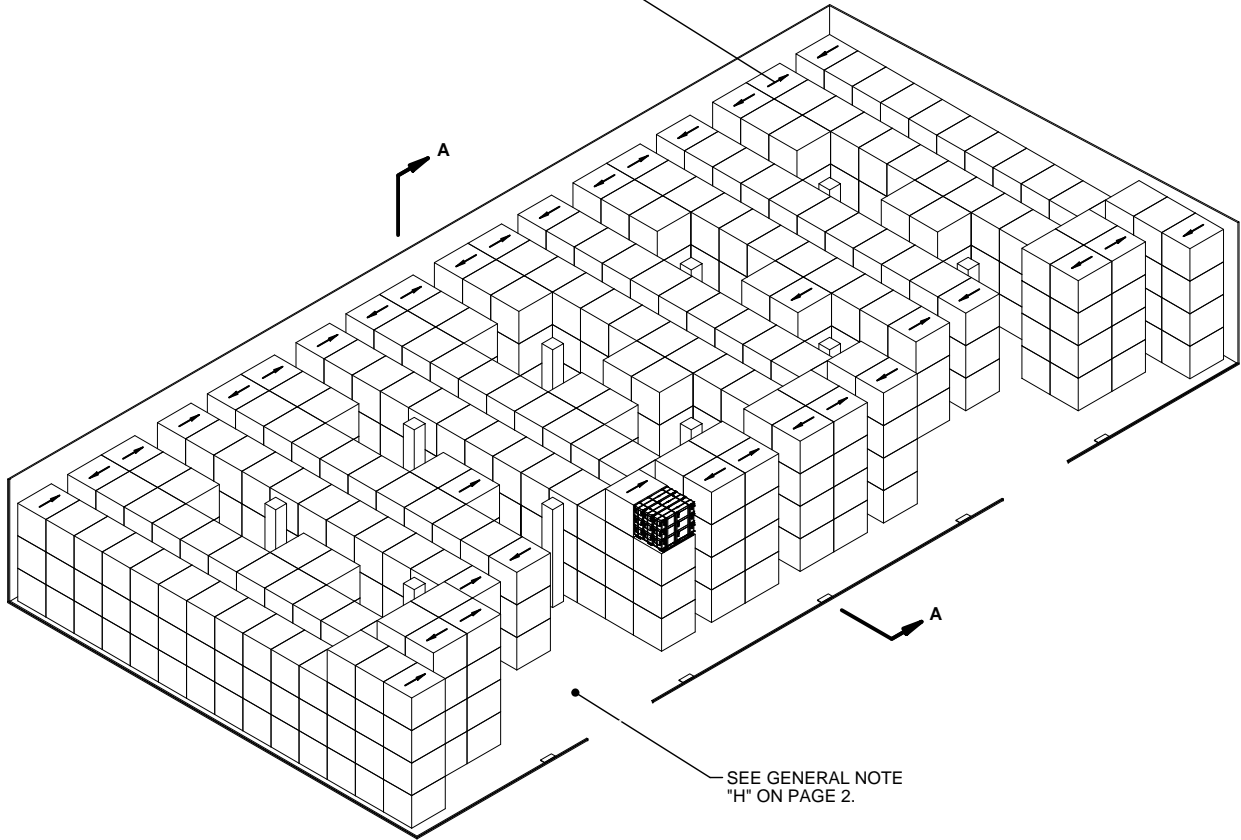

SEE GENERAL NOTE  
"H" ON PAGE 2.

**ISOMETRIC VIEW**

(50'-0" MAGAZINE)

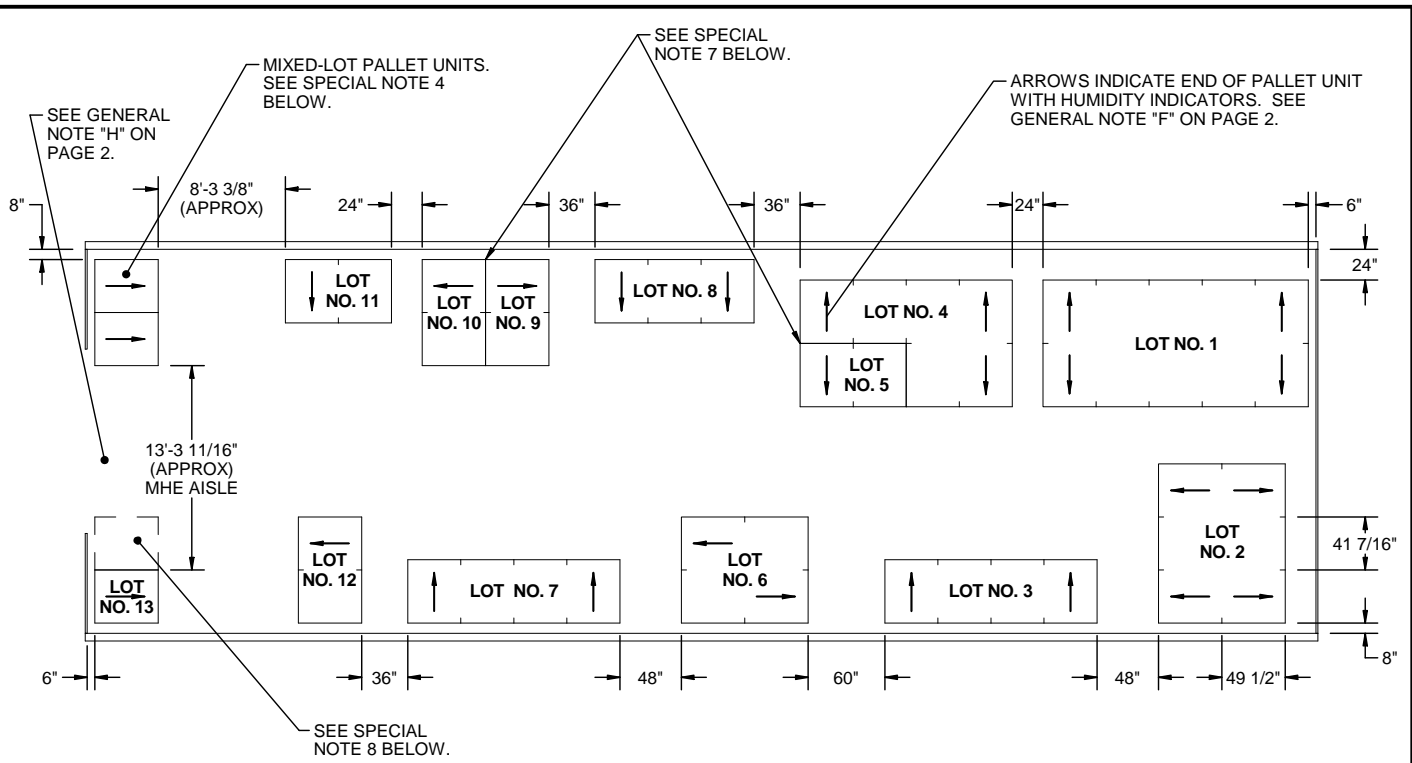

**PLAN VIEW**

**SPECIAL NOTES:**

1. THE STORAGE PLAN SHOWN IN THIS PAGE IS TYPICAL ONLY, AND APPLIES TO NUMEROUS LOTS. ADAPTATIONS MAY BE MADE AS REQUIRED TO ACCOMMODATE NUMBER AND SIZES OF LOTS TO BE STORED.
2. AN INSPECTION/INVENTORY AISLE NOT LESS THAN 24" WIDE MUST BE PROVIDED AT ONE SIDE OR END OF EACH LOT.
3. GENERALLY, THE LARGEST LOT SHOULD BE STORED IN THE REAR OR ON ONE SIDE OF THE MAGAZINE. HOWEVER, THESE AREAS MAY BE USED TO STORE MORE THAN ONE LOT BY ERECTING STACKS SIMILAR TO THOSE SHOWN IN THE FRONTAL AREA. AN MHE AISLE WILL BE REQUIRED ON ONE SIDE OF THE MAGAZINE, AND EACH LOT MUST BE ACCESSIBLE FOR REMOVAL AND INSPECTION/INVENTORY IN ACCORDANCE WITH OTHER CRITERIA SPECIFIED IN THESE SPECIAL NOTES AND IN THE GENERAL NOTES ON PAGE 2.
4. A MIXED-LOT PALLET UNIT MAY HAVE TWO LOTS PER PALLET UNIT UPWARD TO AS MANY DIFFERENT LOTS AS CONTAINERS WITHIN THAT UNIT. HOWEVER, BOTH LOTS WITHIN THE PALLET UNIT MUST HAVE THE SAME NATIONAL STOCK NUMBER AND CONDITION CODE.

(CONTINUED AT RIGHT)

**(SPECIAL NOTES CONTINUED)**

5. EACH LOT WITHIN THE MAGAZINE MUST BE ACCESSIBLE FOR MOVEMENT BY MHE. PALLET UNITS OF A SINGLE-LOT OR MIXED-LOT PALLET UNITS ARE CONSIDERED "ACCESSIBLE" IF NO MORE THAN 12 "LIFTS" OF ANOTHER LOT OR LOTS HAVE TO BE MADE TO GAIN ACCESS TO THE SINGLE-LOT OR MIXED-LOT PALLET. A "LIFT" MAY CONSIST OF ONE OR MORE PALLET UNITS, PROVIDING THE CAPACITY OF THE MHE PERMITS, AND SAFE HANDLING IS NOT JEOPARDIZED.
6. FOR STORAGE OF MULTIPLE LOTS, THE DISTANCE FROM THE SIDEWALL WILL BE BASED ON THE OVERHEAD CLEARANCE REQUIRED FOR MHE.
7. WHEN TWO LOTS ARE STORED ADJACENT TO EACH OTHER, THEY SHOULD BE SEPARATED BY AT LEAST 1" TO PROVIDE CLEARANCE FOR REMOVAL OF EITHER LOT.
8. THE MHE AISLE MAY BE USED TO STORE ONE OR MORE STACKS OF ADDITIONAL LOTS OR ADDITIONAL UNITS THAT ARE FROM A LOT ADJACENT TO THE MHE AISLE. ADEQUATE SPACE FROM MHE OPERATION MUST BE MADE AVAILABLE FOR THE ADDITIONAL STORAGE. ALSO, COMPLIANCE WITH ALL MULTIPLE-LOT CRITERIA AS SET FORTH ON THIS PAGE MUST BE OBSERVED.

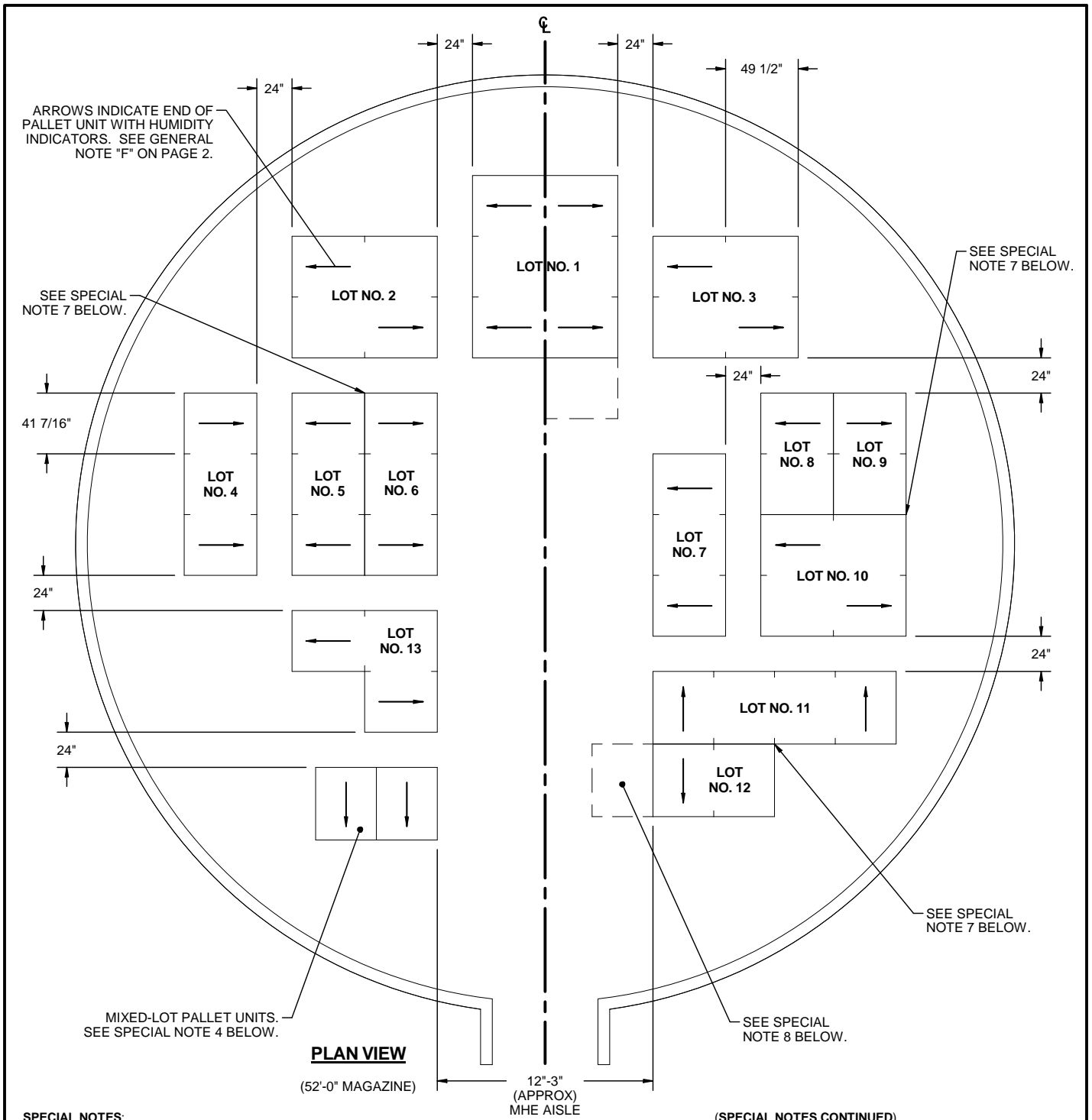

**SPECIAL NOTES:**

1. THE STORAGE PLAN SHOWN IN THIS PAGE IS TYPICAL ONLY, AND APPLIES TO NUMEROUS LOTS. ADAPTATIONS MAY BE MADE AS REQUIRED TO ACCOMMODATE NUMBER AND SIZES OF LOTS TO BE STORED.
2. AN INSPECTION/INVENTORY AISLE NOT LESS THAN 24" WIDE MUST BE PROVIDED AT ONE SIDE OR END OF EACH LOT.
3. GENERALLY, THE LARGEST LOT SHOULD BE STORED IN THE REAR OR ON ONE SIDE OF THE MAGAZINE. HOWEVER, THESE AREAS MAY BE USED TO STORE MORE THAN ONE LOT BY ERECTING STACKS SIMILAR TO THOSE SHOWN IN THE FRONTAL AREA. AN MHE AISLE WILL BE REQUIRED ON ONE SIDE OF THE MAGAZINE, AND EACH LOT MUST BE ACCESSIBLE FOR REMOVAL AND INSPECTION/INVENTORY IN ACCORDANCE WITH OTHER CRITERIA SPECIFIED IN THESE SPECIAL NOTES AND IN THE GENERAL NOTES ON PAGE 2.
4. A MIXED-LOT PALLET UNIT MAY HAVE TWO LOTS PER PALLET UNIT UPWARD TO AS MANY DIFFERENT LOTS AS CONTAINERS WITHIN THAT UNIT. HOWEVER, BOTH LOTS WITHIN THE PALLET UNIT MUST HAVE THE SAME NATIONAL STOCK NUMBER AND CONDITION CODE.

**(SPECIAL NOTES CONTINUED)**

5. EACH LOT WITHIN THE MAGAZINE MUST BE ACCESSIBLE FOR MOVEMENT BY MHE. PALLET UNITS OF A SINGLE-LOT OR MIXED-LOT PALLET UNITS ARE CONSIDERED "ACCESSIBLE" IF NO MORE THAN 12 "LIFTS" OF ANOTHER LOT OR LOTS HAVE TO BE MADE TO GAIN ACCESS TO THE SINGLE-LOT OR MIXED-LOT PALLET. A "LIFT" MAY CONSIST OF ONE OR MORE PALLET UNITS, PROVIDING THE CAPACITY OF THE MHE PERMITS, AND SAFE HANDLING IS NOT JEOPARDIZED.
6. FOR STORAGE OF MULTIPLE LOTS, THE DISTANCE FROM THE SIDEWALL WILL BE BASED ON THE OVERHEAD CLEARANCE REQUIRED FOR MHE.
7. WHEN TWO LOTS ARE STORED ADJACENT TO EACH OTHER, THEY SHOULD BE SEPARATED BY AT LEAST 1" TO PROVIDE CLEARANCE FOR REMOVAL OF EITHER LOT.
8. THE MHE AISLE MAY BE USED TO STORE ONE OR MORE STACKS OF ADDITIONAL LOTS OR ADDITIONAL UNITS THAT ARE FROM A LOT ADJACENT TO THE MHE AISLE. ADEQUATE SPACE FROM MHE OPERATION MUST BE MADE AVAILABLE FOR THE ADDITIONAL STORAGE. ALSO, COMPLIANCE WITH ALL MULTIPLE-LOT CRITERIA AS SET FORTH ON THIS PAGE MUST BE OBSERVED.

(CONTINUED AT RIGHT)

**TYPICAL MULTIPLE-LOT STORAGE IN CORBETTA MAGAZINE**

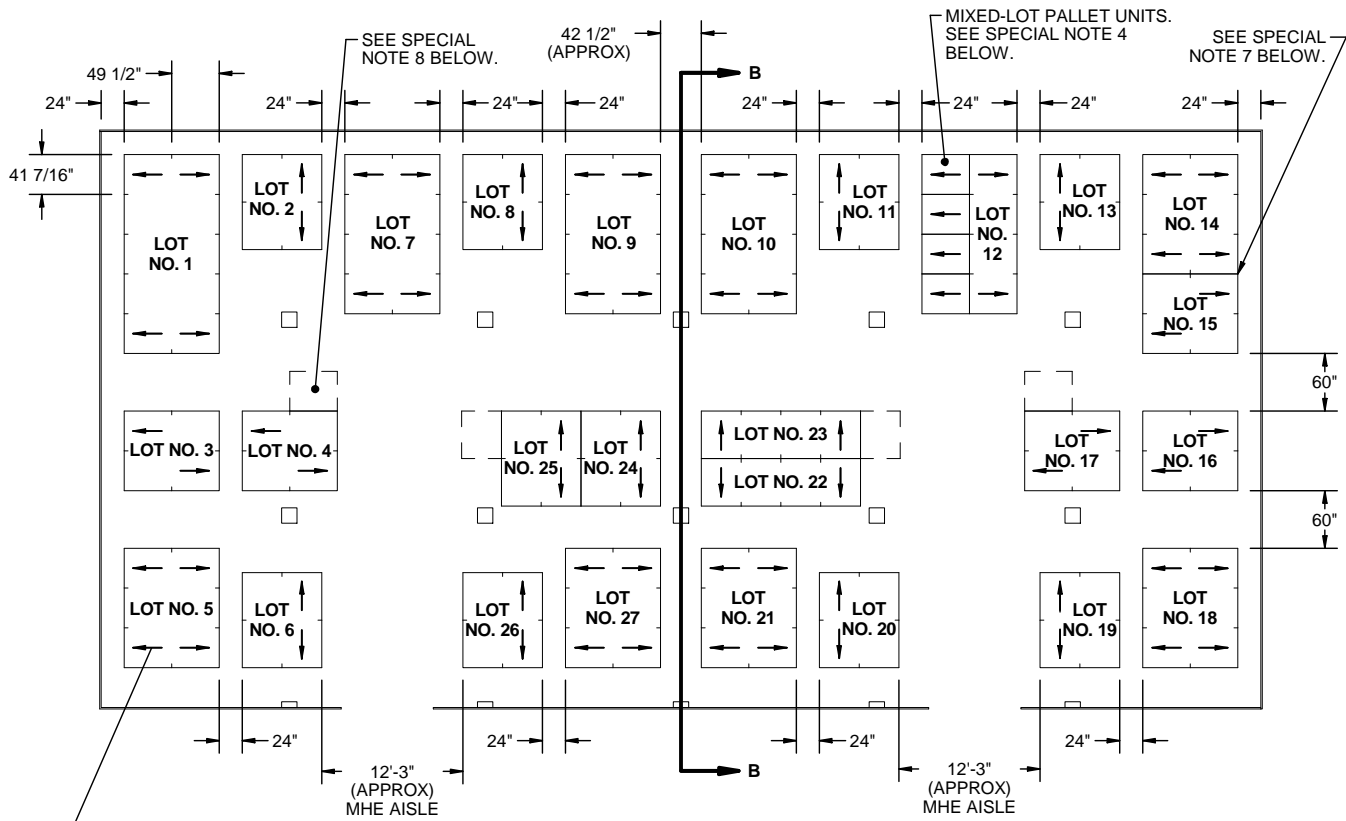

ARROWS INDICATE END OF PALLET UNIT WITH HUMIDITY INDICATORS. SEE GENERAL NOTE "F" ON PAGE 2.

**PLAN VIEW**

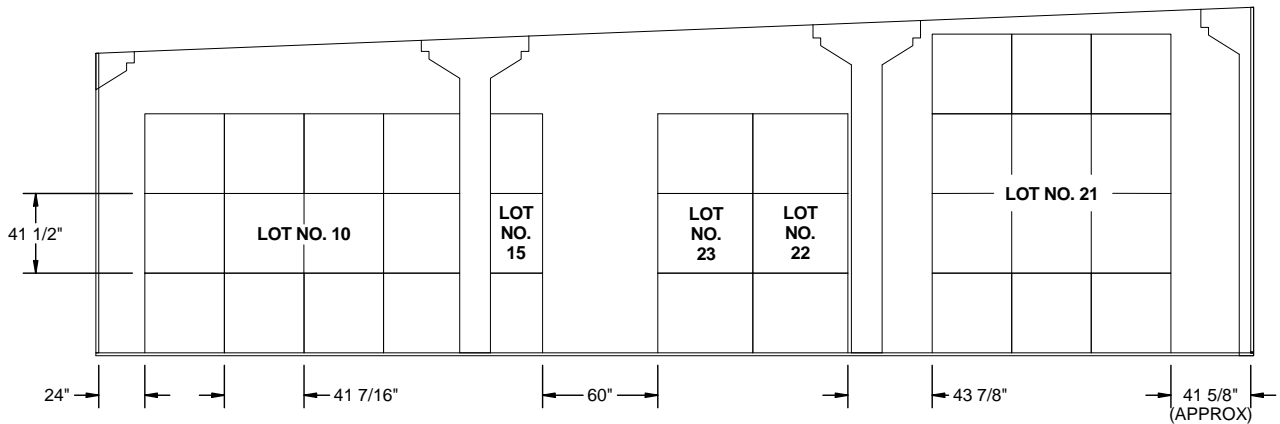

**SECTION B-B**

**SPECIAL NOTES**

1. THE STORAGE PLAN SHOWN IN THIS PAGE IS TYPICAL ONLY, AND APPLIES TO NUMEROUS LOTS. ADAPTATIONS MAY BE MADE AS REQUIRED TO ACCOMMODATE NUMBER AND SIZES OF LOTS TO BE STORED.
2. AN INSPECTION/INVENTORY AISLE NOT LESS THAN 24" WIDE MUST BE PROVIDED AT ONE SIDE OR END OF EACH LOT.
3. GENERALLY, THE LARGEST LOT SHOULD BE STORED IN THE REAR OR ON ONE SIDE OF THE MAGAZINE. HOWEVER, THESE AREAS MAY BE USED TO STORE MORE THAN ONE LOT BY ERECTING STACKS SIMILAR TO THOSE SHOWN IN THE FRONTAL AREA. AN MHE AISLE WILL BE REQUIRED ON ONE SIDE OF THE MAGAZINE, AND EACH LOT MUST BE ACCESSIBLE FOR REMOVAL AND INSPECTION/INVENTORY IN ACCORDANCE WITH OTHER CRITERIA SPECIFIED IN THESE SPECIAL NOTES AND IN THE GENERAL NOTES ON PAGE 2.
4. A MIXED-LOT PALLET UNIT MAY HAVE TWO LOTS PER PALLET UNIT UPWARD TO AS MANY DIFFERENT LOTS AS CONTAINERS WITHIN THAT UNIT. HOWEVER, BOTH LOTS WITHIN THE PALLET UNIT MUST HAVE THE SAME NATIONAL STOCK NUMBER AND CONDITION CODE.

**(SPECIAL NOTES CONTINUED)**

5. EACH LOT WITHIN THE MAGAZINE MUST BE ACCESSIBLE FOR MOVEMENT BY MHE. PALLET UNITS OF A SINGLE-LOT OR MIXED-LOT PALLET UNITS ARE CONSIDERED "ACCESSIBLE" IF NO MORE THAN 24 "LIFTS" OF ANOTHER LOT OR LOTS HAVE TO BE MADE TO GAIN ACCESS TO THE SINGLE-LOT OR MIXED-LOT PALLET. A "LIFT" MAY CONSIST OF ONE OR MORE PALLET UNITS, PROVIDING THE CAPACITY OF THE MHE PERMITS, AND SAFE HANDLING IS NOT JEOPARDIZED.
6. FOR STORAGE OF MULTIPLE LOTS, THE DISTANCE FROM THE SIDEWALL WILL BE BASED ON THE OVERHEAD CLEARANCE REQUIRED FOR MHE.
7. WHEN TWO LOTS ARE STORED ADJACENT TO EACH OTHER, THEY SHOULD BE SEPARATED BY AT LEAST 1" TO PROVIDE CLEARANCE FOR REMOVAL OF EITHER LOT.
8. THE MHE AISLE MAY BE USED TO STORE ONE OR MORE STACKS OF ADDITIONAL LOTS OR ADDITIONAL UNITS THAT ARE FROM A LOT ADJACENT TO THE MHE AISLE. ADEQUATE SPACE FROM MHE OPERATION MUST BE MADE AVAILABLE FOR THE ADDITIONAL STORAGE. ALSO, COMPLIANCE WITH ALL MULTIPLE-LOT CRITERIA AS SET FORTH ON THIS PAGE MUST BE OBSERVED.

(CONTINUED AT RIGHT)

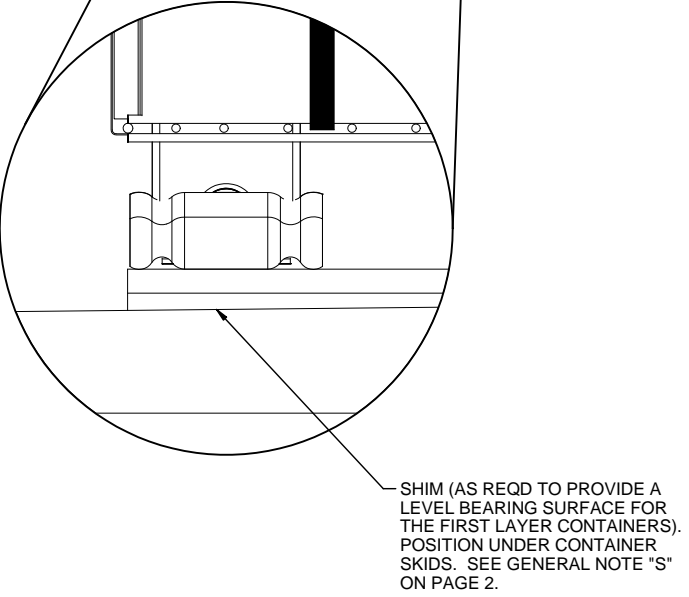
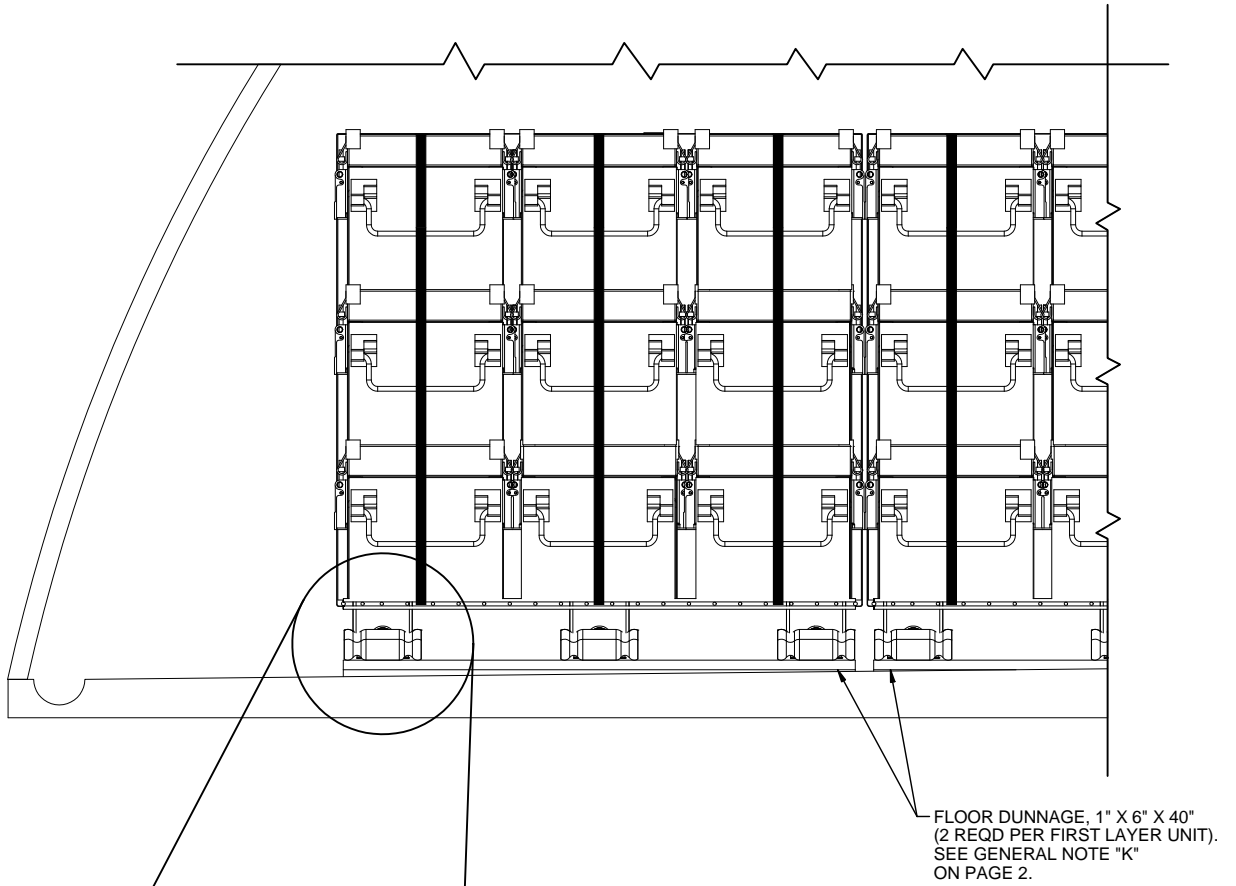

**FLOOR DUNNAGE AND SHIM LOCATION DETAILS**

