

APPROVED BY
BUREAU OF EXPLOSIVES

[Signature]

DATE 1-17-2008

LOADING AND BRACING* IN MILVAN[⊕] CONTAINERS OF BLU-122 BOMBS PACKED IN CNU-658 CONTAINERS



INDEX

ITEM	PAGE(S)
GENERAL NOTES AND MATERIAL SPECIFICATIONS - - - - -	2
SIX UNIT LOAD - - - - -	3
CONTAINER DETAILS - - - - -	4
DETAILS - - - - -	5-8
LESS-THAN-FULL-LOAD DETAILS - - - - -	6-7

⊕ ONLY MILVAN CONTAINERS WHICH HAVE BEEN MODIFIED TO INCLUDE A MECHANICAL LOAD BRACING SYSTEM THAT SATISFIES THE REQUIREMENTS OF THE BUREAU OF EXPLOSIVES PAMPHLET 6C WILL BE USED FOR THE MOVEMENT OF AMMUNITION BY T/COFC SERVICE. CAUTION: OTHER REQUIREMENTS OF PAMPHLET 6C ALSO APPLY.

* THE PROCEDURES SHOWN HEREIN ARE APPLICABLE TO LOADS THAT ARE TO BE SHIPPED BY TRAILER/CONTAINER-ON-FLATCAR (T/COFC) RAIL, MOTOR, OR WATER CARRIERS.

U.S. ARMY MATERIEL COMMAND DRAWING

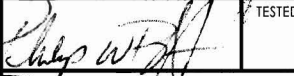
APPROVED, U.S. ARMY JOINT MUNITIONS COMMAND		<p>CAUTION: VERIFY PRIOR TO USE AT WWW.DAC.ARMY.MIL THAT THIS IS THE MOST CURRENT VERSION OF THIS DOCUMENT. THIS IS PAGE 1 OF 8.</p>					
		DO NOT SCALE		AUGUST 2007			
		ENGINEER OR TECHNICIAN	BASIC REV.	RICHARD GARSIDE			
<p>APPROVED BY ORDER OF COMMANDING GENERAL, U.S. ARMY MATERIEL COMMAND</p>  <p>U.S. ARMY DEFENSE AMMUNITION CENTER</p>		TRANSPORTATION ENGINEERING DIVISION					
		VALIDATION ENGINEERING DIVISION	TESTED	CLASS	DIVISION	DRAWING	FILE
		ENGINEERING DIRECTORATE			19	48	8853

GENERAL NOTES

- A. THIS DOCUMENT HAS BEEN PREPARED AND ISSUED IN ACCORDANCE WITH AR 740-1 AND AUGMENTS TM 743-200-1 (CHAPTER 5).
- B. THE SPECIFIED OUTLOADING PROCEDURES ARE APPLICABLE TO LOADS OF BLU-122 BOMBS PACKED IN CNU-658 CONTAINERS. SUBSEQUENT REFERENCE TO CONTAINER HEREIN MEANS CONTAINER WITH BOMB INSTALLED. SEE AIR FORCE DRAWING X20065101 AND PAGE 4 FOR DETAILS OF THE CONTAINER. CAUTION: REGARDLESS OF THE QUANTITY OF CONTAINERS TO BE SHIPPED, THE "MAXIMUM GROSS WEIGHT" OF THE MILVAN MUST NOT BE EXCEEDED.
- C. THE LOADS AS SHOWN ARE BASED ON A 20' LONG BY 8' WIDE BY 8' HIGH MILVAN WITH INSIDE DIMENSIONS OF 19'-4" LONG BY 92" WIDE BY 87" HIGH. THE LOADS ARE DESIGNED FOR TRAILER/CONTAINER-ON-FLATCAR (T/COFC) SHIPMENT.
- D. THE SPECIFIED OUTLOADING PROCEDURES ARE FOR CONTAINERS EQUIPPED WITH SELP-CONTAINED MECHANICAL BRACING DEVICES AS DESCRIBED IN MIL-C-52661. CROSS MEMBER ATTACHMENT FACILITIES WITHIN THESE CONTAINERS MUST PROVIDE FOR THE INSTALLATION OF LOAD BLOCKING CROSS MEMBERS AT THE HEIGHTS SPECIFIED. VOIDS LENGTHWISE WITHIN THE LOADS MUST BE HELD TO A MINIMUM. CROSS MEMBERS MUST BE PLACED AGAINST THE LADING AS TIGHTLY AS THE HOLE SPACING IN THE CROSS MEMBER ATTACHMENT FACILITY PERMITS. SEE THE "FILL DETAIL" ON PAGE 5 FOR ADDITIONAL GUIDANCE. EACH CROSS MEMBER WILL BE INSTALLED WITH THE ENDS ATTACHED AS NEARLY AS POSSIBLE IN "MATED" POSITIONS (AT EQUAL HEIGHTS, AND AT EQUAL DISTANCES FROM THE END OF THE CONTAINER). CROSS MEMBERS IN EMPTY CONTAINERS AND THOSE NOT USED IN LOADED CONTAINERS MUST BE FASTENED INTO BELT RAILS FOR SHIPMENT. COMPONENTS ASSIGNED TO EACH CONTAINER MUST REMAIN THEREWITH EVEN THOUGH UNUSED DURING SOME SHIPMENTS. THE LOAD BLOCKING COMPONENT DESIGNATED AS "CROSS MEMBER" HEREIN IS IDENTIFIED AS "BEAM ASSEMBLY" WITHIN TM 55-8115-200-23&P, DATED DECEMBER 1979. THE BEAM ASSEMBLY IS FURTHER IDENTIFIED AS NSN 8115-00-165-6623.
- E. WHEN LOADING CONTAINERS, THEY ARE TO BE POSITIONED SO AS TO ACHIEVE A TIGHT LOAD (TIGHT AGAINST THE DUNNAGE ASSEMBLIES). THE UNLOCKED SPACE ACROSS THE WIDTH OF A LOAD BAY IS NOT TO EXCEED 1-1/2". EXCESSIVE SLACK CAN BE ELIMINATED FROM A LOAD BY LAMINATING ADDITIONAL PIECES OF APPROPRIATE THICKNESS TO THE HORIZONTAL PIECES ON THE FILLER ASSEMBLIES. NAIL EACH ADDITIONAL PIECE W/1 APPROPRIATELY SIZED NAIL EVERY 12". ADDITIONALLY, THE LENGTH OF THE STRUTS IN THE FILLER ASSEMBLIES MAY BE ADJUSTED AS REQUIRED TO FACILITATE VARIANCE IN THE SIZE OF THE CONTAINERS.
- F. DUNNAGE LUMBER SPECIFIED IS OF NOMINAL SIZE. FOR EXAMPLE, 1" X 4" MATERIAL IS ACTUALLY 3/4" THICK BY 3-1/2" WIDE AND 2" X 6" MATERIAL IS ACTUALLY 1-1/2" THICK BY 5-1/2" WIDE.
- G. A STAGGERED NAILING PATTERN WILL BE USED WHENEVER POSSIBLE WHEN NAILS ARE DRIVEN INTO JOINTS OF DUNNAGE ASSEMBLIES OR WHEN LAMINATING DUNNAGE. ADDITIONALLY, THE NAILING PATTERN FOR AN UPPER PIECE OF LAMINATED DUNNAGE WILL BE ADJUSTED AS REQUIRED SO THAT A NAIL FOR THAT PIECE WILL NOT BE DRIVEN THROUGH, ON TO, OR RIGHT BESIDE A NAIL IN A LOWER PIECE.
- H. CAUTION: DO NOT NAIL DUNNAGE MATERIAL TO THE MILVAN WALLS OR FLOOR. ALL NAILING WILL BE WITHIN THE DUNNAGE.
- J. PORTIONS OF THE MILVAN DEPICTED WITHIN THIS DRAWING, SUCH AS ONE OF THE SIDEWALLS, HAVE NOT BEEN SHOWN IN THE LOAD VIEWS FOR CLARITY PURPOSES.
- K. TO MAKE LOADING EASIER, TO HELP ACHIEVE A TIGHT LOAD ACROSS A CONTAINER, AND TO PREVENT UNACCEPTABLE DAMAGE TO LADING UNITS WHEN LOADING A MILVAN, A SLIP-SHEET CAN BE USED EFFECTIVELY AS A "SHOEHORN" TYPE DEVICE. THE SLIP-SHEET WILL PROVIDE A SMOOTH SURFACE THAT WILL PREVENT CONTAINERS FROM INTERLOCKING OR CATCHING ON OTHER PROJECTIONS WHEN LATERALLY ADJACENT LADING UNITS ARE BEING LOADED. A SLIP-SHEET WILL BE USED AFTER TWO-THIRDS OF A STACK IS LOADED WITH ITS SIDES IN TIGHT CONTACT AT THE SIDES OF THE MILVAN. THE SLIP-SHEETS ARE TO BE PLACED AGAINST THE OTHER SIDES OF THE STACK BEFORE THE LAST THIRD OF THE STACK IS LOADED. AFTER A STACK IS COMPLETED, THE SLIP-SHEETS ARE TO BE REMOVED. A SLIP-SHEET OF SUITABLE SIZE CAN BE MADE FROM A SHEET OF 1/8" TEMPERED HARDBOARD (MASONITE) OR FROM A SHEET OF ANY OTHER MATERIAL THAT WILL SATISFY THE REQUIREMENTS.
- L. THE MAXIMUM LOAD WEIGHTS ARE CONTROLLED BY EQUIPMENT CAPABILITY FACTORS. ALTHOUGH THE HEAVIEST MAXIMUM LOADS ARE DELINEATED IN THE LOAD VIEWS, PROVISIONS ARE INCLUDED WITHIN THIS DRAWING SO THAT THE BASIC LOADS CAN BE ADJUSTED TO SATISFY A LESSER QUANTITY OF LADING UNITS. DEPENDING ON TRANSPORTATION ROUTING, IT MAY BE NECESSARY TO REDUCE THE LOAD WEIGHT TO SATISFY "WEIGHT LAWS" OF CERTAIN STATES. ALSO, IT MAY BE NECESSARY TO REDUCE THE LOAD WEIGHT TO SATISFY OTHER WEIGHT RESTRICTIONS IMPOSED ON THE INTERMODAL CONTAINER SYSTEM.

(CONTINUED AT RIGHT)

(GENERAL NOTES CONTINUED)

- M. REQUIREMENTS CITED WITHIN THE ASSOCIATION OF AMERICAN RAILROADS (AAR) INTERMODAL LOADING GUIDE APPLY WHEN THE SHIPMENT MOVES BY TRAILER/CONTAINER-ON-FLATCAR (T/COFC). SPECIAL T/COFC NOTES FOLLOW:
1. A LOADED CONTAINER MUST BE ON A CHASSIS EQUIPPED WITH TWO BOGEY ASSEMBLIES WHEN BEING MOVED IN TOFC SERVICE, REGARDLESS OF THE LOAD WEIGHT WITHIN THE CONTAINER.
 2. LOAD LIMITS OF T/COFC RAIL CARS MUST NOT BE EXCEEDED, NOR WILL A CAR BE LOADED SO THAT THE TRUCK UNDER ONE END OF THE CAR CARRIES MORE THAN ONE-HALF OF THE LOAD LIMIT FOR THAT CAR.
 3. CHASSIS/CONTAINERS COUPLED INTO A 40-FOOT TRAILER CONFIGURATION MUST BE PLACED AT THE B-END OF A TOFC RAIL CAR. THE REAR END OF THE 40-FOOT UNIT WILL OVERHANG THE END OF THE CAR IF IT IS PLACED AT THE A-END. TWENTY-FOOT AND 40-FOOT UNITS CAN BE LOADED ON THE SAME CAR.
- N. DURING INTRASTATE AND/OR INTERSTATE MOVES BY MOTOR CARRIER, A PROPER CHASSIS OR MODIFIED FLATBED TRAILER MUST BE USED TO PRECLUDE VIOLATION OF ONE OR MORE "WEIGHT LAWS" APPLICABLE TO THE STATE OR STATES INVOLVED.
- O. CONVERSION TO METRIC EQUIVALENTS: DIMENSIONS WITHIN THIS DOCUMENT ARE EXPRESSED IN INCHES AND WEIGHTS ARE EXPRESSED IN POUNDS. WHEN NECESSARY, THE METRIC EQUIVALENTS MAY BE COMPUTED ON THE BASIS OF ONE INCH EQUALS 25.4MM AND ONE POUND EQUALS 0.454 KG.
- P. WHETHER A CONTAINER IS FULL OR IS LOADED WITH A REDUCED QUANTITY OF LADING UNITS, THE LENGTHWISE CENTER OF GRAVITY OF THE LOAD MUST BE WITHIN 12", IN EITHER DIRECTION, OF THE MID-POINT OF THE CONTAINER.
- Q. THE QUANTITY OF CONTAINERS SHOWN IN THE LOAD ON PAGE 3 MAY BE REDUCED FOR SHIPMENT, IF DESIRED. SEE THE DETAILS ON PAGES 6 AND 7.
- R. AS REQUIRED BY THE ASSOCIATION OF AMERICAN RAILROADS (AAR), ALL 1-1/4" AND 2" STEEL STRAPPING USED FOR LOAD RESTRAINT MUST BE MARKED AS SPECIFIED WITHIN THE APPLICABLE AAR RULES GOVERNING LOADING, BLOCKING AND BRACING OF FREIGHT WITHIN THE CONVEYANCE. FOR THE SPECIFIC MARKING SIZE, FREQUENCY, ETC., REQUIRED, REFER TO THE APPROPRIATE AAR LOADING RULES.
- S. ANTI-CHAFING MATERIAL MAY BE INSTALLED AT POINTS OF CONTACT BETWEEN CONTAINERS, BETWEEN CONTAINERS AND MILVAN, AND BETWEEN CONTAINERS AND STEEL STRAPPINGS, IF DESIRED, TO PREVENT CHAFING DAMAGE TO CONTAINER PAINT AND MARKINGS.
- T. WHEN STEEL STRAPPING IS SEALED AT AN END-OVER-END LAP JOINT, A MINIMUM OF ONE SEAL WITH TWO PAIR OF NOTCHES WILL BE USED TO SEAL THE JOINT WHEN A NOTCH-TYPE SEALER IS BEING USED. A MINIMUM OF TWO SEALS, BUTTED TOGETHER, WITH TWO PAIR OF CRIMPS PER SEAL WILL BE USED TO SEAL THE JOINT WHEN A CRIMP-TYPE SEALER IS BEING USED. REFER TO THE "STRAP JOINT A" AND "STRAP JOINT B" DETAILS ON PAGE 6 FOR GUIDANCE.

MATERIAL SPECIFICATIONS

- LUMBER - - - - - : SEE TM 743-200-1 (DUNNAGE LUMBER) AND VOLUNTARY PRODUCT STANDARD PS 20.
- NAILS - - - - - : ASTM F1667; COMMON STEEL NAIL (NLCMS OR NLCMMS).
- PLYWOOD - - - - - : COMMERCIAL ITEM DESCRIPTION A-A-55057, INDUSTRIAL PLYWOOD, INTERIOR WITH EXTERIOR GLUE, GRADE C-D. IF SPECIFIED GRADE IS NOT AVAILABLE, A BETTER INTERIOR OR AN EXTERIOR GRADE MAY BE SUBSTITUTED.
- STRAPPING, STEEL - - : ASTM D3953; FLAT STRAPPING, TYPE 1, HEAVY DUTY, FINISH A, B (GRADE 2), OR C.
- SEAL, STRAP - - - - : ASTM D3953; CLASS H, FINISH A, B (GRADE 2), OR C, DOUBLE NOTCH TYPE, STYLE I, II, OR IV.
- WIRE, CARBON STEEL - : ASTM A853; ANNEALED AT FINISH, BLACK OXIDE FINISH, 0.0800" DIA, GRADE 1006 OR BETTER.
- ANTI-CHAFING MATERIAL - - - - - : MIL-PRF-121 (OR EQUAL); NEUTRAL BARRIER MATERIAL.

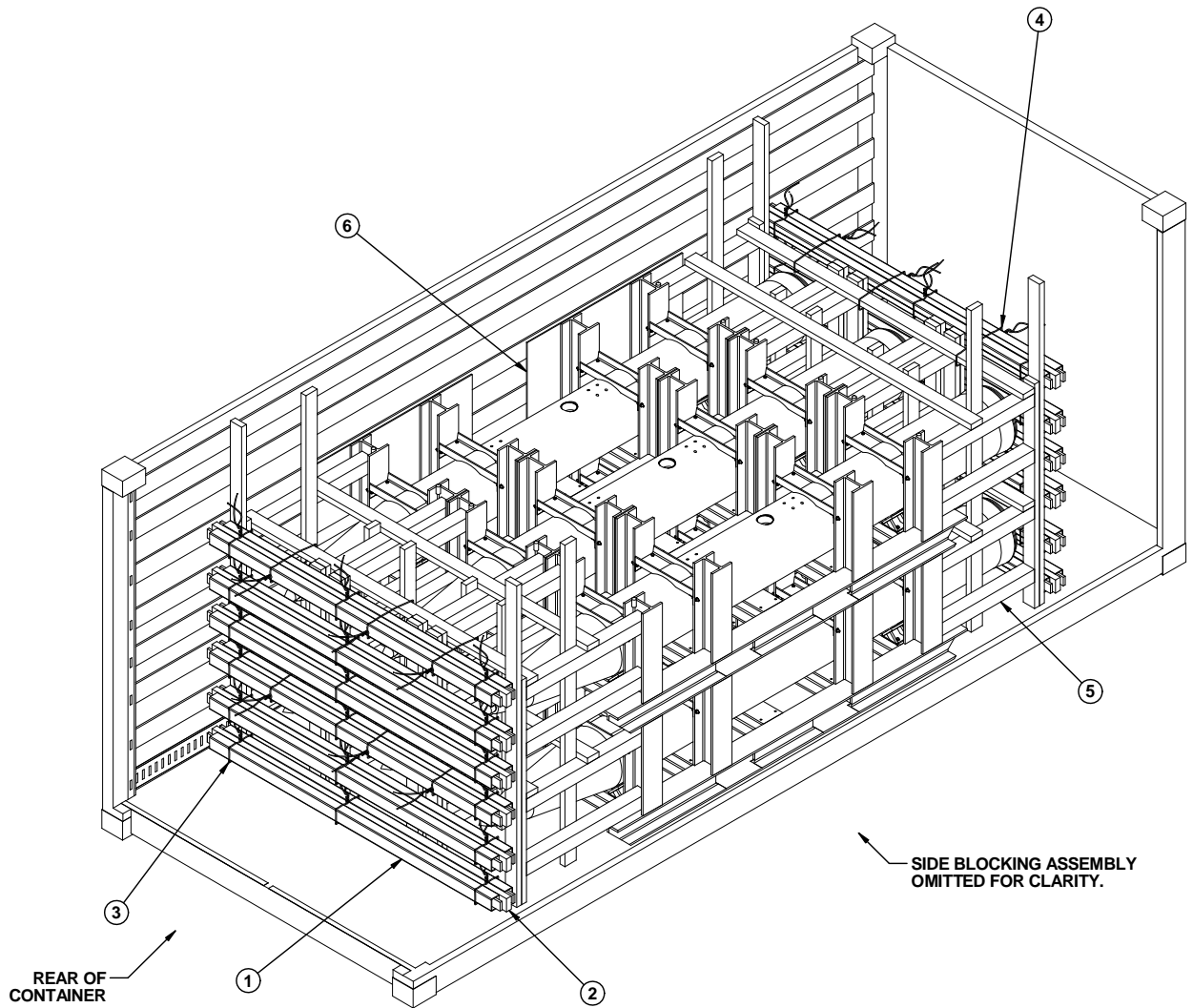

ISOMETRIC VIEW

KEY NUMBERS

- ① CROSS MEMBER (24 REQD). POSITION AS SHOWN IN THE DETAIL ABOVE, AT THE 5", 16", 28", 38", 48" AND 60" HEIGHTS.
- ② FILL MATERIAL, 1-3/8" (ACTUAL) X 4" BY INSIDE CONTAINER WIDTH MINUS 1" (REF: 7'-7") (12 REQD). SEE THE "FILL DETAIL" ON PAGE 5.
- ③ TIE WIRE, 0.0800" DIAMETER WIRE BY 24" LONG (36 REQD). INSTALL TO FORM A COMPLETE LOOP AROUND FILL MATERIAL AND CROSS MEMBERS, BRING ENDS TOGETHER AND TWIST TAUT. SECURE TO THE FILL MATERIAL WITH A PARTIALLY DRIVEN 10d NAIL BENT OVER THE WIRE, OR WITH A STRAP STAPLE.
- ④ TIE WIRE, 0.0800" DIAMETER WIRE BY 36" LONG (12 REQD). INSTALL TO FORM A COMPLETE LOOP AROUND FILL MATERIAL, CROSS MEMBERS, AND HORIZONTAL STRUT BRACING, BRING ENDS TOGETHER AND TWIST TAUT. SECURE TO THE FILL MATERIAL WITH A PARTIALLY DRIVEN 10d NAIL BENT OVER THE WIRE, OR WITH A STRAP STAPLE.
- ⑤ STRUT ASSEMBLY (2 REQD). SEE THE DETAIL ON PAGE 5.
- ⑥ SIDE BLOCKING ASSEMBLY (4 REQD). SEE THE DETAIL ON PAGE 8.

BILL OF MATERIAL

LUMBER	LINEAR FEET	BOARD FEET
2" X 4"	264	176
4" X 4"	140	187
NAI LS	NO. REQD	POUNDS
6d (2")	32	1/4
10d (3")	492	7-3/4
PLYWOOD, 1/4"	80 SQ FT REQD	55 LBS
WI RE, 0.0800" DIA	108' REQD	2 LBS
CROSS MEMBER	24 REQD	

LOAD AS SHOWN

ITEM	QUANTITY	WEIGHT (APPROX)
CNU-658	6	29,490 LBS
DUNNAGE		790 LBS
CONTAINER		5,700 LBS
TOTAL WEIGHT		35,980 LBS

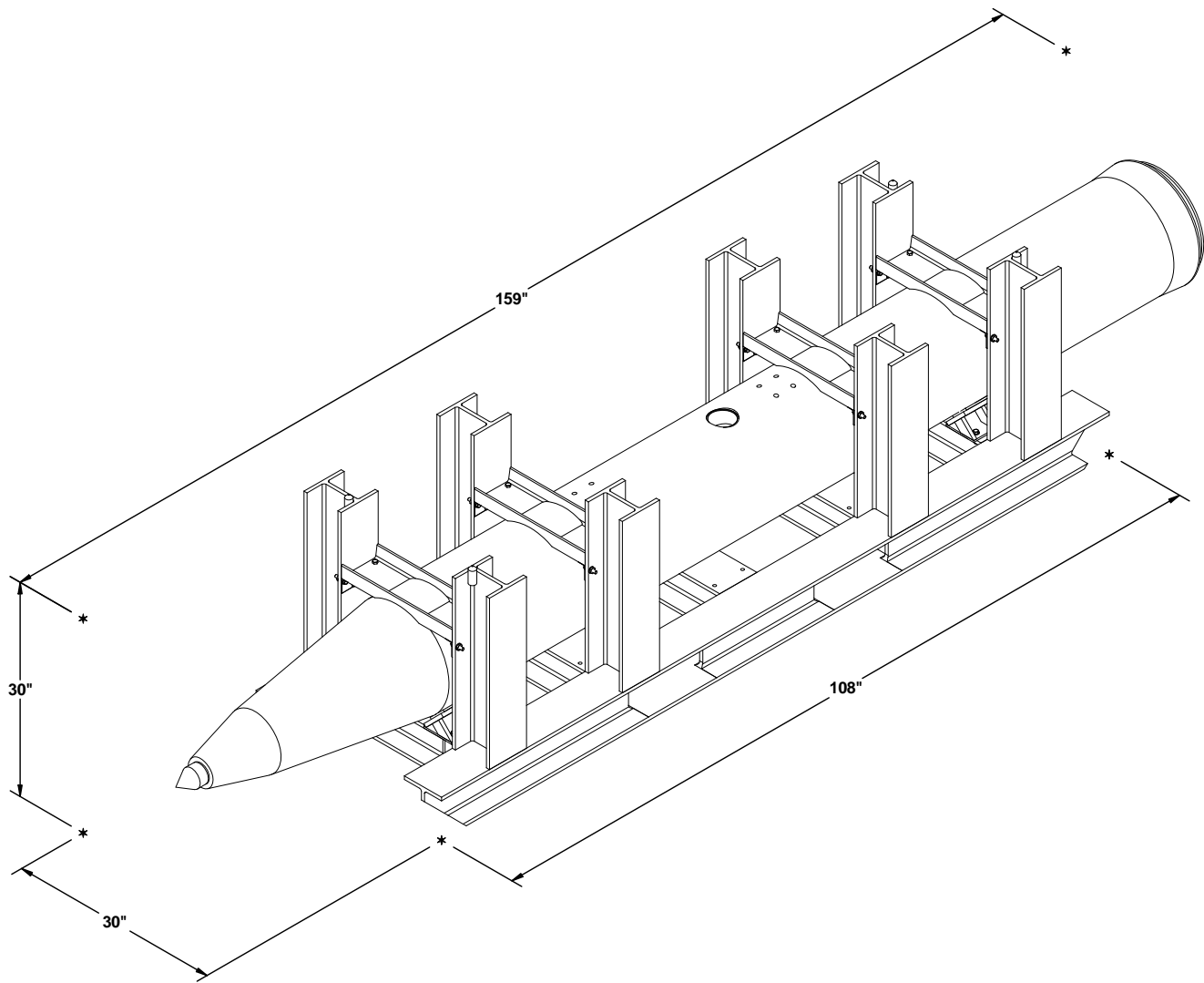

CNU-658 CONTAINER

GROSS WEIGHT - - - - - 4,915 LBS (APPROX)
 CUBE - - - - - 82.8 CU FT (APPROX)

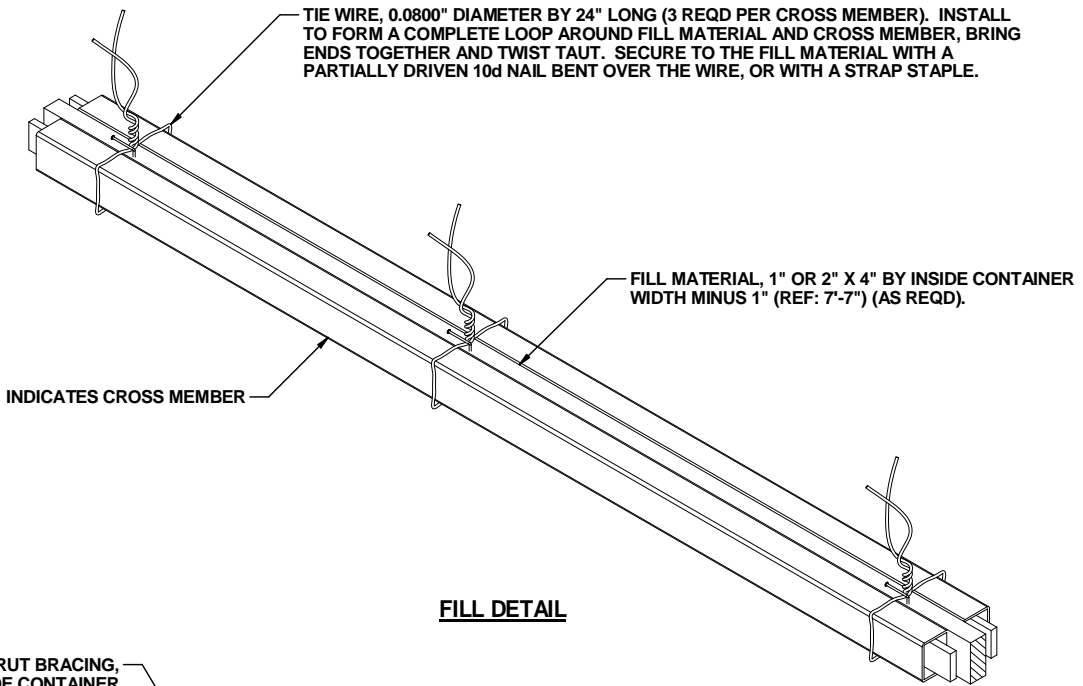

FILL DETAIL

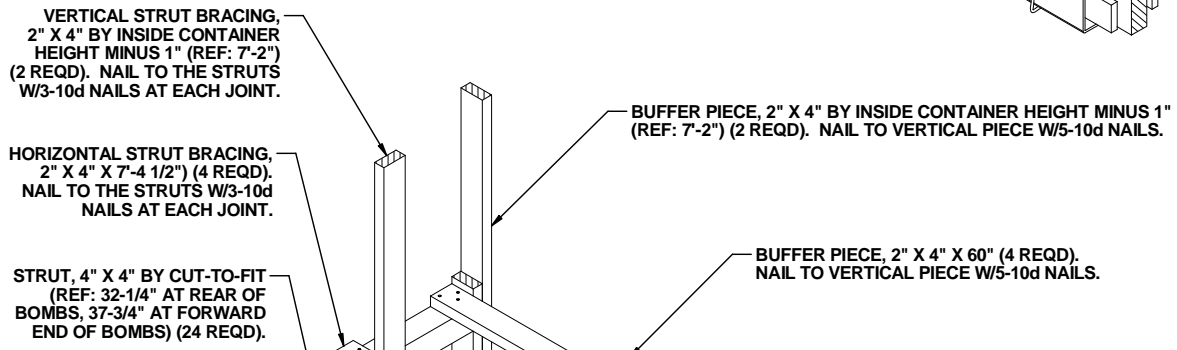

VERTICAL STRUT BRACING,
2" X 4" X 60" (4 REQD). NAIL
TO THE STRUTS W/3-10d
NAILS AT EACH JOINT.

VERTICAL PIECE, 2" X 4" X 60" (6 REQD).
NAIL TO THE STRUTS W/2-12d NAILS
AT EACH JOINT.

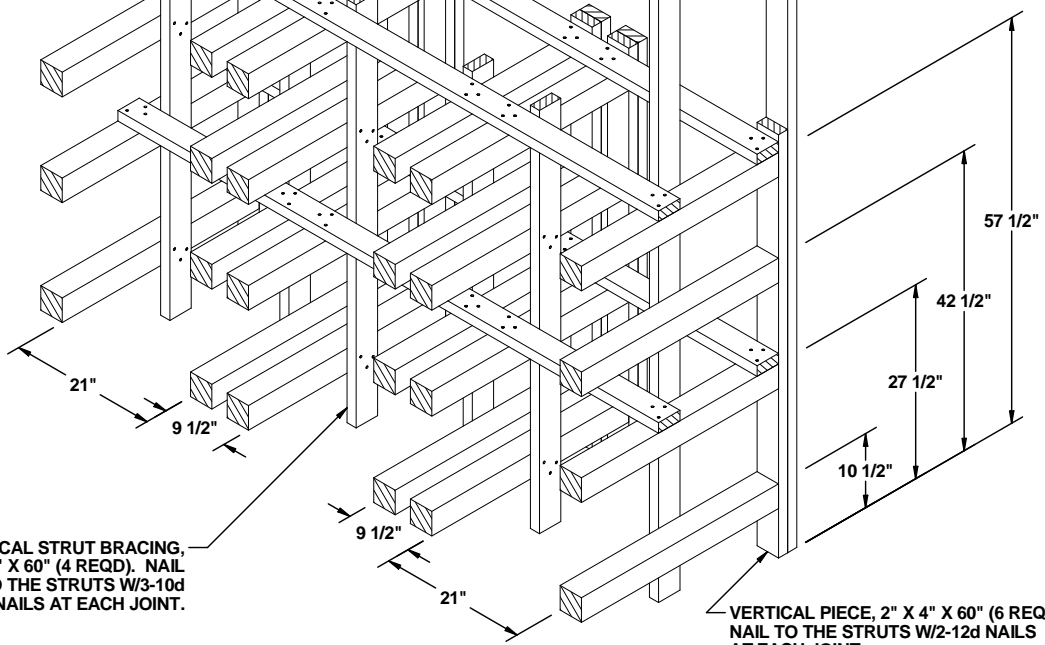

STRUT ASSEMBLY

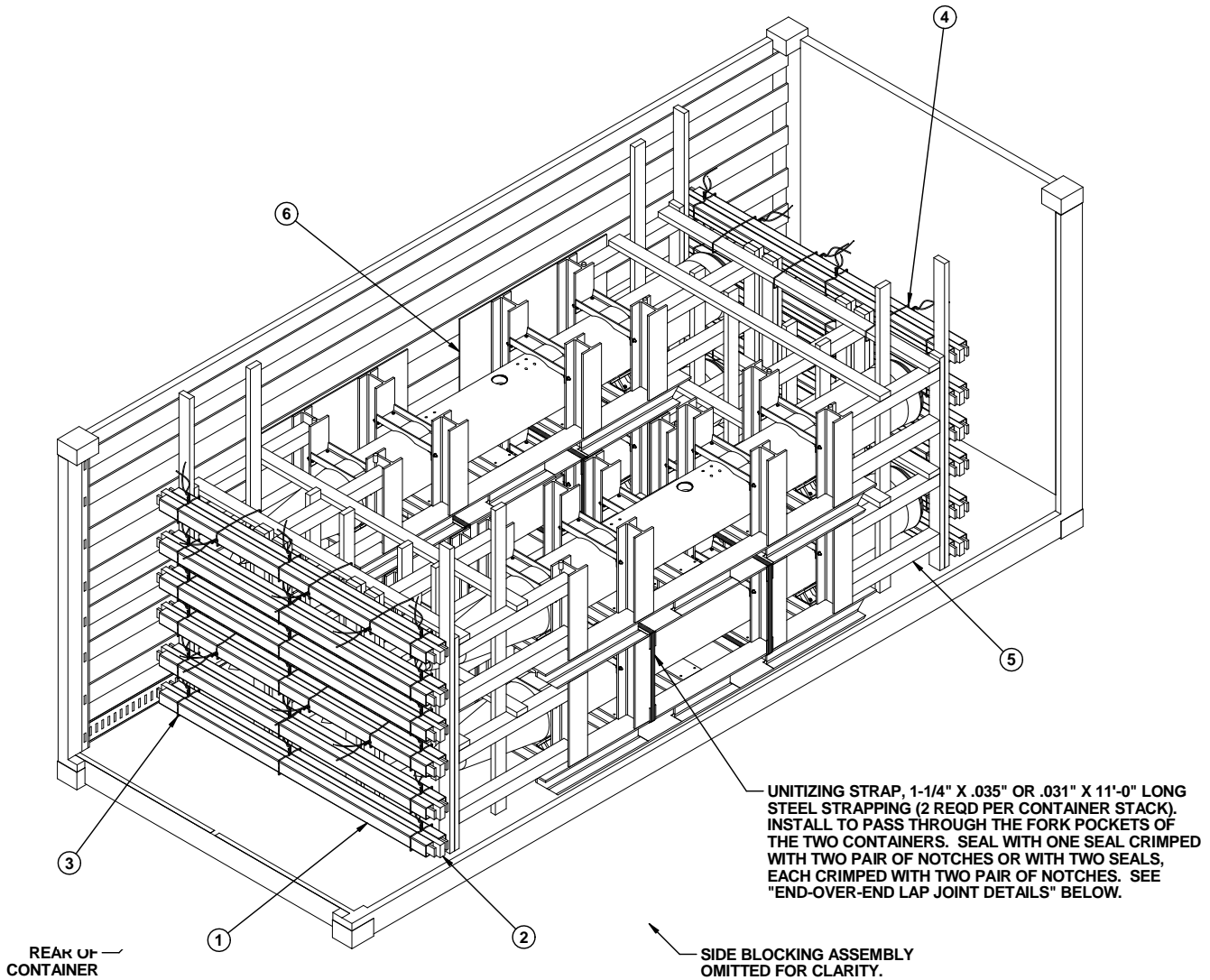

SPECIAL NOTE:

WHEN REDUCING A LOAD BY ONE OR MORE CONTAINERS, IT WILL BE NECESSARY TO UNITIZE THE CONTAINER STACK(S) WHICH IS(ARE) LATERALLY ADJACENT TO THE OMITTED CONTAINER AS DEPICTED IN THE LOAD VIEW ABOVE. SEE GENERAL NOTES "P" AND "R" ON PAGE 2.

LESS-THAN-FULL-LOAD PROCEDURE

KEY NUMBERS REFER TO KEY NUMBERS ON PAGE 3.



ONE SEAL WITH TWO PAIR OF NOTCHES.

STRAP JOINT A

METHOD OF SECURING A STRAP JOINT WHEN USING A NOTCH-TYPE SEALER.



TWO SEALS, BUTTED TOGETHER, WITH TWO PAIR OF CRIMPS EACH SEAL.

STRAP JOINT B

METHOD OF SECURING A STRAP JOINT WHEN USING A CRIMP-TYPE SEALER.

END-OVER-END LAP JOINT DETAILS

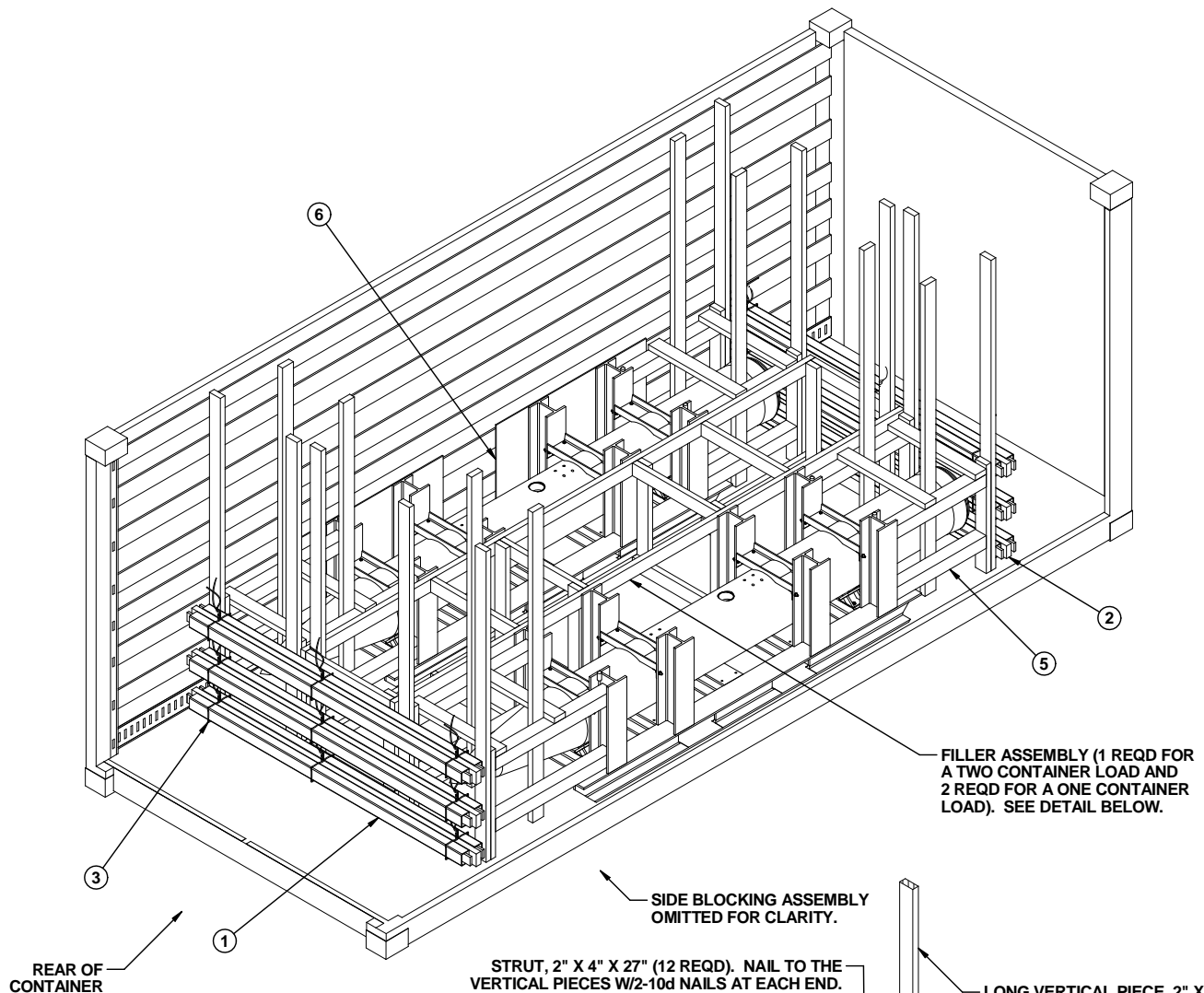

LESS-THAN-FULL-LOAD PROCEDURE

KEY NUMBERS REFER TO KEY NUMBERS ON PAGE 3.
SEE GENERAL NOTE "P" ON PAGE 2.

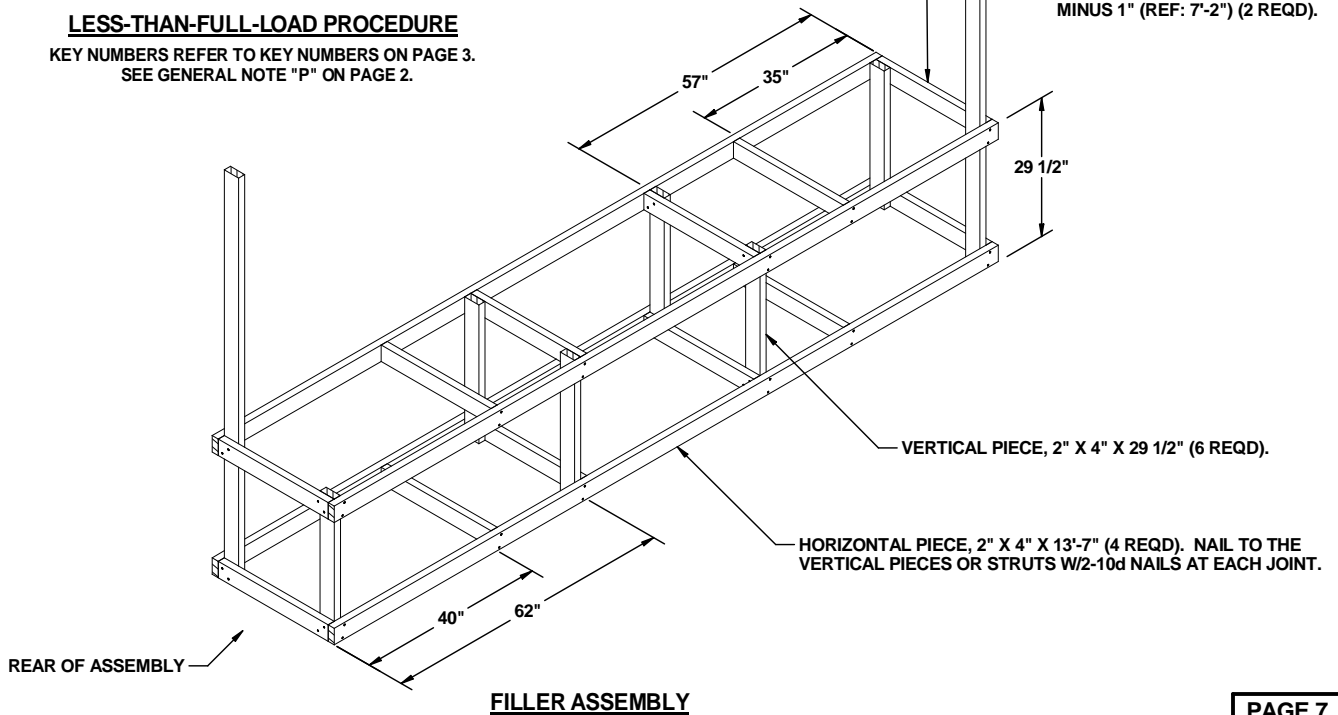

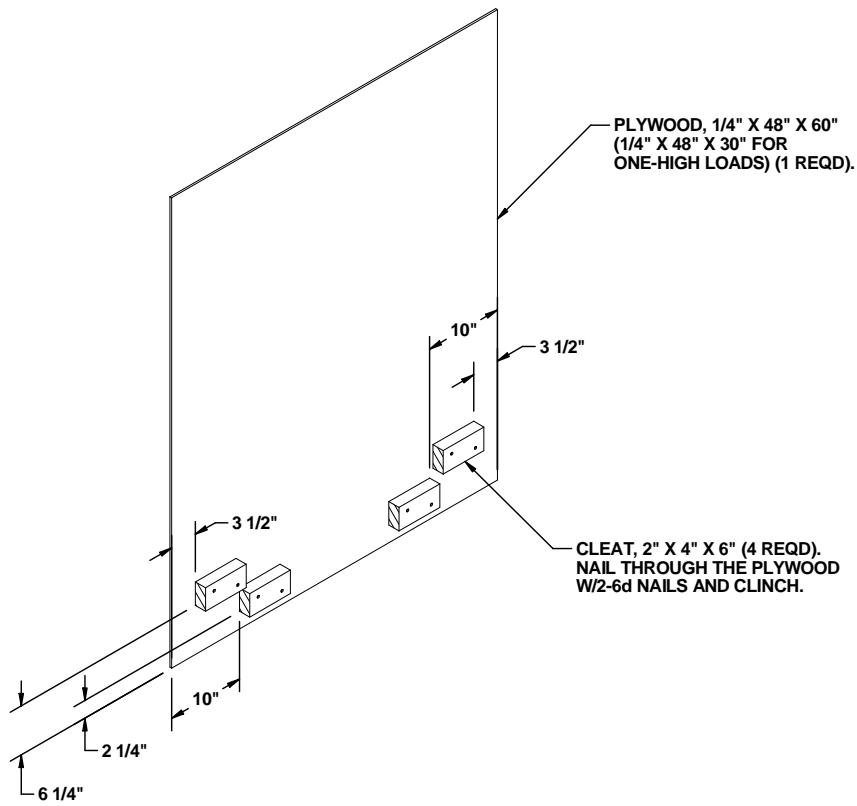

SIDE BLOCKING ASSEMBLY