

LOADING AND BRACING (TL & LTL) ON FLATBED TRAILERS[⊕] OF HAVNAP (AGM-142) MISSILES PACKED IN CNU-496 CONTAINERS

INDEX

ITEM	PAGE(S)
GENERAL NOTES AND MATERIAL SPECIFICATIONS	2
CONTAINER DETAIL	3
EIGHT UNIT LOAD ON A 48' -0" LONG BY 8' -0" WIDE FLATBED TRAILER (WEB STRAP TIEDOWN METHOD)	4-5
SIX UNIT LOAD ON A 48' -0" LONG BY 8' -0" WIDE FLATBED TRAILER (CHAIN TIEDOWN METHOD)	6-7
FIVE UNIT LOAD ON A 48' -0" LONG BY 8' -0" WIDE FLATBED TRAILER (STEEL STRAPPING METHOD)	8-9
TYPICAL LTL (ONE UNIT LOAD)	10
DETAILS	11
PROVISIONS FOR THE USE OF FIRE HOSE IN LIEU OF CHAIN BOARDS OR STRAPPING BOARDS	12

DISTRIBUTION STATEMENT A:

APPROVED FOR PUBLIC RELEASE
DISTRIBUTION IS UNLIMITED.

**⊕ CAUTION: THE PROCEDURES SHOWN HEREIN ARE ONLY APPLICABLE TO
HIGHWAY MOVEMENTS, NOT TRAILER-ON-FLATCAR (TOFC) MOVEMENTS.**

U.S. ARMY MATERIEL COMMAND DRAWING

<p>APPROVED, U.S. ARMY JOINT MUNITIONS COMMAND</p> <p>RUS.ALLEN.J .1230354282</p> <small>Digitally signed by RUS.ALLEN.J.1230354282 DN: cn=US, ou=U.S. Government, ou=DoD, ou=PKI, ou=USA, cn=RUS.ALLEN.J.1230354282 Date: 2013.05.07 10:16:35 -05'00'</small>		<p>CAUTION: VERIFY PRIOR TO USE AT HTTPS://MHP.REDSTONE.ARMY.MIL THAT THIS IS THE MOST CURRENT VERSION OF THIS DOCUMENT. THIS IS PAGE 1 OF 12.</p>			
<p>DO NOT SCALE</p>		<p>DECEMBER 2013</p>			
DESIGN ENGINEER	BASIC REV.	CANH TRAN			
ENGINEERING DIVISON	FIEFFER.LAURA .A.1230375727	<small>Digitally signed by FIEFFER.LAURA.A.1230375727 DN: cn=US, ou=U.S. Government, ou=DoD, ou=PKI, ou=USA, cn=FIEFFER.LAURA.A.1230375727 Date: 2012.11.28 16:13:47 -08'00'</small>			
TEST ENGINEER		TESTED	CLASS	DIVISION	DRAWING
EXPLOSIVE SAFETY DIRECTORATE	WILLIAMS.KENY ON.L.1231212392		19	48	8782
<p>APPROVED BY ORDER OF COMMANDING GENERAL, U.S. ARMY MATERIEL COMMAND</p> <p>SHIMP.UPTON .R.1231257183</p> <small>Digitally signed by SHIMP.UPTON.R.1231257183 DN: cn=US, ou=U.S. Government, ou=DoD, ou=PKI, ou=USA, cn=SHIMP.UPTON.R.1231257183 Date: 2013.05.08 08:57:28 -05'00'</small>			FILE	<p>SP11J40</p>	
<p>U.S. ARMY DEFENSE AMMUNITION CENTER</p>					

GENERAL NOTES

- A. THIS DOCUMENT HAS BEEN PREPARED AND ISSUED IN ACCORDANCE WITH AR 740-1 AND AUGMENTS TM 743-200-1 (CHAPTER 5).
- B. THE SPECIFIED OUTLOADING PROCEDURES ARE APPLICABLE TO LOADS OF HAVNAP (AGM-142) MISSILES PACKED IN CNU-496/E CONTAINERS. SUBSEQUENT REFERENCE TO CONTAINER HEREIN MEANS THE CONTAINER WITH MISSILE ITEMS. SEE PAGE 3 AND U.S. AIR FORCE DRAWING 9018070 FOR DETAILS OF THE CONTAINER.
- C. THE LOADS AS SHOWN HEREIN ARE BASED ON 48'-0" LONG BY 8'-0" WIDE FLATBED TRAILERS. TRAILERS OF OTHER LENGTH AND WIDTHS MAY BE USED. TRAILERS MUST HAVE WOOD OR WOOD AND METAL FLOORS. TRAILERS HAVING ALL-METAL FLOORS CANNOT BE USED. **CAUTION:** IF THE TRAILER FLOOR IS EQUIPPED WITH EXPOSED METAL DECKING ABOVE THE BOGIE ASSEMBLY, OR ELSEWHERE, FIELD MEASUREMENTS SHOULD BE MADE TO ENSURE THAT THE METAL DECKING DOES NOT INTERFERE WITH THE PROPER POSITIONING AND NAILING OF THE DUNNAGE AS SPECIFIED BY THE PROCEDURES SHOWN HEREIN.
- D. SELECTION OF A VEHICLE FOR THE TRANSPORT OF THE DESIGNATED ITEM IS THE RESPONSIBILITY OF THE ORIGINATING CARRIER AND THE SHIPPER. ONLY VEHICLES IN ACCORDANCE WITH THE REQUIREMENTS OF THE APPLICABLE REGULATORY DOCUMENTS WILL BE SELECTED FOR USE.
- E. GROSS WEIGHT AND AXLE DISTRIBUTION OF WEIGHT FOR A LOAD WILL BE THE RESPONSIBILITY OF THE CARRIER. THE CARRIER WILL ADVISE THE SHIPPER OF APPLICABLE LOADING REQUIREMENTS, AND THE SHIPPER WILL LOAD ACCORDINGLY.
- F. **NOTICE:** A SHIPMENT WILL BE POSITIONED ON A TRAILER CONSISTENT WITH STATE WEIGHT LAWS.
- G. SELECTION OF A VEHICLE USED TO TRANSPORT THE DESIGNATED ITEM MUST COMPLY WITH AR 55-355, CHAPTER 29, FOR EXPLOSIVES AND OTHER DANGEROUS ARTICLES, IN FULL.
- H. THESE PROCEDURES CAN ALSO BE UTILIZED FOR THE SHIPMENT OF THE CONTAINERS WHEN THEY ARE LOADED WITH AN ITEM WHICH IS IDENTIFIED DIFFERENTLY BY NOMENCLATURE THAN THE ITEM DESIGNATED WITHIN THE DRAWING TITLE, OR WHEN THEY ARE EMPTY.
- J. OTHER TYPES OF LADING ITEMS MAY BE LOADED ON A TRAILER WHICH IS PARTIALLY LOADED WITH THE DESIGNATED ITEM, PROVIDING THE TOTAL LOAD IS COMPATIBLE, EXISTING DIRECTIVES ARE NOT VIOLATED, AND THE OTHER LADING ITEMS ARE BLOCKED AND BRACED TO EQUAL THE BLOCKING AND BRACING CRITERIA SPECIFIED HEREIN.
- K. **CAUTION:** REGARDLESS OF THE TYPE OF TRAILER INVOLVED, ONLY THOSE TRAILERS HAVING TIEDOWN ANCHORING FACILITIES WHICH PROVIDE HOLDING STRENGTH EQUAL TO OR GREATER THAN THE STRENGTH OF THE HOLD-DOWN STRAPS OR CHAINS AND WHICH ALIGN NEAR THE INDICATED LOCATIONS FOR THE HOLD-DOWN STRAPS OR CHAINS SHOULD BE USED. IF THE TRAILER ANCHOR DEVICES ARE NOT PROPERLY POSITIONED TO RECEIVE STRAPPING OR CHAINS, AS SHOWN, OR IF THE ANCHOR DEVICES ARE NOT EQUAL TO OR GREATER THAN THE STRENGTH OF THE TIEDOWN STRAPS OR CHAINS, STEEL STRAPS MAY BE APPLIED TO FORM A COMPLETE LOOP WHICH ENCOMPASSES BOTH THE LADING AND THE TRAILER FRAME AND/OR BED. **CAUTION:** AVOID TRAILER WHEELS, FIFTH WHEEL PLATE CONTROLS AND OTHER APPURTENANCES. USE EDGE PROTECTORS OR PADS ON ALL SHARP EDGES. NEITHER CHAINS NOR WEB STRAPS WILL BE APPLIED TO FORM A COMPLETE LOOP THAT ENCOMPASSES THE LADING AND THE TRAILER FRAME AND/OR BED.

(CONTINUED AT RIGHT)

MATERIAL SPECIFICATIONS

- LUMBER** - - - - - : SEE TM 743-200-1 (DUNNAGE LUMBER) AND VOLUNTARY PRODUCT STANDARD PS 20.
- NAILS** - - - - - : ASTM F1667; COMMON STEEL NAIL (NLCMS OR NLCMS).
- STRAP, WEB, COMMERCIAL** - - - - - : WEB SLING AND TIEDOWN ASSOCIATION RECOMMENDED STANDARD SPECIFICATION FOR SYNTHETIC WEB TIEDOWNS, WSTDA-T-1, REVISED 2005.
- STRAPPING, STEEL** - - - - - : ASTM D3953; FLAT STRAPPING, TYPE 1, HEAVY DUTY, FINISH A, B (GRADE 2), OR C.
- SEAL, STRAP** - - - - - : ASTM D3953; CLASS H, FINISH A, B (GRADE 2), OR C, DOUBLE NOTCH TYPE, STYLE I, II, OR IV.
- STAKE POCKET PROTECTOR** - - - - - : COMMERCIAL GRADE.
- ANTI-CHAFING MATERIAL** - - - - - : MIL-PRF-121 (OR EQUAL); NEUTRAL BARRIER MATERIAL.
- CHAIN** - - - - - : NATIONAL ASSOCIATION OF CHAIN MANUFACTURER'S WELDED CHAIN SPECIFICATION ADOPTED NOVEMBER 1999.
- LOAD BINDER** - - - - - : FED SPEC GG-B-325.
- WIRE, CARBON STEEL** - - - - - : ASTM A853; ANNEALED AT FINISH, BLACK OXIDE FINISH, 0.0800" DIA, GRADE 1006 OR BETTER.

(GENERAL NOTES CONTINUED)

- L. IF THE CAPACITY OF THE MATERIAL HANDLING EQUIPMENT PERMITS, IT IS RECOMMENDED THAT CONTAINERS BE UNITIZED PRIOR TO PLACEMENT ABOARD THE TRAILER. SEE THE "UNITIZING AND HANDLING GUIDANCE" ON PAGE 3.
- M. A STAGGERED NAILING PATTERN WILL BE USED WHEREVER POSSIBLE WHEN NAILS ARE DRIVEN INTO JOINTS OF DUNNAGE ASSEMBLIES. ALSO, A STAGGERED NAILING PATTERN WILL BE USED WHEN DUNNAGE IS NAILED TO THE FLOOR OF THE TRANSPORTING VEHICLE, OR WHEN LAMINATING DUNNAGE. THE NAILING PATTERN WILL BE ADJUSTED AS REQUIRED SO THAT A NAIL DOES NOT PENETRATE INTO OR NEAR A CRACK BETWEEN FLOOR BOARDS. ADDITIONALLY, THE NAILING PATTERN FOR AN UPPER PIECE OF LAMINATED DUNNAGE WILL BE ADJUSTED AS REQUIRED SO THAT A NAIL FOR THAT PIECE WILL NOT BE DRIVEN THROUGH THE PIECE ONTO OR RIGHT BESIDE A NAIL IN A LOWER PIECE.
- N. WHEN STEEL STRAPPING IS SEALED AT AN END-OVER-END LAP JOINT, A MINIMUM OF ONE SEAL WITH TWO PAIR OF NOTCHES WILL BE USED TO SEAL THE JOINT WHEN A NOTCH-TYPE SEALER IS BEING USED. A MINIMUM OF TWO SEALS, BUTTED TOGETHER WITH TWO PAIR OF CRIMPS PER SEAL WILL BE USED TO SEAL THE JOINT WHEN A CRIMP-TYPE SEALER IS BEING USED. REFER TO THE STRAP JOINT DETAILS ON PAGE 12 FOR GUIDANCE.
- O. THE TRANSPORTING VEHICLE OPERATOR SHOULD BE INSTRUCTED TO PERIODICALLY INSPECT THE TIEDOWN CHAINS AND LOAD BINDERS DURING TRANSIT AND TIGHTEN IF NECESSARY.
- P. THE NUMBER OF LADING UNITS MAY BE ADJUSTED TO FIT THE SIZE OF THE TRAILER TO BE LOADED OR THE QUANTITY TO BE SHIPPED. THE APPROVED METHODS SHOWN HEREIN MUST BE FOLLOWED AS CLOSELY AS POSSIBLE FOR BLOCKING, BRACING AND STAYING OF THE DESIGNATED ITEM.
- Q. PLACE ANTI-CHAFING NEUTRAL BARRIER MATERIAL UNDER THE STEEL STRAPPING AND CHAINS AT ALL POINTS OF CONTACT WITH THE CONTAINER, EXCEPT THROUGH FORKLIFT OPENINGS, AND SECURE TO PREVENT DISLODGEMENT DURING AND AFTER STRAP OR CHAIN APPLICATION. STRIPS OF ANTI-CHAFING MATERIAL MAY BE TAPED OR STRING-TIED TO THE CONTAINER, OR IT CAN BE FORMED INTO STRAP OR CHAIN ENCIRCLING TUBES BY WINDING MATERIAL AROUND THE STRAP OR CHAIN TO FORM A SELF-HOLDING UNIT.
- R. DUNNAGE LUMBER SPECIFIED IS OF NOMINAL SIZE. FOR EXAMPLE, 1" X 4" MATERIAL IS ACTUALLY 3/4" THICK BY 3-1/2" WIDE AND 2" X 6" MATERIAL IS ACTUALLY 1-1/2" THICK BY 5-1/2" WIDE.
- S. CONVERSION TO METRIC EQUIVALENTS: DIMENSIONS WITHIN THIS DOCUMENT ARE EXPRESSED IN INCHES, AND WEIGHTS ARE EXPRESSED IN POUNDS. WHEN NECESSARY, THE METRIC EQUIVALENTS MAY BE COMPUTED ON THE BASIS OF ONE INCH EQUALS 25.4MM, AND ONE POUND EQUALS 0.454 KG.

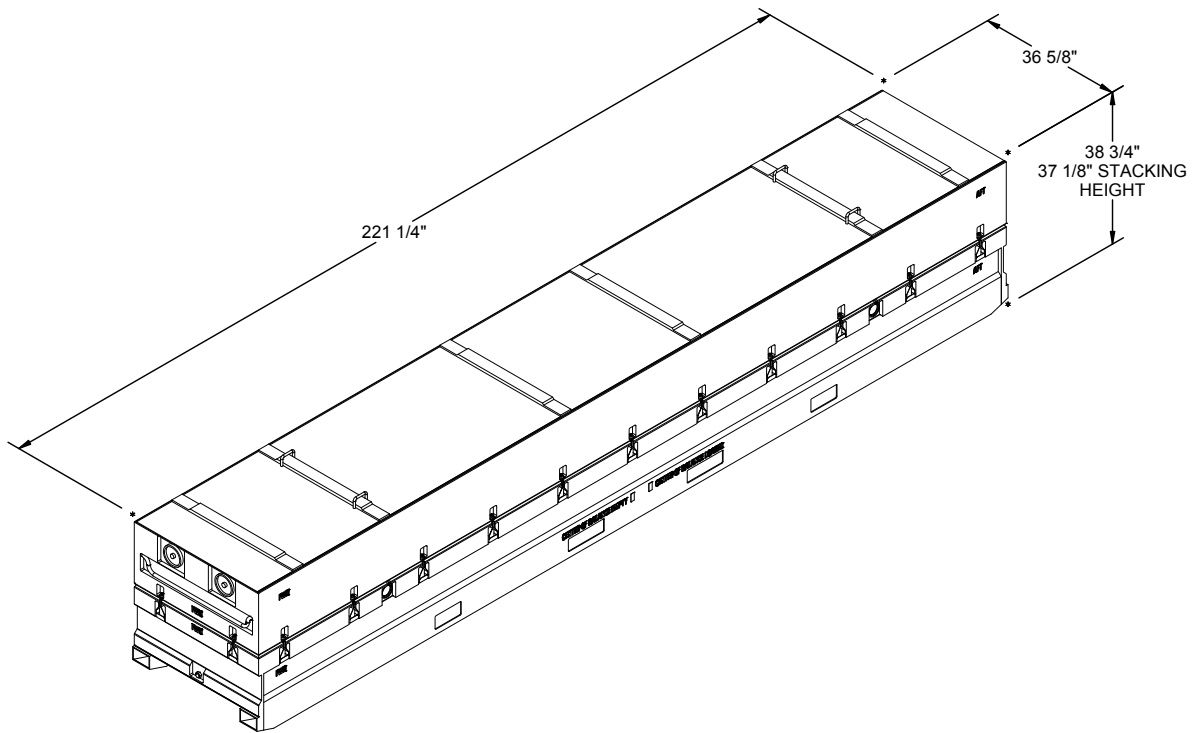

CNU-496 CONTAINER

GROSS WEIGHT - - - - - 4,400 LBS
 CUBE - - - - - 182.0 CU FT

UNITIZATION AND HANDLING GUIDANCE

1. STACKING CONTAINERS FOR LOADING:
 - A. AN UPPER CONTAINER SHOULD BE PLACED AS CLOSE AS POSSIBLE IN VERTICAL ALIGNMENT WITH THE NEXT LOWER CONTAINER.
 - B. POSITION THE AFT END OF AN UPPER CONTAINER ABOVE THE AFT END OF THE NEXT LOWER CONTAINER.
 - C. THE CONTAINER SKIDS OF AN UPPER CONTAINER SHOULD BE FULLY SEATED AGAINST THE SKID LOCATOR PIECES ON THE COVER OF THE NEXT LOWER CONTAINER.
2. INSTALLATION OF UNITIZING STRAPS:
 - A. STRAPS WILL BE POSITIONED SO AS TO ENIRCLE THE CONTAINERS AND SO THAT THE STRAPPING LAYS FLAT AND STRAIGHT WITH THE BODY SURFACE OF THE CONTAINER; I.E., VERTICAL ALONG THE SIDES AND FLAT ACROSS THE TOP AND BOTTOM OF THE STACK.
 - B. PLACE ANTI-CHAFING NEUTRAL BARRIER MATERIAL UNDER THE STRAPPING AT ALL POINTS OF CONTACT WITH THE CONTAINER AND SECURE TO PREVENT DISLODGE MENT DURING AND AFTER STRAP APPLICATION. STRIPS OF ANTI-CHAFING MATERIAL MAY BE TAPED OR STRING-TIED TO THE CONTAINER OR STRAPPING, OR IT CAN BE FORMED INTO STRAP EN CIRCLING TUBES BY WINDING THE MATERIAL AROUND THE STRAPPING TO FORM A SELF-HOLDING UNIT.
 - C. STRAPPING WILL BE FIRMLY TENSIONED AND EACH END-OVER-END LAP JOINT WILL BE SEALED WITH ONE DOUBLE NOTCHED OR TWO DOUBLE CRIMPED STRAP SEALS. SEE GENERAL NOTE "N" ON PAGE 2. THE LAP JOINTS WILL BE MADE ALONG THE SIDE OF THE STACK AS SHOWN. DURING STRAP TENSIONING, CARE SHOULD BE EXERCISED TO ENSURE THAT THE CONTAINERS ARE NOT DAMAGED. EXCESS STRAPPING (STRAP ENDS) SHOULD BE CUT OFF OR BROKEN OFF NEAR THE JOINT SEALS.

(CONTINUED AT RIGHT)

(UNITIZATION AND HANDLING GUIDANCE CONTINUED)

3. CONTAINER OR CONTAINER STACK HANDLING:
 - A. ONLY APPROVED AND APPROPRIATELY SIZED MATERIAL HANDLING EQUIPMENT WILL BE USED FOR HANDLING THE DEPICTED CONTAINERS. APPROVED MATERIAL HANDLING EQUIPMENT (FORKLIFT TRUCKS, CRANES, HAND TRUCKS, DOLLIES, ROLLER ASSEMBLIES, SLINGS, SPREADER BARS, ETC.) IS SPECIFIED ELSEWHERE.
 - B. PRECAUTIONARY HANDLING TECHNIQUES NORMALLY EMPLOYED OR AS SPECIFIED FOR THE TYPE OF COMMODITY INVOLVED WILL BE OBSERVED.
 - C. IF HANDLING IS ACCOMPLISHED WITH A FORKLIFT TRUCK, THE CONTAINERS SHOULD BE HANDLED FROM A SIDE POSITION AS MUCH AS POSSIBLE. CARE MUST BE EXERCISED WHEN INSERTING FORKS UNDER A CONTAINER, TO PREVENT DAMAGE TO THE CONTAINER BY THE FORK TINES OR THE FORKLIFT PACKAGE GUARD. IF ONE CONTAINER IS HANDLED BY SLINGING, THE SLING MAY BE ATTACHED TO THE LIFTING POINTS ON THE CONTAINER. DO NOT HANDLE STACKED CONTAINERS WITH A SLING.

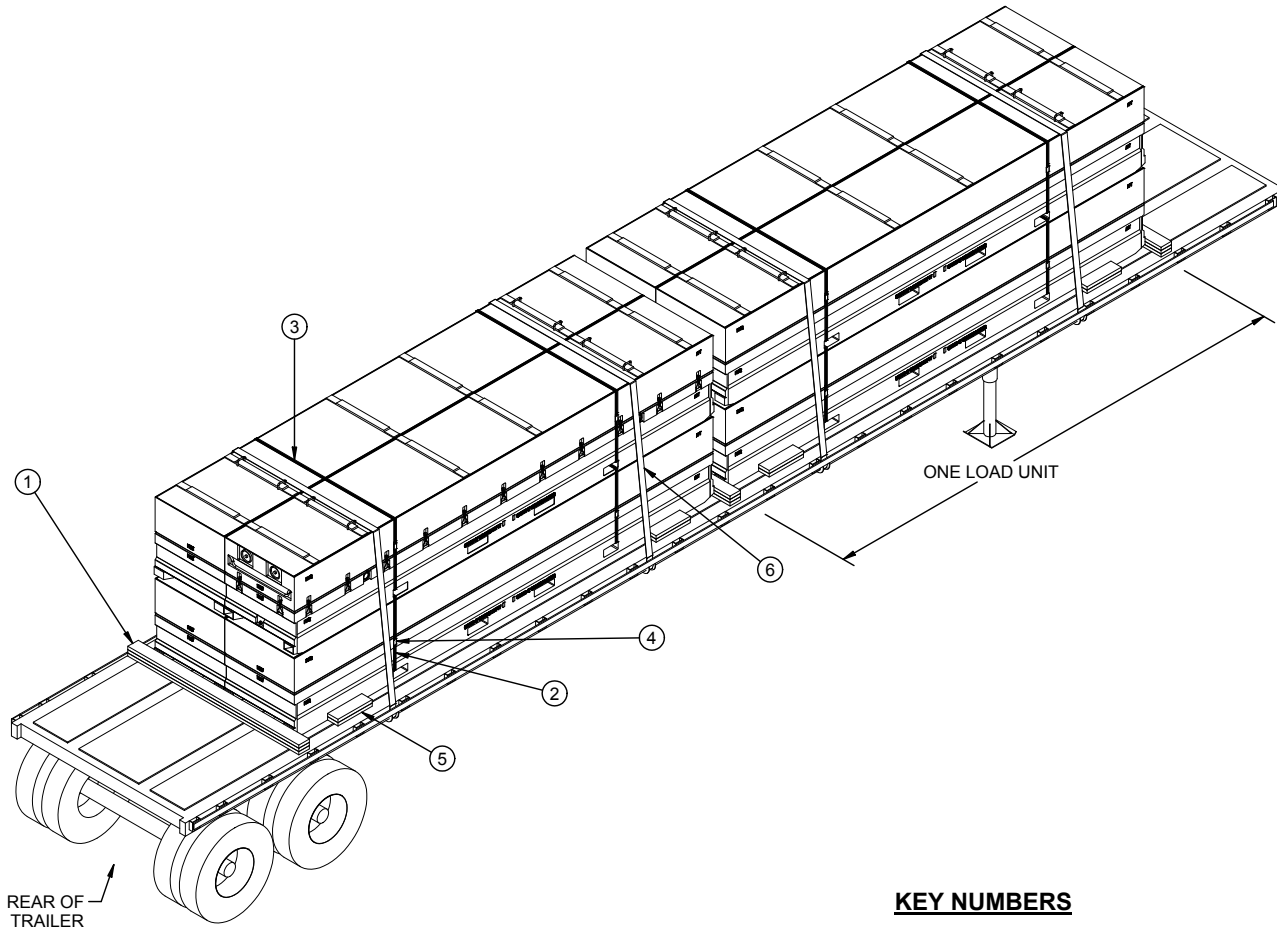

ISOMETRIC VIEW

KEY NUMBERS

- ① HEADER, 2" X 6" X 7'-6" (TRIPLED) (3 REQD). PRE-POSITION THE CENTER HEADER AS SHOWN BY THE "PRE-POSITIONED DUNNAGE PLAN VIEW A" ON PAGE 5. NAIL THE FIRST PIECE TO THE TRAILER FLOOR W/6-10d NAILS. LAMINATE THE SECOND PIECE TO THE FIRST W/6-20d NAILS. LAMINATE THE THIRD PIECE TO THE SECOND W/6-20d NAILS.
- ② STACK UNITIZING STRAP, 1-1/4" X .035" OR .031" X 12'-9" LONG STEEL STRAPPING (8 REQD, 2 PER STACK). INSTALL THROUGH FORKLIFT OPENINGS SO AS TO ENCIRCLE THE VERTICALLY ADJACENT CONTAINERS IN ONE STACK AS SHOWN. POSITION AS FAR APART AS ALLOWABLE. SEE SPECIAL NOTE 2 ON PAGE 5.
- ③ BUNDLING STRAP, 1-1/4" X .035" OR .031" X 18'-7" LONG STEEL STRAPPING (4 REQD, 2 PER LOAD UNIT). INSTALL THROUGH FORKLIFT OPENINGS SO AS TO ENCIRCLE THE LATERALLY ADJACENT CONTAINERS IN THE TOP LAYER AS SHOWN. POSITION AS FAR APART AS ALLOWABLE. SEE SPECIAL NOTE 2 ON PAGE 5.
- ④ SEAL FOR 1-1/4" STEEL STRAPPING (12 REQD, 1 PER STRAP). DOUBLE NOTCH EACH SEAL.
- ⑤ SIDE BLOCKING, 2" X 6" X 18" (DOUBLED) (8 REQD). POSITION AGAINST CONTAINER SKID AS SHOWN. NAIL THE FIRST PIECE TO THE TRAILER FLOOR W/5-10d NAILS. LAMINATE THE SECOND PIECE TO THE FIRST IN A SIMILAR MANNER.
- ⑥ WEB STRAP ASSEMBLY (4 REQD). POSITION TO EXTEND FROM A WINCH ON ONE SIDE OF THE TRAILER, OVER THE CONTAINERS, TO AN ATTACHMENT POINT ON THE OPPOSITE SIDE. SEE THE "SPECIAL PROVISIONS FOR WEB STRAP TIEDOWN" ON PAGE 5.

BILL OF MATERIAL

LUMBER	LINEAR FEET	BOARD FEET
2" X 6"	92	92
NAILS	NO. REQD	POUNDS
10d (3")	98	1-1/2
20d (4")	36	1-1/2
STEEL STRAPPING, 1-1/4" - 176' REQD - - - 26 LBS		
SEAL FOR 1-1/4" STRAPPING 12 REQD - - 1/2 LBS		
WEB STRAP ASSEMBLY - - - - - 4 REQD		

LOAD AS SHOWN

ITEM	QUANTITY	WEIGHT (APPROX)
CNU-496 CONTAINER	8	35,200 LBS
DUNNAGE		233 LBS
TOTAL WEIGHT		35,433 LBS (APPROX)

SPECIAL NOTES:

1. AN EIGHT UNIT LOAD IS SHOWN ON A 48'-0" LONG BY 8'-0" WIDE FLATBED TRAILER. LONGER OR WIDER TRAILERS MAY BE USED.
2. IF THE CAPACITY OF MATERIAL HANDLING EQUIPMENT (MHE) IS ADEQUATE, TWO CONTAINERS MAY BE UNITIZED PRIOR TO LOADING ON THE FLATBED TRAILER. IF THIS IS NOT POSSIBLE, THEN THE STACK UNITIZING STRAPS MUST BE POSITIONED AS THE LOADING PROGRESSES.
3. IF CHAINS AND LOAD BINDERS ARE TO BE USED FOR LOAD SECUREMENT IN LIEU OF THE WEB STRAPPING, REFER TO THE PROCEDURES ON PAGES 6 AND 7 FOR GUIDANCE. IF STEEL STRAPS ARE TO BE USED FOR LOAD SECUREMENT, REFER TO THE PROCEDURES ON PAGES 8 AND 9 FOR GUIDANCE.
4. THE DEPICTED LOAD CAN BE REDUCED TO SUIT THE QUANTITY TO BE SHIPPED. A LOAD MAY BE REDUCED IN MULTIPLES OF TWO CONTAINERS OR ENTIRE LOAD UNITS OF FOUR CONTAINERS. SEE THE DETAILS ON PAGES 6, 8, AND 10 FOR OTHER LOADING CONFIGURATIONS AND QUANTITIES.

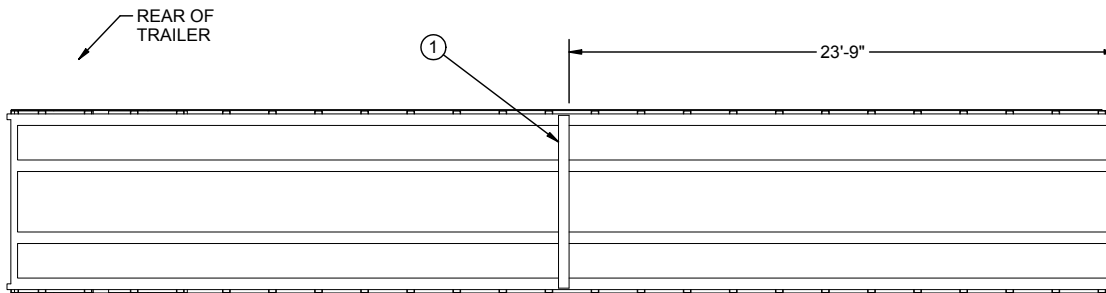

PRE-POSITIONED DUNNAGE PLAN VIEW A

KEY NUMBER REFER TO KEY NUMBERS ON PAGE 4

SPECIAL PROVISIONS FOR WEB STRAP TIEDOWN

LADING MAY BE SECURED TO A FLATBED TRAILER BY WEB STRAP ASSEMBLIES IN LIEU OF STEEL STRAPPING OR CHAINS AND LOAD BINDERS, PROVIDED THE FOLLOWING CONDITIONS ARE MET.

1. ONLY WEB STRAPS OF GOOD QUALITY WILL BE USED. ALL WEB STRAPS AND ASSOCIATED HARDWARE SHALL CONFORM TO THE WEB SLING & TIEDOWN ASSOCIATION RECOMMENDED STANDARD SPECIFICATION FOR SYNTHETIC WEB TIEDOWNS, WSTDA-T-1, REVISED 2005.
2. ALL WEB STRAP TIEDOWN ASSEMBLIES SHALL BE PERMANENTLY LABELED WITHIN 18" OF ONE END TO SHOW:
 - A. NAME OR TRADEMARK OF MANUFACTURER
 - B. WORKING LOAD LIMIT (WLL)
3. WEB STRAP ASSEMBLY MINIMUM BREAKING STRENGTH WILL BE AT LEAST THREE TIMES THE WLL MARKED ON THE STRAP.
4. THE TOTAL MINIMUM BREAKING STRENGTH (MBS) OF THE STRAPS USED TO RESTRAIN AMMUNITION ITEMS WILL BE AT LEAST 1-1/2 TIMES THE TOTAL WEIGHT OF THE ITEMS, WITH A MINIMUM OF TWO STRAPS POSITIONED OVER EACH LOAD UNIT ON A TRAILER. THE CARRIER SHALL PROVIDE WRITTEN PROOF OF THE MBS OF THE STRAPS TO THE SHIPPING ACTIVITY IF REQUESTED.
5. CARRIERS MUST COMPLY WITH ALL FEDERAL, STATE, AND LOCAL REGULATIONS APPLICABLE TO CARGO RESTRAINT USING WEB STRAPS.
6. WHEN USING STRAPS AND WINCHES FOR CARGO RESTRAINT, THE STRAPS WILL BE TENSIONED UNTIL TIGHT WITHOUT CAUSING DAMAGE TO THE CARGO. ONLY WINCH BARS WILL BE USED FOR OPERATING THE STRAP WINCHES.
7. BEFORE AND DURING INSTALLATION, THE WEB STRAP ASSEMBLIES SHALL BE INSPECTED FOR DEFECTS. STRAPS HAVING ANY OF THE FOLLOWING DEFECTS WILL NOT BE USED FOR THE RESTRAINT OF ANY AMMUNITION LOAD, WITH THE EXCEPTION OF ONE WITH FRAYED ENDS. A STRAP HAVING FRAYED ENDS CAN BE USED IF THE FRAYED END IS TRIMMED AND MELTED WITH HEAT OR FLAME UNTIL ALL STRANDS ARE SEIZED.

(CONTINUED AT RIGHT)

(SPECIAL PROVISIONS FOR WEB STRAP TIEDOWN CONTINUED)

- A. STRAP ASSEMBLY HARDWARE: SHALL BE INSPECTED FOR BENT HOOKS, GOUGES, CORROSION, SIGNS OF REPAIR, BENT RATCHETS OR WINCHES, WEAR, OR ANY OTHER NOTICEABLE DEFECTS.
 - B. STRAP WEBBING: SHALL BE INSPECTED FOR KNOTS, EXCESSIVE ABRASIVE WEAR, TEARS, PUNCTURES, CUTS, ACID OR CAUSTIC BURNS, BROKEN STITCHES, FRAYED ENDS, OIL OR GREASE SPOTS EXCEEDING 6 SQUARE INCHES, BLEACHING OF COLOR, INCREASED STIFFNESS, SPLICES, VISIBLE WEAR INDICATOR THREADS, OR ANY OTHER NOTICEABLE DEFECTS.
8. RATCHET HANDLES MUST BE IN THE LOCKED POSITION AND/OR WINCH LOCKING DEVICES MUST BE FULLY SEATED IN THE TEETH OF THE WINCH.
 9. IF THE WINCHES BEING USED ARE THE REMOVABLE TYPE HAVING BOLTS FOR ATTACHMENT TO THE TRAILER, CARE MUST BE EXERCISED WHEN ATTACHING THE WINCHES TO THE TRAILER. IF EXCESSIVE FORCE IS EXERTED ON THE BOLT DURING TENSIONING, DEFORMATION OF THE WINCH BRACKET MAY OCCUR, AND SUBSEQUENTLY CAUSE FAILURE OF THE WINCH BRACKET DURING TRANSPORT. WINCHES MUST BE FASTENED TO THE TRAILER WITH A MINIMUM OF TWO BOLTS.
 10. DRIVERS MUST BE INSTRUCTED TO PERIODICALLY CHECK THE TIGHTNESS OF THE WEB STRAP ASSEMBLIES AND RE-TIGHTEN, IF NECESSARY.
 11. IF PROVIDED ON OR WITH THE WEB STRAP ASSEMBLIES, SCUFF SLEEVES/WEB PROTECTORS WILL BE USED WHEREVER THE STRAP PASSES OVER A SHARP CORNER OR IRREGULAR SURFACE. IF NOT PROVIDED, ANTI-CHAFING MATERIAL OF A SUITABLE THICKNESS WILL BE USED TO ENSURE THAT THE STRAP WEBBING IS NOT DAMAGED DURING TRANSPORT OF THE LOAD.
 12. THE HARDWARE FITTING OF THE TIEDOWN ASSEMBLIES MUST BE ATTACHED TO THE TRAILER IN SUCH A MANNER THAT THEY WILL REMAIN IN PLACE IF SLACK DEVELOPS IN THE STRAP DURING TRANSPORT.

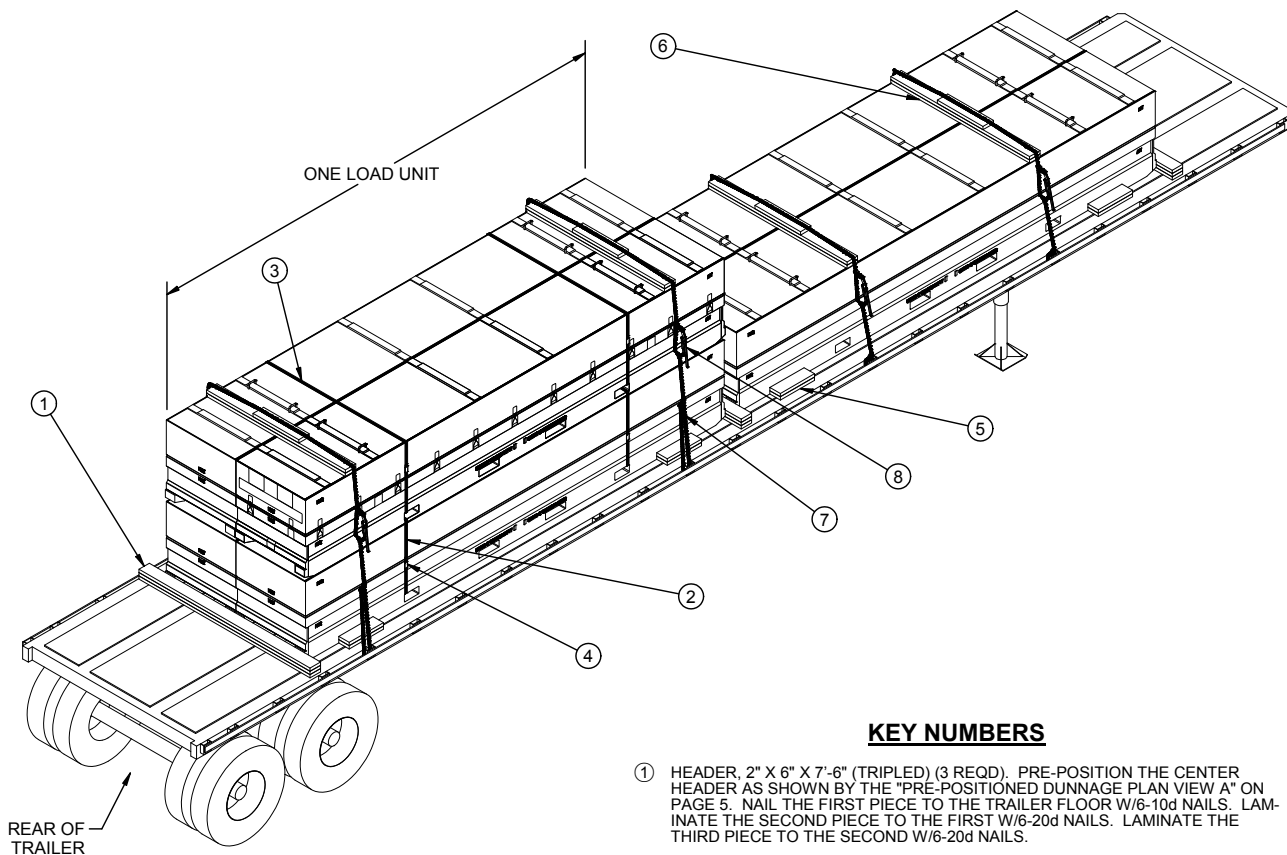

ISOMETRIC VIEW

KEY NUMBERS

- ① HEADER, 2" X 6" X 7'-6" (TRIPLED) (3 REQD). PRE-POSITION THE CENTER HEADER AS SHOWN BY THE "PRE-POSITIONED DUNNAGE PLAN VIEW A" ON PAGE 5. NAIL THE FIRST PIECE TO THE TRAILER FLOOR W/6-10d NAILS. LAMINATE THE SECOND PIECE TO THE FIRST W/6-20d NAILS. LAMINATE THE THIRD PIECE TO THE SECOND W/6-20d NAILS.
- ② STACK UNITIZING STRAP, 1-1/4" X .035" OR .031" X 12'-9" LONG STEEL STRAPPING (4 REQD, 2 PER STACK). INSTALL THROUGH FORKLIFT OPENINGS SO AS TO ENCIRCLE THE VERTICALLY ADJACENT CONTAINERS IN ONE STACK AS SHOWN. POSITION AS FAR APART AS ALLOWABLE. SEE SPECIAL NOTE 2 ON PAGE 7.
- ③ BUNDLING STRAP, 1-1/4" X .035" OR .031" X 18'-7" LONG STEEL STRAPPING (2 REQD, 2 PER LOAD UNIT). INSTALL THROUGH FORKLIFT OPENINGS SO AS TO ENCIRCLE THE LATERALLY ADJACENT CONTAINERS IN THE TOP LAYER AS SHOWN. POSITION AS FAR APART AS ALLOWABLE.
- ④ SEAL FOR 1-1/4" STEEL STRAPPING (6 REQD, 1 PER STRAP). DOUBLE NOTCH EACH SEAL.
- ⑤ SIDE BLOCKING, 2" X 6" X 18" (DOUBLED) (8 REQD). POSITION AGAINST CONTAINER SKID AS SHOWN. NAIL THE FIRST PIECE TO THE TRAILER FLOOR W/5-10d NAILS. LAMINATE THE SECOND PIECE TO THE FIRST IN A SIMILAR MANNER.
- ⑥ CHAIN BOARD ASSEMBLY (4 REQD). SEE SPECIAL NOTE 3 AND THE DETAIL ON PAGE 7.
- ⑦ CHAIN, BINDING, 5/16" OR 3/8", GRADE 70, BY A LENGTH TO SUIT (REF: 25'-2") (4 REQD). POSITION AS SHOWN, ATTACHED TO A STAKE POCKET. DO NOT ATTACH TO RUB RAIL. SEE THE "SPECIAL PROVISIONS FOR CHAIN TIEDOWN" ON PAGE 7.
- ⑧ LOAD BINDER, 5/16" OR 3/8", OVER-CENTER TYPE (4 REQD, 1 PER CHAIN). WIRE TIE HANDLE TO PREVENT OPENING DURING TRANSPORT. FASTEN THE TENSIONED CHAIN TO THE CHAIN BOARD W/1-20d NAIL AT EACH END, BY DRIVING EACH NAIL INTO THE CHAIN BOARD THRU AN OPENING IN A CHAIN LINK AND BENDING IT OVER THE LINK.

BILL OF MATERIAL

LUMBER	LINEAR FEET	BOARD FEET
2" X 6"	149	149
NAILS	NO. REQD	POUNDS
10d (3")	142	2-1/4
20d (4")	36	1-1/2
STEEL STRAPPING, 1-1/4" - 88'- REQD	- - -	13 LBS
SEAL FOR 1-1/4" STRAPPING - 6 REQD	- - -	1/2 LBS
CHAIN, BINDING, 5/16" - 83'- REQD	- - -	99 LBS
BINDER, LOAD - - - - -	4 REQD	24 LBS

LOAD AS SHOWN

ITEM	QUANTITY	WEIGHT (APPROX)
CNU-496 CONTAINER	- - 6 - - - - -	26,400 LBS
DUNNAGE	- - - - -	435 LBS
TOTAL WEIGHT		26,835 LBS (APPROX)

SPECIAL NOTES:

1. A SIX UNIT LOAD IS SHOWN ON A 48'-0" LONG BY 8'-0" WIDE FLATBED TRAILER. LONGER OR WIDER TRAILERS MAY BE USED.
2. IF THE CAPACITY OF MATERIAL HANDLING EQUIPMENT (MHE) IS ADEQUATE, TWO CONTAINERS MAY BE UNITIZED PRIOR TO LOADING ON THE FLATBED TRAILER. IF THIS IS NOT POSSIBLE, THEN THE STACK UNITIZING STRAPS MUST BE POSITIONED AS THE LOADING PROGRESSES.
3. **CAUTION:** THE CHAIN AND PURCHASE BOARDS, AND CHAIN ASSEMBLIES MUST BE IN VERTICAL ALIGNMENT WITH THE TRAILER STAKE POCKET PROVISIONS. SHIFT THE LOAD FORE OR AFT AS NECESSARY TO ACCOMMODATE VARIATIONS IN STAKE POCKET LOCATION.
4. IF WEB STRAPS ARE TO BE USED FOR LOAD SECUREMENT IN LIEU OF THE CHAINS AND LOAD BINDERS, REFER TO THE PROCEDURES ON PAGES 4 AND 5 FOR GUIDANCE. IF STEEL STRAPS ARE TO BE USED FOR LOAD SECUREMENT, REFER TO THE PROCEDURES ON PAGES 8 AND 9 FOR GUIDANCE.
5. THE DEPICTED LOAD CAN BE REDUCED OR INCREASED TO SUIT THE QUANTITY TO BE SHIPPED. A LOAD MAY BE REDUCED OR INCREASED IN MULTIPLES OF TWO CONTAINERS OR ENTIRE LOAD UNITS OF FOUR CONTAINERS. SEE THE DETAILS ON PAGES 4, 8, AND 10 FOR OTHER LOADING CONFIGURATIONS AND QUANTITIES.

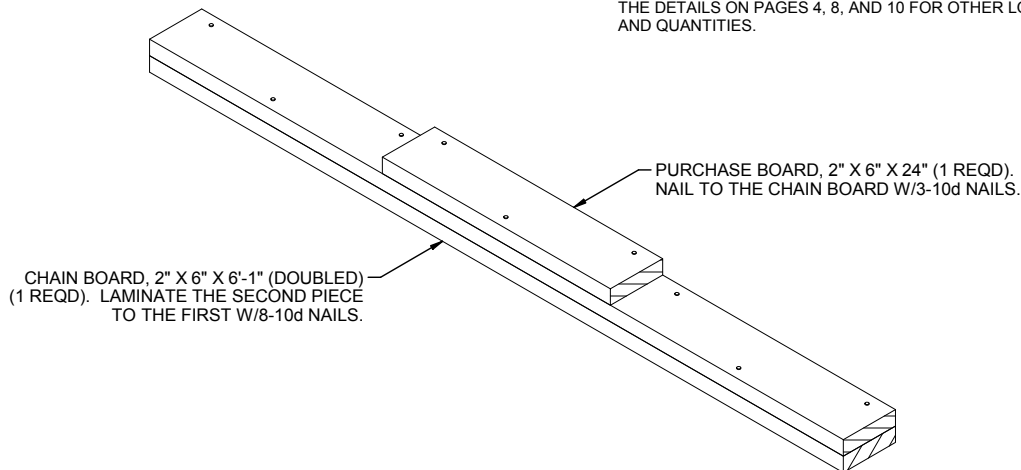

CHAIN BOARD ASSEMBLY

THE ASSEMBLY DEPICTED ABOVE IS FOR USE IN THE CHAIN TIEDOWN METHOD WHERE TWO CONTAINERS OR STACKS OF CONTAINERS ARE Laterally ADJACENT.

SPECIAL PROVISIONS FOR CHAIN TIEDOWN

LADING MAY BE SECURED TO THE FLATBED TRAILER BY CARRIER-OWNED CHAINS AND LOAD BINDERS IN LIEU OF SPECIFIED STRAPPING, PROVIDED THE FOLLOWING CONDITIONS ARE MET AND THE PROCEDURES CONTAINED ON PAGES 6 AND 7 ARE FOLLOWED.

1. ONLY CHAINS AND LOAD BINDERS OF GOOD QUALITY WILL BE USED. ALL CHAINS AND LOAD BINDERS SHALL CONFORM TO THE NATIONAL ASSOCIATION OF CHAIN MANUFACTURER'S WELDED CHAIN SPECIFICATION ADOPTED NOVEMBER 1999.
2. ALL CHAINS SHALL BE MARKED AS PRESCRIBED BY THE NATIONAL ASSOCIATION OF CHAIN MANUFACTURER'S WELDED CHAIN SPECIFICATION ADOPTED NOVEMBER 1999. AT LEAST ONE LINK IN EVERY 36 LINKS SHALL CARRY THE MANUFACTURER'S PERMANENT AND DISTINCTIVE MARK IDENTIFYING THE GRADE OF CHAIN. CHAINS NOT MARKED IN THIS MANNER SHALL NOT BE USED. IN ADDITION TO THE GRADE MARKING, THE CHAIN MAY ALSO CARRY LETTER MARKINGS OR SYMBOLS IDENTIFYING THE CHAIN MANUFACTURER. THE PRESENCE OF THE MANUFACTURER'S IDENTIFICATION MARKING IS NOT MANDATORY.
3. BEFORE AND DURING INSTALLATION, THE CHAINS AND LOAD BINDERS SHALL BE INSPECTED FOR BENT HOOKS, STRETCH, GOUGES, BENT LINKS, WEAR, OR ANY OTHER NOTICEABLE DEFECTS. ANY DEFICIENCY SHALL BE CAUSE FOR REJECTION OF A CHAIN OR LOAD BINDER. CHAINS MUST NOT BE TWISTED DURING INSTALLATION. **CAUTION:** EXTREME CARE MUST BE EXERCISED WHEN TENSIONING CHAINS TO PREVENT DAMAGE OR PERMANENT DEFORMATION TO THE LADING.
4. CHAIN SIZES AND GRADES APPROVED FOR USE WITH FLATBED TRAILER LOADS ARE AS FOLLOWS:
 - A. 3/8", GRADE 43 HIGH TEST CHAIN
 - B. 5/16", GRADE 70 TRANSPORT CHAIN
 - C. 3/8", GRADE 70 TRANSPORT CHAIN
 - D. 5/16", GRADE 80 ALLOY STEEL CHAIN
 - E. 3/8", GRADE 80 ALLOY STEEL CHAIN

(CONTINUED AT RIGHT)

(SPECIAL PROVISIONS FOR CHAIN TIEDOWN CONTINUED)

5. THE GRABHOOKS ON THE ENDS OF THE CHAIN MAY BE OF THE FOLLOWING TYPES WITH GRADE MARKINGS AS INDICATED.
 - A. CLEVIS GRABHOOKS, 3/8" SIZE, DO NOT REQUIRE GRADE MARKING. ALLOY GRABHOOKS, 5/16" SIZE, SHALL CARRY THE MANUFACTURER'S GRADE MARK OF 7, 70, OR 700. THE HOOKS SHALL BE USED ON THE APPROPRIATE SIZE CHAIN.
 - B. CLOSED EYE GRABHOOKS, 3/8" AND 5/16" SIZE, MAY BE USED ON THE APPROPRIATE SIZE CHAIN IF THEY ARE A PART OF A CHAIN ASSEMBLY WHICH WAS PROVIDED BY A CHAIN MANUFACTURER, AND THE CHAIN ASSEMBLY CARRIES THE CORRECT GRADE IDENTIFICATION MARKING AS PREVIOUSLY STATED. CLOSED EYE GRABHOOKS THAT FORM A PART OF THE CHAIN ASSEMBLY ARE EXEMPT FROM GRADE MARKINGS.
6. CONNECTING LINKS USED FOR CHAIN REPAIR MUST BE CORRECTLY MARKED AND BE EQUAL TO OR GREATER IN STRENGTH THAN THE CHAIN THEY ARE REPAIRING. CHAINS WITH UNMARKED CONNECTING LINKS SHALL NOT BE USED.
7. CHAIN AND FITTING OF A HIGHER GRADE MAY BE SUBSTITUTED FOR THE GRADES SPECIFIED IN NOTE 4 ABOVE.
8. LOAD BINDERS SHALL BE 5/16" TO 3/8" SIZE AND HAVE A MINIMUM BREAKING STRENGTH OF 16,200 POUNDS (WORKING LOAD LIMIT OF 5,400 POUNDS). OVERCENTER TYPE LOAD BINDERS SHALL BE SAFETY WIRED TO PREVENT ACCIDENTAL OPENING DURING TRANSPORT. LOAD BINDER SIZE SHALL BE COMPATIBLE WITH THE SIZE OF THE CHAIN BEING USED.

SIX UNIT LOAD ON A 48'-0" LONG BY 8'-0" WIDE FLATBED TRAILER (CHAIN TIEDOWN METHOD)

PAGE 7

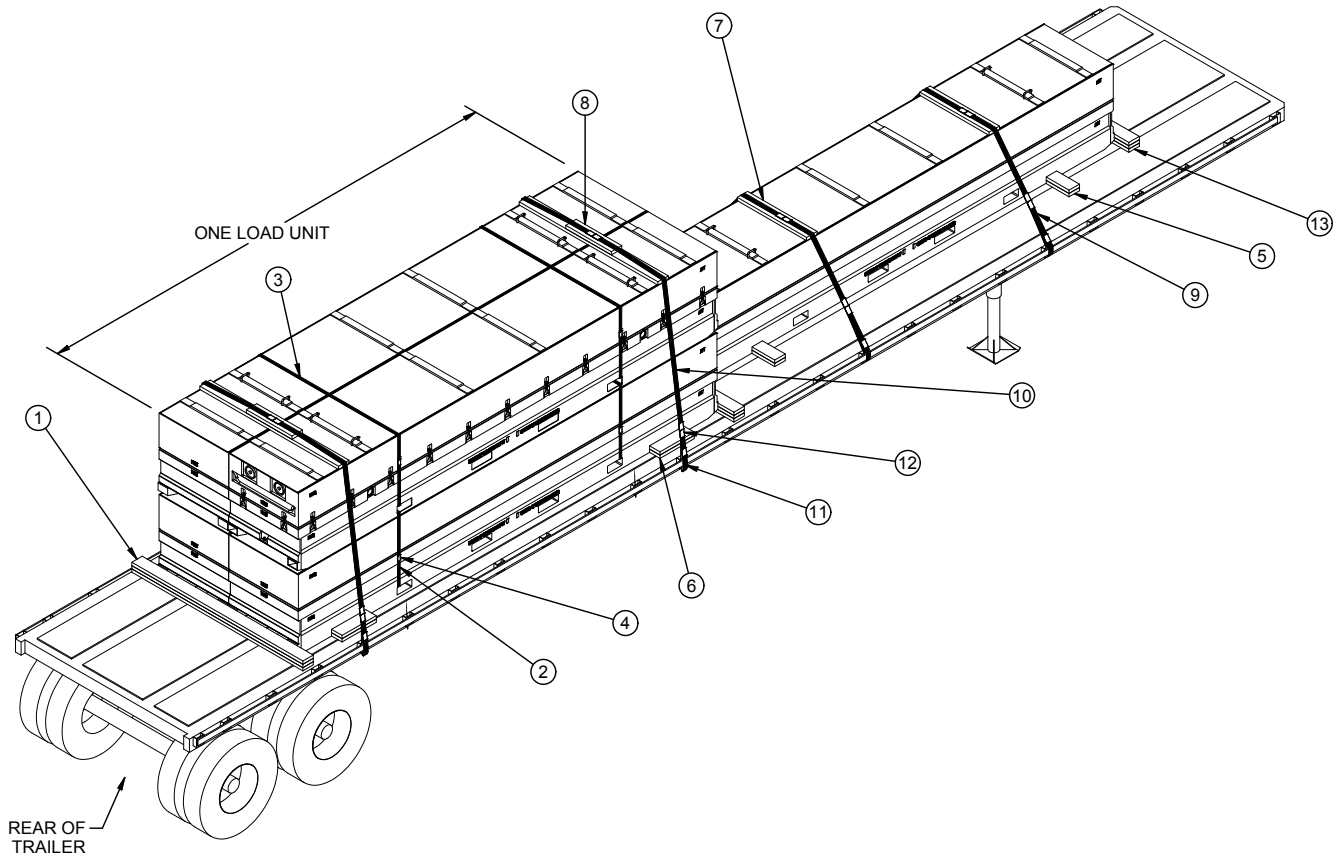

ISOMETRIC VIEW

(KEY NUMBERS CONTINUED)

- ⑩ HOLD-DOWN STRAP, 2" X .050" OR .044" X 23'-4" LONG STEEL STRAPPING (2 REQD). INSTALL EACH STRAP FROM TWO 11'-8" LONG PIECES. STAPLE TO THE PURCHASE BOARD W/2 STAPLES. DO NOT OVERTENSION THE HOLD-DOWN STRAP.
- ⑪ PAD, 2" X .050" OR .044" X 18" LONG STEEL STRAPPING (8 REQD). POSITION BETWEEN THE HOLD-DOWN STRAP AND THE TRAILER STAKE POCKET AND SEAL TO THE HOLD-DOWN STRAP. SEE "DETAIL A" ON PAGE 11. ALT: STAKE POCKET PROTECTOR (16 REQD). USE TWO UNDER EACH ANCHORING FACILITY WITH A HOLD-DOWN STRAP. SEE "DETAIL B" ON PAGE 11.
- ⑫ SEAL FOR 2" STEEL STRAPPING (32 REQD, 8 PER STRAP). DOUBLE CRIMP EACH SEAL, EXCEPT THOSE USED TO SECURE THE PADS. SEE THE DETAILS ON PAGE 11.
- ⑬ FORWARD HEADER, 2" X 6" X 52" (TRIPLED) (1 REQD). NAIL THE FIRST PIECE TO THE TRAILER FLOOR W/3-10d NAILS. LAMINATE THE SECOND PIECE TO THE FIRST W/3-20d NAILS. LAMINATE THE THIRD PIECE TO THE SECOND W/3-20d NAILS.

KEY NUMBERS

- ① HEADER, 2" X 6" X 7'-6" (TRIPLED) (2 REQD). PRE-POSITION THE CENTER HEADER AS SHOWN BY THE "PRE-POSITIONED DUNNAGE PLAN VIEW A" ON PAGE 5. NAIL THE FIRST PIECE TO THE TRAILER FLOOR W/6-10d NAILS. LAMINATE THE SECOND PIECE TO THE FIRST W/6-20d NAILS. LAMINATE THE THIRD PIECE TO THE SECOND W/6-20d NAILS.
- ② STACK UNITIZING STRAP, 1-1/4" X .035" OR .031" X 12'-9" LONG STEEL STRAPPING (4 REQD, 2 PER STACK). INSTALL THROUGH FORKLIFT OPENINGS SO AS TO ENCIRCLE THE VERTICALLY ADJACENT CONTAINERS IN ONE STACK AS SHOWN. POSITION AS FAR APART AS ALLOWABLE. SEE SPECIAL NOTE 2 ON PAGE 9.
- ③ BUNDLING STRAP, 1-1/4" X .035" OR .031" X 18'-7" LONG STEEL STRAPPING (2 REQD, 2 PER LOAD UNIT). INSTALL THROUGH FORKLIFT OPENINGS SO AS TO ENCIRCLE THE LATERALLY ADJACENT CONTAINERS IN THE TOP LAYER AS SHOWN. POSITION AS FAR APART AS ALLOWABLE.
- ④ SEAL FOR 1-1/4" STEEL STRAPPING (6 REQD, 1 PER STRAP). DOUBLE NOTCH EACH SEAL.
- ⑤ SIDE BLOCKING, 2" X 6" X 12" (DOUBLED) (4 REQD). POSITION AGAINST CONTAINER SKID AS SHOWN. NAIL THE FIRST PIECE TO THE TRAILER FLOOR W/4-10d NAILS. LAMINATE THE SECOND PIECE TO THE FIRST IN A SIMILAR MANNER.
- ⑥ SIDE BLOCKING, 2" X 6" X 18" (DOUBLED) (4 REQD). POSITION AGAINST CONTAINER SKID AS SHOWN. NAIL THE FIRST PIECE TO THE TRAILER FLOOR W/5-10d NAILS. LAMINATE THE SECOND PIECE TO THE FIRST IN A SIMILAR MANNER.
- ⑦ STRAPPING BOARD, 2" X 6" X 36-1/2" (2 REQD).
- ⑧ STRAPPING BOARD ASSEMBLY (2 REQD). SEE DETAIL ON PAGE 9.
- ⑨ HOLD-DOWN STRAP, 2" X .050" OR .044" X 15'-3" LONG STEEL STRAPPING (2 REQD). INSTALL EACH STRAP FROM TWO 7'-8" LONG PIECES. STAPLE TO THE STRAPPING BOARD W/2 STAPLES. DO NOT OVERTENSION THE HOLD-DOWN STRAP.

(CONTINUED AT LEFT)

LOAD AS SHOWN

ITEM	QUANTITY	WEIGHT (APPROX)
CNU-496 CONTAINER	5	22,000 LBS
DUNNAGE		248 LBS

TOTAL WEIGHT - - - - - 22,248 LBS (APPROX)

BILL OF MATERIAL		
LUMBER	LINEAR FEET	BOARD FEET
2" X 6"	101	101
NAILS	NO. REQD	POUNDS
10d (3")	93	1-1/2
20d (4")	30	1-1/4
STEEL STRAPPING, 1-1/4" - 88' REQD - 12-3/4 LBS		
SEAL FOR 1-1/4" STRAPPING - 6 REQD - 1/2 LBS		
STEEL STRAPPING, 2" - - - 77' REQD - - - 26 LBS		
SEAL FOR 2" STRAPPING - - - 32 REQD - 6-1/2 LBS		

SPECIAL NOTES:

1. A FIVE UNIT LOAD IS SHOWN ON A 48'-0" LONG BY 8'-0" WIDE FLATBED TRAILER. LONGER OR WIDER TRAILERS MAY BE USED.
2. IF THE CAPACITY OF MATERIAL HANDLING EQUIPMENT (MHE) IS ADEQUATE, TWO CONTAINERS MAY BE UNITIZED PRIOR TO LOADING ON THE FLATBED TRAILER. IF THIS IS NOT POSSIBLE, THEN THE STACK UNITIZING STRAPS MUST BE POSITIONED AS THE LOADING PROGRESSES.
3. **CAUTION:** THE STRAPPING AND PURCHASE BOARDS AND HOLD-DOWN STRAPS MUST BE IN VERTICAL ALIGNMENT WITH THE TRAILER STAKE POCKET PROVISIONS. SHIFT THE LOAD FORE OR AFT AS NECESSARY TO ACCOMMODATE VARIATIONS IN STAKE POCKET LOCATION.
4. IF WEB STRAPS ARE TO BE USED FOR LOAD SECUREMENT IN LIEU OF THE STEEL HOLD-DOWN STRAPS, REFER TO THE PROCEDURES ON PAGES 4 AND 5 FOR GUIDANCE. IF CHAINS AND LOAD BINDERS ARE TO BE USED FOR LOAD SECUREMENT, REFER TO THE PROCEDURES ON PAGES 6 AND 7 FOR GUIDANCE.
5. THE DEPICTED LOAD CAN BE REDUCED OR INCREASED TO SUIT THE QUANTITY TO BE SHIPPED. A LOAD MAY BE REDUCED OR INCREASED IN MULTIPLES OF TWO CONTAINERS OR ENTIRE LOAD UNITS OF FOUR CONTAINERS. SEE THE DETAILS ON PAGES 4, 6, AND 10 FOR OTHER LOADING CONFIGURATIONS AND QUANTITIES.

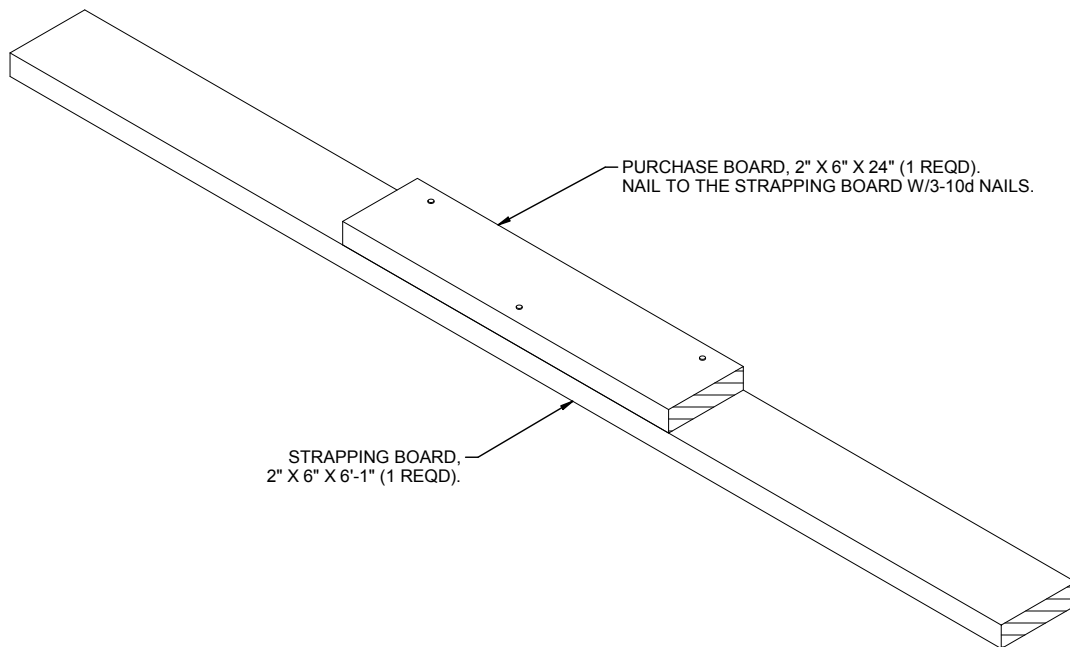

STRAPPING BOARD ASSEMBLY

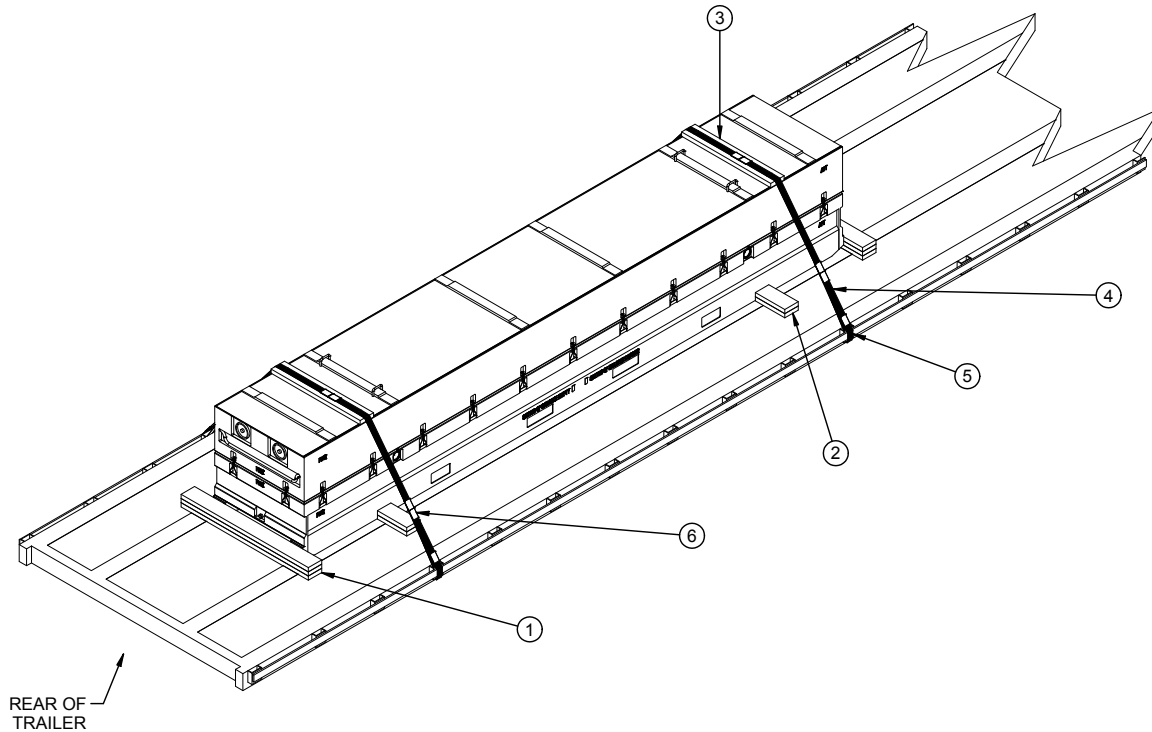

ISOMETRIC VIEW

KEY NUMBERS

- ① HEADER, 2" X 6" X 52" (DOUBLED) (2 REQD). NAIL THE FIRST PIECE TO THE TRAILER FLOOR W/3-10d NAILS. LAMINATE THE SECOND PIECE TO THE FIRST W/3-20d NAILS. LAMINATE THE THIRD PIECE TO THE SECOND W/3-20d NAILS.
- ② SIDE BLOCKING, 2" X 6" X 12" (DOUBLED) (4 REQD). POSITION AGAINST CONTAINER SKID AS SHOWN. NAIL THE FIRST PIECE TO THE TRAILER FLOOR W/4-10d NAILS. LAMINATE THE SECOND PIECE TO THE FIRST IN A SIMILAR MANNER.
- ③ STRAPPING BOARD, 2" X 6" X 36-1/2" (2 REQD)
- ④ HOLD-DOWN STRAP, 2" X .050" OR .044" X 15'-2" LONG STEEL STRAPPING (2 REQD). INSTALL EACH STRAP FROM TWO 7'-7" LONG PIECES. STAPLE TO THE STRAPPING BOARD W/2 STAPLES. DO NOT OVERTENSION THE HOLD-DOWN STRAP.
- ⑤ PAD, 2" X .050" OR .044" X 18" LONG STEEL STRAPPING (4 REQD). POSITION BETWEEN THE HOLD-DOWN STRAP AND THE TRAILER STAKE POCKET AND SEAL TO THE HOLD-DOWN STRAP. SEE "DETAIL A" ON PAGE 11. ALT: STAKE POCKET PROTECTOR (8 REQD). USE TWO UNDER EACH ANCHORING FACILITY WITH A HOLD-DOWN STRAP. SEE "DETAIL B" ON PAGE 11.
- ⑥ SEAL FOR 2" STEEL STRAPPING (16 REQD, 8 PER STRAP). DOUBLE CRIMP EACH SEAL, EXCEPT THOSE USED TO SECURE THE PADS. SEE THE "END-OVER-END LAP JOINT DETAILS" ON PAGE 12.

SPECIAL NOTES:

- 1. A ONE UNIT LTL LOAD IS SHOWN ON A 48'-0" LONG BY 8'-0" WIDE FLATBED TRAILER. OTHER LENGTH AND WIDTH TRAILERS MAY BE USED.
- 2. IF CHAINS AND LOAD BINDERS ARE TO BE USED FOR LOAD SECUREMENT IN LIEU OF THE WEB STRAPPING, REFER TO THE PROCEDURES ON PAGES 6 AND 7 FOR GUIDANCE. IF WEB STRAPS ARE TO BE USED FOR LOAD SECUREMENT, REFER TO THE PROCEDURES ON PAGES 4 AND 5 FOR GUIDANCE.
- 3. THE DEPICTED LOAD CAN BE INCREASED TO SUIT THE QUANTITY TO BE SHIPPED. SEE THE DETAILS ON PAGES 4, 6, AND 8 FOR OTHER LOADING CONFIGURATIONS AND QUANTITIES.

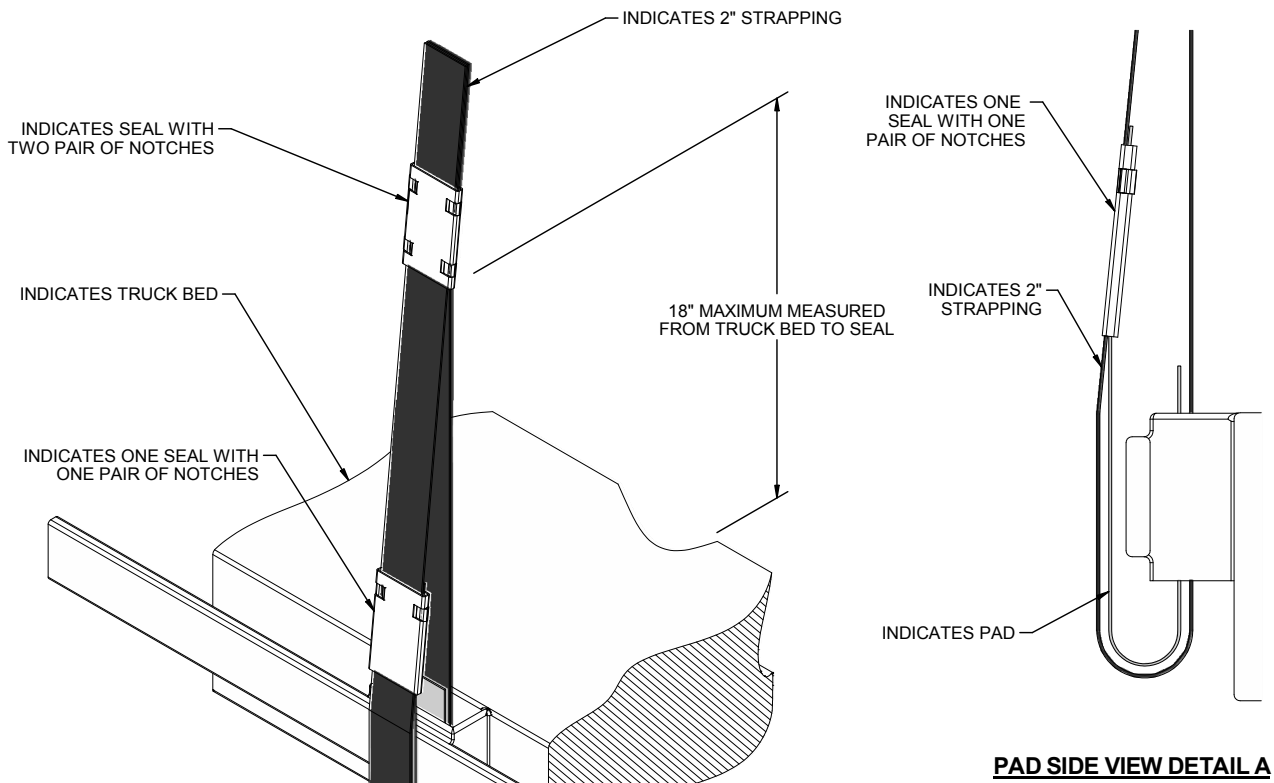

DETAIL A
METHOD OF INSTALLING 2" STRAPPING AND PAD AT ANCHORING FACILITY.

PAD SIDE VIEW DETAIL A

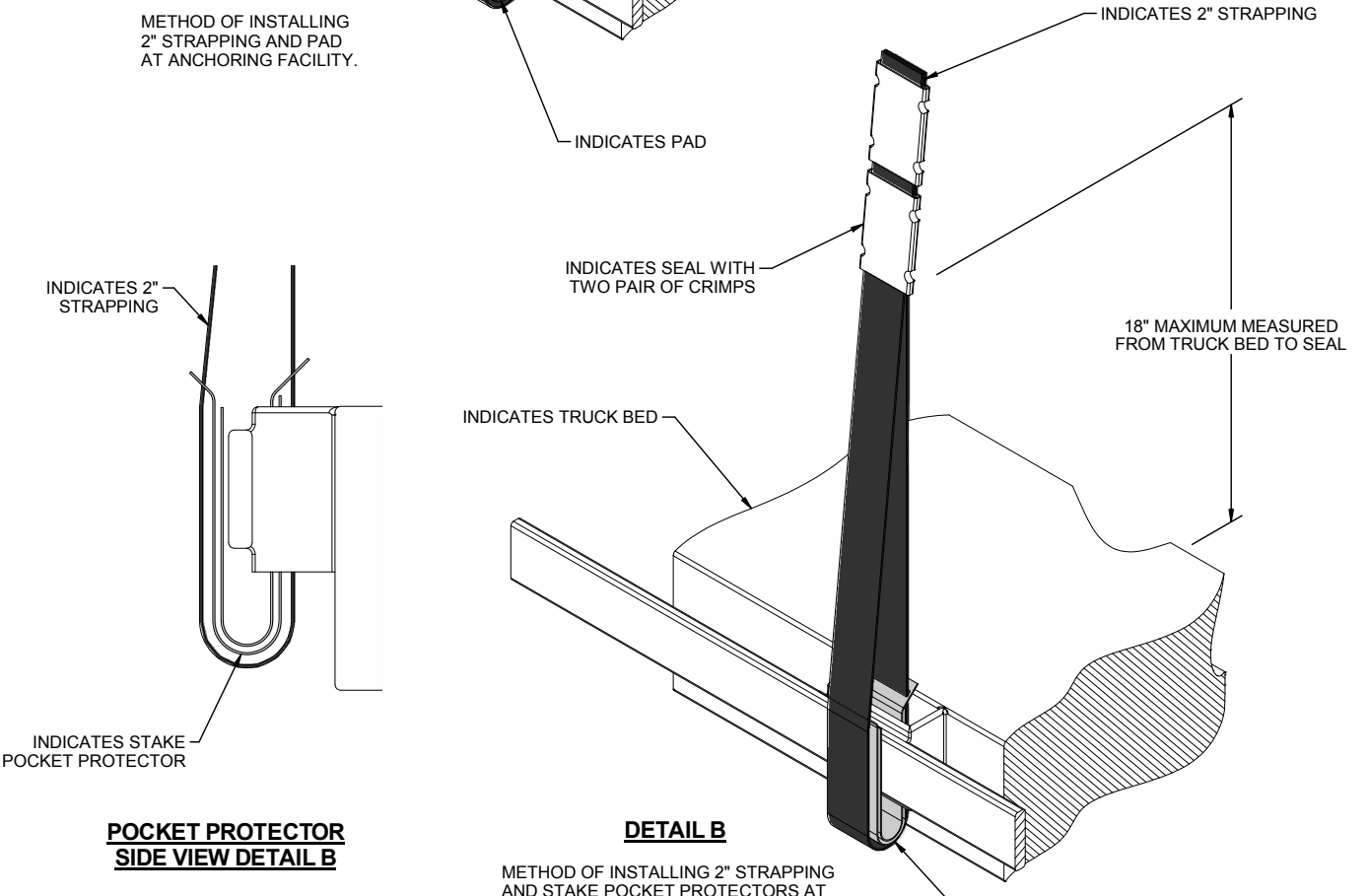

POCKET PROTECTOR SIDE VIEW DETAIL B

DETAIL B
METHOD OF INSTALLING 2" STRAPPING AND STAKE POCKET PROTECTORS AT ANCHORING FACILITY (ALT PAD).

TWO STAKE POCKET PROTECTORS UNDER EACH ANCHORING FACILITY. SEE "POCKET PROTECTOR SIDE VIEW DETAIL B" AT LEFT.

STAKE POCKET STRAP DETAILS

PROVISIONS FOR THE USE OF FIRE HOSE IN LIEU OF CHAIN BOARDS OR STRAPPING BOARDS

FIRE HOSE THAT IS NO LONGER SUITABLE FOR USE IN FIRE FIGHTING APPLICATIONS CAN BE SUBSTITUTED FOR THE DOUBLED 2" BY 6" WOODEN CHAIN BOARDS OR SINGLE 2" BY 6" STRAPPING BOARDS, AS SPECIFIED HEREIN, PROVIDED THE FOLLOWING CONDITIONS ARE MET.

1. SUBSTITUTION AND APPLICATION GUIDANCE
 - A. FIRE HOSE MAY BE USED WHEREVER A CHAIN OR STRAPPING BOARD CONTACTS A RIGID SURFACE OF THE LOAD PROVIDED GOUGING, SCRATCHING, CRACKING, BENDING, CRUSHING, OR OTHER VISIBLE DAMAGE DOES NOT OCCUR TO THE LOAD.
 - B. ONE OR MORE SEGMENTS OF FIRE HOSE MAY BE USED TO REPLACE EACH CHAIN OR STRAPPING BOARD PROVIDING LOAD PROTECTION DURING TENSIONING OF TIEDOWNS AND LOAD SHIPMENT; I.E., A CHAIN BOARD NEED NOT BE REPLACED BY A SINGLE SEGMENT OF HOSE, MULTIPLE SEGMENTS MAY BE USED INSTEAD, AS LONG AS THEY ARE SECURELY FASTENED TO THE TIEDOWN. REGARDLESS OF THE NUMBER OF SEGMENTS USED, THE HOSE LENGTH WILL BE SUCH THAT IT EXTENDS AT LEAST 6" BEYOND THE EDGE OF THE LOAD.
 - C. FIRE HOSE CANNOT BE USED IN PLACE OF A PURCHASE BOARD ON A LOAD CONSISTING OF MORE THAN TWO CONTAINERS ACROSS THE WIDTH OF THE TRAILER. THE FIRE HOSE CAN BE APPLIED TO THE OUTER STACKS, HOWEVER, A PURCHASE BOARD ASSEMBLY WILL STILL BE REQUIRED TO PROVIDE VERTICAL HOLD-DOWN ON THE CENTER STACK(S).
2. ACCEPTABLE FIRE HOSE
 - A. FIRE HOSE TO BE USED WILL BE A RUBBER LINED SINGLE OR DOUBLE JACKETED TYPE; I.E., IT MUST HAVE A RUBBER LINING INSIDE A SINGLE OR DOUBLED FABRIC (COTTON, LINEN, ETC.) JACKET.
 - B. THE COLLAPSED WIDTH OF THE HOSE MUST BE A MINIMUM OF 2-1/2".
 - C. THE HOSE SEGMENTS USED MUST NOT CONTAIN DEFECTS THAT WILL ALLOW DIRECT CONTACT OF THE CHAIN OR LOAD BINDER WITH THE LOAD. THE HOSE THICKNESS MUST ALSO BE OF SUCH A THICKNESS THAT DENTING OR DAMAGE TO THE LOAD DOES NOT OCCUR DURING CHAIN OR STRAP TENSIONING.
3. SECUREMENT TO CHAINS OR STRAPS
 - A. THE SEGMENTS OF HOSE USED UNDER EACH CHAIN OR STRAP WILL BE SECURED TO THE CHAIN OR STRAP WITH ONE FASTENER EVERY 12", WITH A MINIMUM OF TWO FASTENERS REQUIRED PER HOSE SEGMENT.
 - B. FASTENERS CAN CONSIST OF PLASTIC ELECTRICAL TIES, .0800" DIA WIRE, OR TAPE. REGARDLESS OF THE TYPE OF FASTENING USED, IT MUST PROVIDE A POSITIVE MEANS OF SECUREMENT OF THE HOSE TO THE CHAIN OR STRAP AND MUST NOT DAMAGE THE SURFACE OF THE CONTAINER OR ITEM IT CONTACTS.

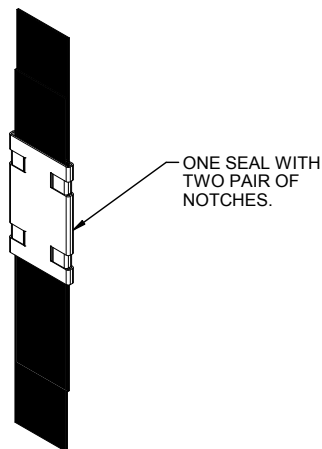

STRAP JOINT A

METHOD OF SECURING A STRAP JOINT WHEN USING A NOTCH-TYPE SEALER.

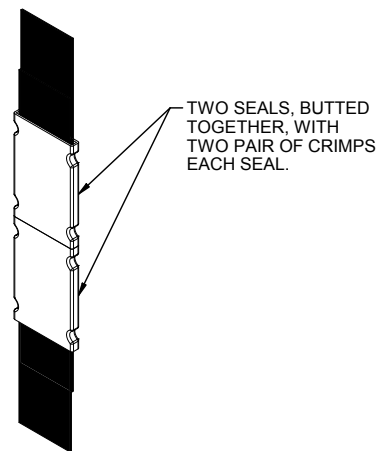

STRAP JOINT B

METHOD OF SECURING A STRAP JOINT WHEN USING A CRIMP-TYPE SEALER.

END-OVER-END LAP JOINT DETAILS