

STORAGE IN APPROVED MAGAZINES OF BLU-109 BOMBS ON MHU-212 METAL PALLETS

<u>I T E M</u>	<u>I N D E X</u>	<u>P A G E (S)</u>
GENERAL NOTES AND MATERIAL SPECIFICATIONS	-	2
PALLET DETAILS	-	3
TYPICAL STORAGE IN ARCHED OR ROUNDED ROOF MAGAZINES	-	4-7
CORBETTA MAGAZINE	-	8, 9
100' -8" L X 50' -0" W RECTANGULAR MAGAZINE	-	10, 11
TYPICAL MULTIPLE-LOT STORAGE PROCEDURES	-	12
FLOOR DUNNAGE AND SHIM LOCATION DETAILS	-	13

U.S. ARMY MATERIEL COMMAND DRAWING

APPROVED U.S. ARMY RESEARCH, DEVELOPMENT AND ENGINEERING COMMAND		CAUTION: VERIFY PRIOR TO USE AT HTTPS://MHP.REDSTONE.ARMY.MIL THAT THIS IS THE MOST CURRENT VERSION OF THIS DOCUMENT. THIS IS PAGE 1 OF 14.				
REHMSTEDT.MARK.J.1230548400 <small>Digitally signed by REHMSTEDT.MARK.J.1230548400 DN: cn=US, ou=U.S. Government, ou=DoD, ou=PKI, ou=USA, cn=REHMSTEDT.MARK.J.1230548400 Date: 2013.12.31 07:17:57 -05'00'</small>	DO NOT SCALE		JULY 2013			
	DESIGN ENGINEER	BASIC REV.	QUYEN TRAN			
SHIMP.UPTON.R.1231257183 <small>Digitally signed by SHIMP.UPTON.R.1231257183 DN: cn=US, ou=U.S. Government, ou=DoD, ou=PKI, ou=USA, cn=SHIMP.UPTON.R.1231257183 Date: 2014.06.12 12:46:48 -05'00'</small>	ENGINEERING DIVISON	FIEFFER.LAURA.A.1230375727 <small>Digitally signed by FIEFFER.LAURA.A.1230375727 DN: cn=US, ou=U.S. Government, ou=DoD, ou=PKI, ou=USA, cn=FIEFFER.LAURA.A.1230375727 Date: 2013.03.28 08:15:46 -05'00'</small>		CLASS	DIVISION	
	TEST ENGINEER	FELICIANO.ADIN.1259200373 <small>Digitally signed by FELICIANO.ADIN.1259200373 DN: cn=US, ou=U.S. Government, ou=DoD, ou=PKI, ou=USA, cn=FELICIANO.ADIN.1259200373 Date: 2013.04.02 13:05:39 -05'00'</small>		DRAWING	FILE	
	EXPLOSIVE SAFETY DIRECTORATE	WILLIAMS.KENYON.N.L.1231212392 <small>Digitally signed by WILLIAMS.KENYON.N.L.1231212392 DN: cn=US, ou=U.S. Government, ou=DoD, ou=PKI, ou=USA, cn=WILLIAMS.KENYON.N.L.1231212392 Date: 2013.04.29 15:22:51 -05'00'</small>		19	48	8773
U.S. ARMY DEFENSE AMMUNITION CENTER						

GENERAL NOTES

- A. THIS DOCUMENT HAS BEEN PREPARED AND ISSUED IN ACCORDANCE WITH AR 740-1 AND AUGMENTS TM 743-200-1 (CHAPTER 5).
- B. THE STORAGE PROCEDURES DEPICTED WITHIN THIS DOCUMENT ARE APPLICABLE FOR STORAGE IN VARIOUS TYPES AND SIZES OF MAGAZINES. THE STORAGE PROCEDURES DEPICTED FOR THE SPECIFIC TYPES OF MAGAZINES MAY ALSO BE UTILIZED TO STORE BLU-109 BOMBS ON MHU-212 METAL PALLETS IN OTHER TYPES OF APPROVED MAGAZINES. MINOR ADJUSTMENTS MAY BE MADE TO FACILITATE STORAGE IN OTHER TYPES OF MAGAZINES; HOWEVER, THE BASIC PRINCIPLES AS DEPICTED HEREIN WILL BE FOLLOWED.
- C. THE STORAGE PROCEDURES SPECIFIED IN THIS DRAWING ARE APPLICABLE TO BLU-109 BOMBS ON MHU-212 METAL PALLETS. SUBSEQUENT REFERENCE TO PALLET UNIT HEREIN MEANS PALLET UNIT WITH AMMUNITION ITEMS. SEE PAGE 3 AND NAVAL SEA SYSTEMS COMMAND DRAWING 6214303 FOR DETAILS OF THE PALLET UNIT.
- D. **CAUTION:** THE ALLOWABLE "EXPLOSIVE LIMIT" ESTABLISHED FOR A MAGAZINE IS NOT TO BE EXCEEDED. THIS LIMITATION MAY REQUIRE A QUANTITY REDUCTION FROM THE STORAGE AS SHOWN.
- E. STORED PALLET UNITS MUST NOT CONTACT THE SIDES OF A MAGAZINE. THEREFORE, PALLET UNITS MUST BE STORED A MINIMUM OF 6" FROM THE SIDEWALL OR CURVATURE OF THE MAGAZINE AS APPLICABLE. TO PROVIDE FOR THIS MANDATORY CLEARANCE REQUIREMENT, PALLET UNITS MAY BE ELIMINATED FROM THE DEPICTED STORAGE PATTERN AS NECESSARY.
- F. AISLE DIMENSION SHOWN FOR STORAGE PROCEDURES IN MAGAZINES MAY BE ADJUSTED TO SUIT LOCAL CONDITIONS, VARIATIONS IN PALLET UNIT DIMENSIONS, AND/OR AVAILABLE MATERIAL HANDLING EQUIPMENT (MHE). HOWEVER, A 24" MINIMUM INSPECTION AISLE MUST BE MAINTAINED TO FACILITATE INSPECTION.
- G. THE MAXIMUM FLOOR LOAD FOR A MAGAZINE AS PRESCRIBED WILL NOT BE EXCEEDED.
- H. IF AVAILABLE MHE PERMITS, ADDITIONAL PALLET UNITS MAY BE STORED WITHIN THE MHE AREA AND/OR OTHER AVAILABLE AREA OF THE MAGAZINE.
- J. THE HEIGHT OF THE PACKAGE GUARD ON SOME FORKLIFT TRUCKS MAY NOT PERMIT PLACEMENT OF SOME TOP LAYER PALLET UNITS IN THE STACKS SHOWN IN THE STORAGE VIEWS HEREIN, UNLESS TWO UPPER PALLET UNITS ARE HANDLED AS ONE LIFT OR THE PACKAGE GUARD IS REMOVED (TINE CARRIAGE WILL IN MOST INSTANCES PROVIDE ADEQUATE PACKAGE GUARD PROTECTION). ONLY A FORKLIFT TRUCK OF ADEQUATE CAPACITY WILL BE USED WHEN LIFTING TWO PALLET UNITS AS ONE LIFT.
- K. THE USE OF "FLOOR DUNNAGE" IS OPTIONAL, ALTHOUGH THE USE OF THIS TYPE OF DUNNAGE IS DELINEATED WITHIN THIS STORAGE PROCEDURE DRAWING. THE PURPOSE OF FLOOR DUNNAGE IS TO KEEP THE BOTTOM DECKBOARDS OF THE PALLET DRY, THUS AIDING IN PREVENTING DETERIORATION DUE TO OXIDATION (RUSTING). THEREFORE, FLOOR DUNNAGE SHOULD BE USED WHEN STORING IN A MAGAZINE THAT IS KNOWN TO HAVE A "DAMP" FLOOR. ALSO, IN LIEU OF USING ONE-INCH THICK FLOOR DUNNAGE AS SPECIFIED, THE USE OF THICKER FLOOR DUNNAGE MAY BE REQUIRED, AND SHOULD BE USED, TO ACHIEVE THE DESIRED OBJECTIVE. **NOTE:** SOME VIEWS WITHIN THIS DRAWING WILL NOT DEPICT ALL FLOOR DUNNAGE THAT IS REQUIRED WHEN DUNNAGE IS USED. FLOOR DUNNAGE IS SHOWN AT SOME LOCATIONS TO PROVIDE POSITIONING GUIDANCE.

(CONTINUED AT RIGHT)

(GENERAL NOTES CONTINUED)

- L. WHEN LOCAL STORAGE CONDITIONS ARE SUCH THAT AN AMMUNITION STORAGE MAGAZINE NET EXPLOSIVE WEIGHT LIMIT WILL BE REACHED BEFORE ALL AVAILABLE STORAGE SPACE WILL BE UTILIZED, A COMBINATION OF THE VARIOUS STORAGE PATTERNS DELINEATED HEREIN MAY BE USED IN LIEU OF BLOCK STORAGE PATTERNS TO FACILITATE INVENTORY, INSPECTION, THE USE OF MATERIAL HANDLING EQUIPMENT, SURVEILLANCE, ETC., OF THE AMMUNITION TO BE STORED WITHIN THE MAGAZINE.
- M. STORAGE OF MULTIPLE LOTS IN A MAGAZINE WILL REQUIRE CAREFUL PREPLANNING SO AS TO INSURE MHE ACCESSIBILITY TO ANY LOT IN ACCORDANCE WITH REQUIREMENTS SET FORTH IN THE APPLICABLE "SPECIAL NOTES" SECTIONS OF THE MULTIPLE LOT STORAGE PROCEDURES SHOWN ON PAGE 12.
- N. ALTHOUGH SPECIFIC PROCEDURES ARE INCLUDED IN THIS DRAWING FOR STORING MULTIPLE LOTS WITHIN ONE STRUCTURE, THE BASIC STORAGE PATTERN AS SHOWN ON PAGES 4 THRU 11 CAN ALSO BE ADAPTED FOR STORAGE MORE THAN ONE LOT, LOTS WHEN STORED IN ACCORDANCE WITH THE BASIC STORAGE PATTERN MAY BE STORED WITH ONE OR MORE ROWS USED FOR EACH LOT. A SPACE OF APPROXIMATELY 1" WILL HAVE TO BE LEFT BETWEEN ADJACENT ROWS CONTAINING DIFFERENT LOTS. IN BASIC STORAGE PATTERNS WHERE THE WIDTH OF A ROW IS ESTABLISHED BY THE 38" CONTAINER DIMENSION, EACH ROW MAY BE A DIFFERENT LOT AND READILY REMOVABLE. IN BASIC STORAGE PATTERNS WHERE THE WIDTH OF THE ROW IS ESTABLISHED BY THE 70" CONTAINER DIMENSION, A LOT MUST CONSIST OF TWO OR MORE ROWS TO PROVIDE ADEQUATE SPACE TO ACCOMMODATE THE WIDTH OF A FORKLIFT TRUCK FOR STORING OR REMOVING THE LOT. THE 1" SPACE BETWEEN LOTS, AS STATED ABOVE WILL NOT BE EXCEEDED SOLELY TO ACCOMMODATE THE WIDTH OF A FORKLIFT TRUCK. FOR ADDITIONAL REQUIREMENTS AND GUIDANCE, SEE SPECIAL NOTES FOR MULTIPLE-LOT STORAGE ON PAGE 12.
- O. ANY "LIGHT" PALLET UNIT THAT DOES NOT CONTAIN A FULL QUANTITY WILL NOT BE BURIED IN STORAGE, IT MUST BE POSITIONED ADJACENT TO AN AISLE.
- P. PALLET UNITS PRESENTLY STORED IN ACCORDANCE WITH A PRIOR APPROVED DRAWING NEED NOT BE RE-STORED SOLELY TO CONFORM TO THE PROCEDURES SPECIFIED IN THIS DOCUMENT.
- Q. OTHER COMPATIBLE ITEMS MAY BE STORED IN A MAGAZINE, WHICH IS PARTIALLY FILLED WITH THE DESIGNATED ITEM.
- R. IN IGLOO, ARCH TYPE AND STRADLEY MAGAZINES WHICH HAVE SLOPING FLOORS, THE DEPICTED STORAGE PATTERNS, IN SOME CASES, INCLUDE PALLET UNIT STACKS WHICH STRADDLE THE RIDGE OF THE FLOOR AT THE CENTER OF THE MAGAZINE. FLOOR DUNNAGE IN THE FORM OF SHIMS WILL BE USED AS REQUIRED TO ACHIEVE SOUND AND ACCEPTABLE STABLE STACKS. SEE THE DETAIL ON PAGE 12.
- S. PORTIONS OF THE MAGAZINES, SUCH AS SIDEWALLS, END WALLS, AND ROOFS HAVE NOT BEEN SHOWN IN THE STORAGE VIEWS FOR CLARITY PURPOSES.
- T. DUNNAGE LUMBER SPECIFIED THROUGHOUT THIS PROCEDURAL DRAWING IS OF NOMINAL SIZE. FOR EXAMPLE, 1" X 4" MATERIAL IS ACTUALLY 3/4" THICK BY 3-1/2" WIDE AND 2" X 6" MATERIAL IS ACTUALLY 1-1/2" THICK BY 5-1/2" WIDE.
- U. CONVERSION TO METRIC EQUIVALENTS: DIMENSIONS WITHIN THIS DOCUMENT ARE EXPRESSED IN INCHES, AND WEIGHTS ARE EXPRESSED IN POUNDS. WHEN NECESSARY, THE METRIC EQUIVALENT MAY BE COMPUTED ON THE BASIS OF ONE INCH EQUALS 25.4MM, AND ONE POUND EQUALS 0.454 KG.

MATERIAL SPECIFICATIONS

LUMBER - - - - - : SEE TM 743-200-1 (DUNNAGE LUMBER) AND VOLUNTARY PRODUCT STANDARD PS 20.

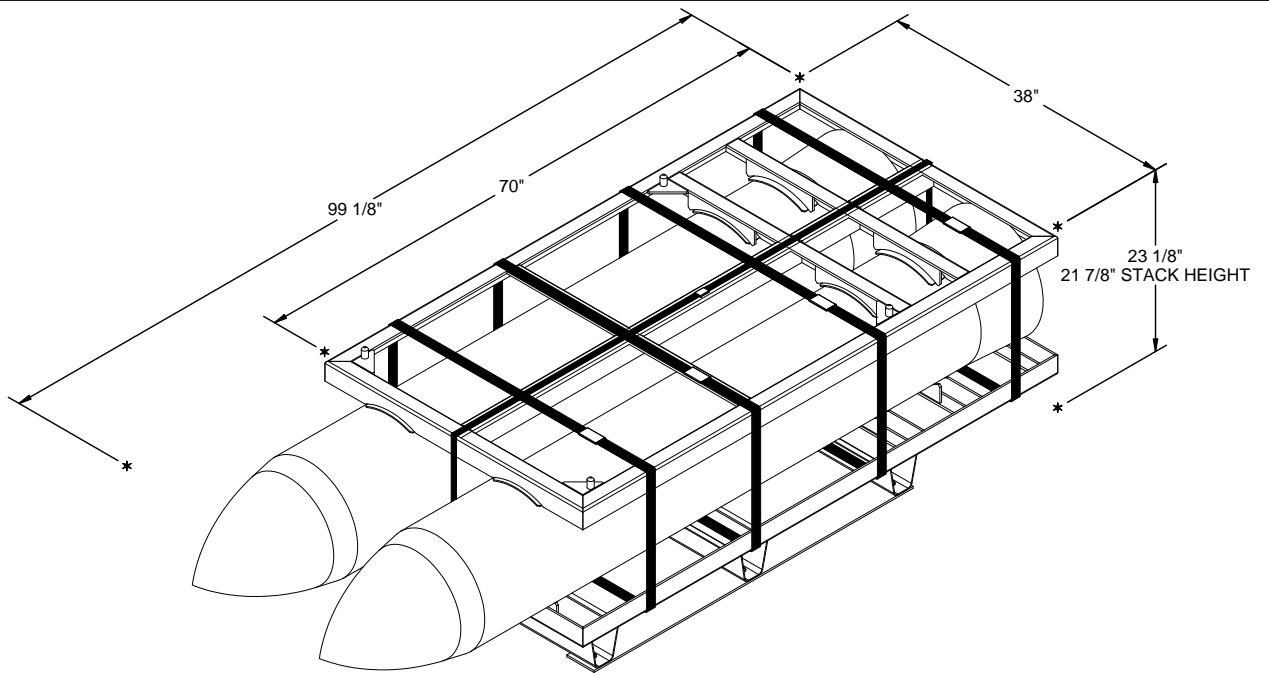

BLU-109 ON MHU-212 PALLET

GROSS WEIGHT - - - - - 4,323 LBS (APPROX)
 VOLUME - - - - - 47.7 CU FT (APPROX)

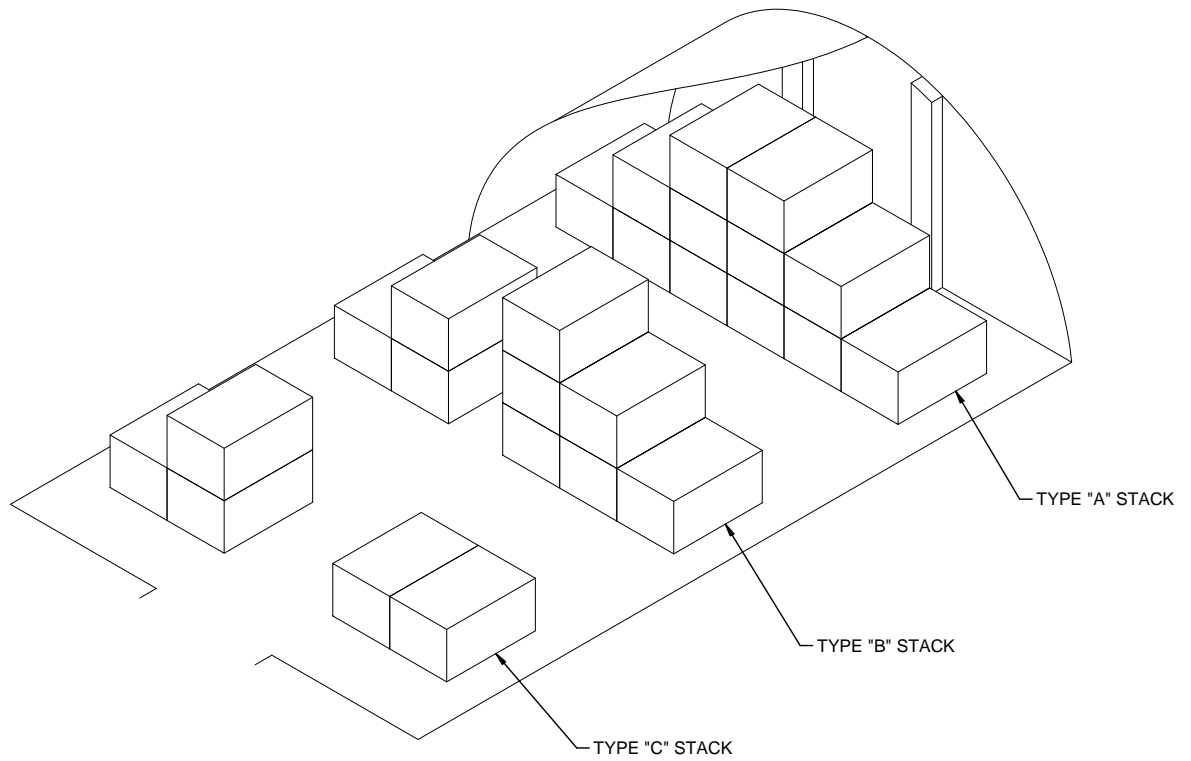

STACK IDENTIFICATION

A TYPE "A" STACK IS IDENTIFIED AS A GROUP OF ITEMS /UNITS WHICH EXTENDS FULL WIDTH AND HEIGHT OF THE MAGAZINE, AND IS ONE ITEM/UNIT LONG IN THE LENGTH OF THE MAGAZINE.

A TYPE "B" STACK IS IDENTIFIED AS A GROUP OF ITEMS/UNITS WHICH EXTEND FULL WIDTH AND HEIGHT OF THE MAGAZINE, AND IS ONE UNIT/ITEM LONG, BUT HAS AN AISLE AT OR NEAR THE CENTER OF THE WIDTH OF THE STACK.

A TYPE "C" STACK IS IDENTIFIED AS A GROUP OF ITEMS/UNITS WHICH IS ONE UNIT/ITEM LONG AND CONSISTS OF PARTIAL STACKS ON EACH SIDE OF THE MAGAZINE, USUALLY ONE ITEM/UNIT HIGH ON ONE SIDE OF THE MAGAZINE.

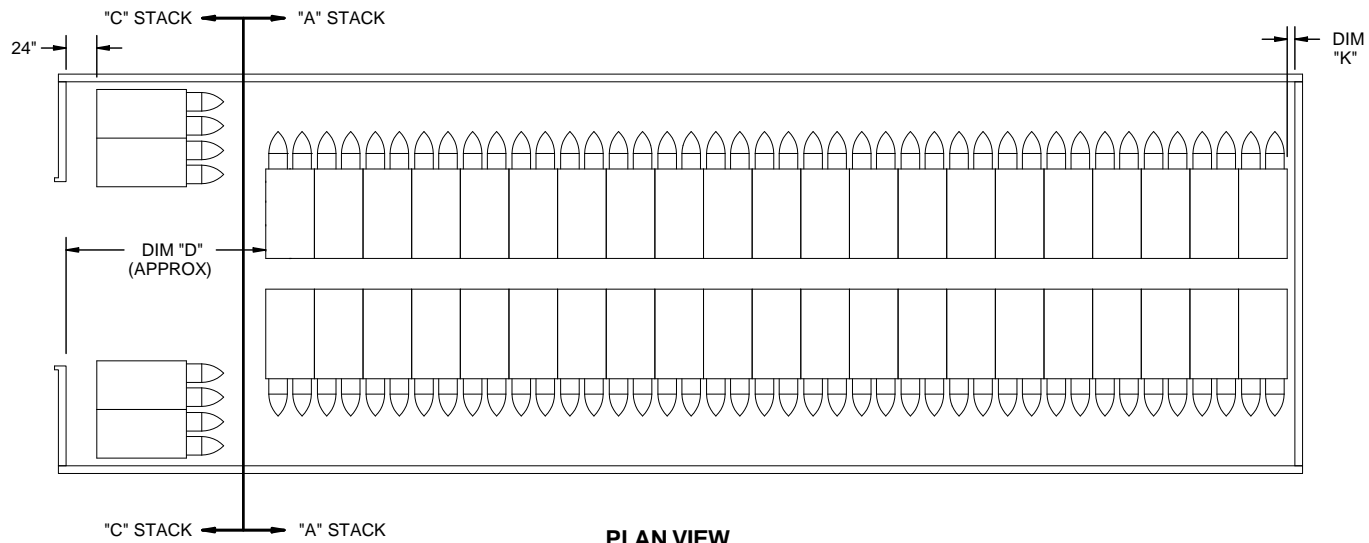

PLAN VIEW

NOTE: FOR IDENTIFICATION OF LETTERED DIMENSIONS REFER TO CHART 1 ON PAGE 6.

STACK COLUMN DESIGNATIONS

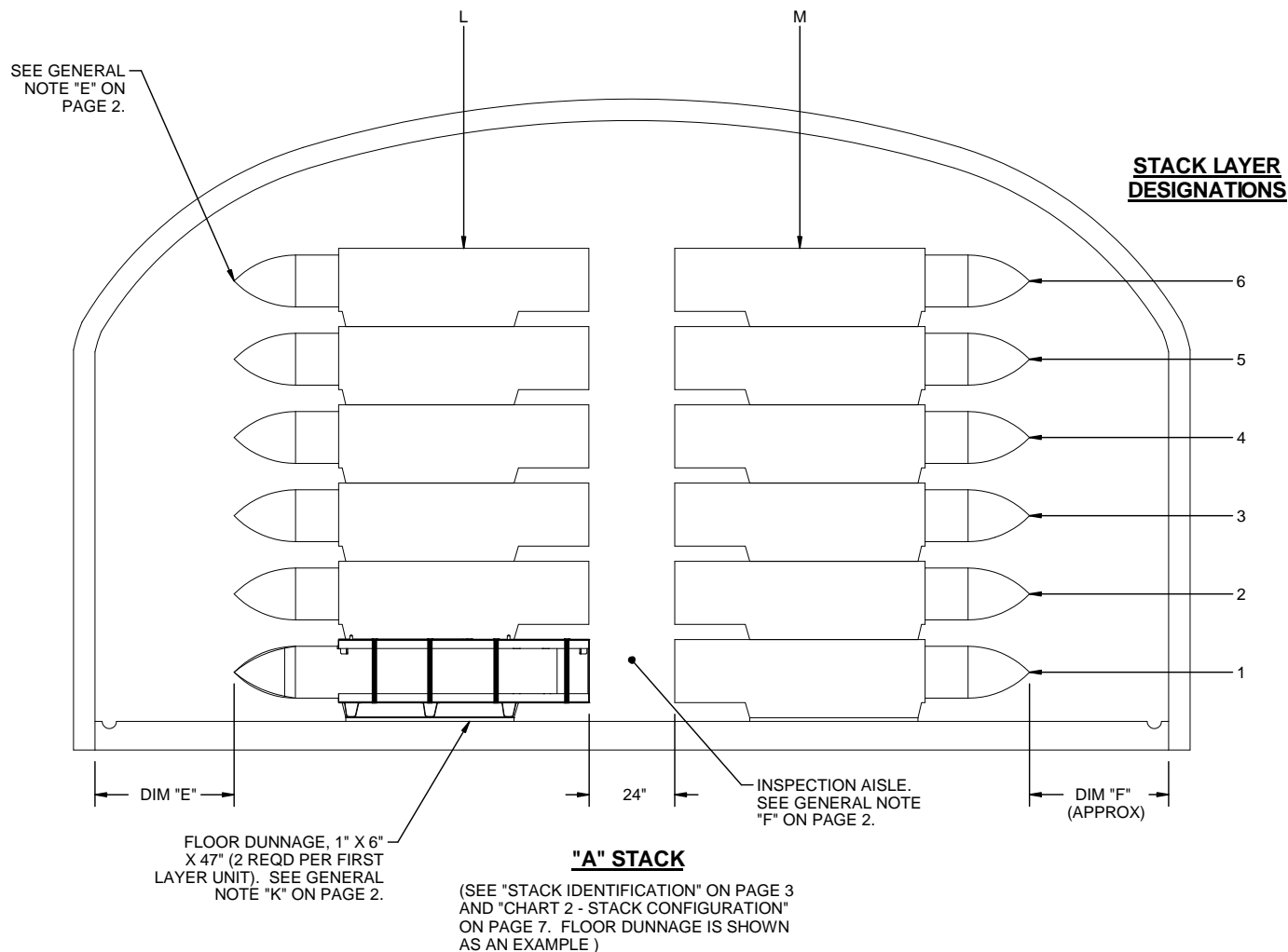

"A" STACK

(SEE "STACK IDENTIFICATION" ON PAGE 3 AND "CHART 2 - STACK CONFIGURATION" ON PAGE 7. FLOOR DUNNAGE IS SHOWN AS AN EXAMPLE)

NOTE: FOR IDENTIFICATION OF LETTERED DIMENSIONS REFER TO CHART 1 ON PAGE 6.

STACK COLUMN DESIGNATIONS

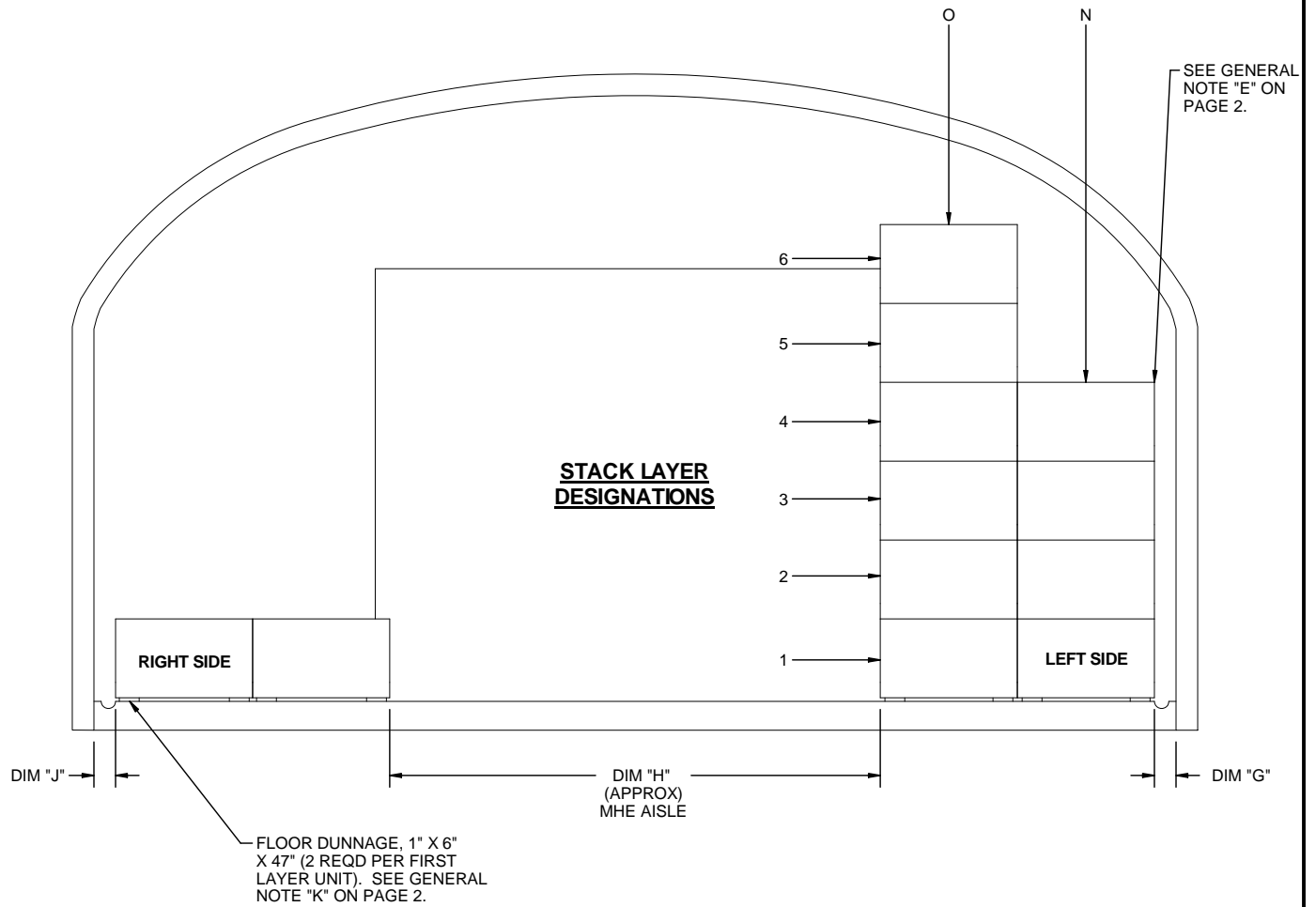

"C" STACK

TYPICAL "C" STACK FOR STRADLEY MAGAZINE.
(SEE "STACK IDENTIFICATION" ON PAGE 3 AND
"CHART 2 - STACK CONFIGURATION" ON PAGE 7)

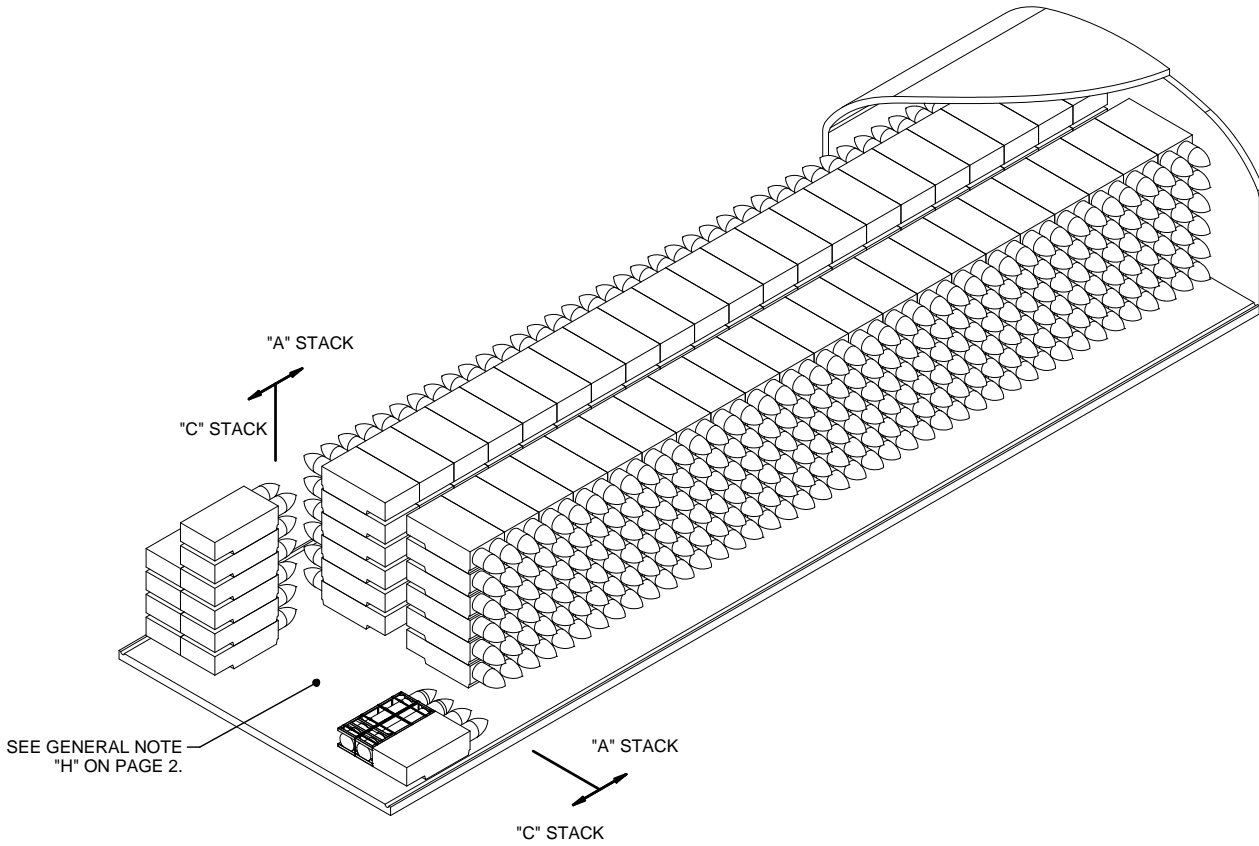

ISOMETRIC VIEW

STRADLEY MAGAZINE SHOWN AS TYPICAL.

CHART 1 - DIMENSIONS

MAGAZINE DIMENSIONS	MAGAZINE TYPE															
	IGLOO			ARCH 12'			ARCH 11'		ARCH 10'		OVAL ARCH	STRADLEY	STEEL ARCH			
	40'-4"	60'-8"	81'-0"	26'-6"	26'-6"	26'-6"	40'-0"	80'-0"	40'-0"	80'-0"	40'-0"	80'-0"	89'-0"	80'-0"	59'-0"	89'-0"
LENGTH	40'-4"	60'-8"	81'-0"	26'-6"	40'-0"	80'-0"	40'-0"	80'-0"	40'-0"	80'-0"	89'-0"	80'-0"	59'-0"	89'-0"		
WIDTH		26'-6"		26'-6"	25'-0"	25'-0"	25'-0"		25'-0"		24'-10"	25'-0"	25'-0"	25'-0"	24'-11"	
HEIGHT		12'-9"		12'-1-3/4"			11'-0"		10'-0"		14'-5"	14'-0"	14'-0"	14'-0"	13'-6"	
DIMENSIONS	PALLET UNIT SPACING DIMENSIONS															
DIM "D" (M HE AREA APPROX)	14'-6"	12'-8"	14'-0"	13'-6"	14'-2"	12'-4"	13'-6"	12'-4"	14'-2"	13'-0"	12'-6"	13'-0"	14'-2"	12'-6"		
DIM "E" ("A" STACK LEFT)	48"	48"	48"	48"	39"	39"	39"	39"	39"	39"	38"	39"	39"	38"		
DIM "F" ("A" STACK RIGHT)	48"	48"	48"	48"	39"	39"	39"	39"	39"	39"	38"	39"	39"	38"		
DIM "G" ("C" STACK LEFT)	24"	24"	24"	33"	30"	26"	30"	30"	30"	30"	6"	6"	12"	14"		
DIM "H" (M HE AISLE APPROX)	11'-2"	11'-2"	11'-2"	13'-0"	12'-2"	12'-6"	11'-9"	11'-9"	11'-9"	11'-9"	11'-2"	11'-4"	10'-10"	13'-9"		
DIM "J" ("C" STACK RIGHT)	8"	8"	8"	15"	10"	10"	15"	15"	15"	15"	6"	6"	6"	6"		
DIM "K" ("A" STACK BACK)	6"	6"	6"	14"	6"	14"	14"	14"	6"	6"	6"	6"	6"	6"		

CHART 2 - STACK CONFIGURATION

MAGAZINE TYPE														
QUANTITY PER MAGAZINE	IGLOO			ARCH 12'	ARCH 12' X 25' W		ARCH 11'		ARCH 10'		OVAL ARCH	STRADLEY	STEEL ARCH	
	40'-4" L	60'-8" L	81'-0" L	26'-6" W	40'-0" L	80'-0" L	40'-0" L	80'-0" L	40'-0" L	80'-0" L			59'-0" L	89'-0" L
	74	130	178	177	73	177	55	133	55	133	301	264	150	249

"A" STACK CONFIGURATION

LAYER	PALLET UNITS PER LAYER													
1	2(L-M)			2(L-M)	2(L-M)		2(L-M)		2(L-M)		2(L-M)	2(L-M)	2(L-M)	
2	2(L-M)			2(L-M)	2(L-M)		2(L-M)		2(L-M)		2(L-M)	2(L-M)	2(L-M)	
3	2(L-M)			2(L-M)	2(L-M)		2(L-M)		2(L-M)		2(L-M)	2(L-M)	2(L-M)	
4	2(L-M)			2(L-M)	2(L-M)		0		0		2(L-M)	2(L-M)	2(L-M)	
5	0			0	0		0		0		2(L-M)	2(L-M)	2(L-M)	
6	0			0	0		0		0		2(L-M)	2(L-M)	0	
SINGLE STACK TOTAL	8			8	8		6		6		12	12	10	
NUMBER OF STACKS	8	15	21	21	8	21	8	21	8	21	24	21	14	24
"A" STACK TOTAL	64	120	168	168	64	168	48	126	48	126	288	252	140	240

"C" STACK CONFIGURATION - LEFT SIDE

LAYER	PALLET UNITS PER LAYER													
1	2(N-O)			2(N-O)		2(N-O)		2(N-O)		2(N-O)	2(N-O)	2(N-O)	2(N-O)	
2	2(N-O)			2(N-O)		2(N-O)		2(N-O)		2(N-O)	2(N-O)	2(N-O)	2(N-O)	
3	2(N-O)			2(N-O)		1(O)		1(O)		2(N-O)	2(N-O)	2(N-O)		
4	1(O)			1(O)		1(O)		1(O)		2(N-O)	2(N-O)	1(O)		
5	1(O)			1(O)		0		0		2(N-O)	1(O)	1(O)		
6	0			0		0		0		1(O)	1(O)	0		
SINGLE STACK TOTAL	8			8		6		6		11	10	8		
NUMBER OF STACKS	1			1		1		1		1	1	1		
"C" STACK LF TOTAL	8			8		6		6		11	10	8		

"C" STACK CONFIGURATION - RIGHT SIDE

"C" STACK RT TOTAL	2			1		1		1		2	2	2	1
--------------------	---	--	--	---	--	---	--	---	--	---	---	---	---

NOTE: REFER TO THE SPECIAL NOTES BELOW.

SPECIAL NOTES:

- THE FOLLOWING NOTES, CHART 1 ON PAGE 6 AND CHART 2 ABOVE ARE PRESENTED AS GUIDANCE IN THE SELECTION OF A STORAGE PATTERN, AND IN DETERMINING THE QUANTITY OF PALLET UNITS WHICH CAN BE STORED IN THE STORAGE MAGAZINES LISTED IN THE CHARTS MENTIONED ABOVE.
- CHART 1 ON PAGE 6 DESCRIBES THE STORAGE MAGAZINE GENERAL DIMENSIONS AND THE DIMENSIONS OF THE PALLET UNIT SPACING WITHIN THE STORAGE MAGAZINES.
- DIMENSIONS "A", "B" AND "C" HAVE BEEN OMITTED TO AVOID CONFUSION WITH STACKS "A", "B" AND "C".
- CHART 2 ABOVE DETAILS THE QUANTITY OF PALLET UNITS IN EACH TYPE OF MAGAZINE AND THE LAYOUT OF THE STACKS FOR EACH TYPE OF MAGAZINE. THE CHART SHOWS THE NUMBER OF PALLET UNITS IN EACH STACK LAYER AND THE LOCATION OF THE PALLET ON EACH LAYER.

(CONTINUED AT RIGHT)

EXAMPLE:

CHART 2 – "C" STACK CONFIGURATION - LEFT SIDE
MAGAZINE: STRADLEY

- LAYER NUMBER 1: 2 (N-O)
- LAYER NUMBER 2: 2 (N-O)
- LAYER NUMBER 3: 2 (N-O)
- LAYER NUMBER 4: 2 (N-O)
- LAYER NUMBER 5: 1 (O)
- LAYER NUMBER 6: 1 (O)

EXPLANATION:

LAYER 1 (BOTTOM LAYER) HAS TWO PALLET FROM THE "N" COLUMN (NEAREST THE LEFT SIDE OF THE MAGAZINE) TO THE "O" COLUMN.

LAYER 2 (ON TOP OF LAYER 1) HAS TWO PALLET FROM THE "N" COLUMN (NEAREST THE LEFT SIDE OF THE MAGAZINE) TO THE "O" COLUMN.

LAYER 3 (ON TOP OF LAYER 2) HAS TWO PALLET FROM THE "N" COLUMN (NEAREST THE LEFT SIDE OF THE MAGAZINE) TO THE "O" COLUMN.

LAYER 4 (ON TOP OF LAYER 3) HAS TWO PALLET FROM THE "N" COLUMN (NEAREST THE LEFT SIDE OF THE MAGAZINE) TO THE "O" COLUMN.

LAYER 5 (ON TOP OF LAYER 4) HAS ONE PALLET AT THE "O" COLUMN.

LAYER 6 (ON TOP OF LAYER 5) HAS ONE PALLET AT THE "O" COLUMN.

STORAGE IN 44'-7" MAGAZINE

STORAGE IN 52'-0" MAGAZINE

ITEM	QUANTITY
PALLET UNIT	----- 144

ITEM	QUANTITY
PALLET UNIT	----- 222

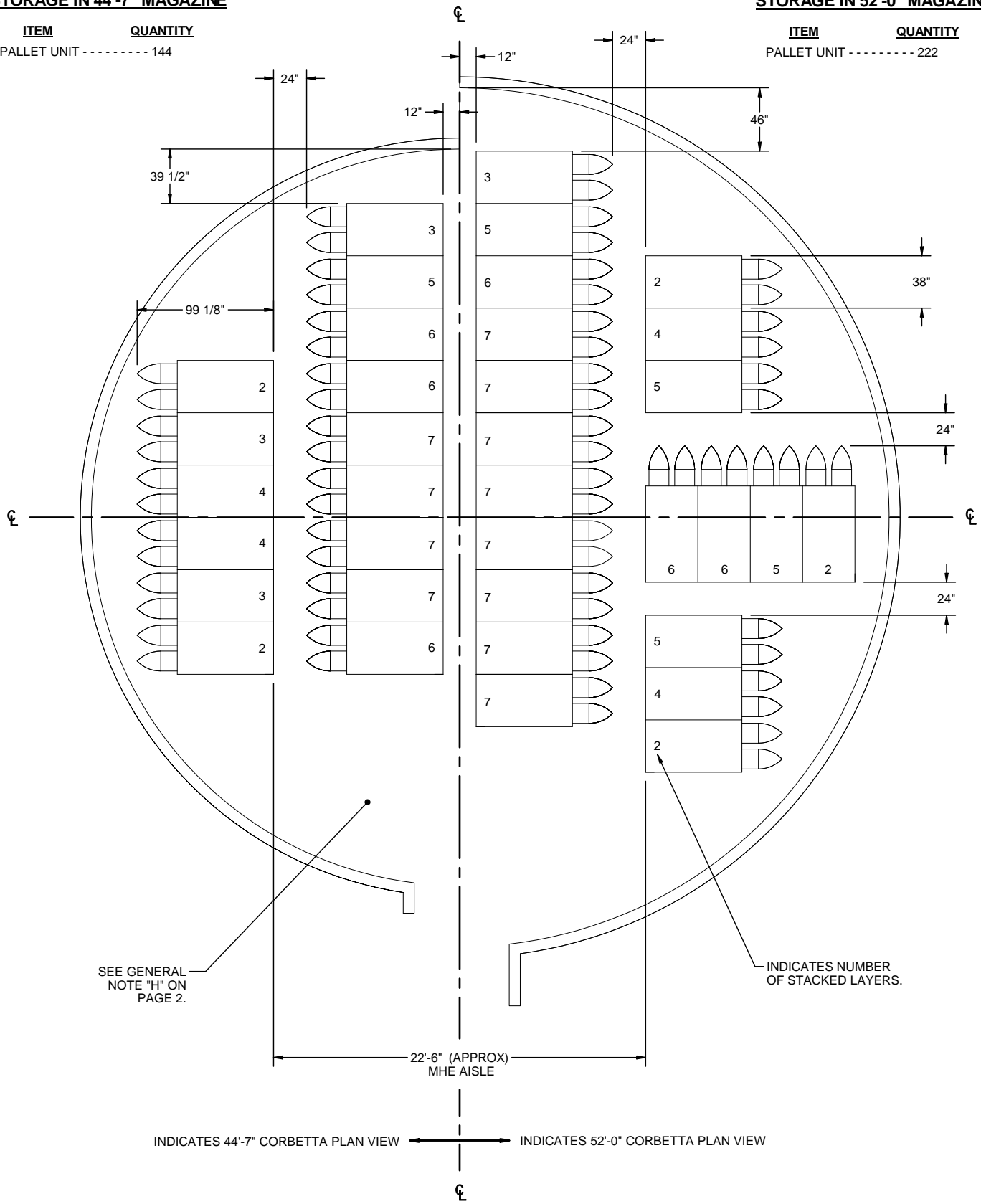

PLAN VIEW

THE RIGHT HAND PLAN VIEW INDICATES A 52'-0" CORBETTA MAGAZINE, AND THE LEFT HAND PLAN VIEW INDICATES A 44'-7" CORBETTA MAGAZINE. BOTH SIZE MAGAZINE LAYOUTS ARE SYMMETRICAL AROUND THE VERTICAL CENTER LINE.

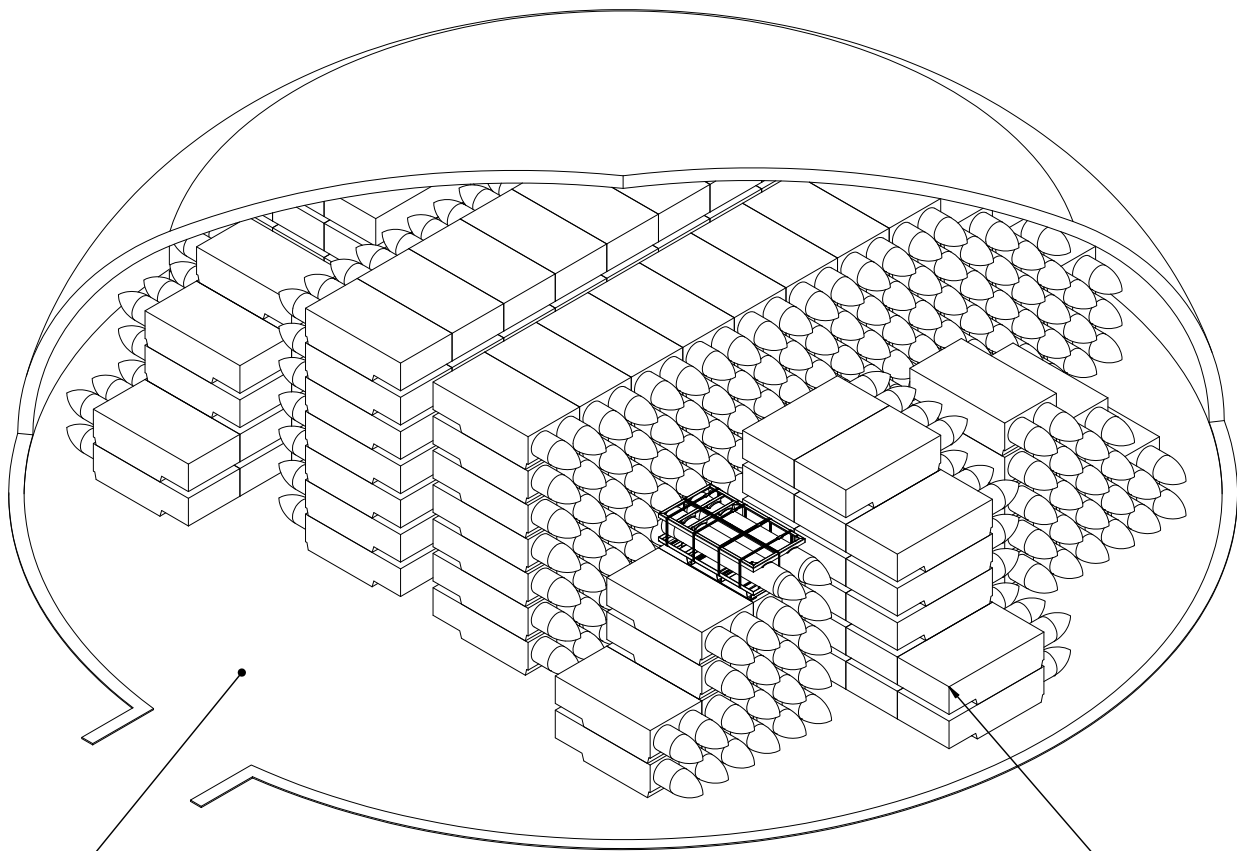

SEE GENERAL
NOTE "H" ON
PAGE 2.

SEE GENERAL
NOTE "E" ON
PAGE 2.

ISOMETRIC VIEW
(52' - 0" DIA MAGAZINE)

**STORAGE IN RECTANGULAR
MAGAZINE**

ITEM **QUANTITY**
PALLET UNIT ----- 698

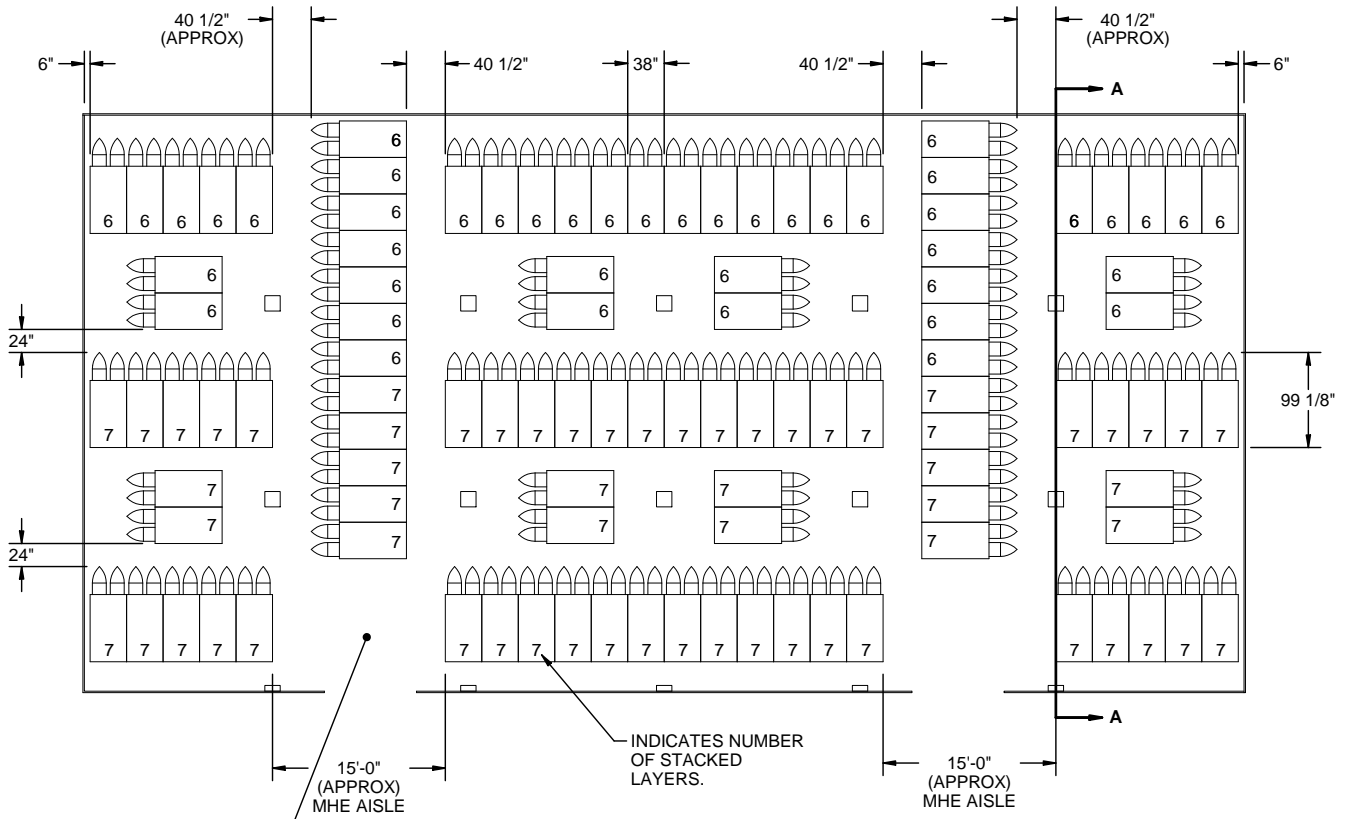

SEE GENERAL NOTE
"H" ON PAGE 2.

PLAN VIEW

SEE GENERAL NOTE
"E" ON PAGE 2.

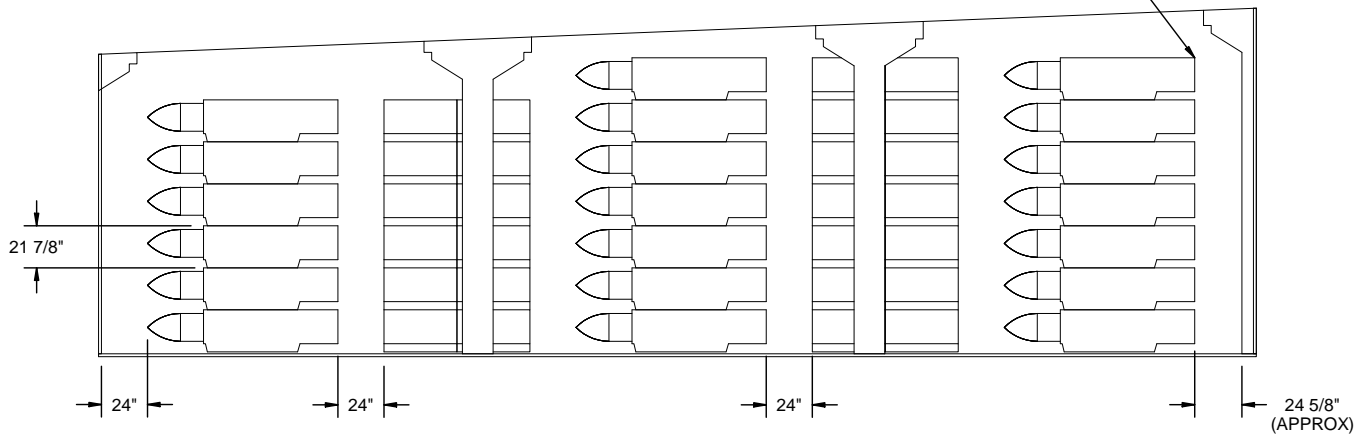

SECTION A-A

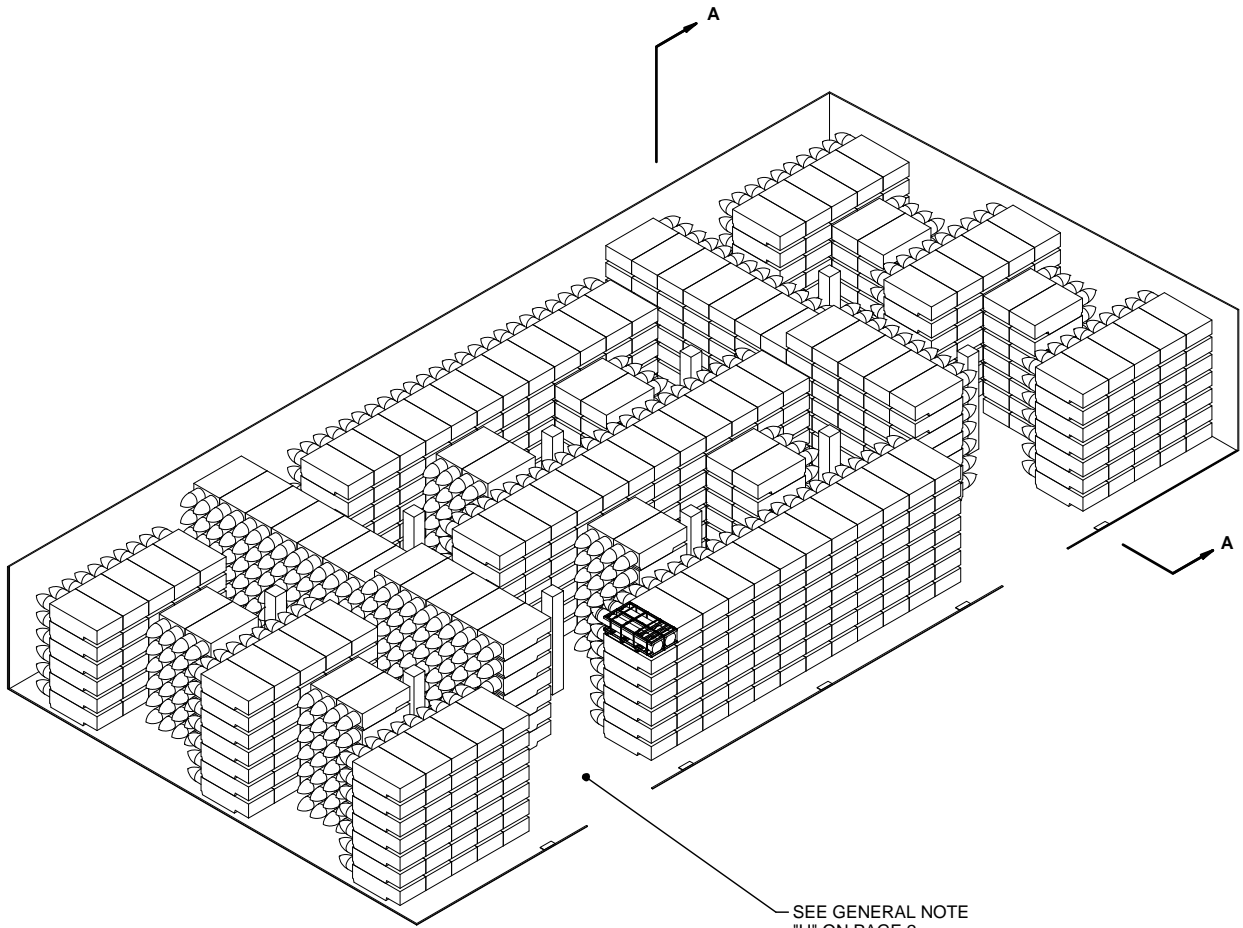

SEE GENERAL NOTE
"H" ON PAGE 2.

ISOMETRIC VIEW

(50'-0" MAGAZINE)

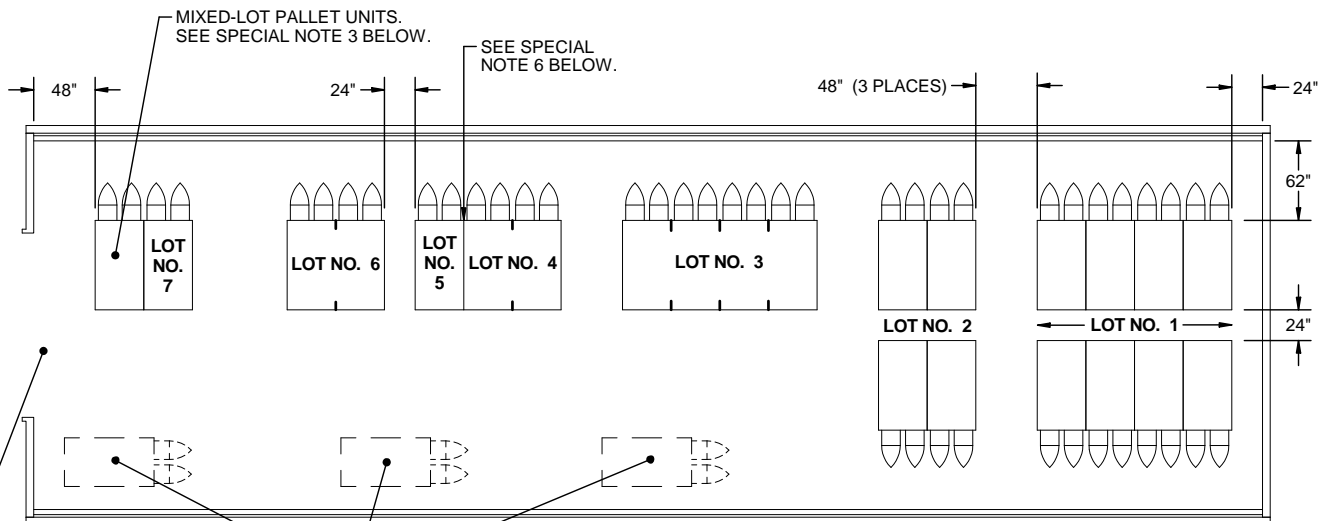

SEE GENERAL NOTE "H" ON PAGE 2.

SEE SPECIAL NOTE 7 BELOW.

PLAN VIEW

SPECIAL NOTES:

1. THE STORAGE PLAN SHOWN IN THIS PAGE IS TYPICAL ONLY, AND CAN BE APPLIED TO NUMEROUS LOTS AND VARIOUS MAGAZINES. ADAPTATIONS MAY BE MADE AS NUMBER AND SIZES OF LOTS TO BE STORED IN MAGAZINE REQUIRE.
2. GENERALLY, THE LARGEST LOT SHOULD BE STORED IN THE REAR OR ON ONE SIDE OF THE MAGAZINE. HOWEVER, THESE AREAS MAY BE USED TO STORE MORE THAN ONE LOT BY ERECTING STACKS SIMILAR TO THOSE SHOWN IN THE FRONTAL AREA. AN MHE AISLE WILL BE REQUIRED ON ONE SIDE OF THE MAGAZINE, AND EACH LOT MUST BE ACCESSIBLE FOR REMOVAL AND INSPECTION/INVENTORY IN ACCORDANCE WITH OTHER CRITERIA SPECIFIED IN THESE SPECIAL NOTES AND IN THE GENERAL NOTES ON PAGE 2.
3. A MIXED-LOT PALLET UNIT MAY HAVE TWO LOTS PER PALLET. HOWEVER, BOTH LOTS WITHIN THE PALLET UNIT MUST HAVE THE SAME NATIONAL STOCK NUMBER AND CONDITION CODE.
4. EACH LOT WITHIN THE MAGAZINE MUST BE ACCESSIBLE FOR MOVEMENT BY MHE. PALLET UNITS OF A SINGLE-LOT OR MIXED-LOT PALLET UNITS ARE CONSIDERED "ACCESSIBLE" IF NO MORE THAN 12 "LIFTS" OF ANOTHER LOT OR LOTS HAVE TO BE MADE TO GAIN ACCESS TO THE SINGLE-LOT OR MIXED-LOT PALLET. A "LIFT" MAY CONSIST OF ONE OR MORE PALLET UNITS, PROVIDING THE CAPACITY OF THE MHE PERMITS, AND SAFE HANDLING IS NOT JEOPARDIZED. THE ONLY EXCEPTION TO THE 12-LIFT RULE IS FOR USE WHEN STORING MULTIPLE LOTS IN RECTANGULAR MAGAZINES, IN WHICH CASE IT BECOMES A 24-LIFT RULE, WHERE PALLET UNITS MUST BE ACCESSIBLE WITHIN 24 LIFTS.

(CONTINUED AT RIGHT)

(SPECIAL NOTES CONTINUED)

5. FOR STORAGE OF MULTIPLE LOTS, THE DISTANCE FROM THE SIDEWALL WILL BE BASED ON THE OVERHEAD CLEARANCE REQUIRED FOR MHE.
6. WHEN TWO LOTS ARE STORED ADJACENT TO EACH OTHER, THEY SHOULD BE SEPARATED BY AT LEAST 1" TO PROVIDE CLEARANCE FOR REMOVAL OF EITHER LOT.
7. THE MHE AISLE MAY BE USED TO STORE ONE OR MORE STACKS OF ADDITIONAL LOTS OR ADDITIONAL UNITS THAT ARE FROM A LOT ADJACENT TO THE MHE AISLE. ADEQUATE SPACE FROM MHE OPERATION MUST BE MADE AVAILABLE FOR THE ADDITIONAL STORAGE. ALSO, COMPLIANCE WITH ALL MULTIPLE-LOT CRITERIA AS SET FORTH ON THIS PAGE MUST BE OBSERVED.

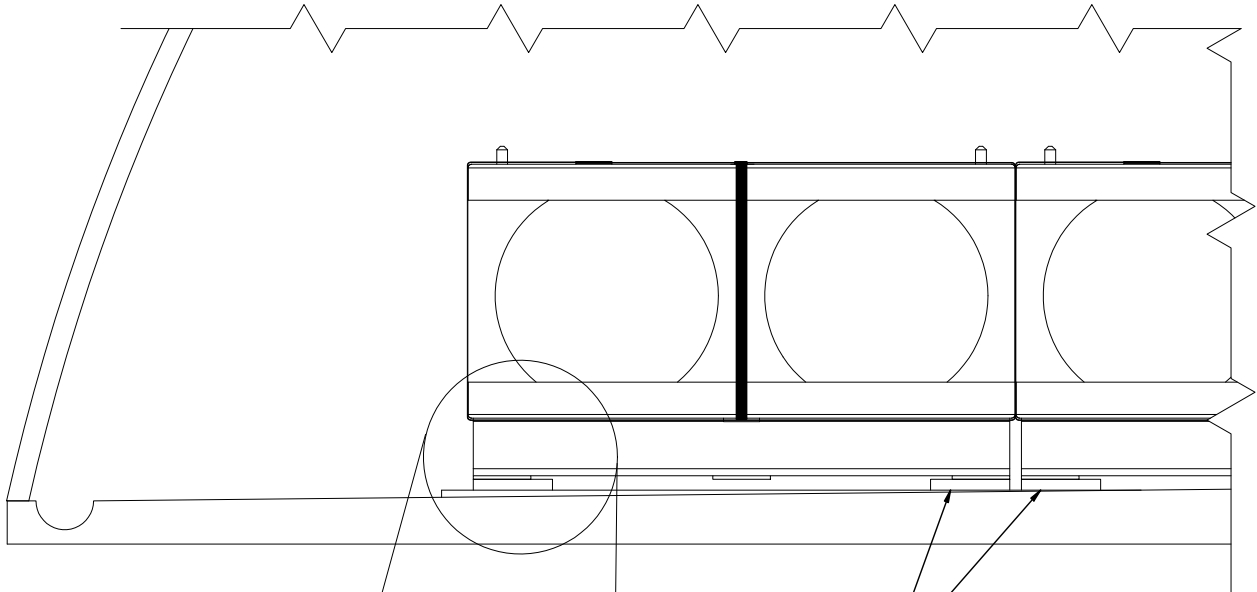

FLOOR DUNNAGE, 1" X 6" X 47"
 (2 REQD PER FIRST LAYER UNIT).
 SEE GENERAL NOTE "K"
 ON PAGE 2.

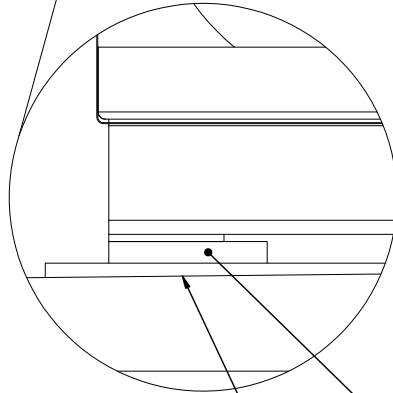

FLOOR DUNNAGE (REF)

SHIM (AS REQD TO PROVIDE A
 LEVEL BEARING SURFACE FOR
 THE FIRST LAYER CONTAINERS).
 POSITION UNDER CONTAINER
 SKIDS. SEE GENERAL NOTE "P"
 ON PAGE 2.

FLOOR DUNNAGE AND SHIM LOCATION DETAILS

