

# LOADING AND BRACING (TL & LTL) IN VAN TRAILERS\* OF HARPOON (RGM-84) MISSILES PACKED IN MK694 MOD 0 CONTAINERS

## INDEX

ITEM	PAGE(S)
GENERAL NOTES AND MATERIAL SPECIFICATIONS - - - - -	2
MK694 MOD 0 CONTAINER DETAIL - - - - -	3
7 UNIT LOAD IN A 53' -0" LONG BY 8' -2" WIDE VAN TRAILER - - - - -	4-5
6 UNIT LOAD IN A 45' -0" LONG BY 7' -8" WIDE VAN TRAILER - - - - -	6-7
6 UNIT LOAD IN A 40' -0" LONG BY 8' -2" WIDE VAN TRAILER - - - - -	8-9
TYPICAL LTL (2 UNIT LOAD) - - - - -	10-11
DETAILS - - - - -	12-14

DISTRIBUTION STATEMENT A:

APPROVED FOR PUBLIC  
RELEASE DISTRIBUTION IS  
UNLIMITED.

**\*CAUTION: THE PROCEDURES SHOWN HEREIN ARE ONLY APPLICABLE TO HIGHWAY  
MOVEMENTS, NOT TRAILER-ON-FLATCAR(TOFC) MOVEMENTS.**

## U.S. ARMY MATERIEL COMMAND DRAWING

<p>APPROVED, U.S. ARMY JOINT MUNITIONS COMMAND</p> <p><b>RUS.ALLEN.J</b> 1230354282</p> <p><small>Digitally signed by RUS.ALLEN.J.1230354282 DN: c=US, o=U.S. Government, ou=DoD, ou=PKI, ou=USA, cn=RUS.ALLEN.J.1230354282 Date: 2011.01.06 10:49:31 -06'00'</small></p>	<p><b>CAUTION: VERIFY PRIOR TO USE AT WWW.DAC.ARMY.MIL THAT THIS IS THE MOST CURRENT VERSION OF THIS DOCUMENT. THIS IS PAGE 1 OF 14.</b></p>																		
<p>APPROVED BY ORDER OF COMMANDING GENERAL, U.S. ARMY MATERIEL COMMAND</p> <p><b>CARNEY.GARY</b> <b>BURTON.10387</b> 08038</p> <p><small>Digitally signed by CARNEY.GARY.BURTON.1038708038 DN: c=US, o=U.S. Government, ou=DoD, ou=PKI, ou=USA, cn=CARNEY.GARY.BURTON.1038708038 Date: 2011.01.12 11:27:12 -06'00'</small></p> <p style="text-align: center;">U.S. ARMY DEFENSE AMMUNITION CENTER</p>	<p><b>DO NOT SCALE</b></p>	<p><b>NOVEMBER 2010</b></p>																	
	<table border="1" style="width: 100%; border-collapse: collapse;"> <tr> <td style="width: 15%;">ENGINEER OR TECHNICIAN</td> <td style="width: 15%;">BASIC REV.</td> <td colspan="2" style="text-align: center;">RICHARD GARSIDE</td> </tr> </table>	ENGINEER OR TECHNICIAN	BASIC REV.	RICHARD GARSIDE		<table border="1" style="width: 100%; border-collapse: collapse;"> <tr> <td style="width: 25%;">TRANSPORTATION ENGINEERING DIVISION</td> <td style="width: 25%;">FIEFFER.LAUR A.A.1230375727</td> <td style="width: 25%;"></td> <td style="width: 25%;"></td> </tr> <tr> <td style="width: 25%;">VALIDATION ENGINEERING DIVISION</td> <td style="width: 25%;">BARICKMAN PHILIP.W.12 30202202</td> <td style="width: 25%;">TESTED</td> <td style="width: 25%;"></td> </tr> <tr> <td style="width: 25%;">ENGINEERING DIRECTORATE</td> <td style="width: 25%;">BEAVER.JERRY W.1230949952</td> <td style="width: 25%;"></td> <td style="width: 25%;"></td> </tr> </table>			TRANSPORTATION ENGINEERING DIVISION	FIEFFER.LAUR A.A.1230375727			VALIDATION ENGINEERING DIVISION	BARICKMAN PHILIP.W.12 30202202	TESTED		ENGINEERING DIRECTORATE	BEAVER.JERRY W.1230949952	
ENGINEER OR TECHNICIAN	BASIC REV.	RICHARD GARSIDE																	
TRANSPORTATION ENGINEERING DIVISION	FIEFFER.LAUR A.A.1230375727																		
VALIDATION ENGINEERING DIVISION	BARICKMAN PHILIP.W.12 30202202	TESTED																	
ENGINEERING DIRECTORATE	BEAVER.JERRY W.1230949952																		
		<table border="1" style="width: 100%; border-collapse: collapse;"> <tr> <td style="width: 15%;">CLASS</td> <td style="width: 15%;">DIVISION</td> <td style="width: 15%;">DRAWING</td> <td style="width: 15%;">FILE</td> </tr> <tr> <td style="text-align: center;">19</td> <td style="text-align: center;">48</td> <td style="text-align: center;">8757</td> <td style="text-align: center;">SP11J115</td> </tr> </table>	CLASS	DIVISION	DRAWING	FILE	19	48	8757	SP11J115									
CLASS	DIVISION	DRAWING	FILE																
19	48	8757	SP11J115																

**GENERAL NOTES**

**(GENERAL NOTES CONTINUED)**

- A. THIS DOCUMENT HAS BEEN PREPARED AND ISSUED IN ACCORDANCE WITH AR 740-1 AND AUGMENTS TM 743-200-1 (CHAPTER 5).
- B. THE SPECIFIED OUTLOADING PROCEDURES ARE APPLICABLE TO LOADS OF HARPOON MISSILE (RGM-84) PACKED IN MK694 MOD 0 CONTAINER. SUBSEQUENT REFERENCE TO CONTAINER HEREIN MEANS THE CONTAINER WITH MISSILE ITEMS. SEE PAGE 3 AND NAVAL SEA SYSTEMS COMMAND DRAWING DL5167322 FOR DETAILS OF THE CONTAINER.
- C. THE OUTLOADING PROCEDURES DEPICTED WITHIN THIS DOCUMENT ARE APPLICABLE FOR SHIPMENTS IN CONVENTIONAL TYPE VAN TRAILERS AND APPLY TO TRAILERS HAVING WOOD, OR WOOD AND METAL, OR ALL METAL FLOORS. REGARDLESS OF THE DIMENSIONS OF THE VAN TRAILERS SHOWN, THE PROCEDURES ARE ALSO APPLICABLE FOR TRAILERS WHICH ARE 89" THRU 99" IN WIDTH AND FOR TRAILERS OF OTHER LENGTHS FROM THE SHORTEST TO THE LONGEST AVAILABLE (REF: 24' TO 53'), AND FOR STRAIGHT TRUCK VANS. THE SPECIFIED BRACING IS ADEQUATE FOR LOADS WEIGHING UP TO AND INCLUDING THE MAXIMUM WEIGHTS PERMITTED BY LAW.
- D. SELECTION OF A VEHICLE FOR THE TRANSPORT OF THE DESIGNATED ITEM IS THE RESPONSIBILITY OF THE ORIGINATING CARRIER AND THE SHIPPER. ONLY VEHICLES IN ACCORDANCE WITH THE REQUIREMENTS OF THE APPLICABLE REGULATORY DOCUMENTS WILL BE SELECTED FOR USE.
- E. GROSS WEIGHT AND AXLE DISTRIBUTION OF WEIGHT FOR A LOAD WILL BE THE RESPONSIBILITY OF THE CARRIER. THE CARRIER WILL ADVISE THE SHIPPER OF APPLICABLE LOADING REQUIREMENTS, AND THE SHIPPER WILL LOAD ACCORDINGLY. THE TOTAL WEIGHT OF THE LADING, OF THE DUNNAGE, OF THE TRACTOR, AND OF THE SEMITRAILER CARRYING THE LADING MUST NOT EXCEED THE MAXIMUM GROSS WEIGHT ALLOWED FOR THE STATE OR STATES THRU WHICH THE LOAD IS TO BE TRANSPORTED BY MOTOR CARRIER. LIKEWISE, THE GROSS WEIGHT ON A SINGLE OR TANDEM AXLE MUST NOT EXCEED THE MAXIMUM ALLOWABLE WEIGHT. IF THERE IS ANY DOUBT AS TO WHETHER THE TOTAL GROSS WEIGHT OR AXLE WEIGHT EXCEEDS THE MAXIMUM ALLOWED, WEIGHT SHOULD BE VERIFIED BY ACTUALLY WEIGHING THE LOADED VEHICLE.
- F. **NOTE:** A SHIPMENT WILL BE POSITIONED IN THE TRAILER CONSISTENT WITH STATE WEIGHT LAWS. THE NUMBER OF LADING UNITS MAY BE ADJUSTED TO FIT THE SIZE OF THE TRAILER TO BE LOADED OR THE QUANTITY TO BE SHIPPED. COMBINATIONS OF THE OUTLOADING PROCEDURES SPECIFIED MAY BE USED, HOWEVER, THE APPROVED METHODS SHOWN MUST BE FOLLOWED AS CLOSELY AS POSSIBLE FOR BLOCKING, BRACING, AND STAYING OF THE DESIGNATED ITEMS.
- G. THE "LOAD AS SHOWN" FOR MOST OF THE FULL LOADS DEPICTED HEREIN IS BASED ON AN APPROXIMATE LADING WEIGHT OF 35,000 POUNDS. THE SPECIFIED BLOCKING AND BRACING FOR THE FULL LOADS IS ADEQUATE FOR THE RETENTION OF LOADS UP TO 45,000 POUNDS IF IT IS DESIRED TO INCREASE THE LADING WEIGHT.
- H. OTHER TYPES OF LADING ITEMS MAY BE LOADED ON A TRAILER WHICH IS PARTIALLY LOADED WITH THE DESIGNATED ITEM, PROVIDING THE TOTAL LOAD IS COMPATIBLE, EXISTING DIRECTIVES ARE NOT VIOLATED, AND THE OTHER LADING ITEMS ARE BLOCKED AND BRACED TO EQUAL THE BLOCKING AND BRACING CRITERIA SPECIFIED HEREIN.
- J. SOME LOADS ARE SHOWN IN TRAILERS HAVING ROUNDED CORNERS AT THE FORWARD END. IF THE CONVENTIONAL VAN TRAILER BEING USED IS EQUIPPED WITH A SQUARE FRONT OR WITH AN INSTALLED BULKHEAD, OMIT THE FORWARD BLOCKING ASSEMBLY, AND POSITION THE CONTAINERS DIRECTLY AGAINST THE FORWARD PORTION OF THE TRAILER.
- K. WHEN STEEL STRAPPING IS SEALED AT AN END-OVER-END LAP JOINT, A MINIMUM OF ONE SEAL WITH TWO PAIR OF NOTCHES WILL BE USED TO SEAL THE JOINT WHEN A NOTCH-TYPE SEALER IS BEING USED. A MINIMUM OF TWO SEALS, BUTTED TOGETHER WITH TWO PAIR OF CRIMPS PER SEAL WILL BE USED TO SEAL THE JOINT WHEN A CRIMP-TYPE SEALER IS BEING USED. REFER TO THE "END-OVER-END LAP JOINT DETAILS" ON PAGE 3 FOR GUIDANCE.

- L. A STAGGERED NAILING PATTERN WILL BE USED WHEREVER POSSIBLE WHEN NAILS ARE DRIVEN INTO JOINTS OF DUNNAGE ASSEMBLIES. ALSO, A STAGGERED NAILING PATTERN WILL BE USED WHEN DUNNAGE IS NAILED TO THE FLOOR OF THE TRANSPORTING VEHICLE, OR WHEN LAMINATING DUNNAGE. THE NAILING PATTERN WILL BE ADJUSTED AS REQUIRED SO THAT A NAIL DOES NOT PENETRATE INTO OR NEAR A CRACK BETWEEN FLOOR BOARDS. ADDITIONALLY, THE NAILING PATTERN FOR AN UPPER PIECE OF LAMINATED DUNNAGE WILL BE ADJUSTED AS REQUIRED SO THAT A NAIL FOR THAT PIECE WILL NOT BE DRIVEN THROUGH THE PIECE ONTO OR RIGHT BESIDE A NAIL IN A LOWER PIECE.
- M. POWER DRIVEN STAPLES MAY BE USED AS ALTERNATIVE FASTENERS FOR NAILS WHEN CONSTRUCTING DUNNAGE ASSEMBLIES THAT ARE TO BE USED IN THE DELINEATED TRAILER LOADS SHOWN THROUGHOUT THIS DRAWING. THE STAPLES TO BE USED MUST BE EQUAL IN LENGTH TO THE SPECIFIED NAIL SIZE AND MUST BE SUBSTITUTED ON A ONE STAPLE FOR ONE NAIL BASIS. STAPLES WHICH ARE 2-1/2" OR LESS IN LENGTH SHOULD BE IN ACCORDANCE WITH ASTM F1667 AS NEARLY AS PRACTICABLE. STAPLES THAT ARE LONGER THAN 2-1/2" WILL BE A COMMERCIAL GRADE, OF A QUALITY EQUIVALENT TO THOSE MANUFACTURED BY SENCO PRODUCTS INCORPORATED. **NOTE:** STAPLES WILL NOT BE SUBSTITUTED FOR NAILS IN ANY LOAD RESTRAINING FLOOR DUNNAGE APPLICATION.
- N. THE UNBLOCKED SPACE ACROSS THE WIDTH OF A LOAD BAY IS NOT TO EXCEED 6". EXCESSIVE SLACK CAN BE ELIMINATED FROM A LOAD BY LAMINATING ADDITIONAL PIECES OF APPROPRIATE THICKNESS TO THE CRIB FILL ASSEMBLIES. NAIL EACH ADDITIONAL PIECE TO THE HORIZONTAL PIECE W/1 APPROPRIATELY SIZED NAIL EVERY 12". ADDITIONALLY, THE LENGTH OF THE STRUTS USED IN THESE ASSEMBLIES MAY BE ADJUSTED AS REQUIRED TO FACILITATE VARIANCE IN THE SIZE OF THE CONTAINER.
- O. **CAUTION:** WHEN POWER OR PNEUMATIC NAILERS ARE BEING USED IN THE APPLICATION OF NAILED FLOORLINE BLOCKING OR BRACING, PALLET UNITS BEING LOADED INTO THE CONVEYANCE MUST BE POSITIONED TO ALLOW A CLEAR PATH OF EXIT FOR THE OPERATOR AT ALL TIMES, SHOULD AN EMERGENCY EXIT BECOME NECESSARY.
- P. IF THE SPACE AT THE REAR OF THE LOAD, BETWEEN THE CONTAINERS AND THE REAR DOOR MEASURES 1-1/2" OR LESS REAR BLOCKING IS NOT REQUIRED. IF THE SPACE AT THE REAR OF THE LOAD IS GREATER THAN 1-1/2" BUT LESS THE 9". USE THE LAMINATED REAR BLOCKING AS DEPICTED ON PAGE 12. IF THE VOID AT THE REAR OF THE LOAD IS 9" OR GREATER, USE THE "REAR BLOCKING ASSEMBLY" AS SHOWN ON PAGE 13. **NOTE:** REAR BLOCKING ASSEMBLIES MAY BE REPLACED WITH NAILED HEADERS AT THE REAR OF THE LOAD, PROVIDED THE TRAILER IS CONFIGURED SUCH AS TO ALLOW NAILING IN THE AREA IN QUESTION. REFER TO THE LOAD ON PAGE 4 AND THE HEADER NAILING CHARTS ON PAGE 5 FOR GUIDANCE. **CAUTION:** THE NAILED HEADER METHOD IS REQUIRED WHEN LOADING VAN TRAILERS EQUIPPED WITH ROLL-UP TYPE DOORS.
- Q. PORTIONS OF THE TRAILERS, SUCH AS SIDEWALLS, ENDWALLS, AND ROOFS, HAVE NOT BEEN SHOWN IN THE LOAD VIEWS FOR CLARITY PURPOSES.
- R. THESE PROCEDURES CAN ALSO BE UTILIZED FOR THE SHIPMENT OF MK694 CONTAINERS WHEN THEY ARE LOADED WITH AN ITEM OTHER THAN THE SPECIFIED MISSILE, OR WHEN THEY ARE EMPTY.
- S. DUNNAGE LUMBER SPECIFIED IS OF NOMINAL SIZE. FOR EXAMPLE, 1" X 4" MATERIAL IS ACTUALLY 3/4" THICK BY 3-1/2" WIDE AND 2" X 6" MATERIAL IS ACTUALLY 1-1/2" THICK BY 5-1/2" WIDE.
- T. ANTI-CHAFING MATERIAL MAY BE INSTALLED AT POINTS OF CONTACT BETWEEN CONTAINER AND STEEL STRAPPING, IF DESIRED, TO PREVENT CHAFING DAMAGE TO CONTAINER PAINT AND MARKINGS.
- U. CONVERSION TO METRIC EQUIVALENTS: DIMENSIONS WITHIN THIS DOCUMENT ARE EXPRESSED IN INCHES, AND WEIGHTS ARE EXPRESSED IN POUNDS. WHEN NECESSARY, THE METRIC EQUIVALENTS MAY BE COMPUTED ON THE BASIS OF ONE INCH EQUALS 25.4MM, AND ONE POUND EQUALS 0.454 KG.

(CONTINUED AT RIGHT)

**MATERIAL SPECIFICATIONS**

- LUMBER** - - - - - : SEE TM 743-200-1 (DUNNAGE LUMBER) AND VOLUNTARY PRODUCT STANDARD PS 20.
- NAI LS** - - - - - : ASTM F1667; COMMON STEEL NAIL (NLCMS OR NLCMS).
- STRAPPING, STEEL** - - : ASTM D3953; FLAT STRAPPING, TYPE 1, HEAVY DUTY, FINISH A, B (GRADE 2), OR C.
- SEAL, STRAP** - - - - : ASTM D3953; CLASS H, FINISH A, B (GRADE 2), OR C, DOUBLE NOTCH TYPE, STYLE I, II, OR IV.
- ANTI -CHAFING MATERIAL** - - - - - : MI L-PRF-121 (OR EQUAL); NEUTRAL BARRIER MATERIAL.

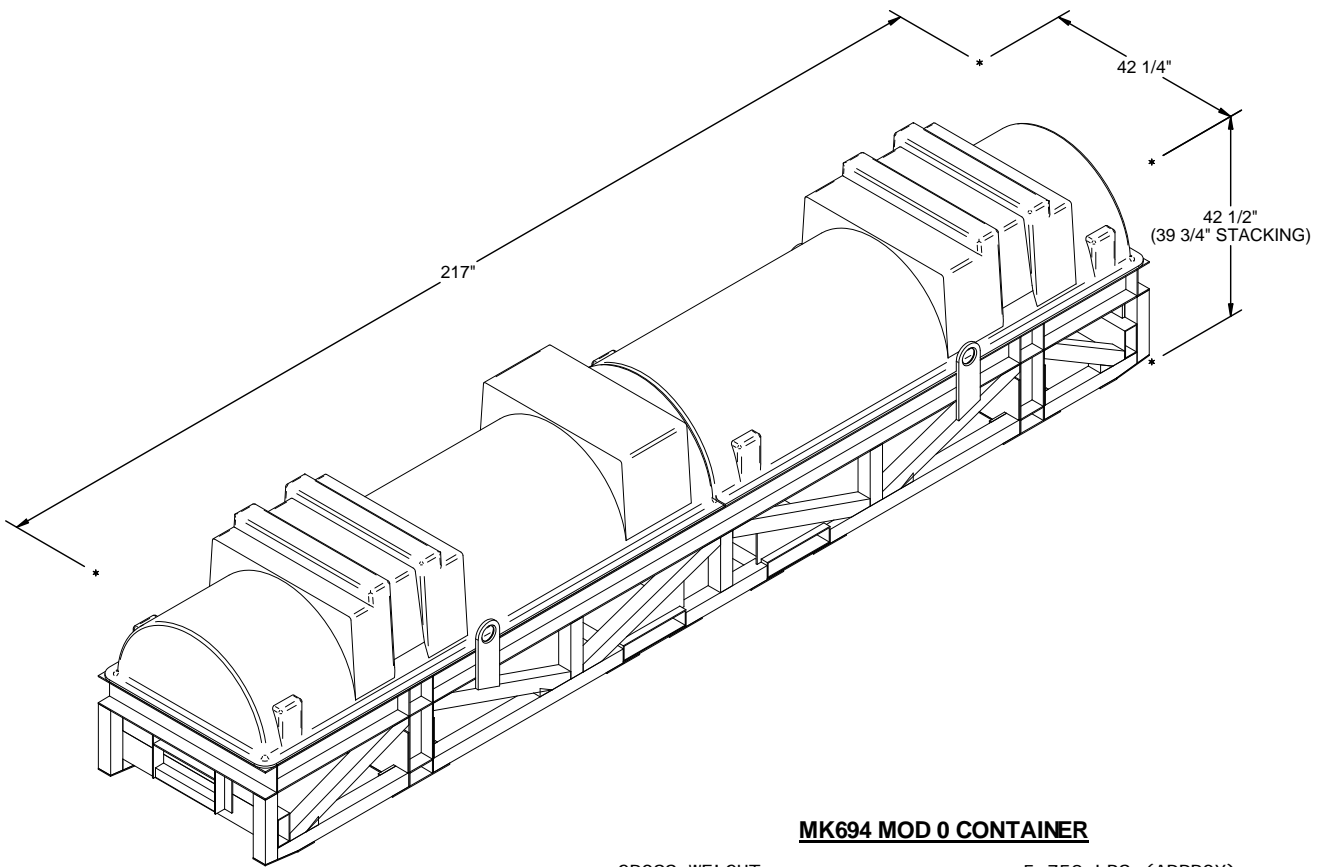

**MK694 MOD 0 CONTAINER**

GROSS WEIGHT - - - - - 5,758 LBS (APPROX)  
 CUBE - - - - - 219.0 CU FT (APPROX)



ONE SEAL WITH  
TWO PAIR OF  
NOTCHES.

**STRAP JOINT A**

METHOD OF SECURING A  
STRAP JOINT WHEN USING  
A NOTCH-TYPE SEALER.



TWO SEALS, BUTTED  
TOGETHER, WITH  
TWO PAIR OF CRIMPS  
EACH SEAL.

**STRAP JOINT B**

METHOD OF SECURING A  
STRAP JOINT WHEN USING  
A CRIMP-TYPE SEALER.

**END-OVER-END LAP JOINT DETAILS**

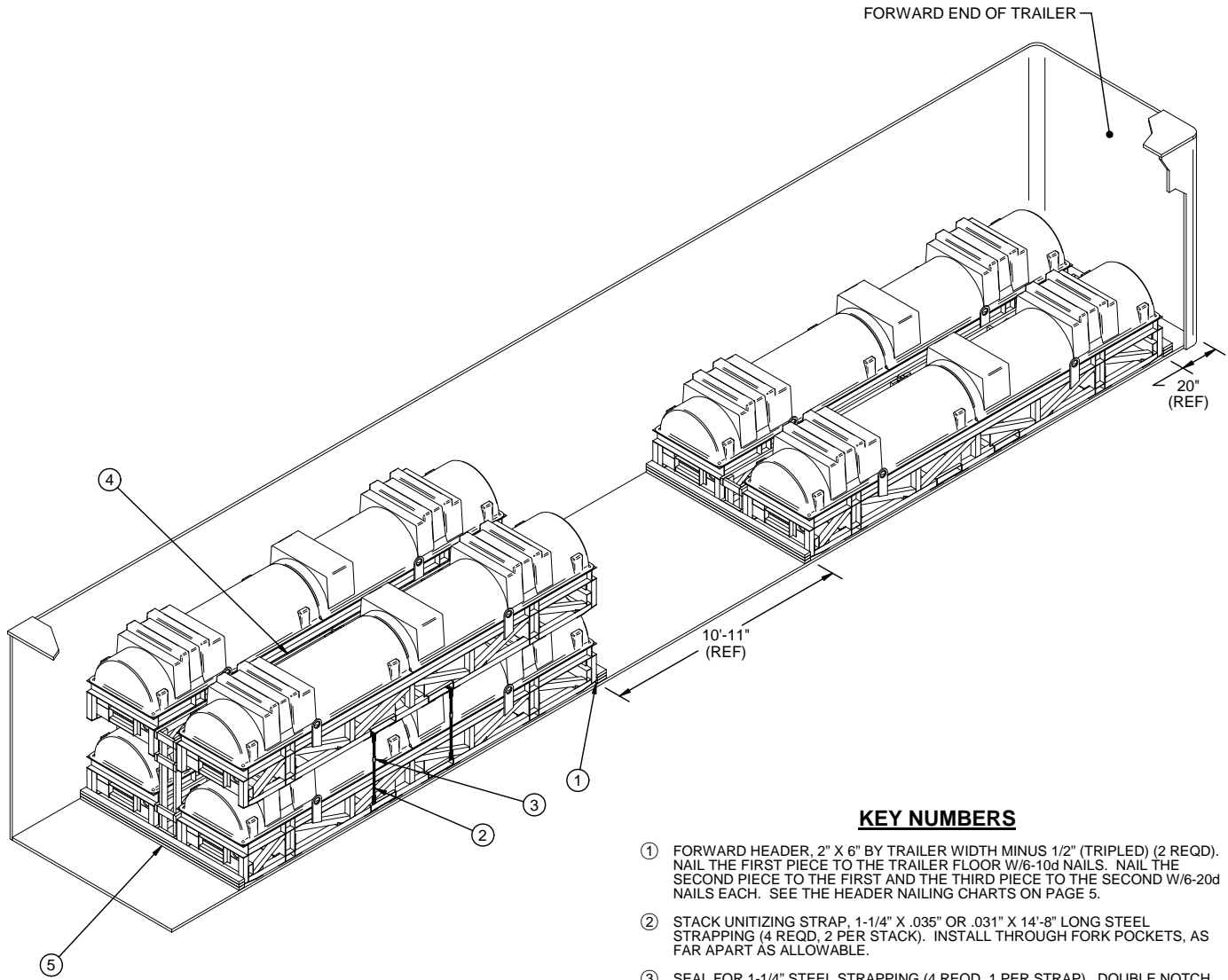

**ISOMETRIC VIEW**

**KEY NUMBERS**

- ① FORWARD HEADER, 2" X 6" BY TRAILER WIDTH MINUS 1/2" (TRIPLED) (2 REQD). NAIL THE FIRST PIECE TO THE TRAILER FLOOR W/6-10d NAILS. NAIL THE SECOND PIECE TO THE FIRST AND THE THIRD PIECE TO THE SECOND W/6-20d NAILS EACH. SEE THE HEADER NAILING CHARTS ON PAGE 5.
- ② STACK UNITIZING STRAP, 1-1/4" X .035" OR .031" X 14'-8" LONG STEEL STRAPPING (4 REQD, 2 PER STACK). INSTALL THROUGH FORK POCKETS, AS FAR APART AS ALLOWABLE.
- ③ SEAL FOR 1-1/4" STEEL STRAPPING (4 REQD, 1 PER STRAP). DOUBLE NOTCH EACH SEAL.
- ④ CRIB FILL ASSEMBLY A (4 REQD). SEE THE DETAIL ON PAGE 14.
- ⑤ REAR HEADER, 2" X 4" BY TRAILER WIDTH MINUS 1/2" (TRIPLED) (2 REQD). NAIL THE FIRST PIECE TO THE TRAILER FLOOR W/10-10d NAILS. NAIL THE SECOND PIECE TO THE FIRST AND THE THIRD PIECE TO THE SECOND W/10-10d NAILS EACH. SEE THE HEADER NAILING CHARTS ON PAGE 5.

**BILL OF MATERIAL**

LUMBER	LINEAR FEET	BOARD FEET
2" X 4"	343	229
2" X 6"	49	49
NAI LS	NO. REQD	POUNDS
10d (3")	312	4 3/4
20d (4")	24	1
STEEL STRAPPING, 1-1/4" - 59' REQD - - 8 1/2 LBS		
SEAL FOR 1-1/4" STRAPPING - 4 REQD - - - 1/4 LBS		

**LOAD AS SHOWN**

ITEM	QUANTI TY	WEIGHT (APPROX)
MK694	6	34,548 LBS
DUNNAGE		569 LBS
<b>TOTAL WEIGHT</b>		<b>35,117 LBS</b>

FORWARD HEADER NAILING CHART <sup>•</sup>	
#NAILS	MAX. LOAD WEIGHT (LBS)
3	15,000
4	20,000
5	25,000
6	30,000
7	35,000
8	40,000
9	45,000

- HEADERS AT THE FRONT END OF A LOAD OR AT THE FRONT END OF A DIVIDED LOAD WILL BE DOUBLED 2" X 6" MATERIAL. THE NUMBER OF NAILS INDICATED ABOVE REFERS TO THE NUMBER OF NAILS USED IN EACH LAMINATION OF A HEADER, FOR EXAMPLE 8 NAILS MEANS THE FIRST BOARD IS NAILED TO THE TRAILER FLOOR W/8-10d NAILS, AND THE SECOND BOARD IS LAMINATED TO THE FIRST W/8-20d NAILS, FOR A TOTAL OF 8-10d AND 8-20d NAILS PER HEADER. A MINIMUM OF 6 PAIRS OF NAILS WILL BE USED FOR TRAILER WIDTH HEADERS.

REAR HEADER NAILING CHART <sup>*</sup>	
#NAILS	MAX. LOAD WEIGHT (LBS)
6	15,000
7	17,500
8	20,000
9	22,500
10	25,000
11	27,500
12	30,000
13	32,500
14	35,000
15	37,500
16	40,000
17	42,500
18	45,000

- \* HEADERS AT THE REAR OF A FULL LOAD OR AT THE REAR END OF A DIVIDED LOAD WILL BE DOUBLED 2" X 4" MATERIAL. THE NUMBER OF NAILS INDICATED ABOVE REFERS TO THE NUMBER OF NAILS USED IN EACH LAMINATION OF A HEADER, FOR EXAMPLE 8 NAILS MEANS THE FIRST BOARD IS NAILED TO THE TRAILER FLOOR W/8-10d NAILS, AND THE SECOND BOARD IS LAMINATED TO THE FIRST W/8-10d NAILS, FOR A TOTAL OF 16-10d NAILS. A MINIMUM OF 6 PAIRS OF NAILS WILL BE USED FOR TRAILER WIDTH HEADERS. **NOTE:** REAR HEADERS MAY BE HANDLED IN THE SAME MANNER AS FORWARD HEADERS, USING 2" X 6" MATERIAL WITH 10d AND 20d NAILS, IF DESIRED.

**SPECIAL NOTES:**

1. A 53'-0" LONG BY 8'-2" WIDE (INSIDE DIMENSION) VAN TRAILER WITH NAILABLE FLOOR IS SHOWN. TRAILERS OF OTHER DIMENSIONS CAN BE USED.
2. A TRAILER EQUIPPED WITH ROUNDED FRONT CORNERS IS SHOWN. IF THE TRAILER TO BE LOADED HAS A SQUARE FRONT, THE FORWARD HEADER MAY BE OMITTED AND THE CONTAINERS POSITIONED DIRECTLY AGAINST THE TRAILER FRONT WALL.
3. THE NAILED HEADERS MAY BE REPLACED WITH A FORWARD BLOCKING ASSEMBLY, REAR BLOCKING ASSEMBLY AND CENTER BLOCKING ASSEMBLY. SEE DETAILS ON PAGES 12 AND 13.
4. THE DEPICTED LOAD CAN BE ADJUSTED TO SUIT THE QUANTITY TO BE SHIPPED, OR TO SUIT THE WEIGHT OF THE UNIT BEING LOADED.

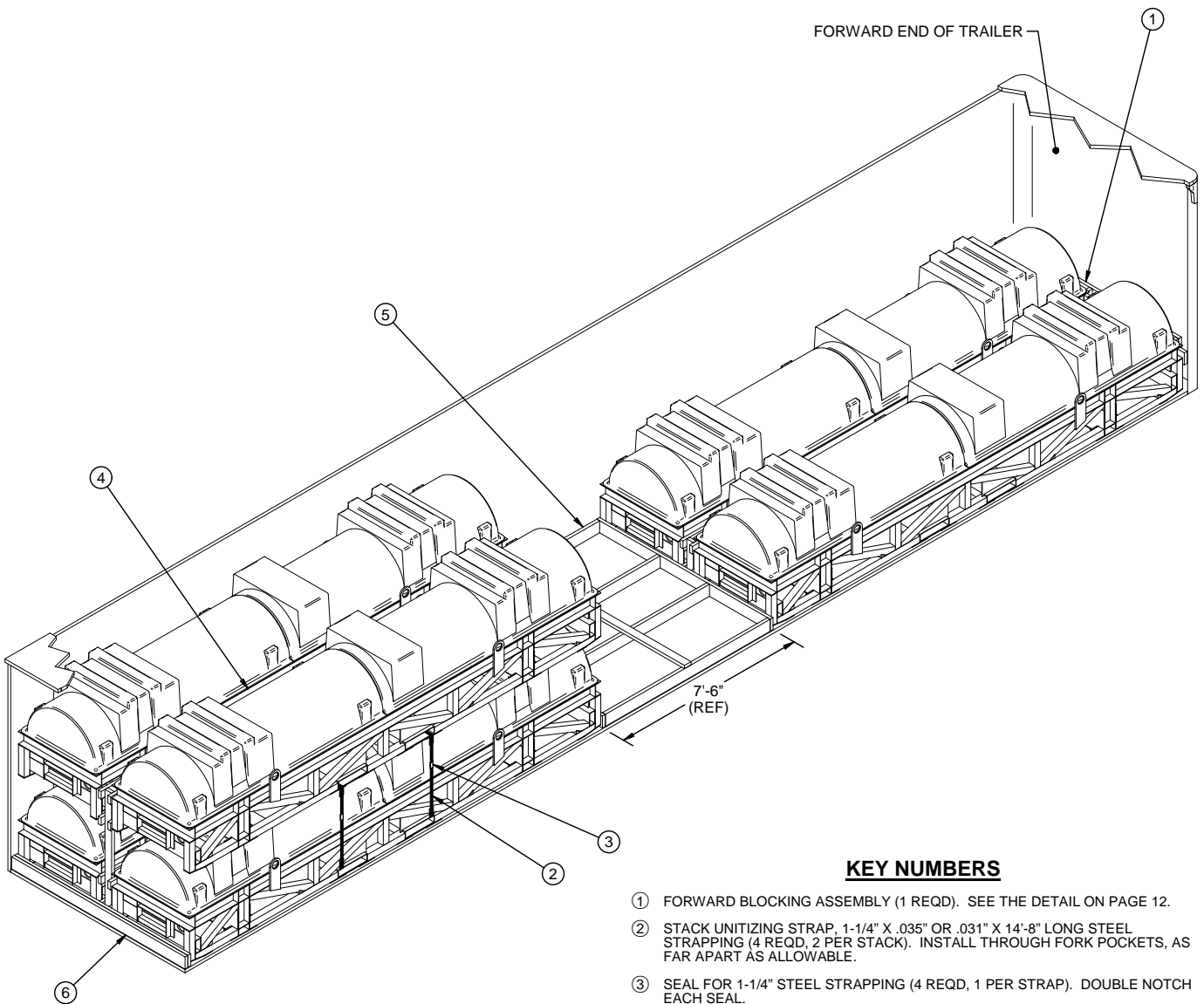

**ISOMETRIC VIEW**

**KEY NUMBERS**

- ① FORWARD BLOCKING ASSEMBLY (1 REQD). SEE THE DETAIL ON PAGE 12.
- ② STACK UNITIZING STRAP, 1-1/4" X .035" OR .031" X 14'-8" LONG STEEL STRAPPING (4 REQD, 2 PER STACK). INSTALL THROUGH FORK POCKETS, AS FAR APART AS ALLOWABLE.
- ③ SEAL FOR 1-1/4" STEEL STRAPPING (4 REQD, 1 PER STRAP). DOUBLE NOTCH EACH SEAL.
- ④ CRIB FILL ASSEMBLY B (4 REQD). SEE THE DETAIL ON PAGE 14.
- ⑤ CENTER BLOCKING ASSEMBLY (1 REQD), SEE THE DETAIL ON PAGE 13.
- ⑥ REAR BLOCKING ASSEMBLY A (1 REQD). SEE THE DETAIL ON PAGE 12.

**BILL OF MATERIAL**

LUMBER	LINEAR FEET	BOARD FEET
2" X 4"	264	176
2" X 6"	73	73
NAILS	NO. REQD	POUNDS
10d (3")	218	3 1/2
STEEL STRAPPING, 1-1/4" - 59' REQD - -		8 1/2 LBS
SEAL FOR 1-1/4" STRAPPING - 4 REQD - -		1/4 LBS

**LOAD AS SHOWN**

ITEM	QUANTITY	WEIGHT (APPROX)
MK694 - - - - -	6 - - - - -	34,548 LBS
DUNNAGE - - - - -	- - - - -	511 LBS
<b>TOTAL WEIGHT - - - - -</b>		<b>35,059 LBS</b>

**SPECIAL NOTES:**

1. A 45'-0" LONG BY 7'-8" WIDE (INSIDE DIMENSION) VAN TRAILER IS SHOWN. TRAILERS OF OTHER DIMENSIONS CAN BE USED.
2. A TRAILER EQUIPPED WITH ROUNDED FRONT CORNERS IS SHOWN. IF THE TRAILER TO BE LOADED HAS A SQUARE FRONT, OMIT THE FORWARD BLOCKING ASSEMBLY AND POSITION THE CONTAINERS DIRECTLY AGAINST THE TRAILER FRONT WALL.
3. THE FORWARD BLOCKING ASSEMBLY, REAR BLOCKING ASSEMBLY AND CENTER BLOCKING ASSEMBLY MAY BE REPLACED WITH NAILED HEADERS, PROVIDED THE TRAILER IS CONFIGURED SUCH AS TO ALLOW NAILING IN THE AREA IN QUESTION. REFER TO THE LOAD ON PAGE 4 FOR GUIDANCE.
4. IF THE SPACE AT THE REAR OF THE LOAD BETWEEN THE CONTAINERS AND THE REAR DOORS IS GREATER THAN 1-1/2" BUT LESS THAN 9", USE THE "REAR BLOCKING ASSEMBLY A" AS SHOWN. IF THE SPACE AT THE REAR OF THE LOAD IS 9" OR GREATER, USE THE "REAR BLOCKING ASSEMBLY B" AS SHOWN ON PAGE 13. IF THE SPACE AT THE REAR OF THE LOAD IS 1-1/2" OR LESS, REAR BLOCKING IS NOT REQUIRED.
5. THE DEPICTED LOAD CAN BE ADJUSTED TO SUIT THE QUANTITY TO BE SHIPPED, OR TO SUIT THE WEIGHT OF THE UNIT BEING LOADED.

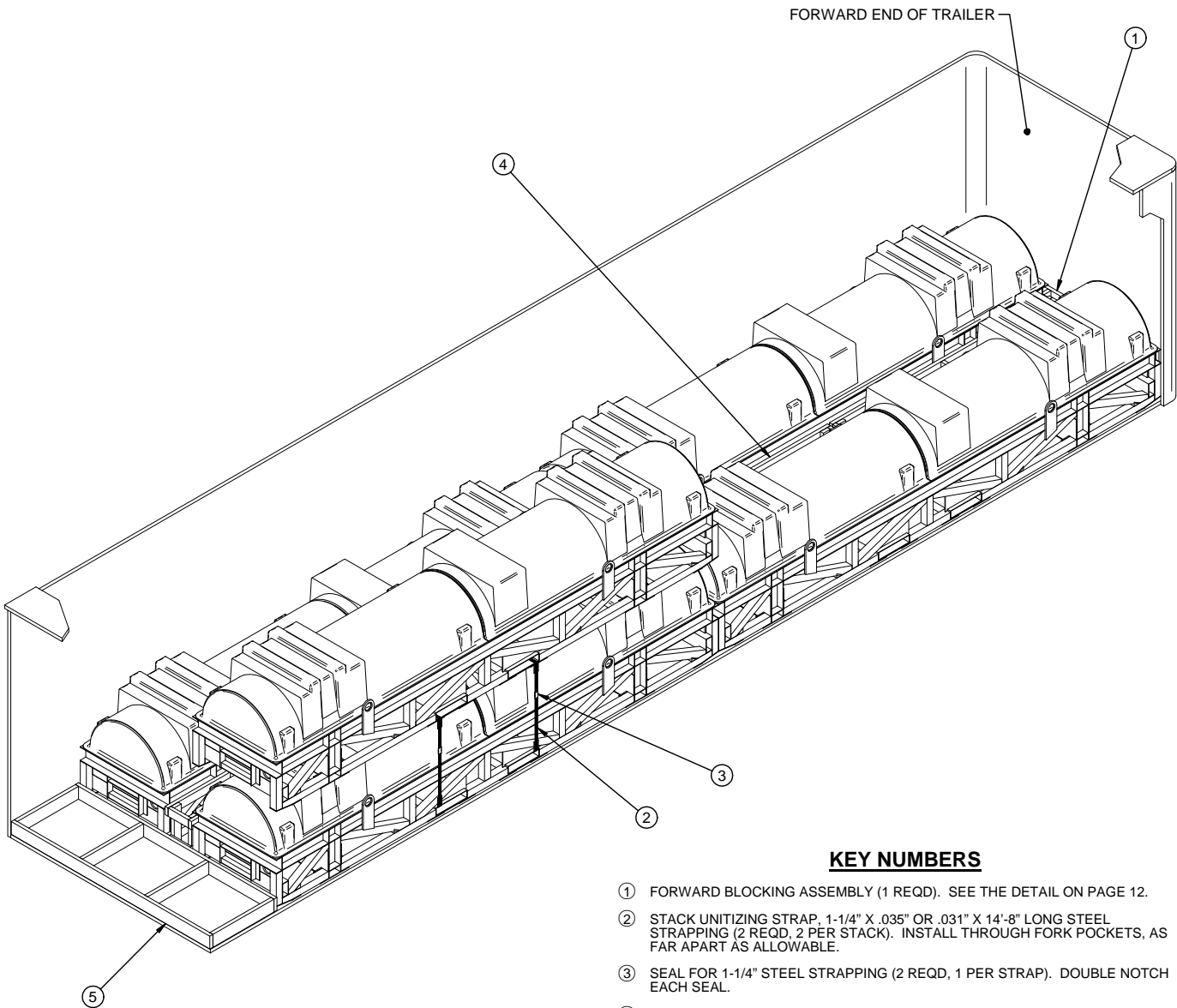

**ISOMETRIC VIEW**

**KEY NUMBERS**

- ① FORWARD BLOCKING ASSEMBLY (1 REQD). SEE THE DETAIL ON PAGE 12.
- ② STACK UNITIZING STRAP, 1-1/4" X .035" OR .031" X 14'-8" LONG STEEL STRAPPING (2 REQD, 2 PER STACK). INSTALL THROUGH FORK POCKETS, AS FAR APART AS ALLOWABLE.
- ③ SEAL FOR 1-1/4" STEEL STRAPPING (2 REQD, 1 PER STRAP). DOUBLE NOTCH EACH SEAL.
- ④ CRIB FILL ASSEMBLY A (4 REQD). SEE THE DETAIL ON PAGE 14.
- ⑤ REAR BLOCKING ASSEMBLY B (1 REQD). SEE THE DETAIL ON PAGE 13.

**BILL OF MATERIAL**

LUMBER	LINEAR FEET	BOARD FEET
2" X 4"	191	127
2" X 6"	41	41
NAI LS	NO. REQD	POUNDS
10d (3")	208	3 1/4
STEEL STRAPPING, 1-1/4" - 29' REQD		4 1/4 LBS
SEAL FOR 1-1/4" STRAPPING - 2 REQD		1/4 LBS

**LOAD AS SHOWN**

ITEM	QUANTITY	WEIGHT (APPROX)
MK694	5	28,790 LBS
DUNNAGE		344 LBS
<b>TOTAL WEIGHT</b>		<b>29,134 LBS</b>



**SPECIAL NOTES:**

1. A 40'-0" LONG BY 8'-2" WIDE (INSIDE DIMENSION) VAN TRAILER IS SHOWN. TRAILERS OF OTHER DIMENSIONS CAN BE USED.
2. A TRAILER EQUIPPED WITH ROUNDED FRONT CORNERS IS SHOWN. IF THE TRAILER TO BE LOADED HAS A SQUARE FRONT, OMIT THE FORWARD BLOCKING ASSEMBLY AND POSITION THE CONTAINERS DIRECTLY AGAINST THE TRAILER FRONT WALL.
3. THE FORWARD BLOCKING ASSEMBLY AND REAR BLOCKING ASSEMBLY MAY BE REPLACED WITH NAILED HEADERS, PROVIDED THE TRAILER IS CONFIGURED SUCH AS TO ALLOW NAILING IN THE AREA IN QUESTION. REFER TO THE LOAD ON PAGE 4 FOR GUIDANCE.
4. IF THE SPACE AT THE REAR OF THE LOAD BETWEEN THE CONTAINERS AND THE REAR DOORS IS 9" OR GREATER, USE THE "REAR BLOCKING ASSEMBLY B" AS SHOWN. IF THE SPACE AT THE REAR OF THE LOAD IS GREATER THAN 1-1/2" BUT LESS THAN 9", USE THE "REAR BLOCKING ASSEMBLY A" AS SHOWN ON PAGE 12. IF THE SPACE AT THE REAR OF THE LOAD IS 1-1/2" OR LESS, REAR BLOCKING IS NOT REQUIRED.
5. THE DEPICTED LOAD CAN BE ADJUSTED TO SUIT THE QUANTITY TO BE SHIPPED, OR TO SUIT THE WEIGHT OF THE UNIT BEING LOADED.

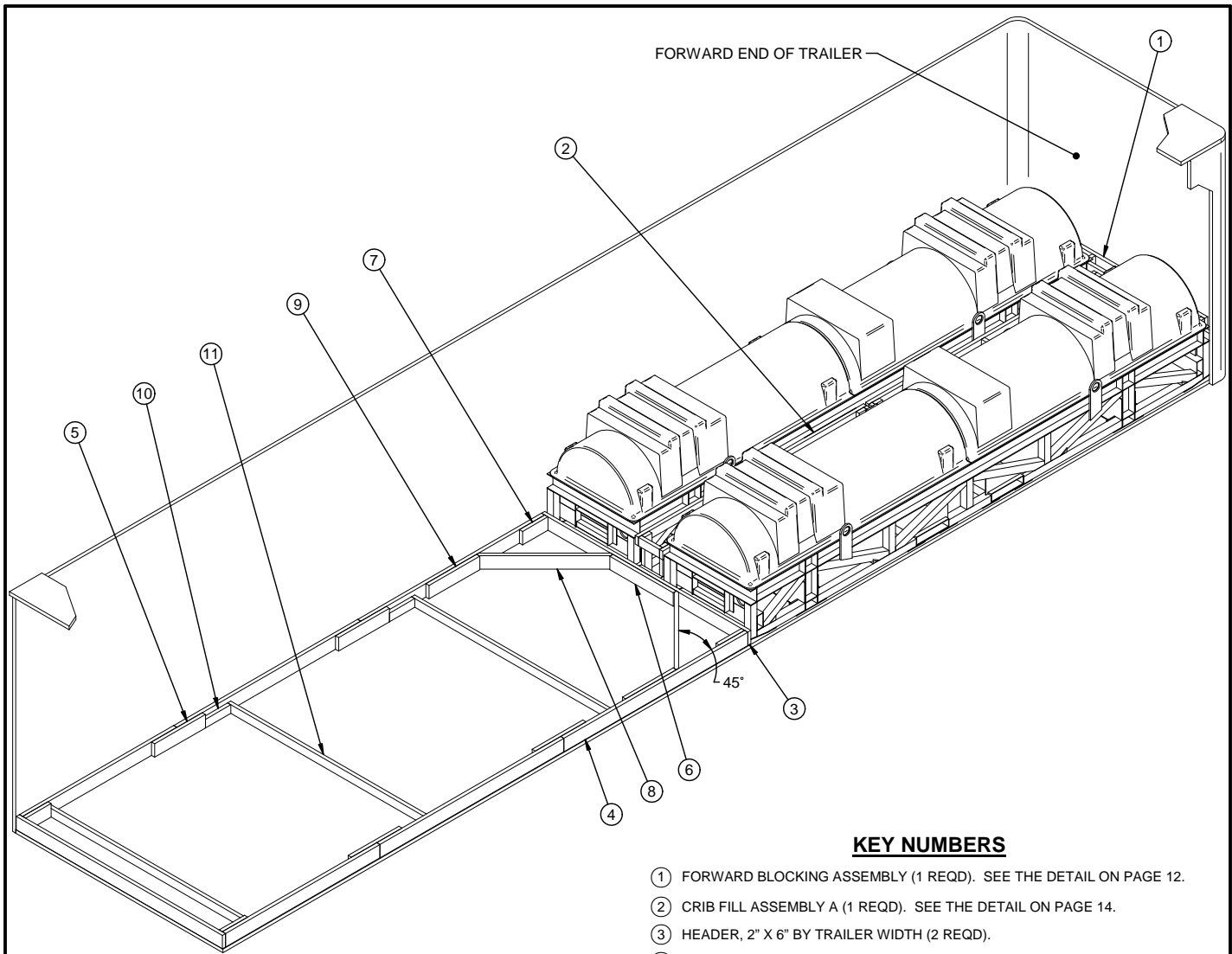

### ISOMETRIC VIEW

#### SPECIAL NOTES:

1. A 2 UNIT LOAD IS SHOWN IN AN 8'-2" WIDE (INSIDE DIMENSION) VAN TRAILER. TRAILERS OF OTHER WIDTHS CAN BE USED.
2. A TRAILER EQUIPPED WITH ROUNDED FRONT CORNERS IS SHOWN. IF THE TRAILER TO BE LOADED HAS A SQUARE FRONT, OMIT THE FORWARD BLOCKING ASSEMBLY AND POSITION THE CONTAINERS DIRECTLY AGAINST THE TRAILER FRONT WALL.
3. DEPENDING ON THE NUMBER OF UNITS BEING LOADED, EACH OF THE SIDE STRUTS MAY NEED TO BE FORMED FROM MORE THAN ONE PIECE OF MATERIAL. IF SUCH IS THE CASE, THE SIDE STRUTS MUST BE SPLICED. SPLICING CAN BE ACCOMPLISHED BY CENTERING A 2" X 6" X 24" PIECE ON THE JOINT OF THE SIDE STRUTS AND NAILING IT TO THE SIDE STRUTS W/4-10d NAILS AT EACH END. IF DESIRED, THE STRUT BRACE PIECE(S) MAY BE NAILED TO THE SPLICE PIECES IN LIEU OF USING ADDITIONAL STRUT BRACE CLEATS.
4. ALL LTL LOADS, REGARDLESS OF THEIR SIZE, REQUIRE ONE STRUT BRACE POSITIONED AT THE REAR OF THE TRAILER AND NAILED TO THE POCKET CLEAT. IF THE SIDE STRUTS ARE LONGER THAN 7'-0", AN ADDITIONAL STRUT BRACE AND TWO STRUT BRACE CLEATS MUST BE APPLIED FOR EVERY 7'-0" OF SIDE STRUT LENGTH.
5. THE "K-BRACE" BLOCKING IS ADEQUATE FOR RETAINING A MAXIMUM LTL LOAD OF 20,000 POUNDS.
6. TRAILERS EQUIPPED WITH ROLL-UP TYPE DOORS MAY BE USED; HOWEVER, THE NAILED-HEADER METHOD OF REAR BLOCKING MUST BE INSTALLED IN LIEU OF THE "K-BRACE" TYPE BLOCKING. REFER TO THE LOAD ON PAGE 4 FOR GUIDANCE. NOTE THAT THE NAILED-HEADER METHOD OF REAR BLOCKING MAY ALSO BE USED IN TRAILERS EQUIPPED WITH HINGED DOORS AND NAILABLE FLOORS, AND MAY BE USED IN LIEU OF THE "K-BRACE" PIECES WHICH APPLY TO TRAILERS HAVING NON-NAILABLE FLOORS.

#### KEY NUMBERS

- ① FORWARD BLOCKING ASSEMBLY (1 REQD). SEE THE DETAIL ON PAGE 12.
- ② CRIB FILL ASSEMBLY A (1 REQD). SEE THE DETAIL ON PAGE 14.
- ③ HEADER, 2" X 6" BY TRAILER WIDTH (2 REQD).
- ④ SIDE STRUT, 2" X 6" BY CUT TO FIT BETWEEN THE FORWARD AND REAR HEADERS (AS REQD). SEE SPECIAL NOTE 3 AT LEFT.
- ⑤ SPLICE PIECE, 2" X 6" X 24" (AS REQD). CENTER ON THE JOINT OF THE SIDE STRUTS AND NAIL W/4-10d NAILS AT EACH END. SEE SPECIAL NOTE 3 AT LEFT.
- ⑥ CENTER CLEAT, 2" X 6" X 30" (1 REQD). NAIL TO THE FORWARD HEADER W/6-10d NAILS.
- ⑦ POCKET CLEAT, 2" X 6" X 12" (4 REQD). NAIL TO A SIDE STRUT W/5-10d NAILS AND TOENAIL TO THE HEADER W/3-12d NAILS.
- ⑧ DIAGONAL BRACE, 2" X 6" BY CUT TO FIT (2 REQD). DOUBLE BEVEL EACH END WITH 45° CUTS. INSTALL AS SHOWN AND TOENAIL TO THE HEADER AND THE SIDE STRUT W/2-16d NAILS AT EACH END.
- ⑨ BACK-UP CLEAT, 2" X 6" X 24" (2 REQD). POSITION ON THE SIDE STRUT TO HOLD THE DIAGONAL BRACE IN PLACE AND NAIL TO THE SIDE STRUT W/8-10d NAILS.
- ⑩ STRUT BRACE CLEAT, 2" X 4" X 12" (AS REQD). NAIL TO THE SIDE STRUT W/3-10d NAILS. SEE SPECIAL NOTE 4 AT LEFT.
- ⑪ STRUT BRACE, 2" X 4" BY TRAILER WIDTH MINUS 3" (CUT TO FIT) (MINIMUM OF ONE REQD). NAIL TO THE POCKET CLEATS AND/OR STRUT BRACE CLEATS W/2-12d NAILS AT EACH END. SEE SPECIAL NOTE 4 AT LEFT.

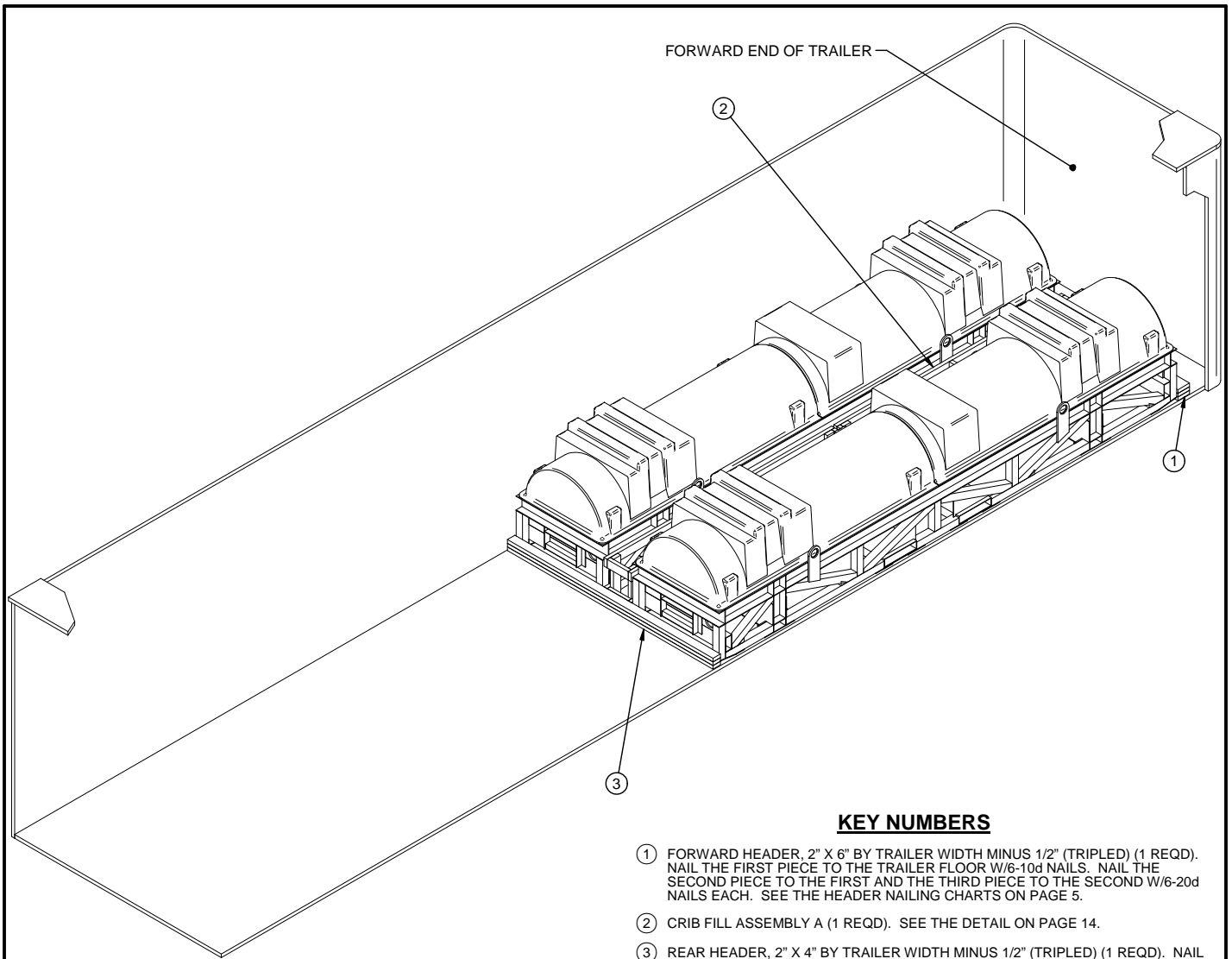

**ISOMETRIC VIEW**

**KEY NUMBERS**

- ① FORWARD HEADER, 2" X 6" BY TRAILER WIDTH MINUS 1/2" (TRIPLED) (1 REQD). NAIL THE FIRST PIECE TO THE TRAILER FLOOR W/6-10d NAILS. NAIL THE SECOND PIECE TO THE FIRST AND THE THIRD PIECE TO THE SECOND W/6-20d NAILS EACH. SEE THE HEADER NAILING CHARTS ON PAGE 5.
- ② CRIB FILL ASSEMBLY A (1 REQD). SEE THE DETAIL ON PAGE 14.
- ③ REAR HEADER, 2" X 4" BY TRAILER WIDTH MINUS 1/2" (TRIPLED) (1 REQD). NAIL THE FIRST PIECE TO THE TRAILER FLOOR W/6-10d NAILS. NAIL EACH ADDITIONAL PIECE IN A LIKE MANNER. SEE THE HEADER NAILING CHARTS ON PAGE 5.

**SPECIAL NOTES:**

- 1. A 2 UNIT LOAD IS SHOWN IN AN 8'-2" WIDE (INSIDE DIMENSION) VAN TRAILER. TRAILERS OF OTHER WIDTHS CAN BE USED.
- 2. A TRAILER EQUIPPED WITH ROUNDED FRONT CORNERS IS SHOWN. IF THE TRAILER TO BE LOADED HAS A SQUARE FRONT, THE FORWARD HEADER MAY BE OMITTED AND THE CONTAINERS POSITIONED DIRECTLY AGAINST THE TRAILER FRONT WALL.

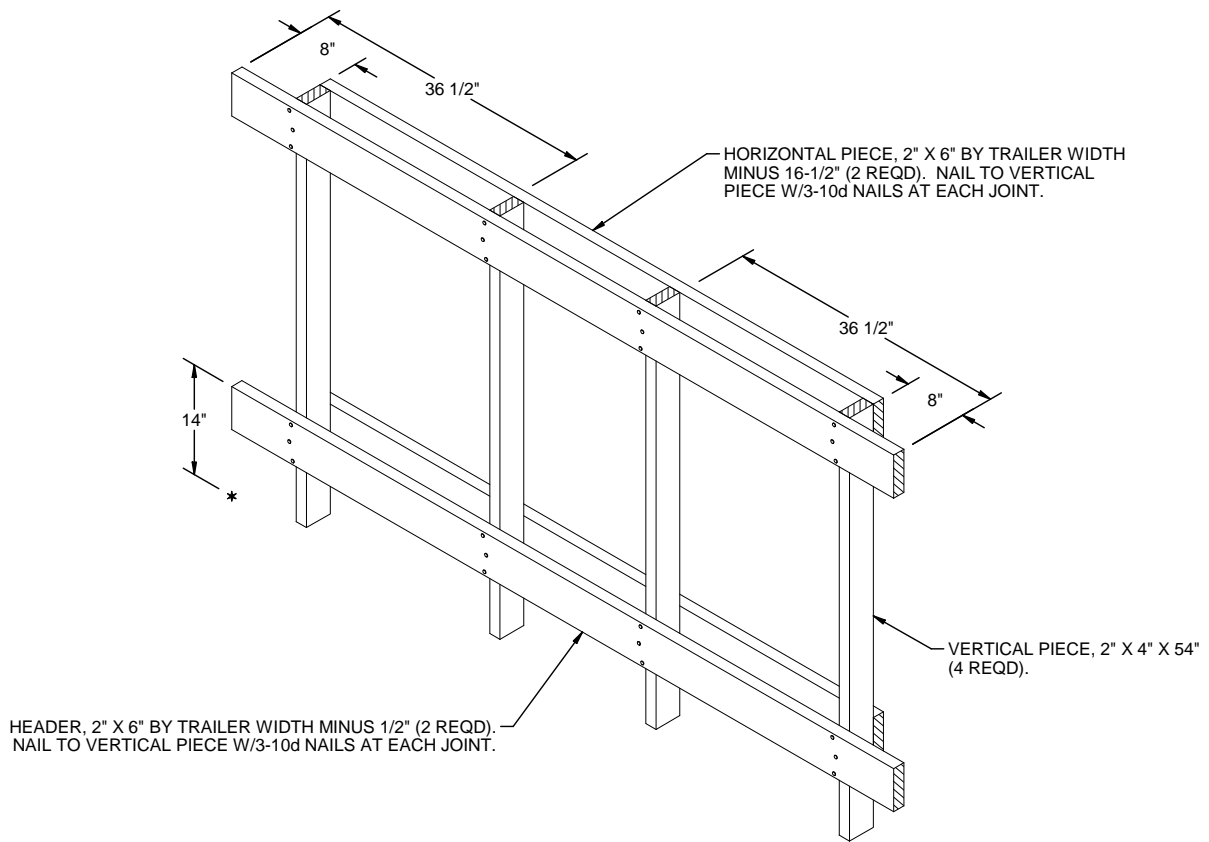

**FORWARD BLOCKING ASSEMBLY**

**NOTE:** FOR ONE HIGH LOADS, ELIMINATE THE TOP HEADER AND TOP HORIZONTAL PIECE, AND SHORTEN VERTICAL PIECES TO 14".

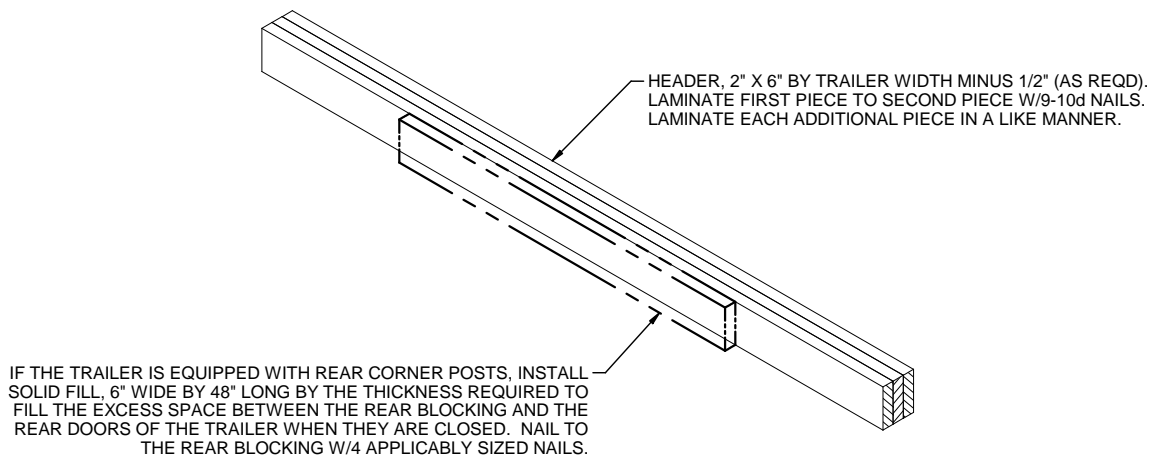

**REAR BLOCKING ASSEMBLY A**

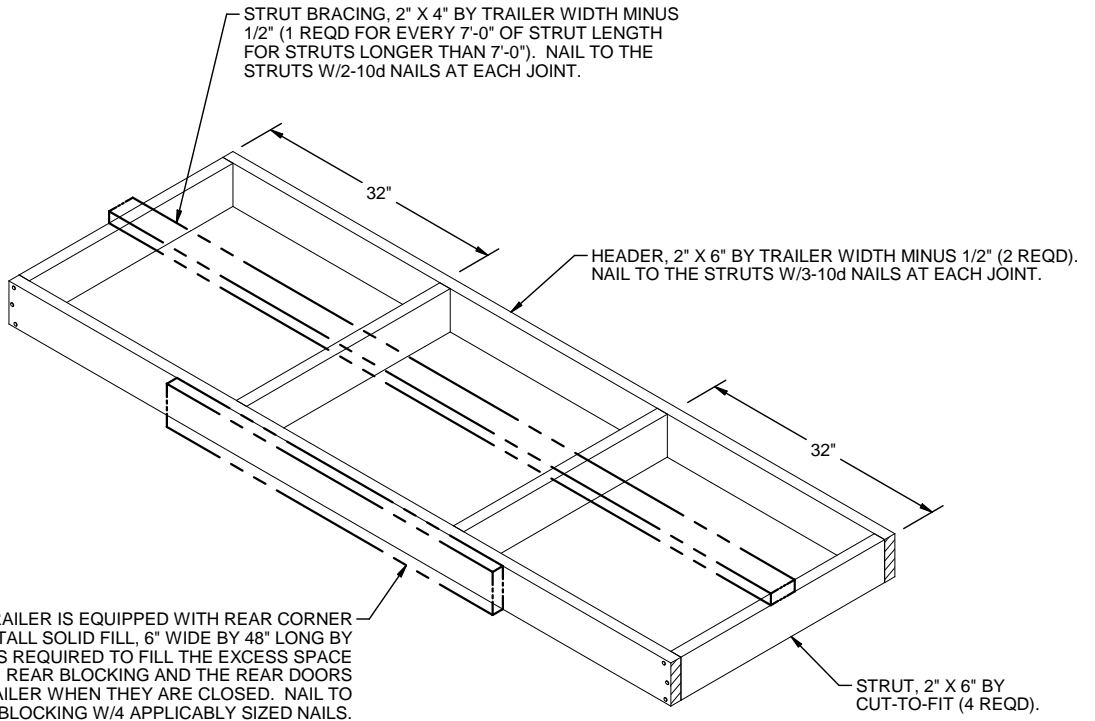

**REAR BLOCKING ASSEMBLY B**

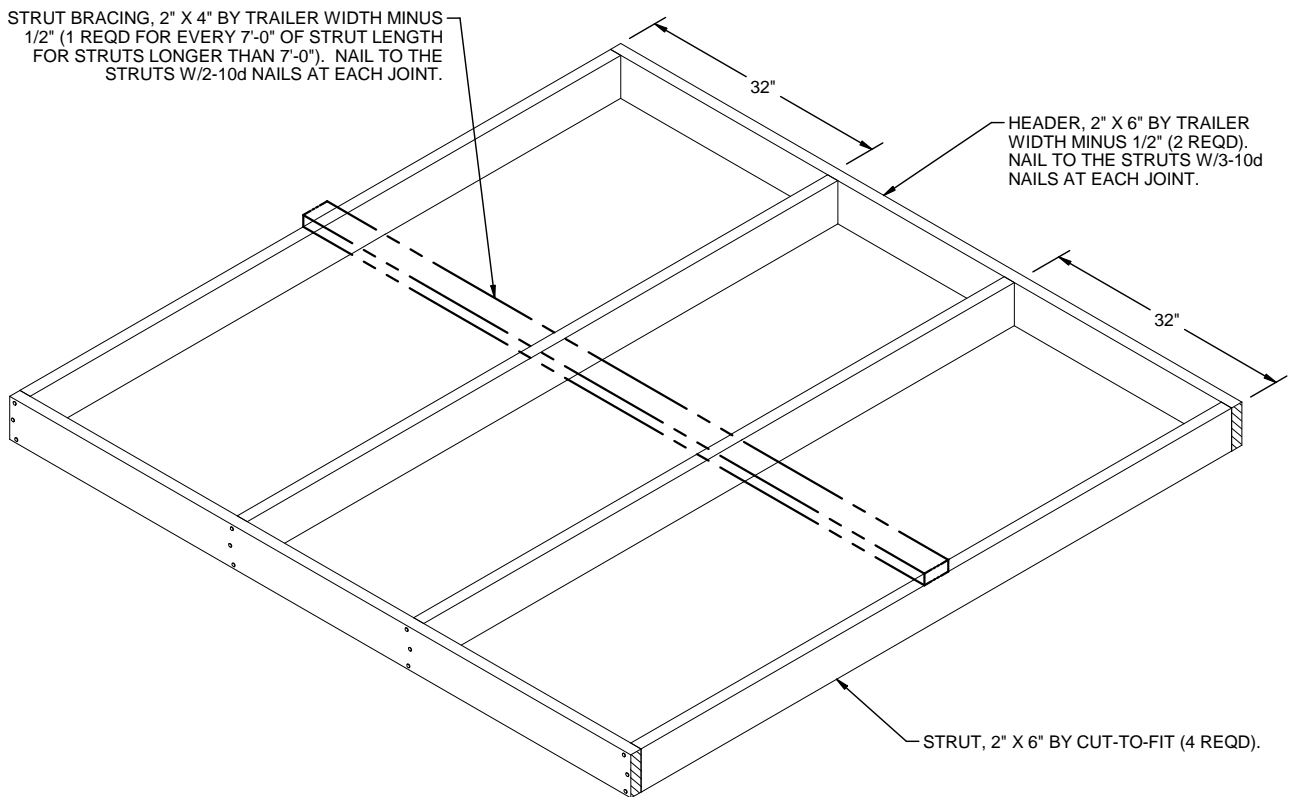

**CENTER BLOCKING ASSEMBLY**

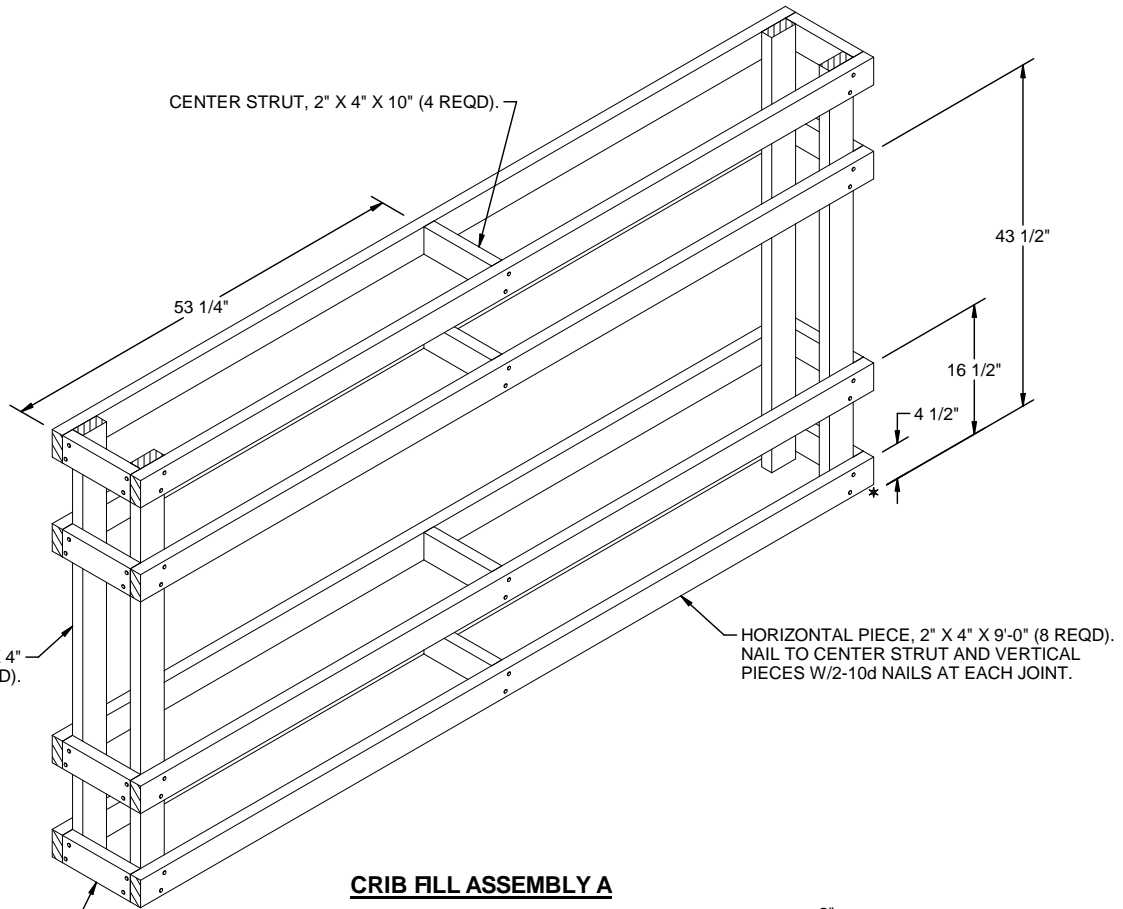

**CRIB FILL ASSEMBLY A**

STRUT, 2" X 4" X 10" (8 REQD).  
NAIL TO VERTICAL PIECES  
W/2-10d NAILS AT EACH END.

**NOTE:** FOR ONE HIGH LOADS WITH EITHER ASSEMBLY,  
ELIMINATE THE TOP FOUR HORIZONTAL PIECES AND  
TOP SIX STRUTS (WHERE APPROPRIATE), AND  
SHORTEN VERTICAL PIECES TO 16 1/2".

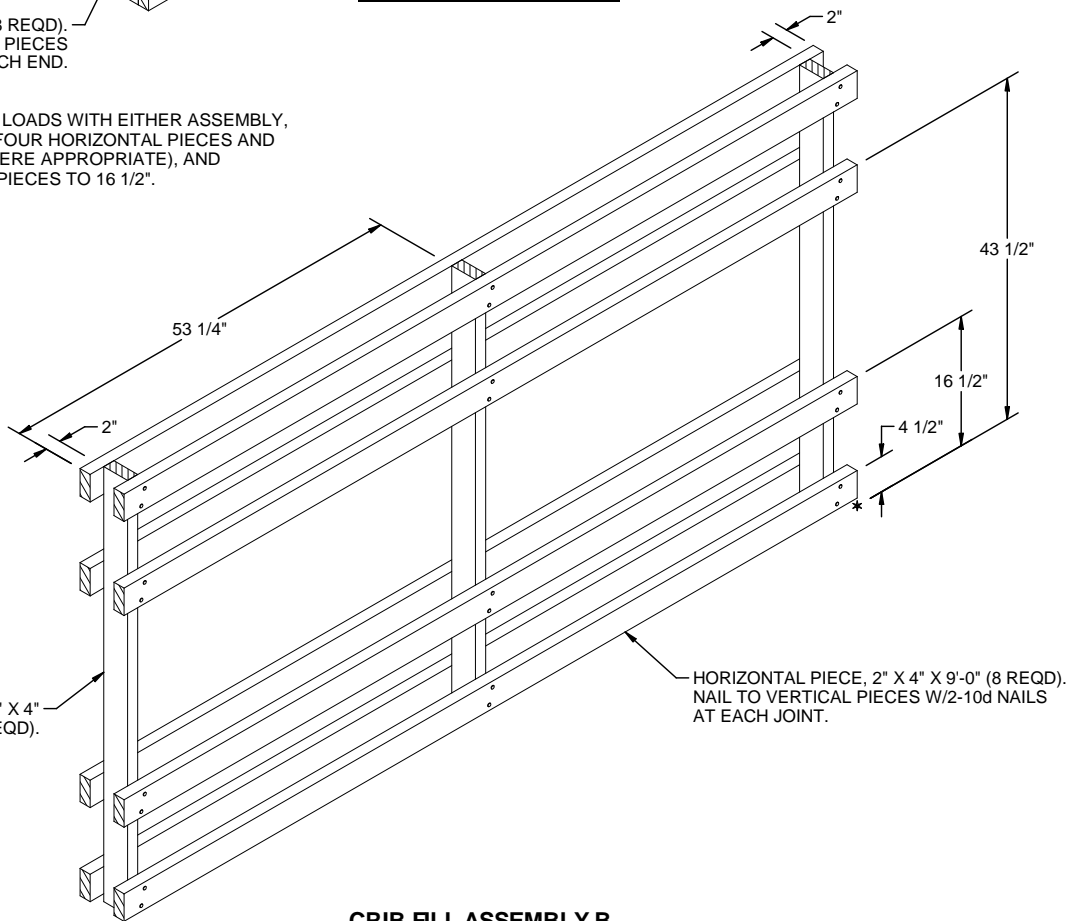

**CRIB FILL ASSEMBLY B**