

LOADING AND BRACING (TL & LTL) IN VAN TRAILERS* OF HARPOON MISSILES (AGM-84 OR ATM-84) PACKED IN MK607 MOD 0 CONTAINERS

INDEX

<u>ITEM</u>	<u>PAGE(S)</u>
GENERAL NOTES AND MATERIAL SPECIFICATIONS - - - - -	2
MK607 MOD 0 CONTAINER DETAIL - - - - -	3
12 UNIT LOAD IN A 48'-0" LONG BY 8'-2" WIDE VAN TRAILER - - - - -	4-5
10 UNIT LOAD IN A 53'-0" LONG BY 8'-2" WIDE VAN TRAILER - - - - -	6-7
8 UNIT LOAD IN A 45'-0" LONG BY 7'-8" WIDE VAN TRAILER - - - - -	8-9
TYPICAL LTL (2 UNIT LOAD) - - - - -	10-11
DETAILS - - - - -	12-14

DISTRIBUTION STATEMENT A:

APPROVED FOR PUBLIC RELEASE
DISTRIBUTION IS UNLIMITED.

***CAUTION:** THE PROCEDURES SHOWN HEREIN ARE ONLY APPLICABLE TO HIGHWAY
MOVEMENTS, NOT TRAILER-ON-FLATCAR(TOFC) MOVEMENTS.

U.S. ARMY MATERIEL COMMAND DRAWING

<p>APPROVED, U.S. ARMY JOINT MUNITIONS COMMAND</p> <p>RUS.ALLEN.J .1230354282</p> <p><small>Digitally signed by RUS.ALLEN.J.1230354282 DN: cn=US, ou=U.S. Government, ou=DoD, ou=PKI, ou=USA, cni=RUS.ALLEN.J.1230354282 Date: 2011.07.06 08:41:45 -0500</small></p>	<p>CAUTION: VERIFY PRIOR TO USE AT WWW.DAC.ARMY.MIL THAT THIS IS THE MOST CURRENT VERSION OF THIS DOCUMENT. THIS IS PAGE 1 OF 14.</p>			
	<p>DO NOT SCALE</p>		<p>JULY 2011</p>	
	<p>ENGINEER OR TECHNICIAN</p>	<p>BASIC REV.</p>	<p>RICHARD GARSIDE</p>	
<p>APPROVED BY ORDER OF COMMANDING GENERAL, U.S. ARMY MATERIEL COMMAND</p> <p>CARNEY.GARY.BURTON.1038708038</p> <p><small>Digitally signed by CARNEY.GARY.BURTON.1038708038 DN: cn=US, ou=U.S. Government, ou=DoD, ou=PKI, ou=USA, cni=CARNEY.GARY.BURTON.1038708038 Date: 2011.07.18 07:47:04 -0500</small></p>	<p>TRANSPORTATION ENGINEERING DIVISION</p>	<p>FIEFFER.LAURA .A.1230375727</p> <p><small>Digitally signed by FIEFFER.LAURA.A.1230375727 DN: cn=US, ou=U.S. Government, ou=DoD, ou=PKI, ou=USA, cni=FIEFFER.LAURA.A.1230375727 Date: 2011.06.27 22:29:51 -0500</small></p>	<p>TESTED</p>	<p>CLASS</p>
	<p>VALIDATION ENGINEERING DIVISION</p>	<p>BARICKMAN. PHILIP.W.123 0202202</p> <p><small>Digitally signed by BARICKMAN.PHILIP.W.12302022 DN: cn=US, ou=U.S. Government, ou=DoD, ou=PKI, ou=USA, cni=BARICKMAN.PHILIP.W.12302022 Date: 2011.06.28 07:31:31 -0500</small></p>		<p>DIVISION</p>
<p>U.S. ARMY DEFENSE AMMUNITION CENTER</p>	<p>ENGINEERING DIRECTORATE</p>	<p>BEAVER.JERRY .W.1230949952</p> <p><small>Digitally signed by BEAVER.JERRY.W.1230949952 DN: cn=US, ou=U.S. Government, ou=DoD, ou=PKI, ou=USA, cni=BEAVER.JERRY.W.1230949952 Date: 2011.06.29 12:18:07 -0500</small></p>		<p>DRAWING</p>
				<p>FILE</p>
			<p>19</p>	<p>48</p>
			<p>8740</p>	<p>SP11J111</p>

GENERAL NOTES

- A. THIS DOCUMENT HAS BEEN PREPARED AND ISSUED IN ACCORDANCE WITH AR 740-1 AND AUGMENTS TM 743-200-1 (CHAPTER 5).
- B. THE SPECIFIED OUTLOADING PROCEDURES ARE APPLICABLE TO LOADS OF HARPOON MISSILES PACKED IN MK607 MOD 0 CONTAINER. SUBSEQUENT REFERENCE TO CONTAINER HEREIN MEANS THE CONTAINER WITH MISSILE ITEMS. SEE PAGE 3 AND NAVAL SEA SYSTEMS COMMAND DRAWING DL2645309 FOR DETAILS OF THE CONTAINER.
- C. THE OUTLOADING PROCEDURES DEPICTED WITHIN THIS DOCUMENT ARE APPLICABLE FOR SHIPMENTS IN CONVENTIONAL TYPE VAN TRAILERS AND APPLY TO TRAILERS HAVING WOOD, OR WOOD AND METAL, OR ALL METAL FLOORS. REGARDLESS OF THE DIMENSIONS OF THE VAN TRAILERS SHOWN, THE PROCEDURES ARE ALSO APPLICABLE FOR TRAILERS WHICH ARE 89" THRU 99" IN WIDTH AND FOR TRAILERS OF OTHER LENGTHS FROM THE SHORTEST TO THE LONGEST AVAILABLE (REF: 24' TO 53'), AND FOR STRAIGHT TRUCK VANS. THE SPECIFIED BRACING IS ADEQUATE FOR LOADS WEIGHING UP TO AND INCLUDING THE MAXIMUM WEIGHTS PERMITTED BY LAW.
- D. SELECTION OF A VEHICLE FOR THE TRANSPORT OF THE DESIGNATED ITEM IS THE RESPONSIBILITY OF THE ORIGINATING CARRIER AND THE SHIPPER. ONLY VEHICLES IN ACCORDANCE WITH THE REQUIREMENTS OF THE APPLICABLE REGULATORY DOCUMENTS WILL BE SELECTED FOR USE.
- E. GROSS WEIGHT AND AXLE DISTRIBUTION OF WEIGHT FOR A LOAD WILL BE THE RESPONSIBILITY OF THE CARRIER. THE CARRIER WILL ADVISE THE SHIPPER OF APPLICABLE LOADING REQUIREMENTS, AND THE SHIPPER WILL LOAD ACCORDINGLY. THE TOTAL WEIGHT OF THE LADING, OF THE DUNNAGE, OF THE TRACTOR, AND OF THE SEMITRAILER CARRYING THE LADING MUST NOT EXCEED THE MAXIMUM GROSS WEIGHT ALLOWED FOR THE STATE OR STATES THRU WHICH THE LOAD IS TO BE TRANSPORTED BY MOTOR CARRIER. LIKEWISE, THE GROSS WEIGHT ON A SINGLE OR TANDEM AXLE MUST NOT EXCEED THE MAXIMUM ALLOWABLE WEIGHT. IF THERE IS ANY DOUBT AS TO WHETHER THE TOTAL GROSS WEIGHT OR AXLE WEIGHT EXCEEDS THE MAXIMUM ALLOWED, WEIGHT SHOULD BE VERIFIED BY ACTUALLY WEIGHING THE LOADED VEHICLE.
- F. **NOTE:** A SHIPMENT WILL BE POSITIONED IN THE TRAILER CONSISTENT WITH STATE WEIGHT LAWS. THE NUMBER OF LADING UNITS MAY BE ADJUSTED TO FIT THE SIZE OF THE TRAILER TO BE LOADED OR THE QUANTITY TO BE SHIPPED. COMBINATIONS OF THE OUTLOADING PROCEDURES SPECIFIED MAY BE USED, HOWEVER, THE APPROVED METHODS SHOWN MUST BE FOLLOWED AS CLOSELY AS POSSIBLE FOR BLOCKING, BRACING, AND STAYING OF THE DESIGNATED ITEMS.
- G. THE "LOAD AS SHOWN" FOR MOST OF THE FULL LOADS DEPICTED HEREIN IS BASED ON AN APPROXIMATE LADING WEIGHT OF 34,000 POUNDS. THE SPECIFIED BLOCKING AND BRACING FOR THE FULL LOADS IS ADEQUATE FOR THE RETENTION OF LOADS, UP TO 45,000 POUNDS, IF IT IS DESIRED TO INCREASE THE LADING WEIGHT.
- H. OTHER TYPES OF LADING ITEMS MAY BE LOADED ON A TRAILER WHICH IS PARTIALLY LOADED WITH THE DESIGNATED ITEM, PROVIDING THE TOTAL LOAD IS COMPATIBLE, EXISTING DIRECTIVES ARE NOT VIOLATED, AND THE OTHER LADING ITEMS ARE BLOCKED AND BRACED TO EQUAL THE BLOCKING AND BRACING CRITERIA SPECIFIED HEREIN.
- J. SOME LOADS ARE SHOWN IN TRAILERS HAVING ROUNDED CORNERS AT THE FORWARD END. IF THE CONVENTIONAL VAN TRAILER BEING USED IS EQUIPPED WITH A SQUARE FRONT OR WITH AN INSTALLED BULKHEAD, OMIT THE FORWARD BLOCKING ASSEMBLY, AND POSITION THE CONTAINERS DIRECTLY AGAINST THE FORWARD PORTION OF THE TRAILER.
- K. WHEN STEEL STRAPPING IS SEALED AT AN END-OVER-END LAP JOINT, A MINIMUM OF ONE SEAL WITH TWO PAIR OF NOTCHES WILL BE USED TO SEAL THE JOINT WHEN A NOTCH-TYPE SEALER IS BEING USED. A MINIMUM OF TWO SEALS, BUTTED TOGETHER WITH TWO PAIR OF CRIMPS PER SEAL WILL BE USED TO SEAL THE JOINT WHEN A CRIMP-TYPE SEALER IS BEING USED. REFER TO THE "END-OVER-END LAP JOINT DETAILS" ON PAGE 3 FOR GUIDANCE.

(CONTINUED AT RIGHT)

MATERIAL SPECIFICATIONS

- LUMBER - - - - - : SEE TM 743-200-1 (DUNNAGE LUMBER) AND VOLUNTARY PRODUCT STANDARD PS 20.
- NAILS - - - - - : ASTM F1667; COMMON STEEL NAIL (NLCMS OR NLCMMS).
- STRAPPING, STEEL - - : ASTM D3953; FLAT STRAPPING, TYPE 1, HEAVY DUTY, FINISH A, B (GRADE 2), OR C.
- SEAL, STRAP - - - - : ASTM D3953; CLASS H, FINISH A, B (GRADE 2), OR C, DOUBLE NOTCH TYPE, STYLE I, II, OR IV.
- ANTI-CHAFING MATERIAL - - - - - : MIL-PRF-121 (OR EQUAL); NEUTRAL BARRIER MATERIAL.

(GENERAL NOTES CONTINUED)

- L. A STAGGERED NAILING PATTERN WILL BE USED WHEREVER POSSIBLE WHEN NAILS ARE DRIVEN INTO JOINTS OF DUNNAGE ASSEMBLIES. ALSO, A STAGGERED NAILING PATTERN WILL BE USED WHEN DUNNAGE IS NAILED TO THE FLOOR OF THE TRANSPORTING VEHICLE, OR WHEN LAMINATING DUNNAGE. THE NAILING PATTERN WILL BE ADJUSTED AS REQUIRED SO THAT A NAIL DOES NOT PENETRATE INTO OR NEAR A CRACK BETWEEN FLOOR BOARDS. ADDITIONALLY, THE NAILING PATTERN FOR AN UPPER PIECE OF LAMINATED DUNNAGE WILL BE ADJUSTED AS REQUIRED SO THAT A NAIL FOR THAT PIECE WILL NOT BE DRIVEN THROUGH THE PIECE ONTO OR RIGHT BESIDE A NAIL IN A LOWER PIECE.
- M. POWER DRIVEN STAPLES MAY BE USED AS ALTERNATIVE FASTENERS FOR NAILS WHEN CONSTRUCTING DUNNAGE ASSEMBLIES THAT ARE TO BE USED IN THE DELINEATED TRAILER LOADS SHOWN THROUGHOUT THIS DRAWING. THE STAPLES TO BE USED MUST BE EQUAL IN LENGTH TO THE SPECIFIED NAIL SIZE AND MUST BE SUBSTITUTED ON A ONE STAPLE FOR ONE NAIL BASIS. STAPLES WHICH ARE 2-1/2" OR LESS IN LENGTH SHOULD BE IN ACCORDANCE WITH ASTM F1667 AS NEARLY AS PRACTICABLE. STAPLES THAT ARE LONGER THAN 2-1/2" WILL BE A COMMERCIAL GRADE, OF A QUALITY EQUIVALENT TO THOSE MANUFACTURED BY SENCO PRODUCTS INCORPORATED. **NOTE:** STAPLES WILL NOT BE SUBSTITUTED FOR NAILS IN ANY LOAD RESTRAINING FLOOR DUNNAGE APPLICATION.
- N. THE UNBLOCKED SPACE ACROSS THE WIDTH OF A LOAD BAY IS NOT TO EXCEED 6". EXCESSIVE SLACK CAN BE ELIMINATED FROM A LOAD BY LAMINATING ADDITIONAL PIECES OF APPROPRIATE THICKNESS TO THE CRIB FILL ASSEMBLIES. NAIL EACH ADDITIONAL PIECE TO THE HORIZONTAL PIECE W/1 APPROPRIATELY SIZED NAIL EVERY 12". ADDITIONALLY, THE LENGTH OF THE STRUTS USED IN THESE ASSEMBLIES MAY BE ADJUSTED AS REQUIRED TO FACILITATE VARIANCE IN THE SIZE OF THE CONTAINER.
- O. **CAUTION:** WHEN POWER OR PNEUMATIC NAILERS ARE BEING USED IN THE APPLICATION OF NAILED FLOORLINE BLOCKING OR BRACING, CONTAINERS BEING LOADED INTO THE CONVEYANCE MUST BE POSITIONED TO ALLOW A CLEAR PATH OF EXIT FOR THE OPERATOR AT ALL TIMES, SHOULD AN EMERGENCY EXIT BECOME NECESSARY.
- P. IF THE SPACE AT THE REAR OF THE LOAD, BETWEEN THE CONTAINERS AND THE REAR DOOR MEASURES 1-1/2" OR LESS REAR BLOCKING IS NOT REQUIRED. IF THE SPACE AT THE REAR OF THE LOAD IS GREATER THAN 1-1/2" BUT LESS THAN 9". USE THE "REAR BLOCKING ASSEMBLY A" AS SHOWN ON PAGE 13. IF THE VOID AT THE REAR OF THE LOAD IS 9" OR GREATER, USE THE "REAR BLOCKING ASSEMBLY B" AS SHOWN ON PAGE 13. **NOTE:** REAR BLOCKING ASSEMBLIES MAY BE REPLACED WITH NAILED HEADERS AT THE REAR OF THE LOAD, PROVIDED THE TRAILER IS CONFIGURED SUCH AS TO ALLOW NAILING IN THE AREA IN QUESTION. REFER TO THE LOAD ON PAGE 6 AND THE HEADER NAILING CHARTS ON PAGE 7 FOR GUIDANCE. **CAUTION:** THE NAILED HEADER METHOD IS REQUIRED WHEN LOADING VAN TRAILERS EQUIPPED WITH ROLL-UP TYPE DOORS.
- Q. PORTIONS OF THE TRAILERS, SUCH AS SIDEWALLS, ENDWALLS, AND ROOFS, HAVE NOT BEEN SHOWN IN THE LOAD VIEWS FOR CLARITY PURPOSES.
- R. THESE PROCEDURES CAN ALSO BE UTILIZED FOR THE SHIPMENT OF MK607 CONTAINERS WHEN THEY ARE LOADED WITH AN ITEM OTHER THAN THE SPECIFIED MISSILE, OR WHEN THEY ARE EMPTY.
- S. DUNNAGE LUMBER SPECIFIED IS OF NOMINAL SIZE. FOR EXAMPLE, 1" X 4" MATERIAL IS ACTUALLY 3/4" THICK BY 3-1/2" WIDE AND 2" X 6" MATERIAL IS ACTUALLY 1-1/2" THICK BY 5-1/2" WIDE.
- T. ANTI-CHAFING MATERIAL MAY BE INSTALLED AT POINTS OF CONTACT BETWEEN CONTAINER AND STEEL STRAPPING, IF DESIRED, TO PREVENT CHAFING DAMAGE TO CONTAINER PAINT AND MARKINGS.
- U. CONVERSION TO METRIC EQUIVALENTS: DIMENSIONS WITHIN THIS DOCUMENT ARE EXPRESSED IN INCHES, AND WEIGHTS ARE EXPRESSED IN POUNDS. WHEN NECESSARY, THE METRIC EQUIVALENTS MAY BE COMPUTED ON THE BASIS OF ONE INCH EQUALS 25.4MM, AND ONE POUND EQUALS 0.454 KG.

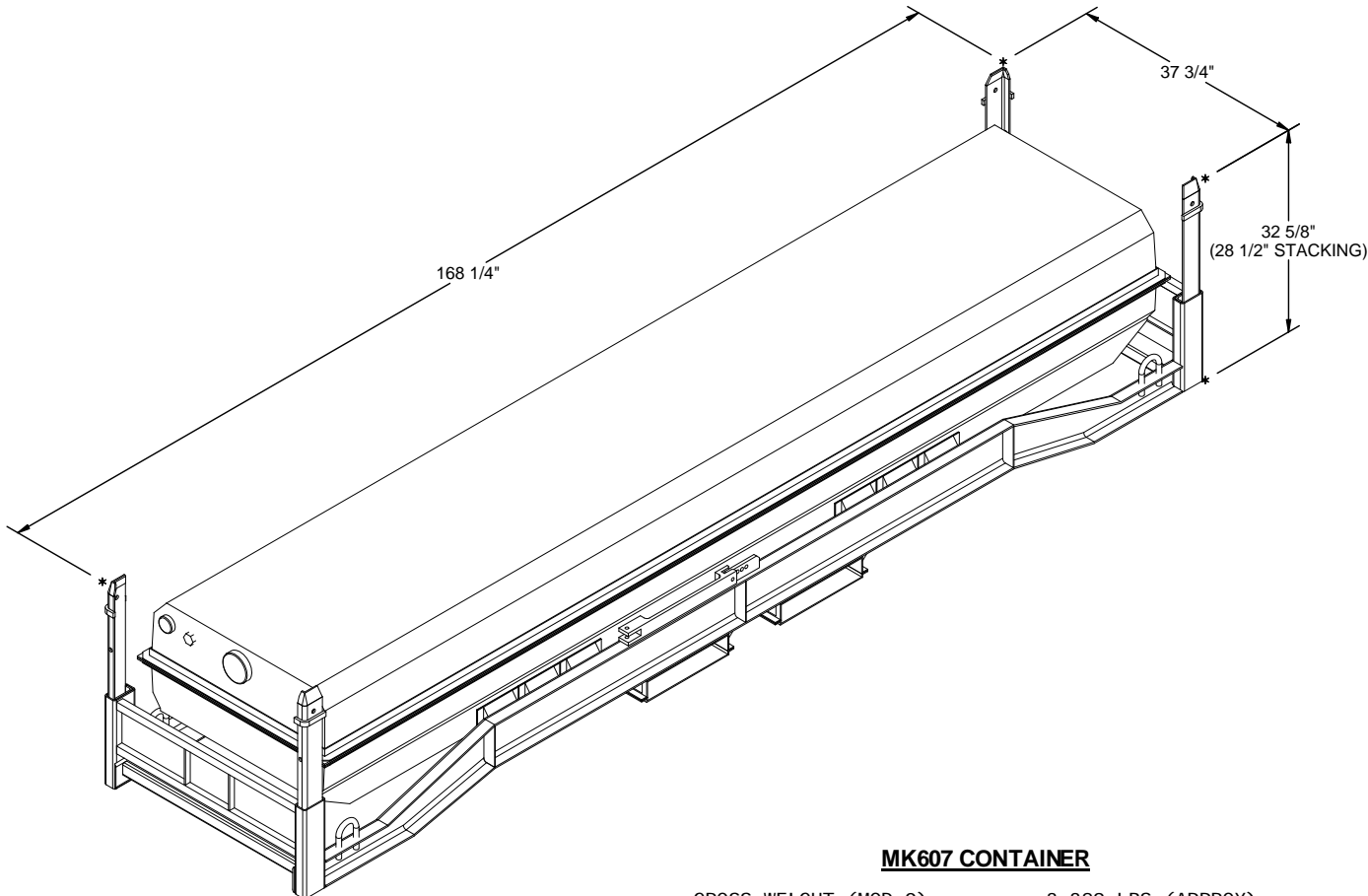

MK607 CONTAINER

GROSS WEIGHT (MOD 0) - - - - 3,389 LBS (APPROX)
 CUBE - - - - - 120.5 CU FT (APPROX)

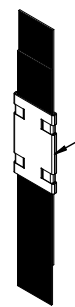

ONE SEAL WITH
TWO PAIR OF
NOTCHES.

STRAP JOINT A

METHOD OF SECURING A
STRAP JOINT WHEN USING
A NOTCH-TYPE SEALER.

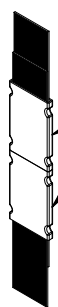

TWO SEALS, BUTTED
TOGETHER, WITH
TWO PAIR OF CRIMPS
EACH SEAL.

STRAP JOINT B

METHOD OF SECURING A
STRAP JOINT WHEN USING
A CRIMP-TYPE SEALER.

END-OVER-END LAP JOINT DETAILS

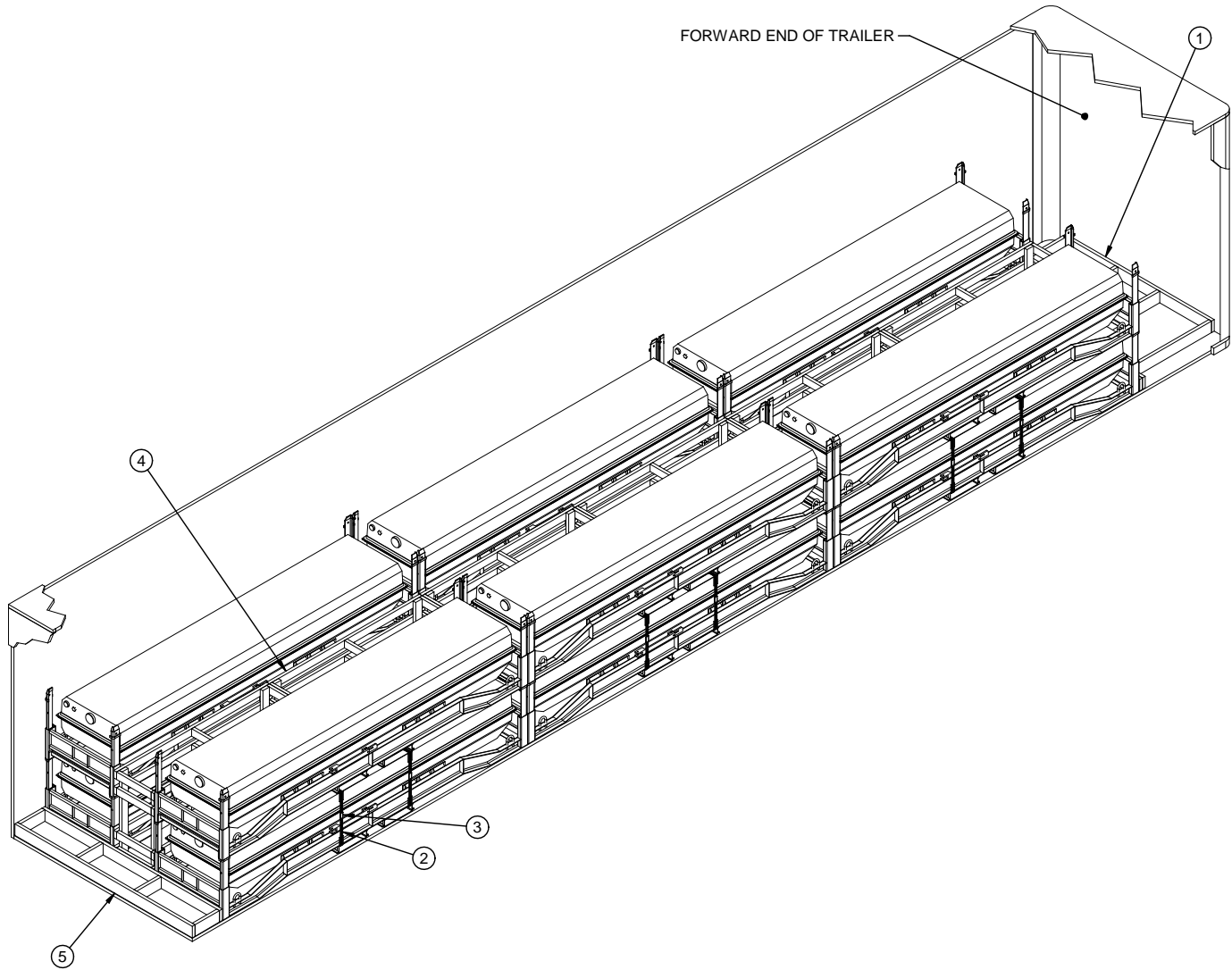

ISOMETRIC VIEW

KEY NUMBERS

- ① FORWARD BLOCKING ASSEMBLY B (1 REQD). SEE THE DETAIL ON PAGE 12.
- ② STACK UNITIZING STRAP, 1-1/4" X .035" OR .031" X 11'-0" LONG STEEL STRAPPING (12 REQD, 2 PER STACK). INSTALL THROUGH FORK POCKETS, AS FAR APART AS ALLOWABLE.
- ③ SEAL FOR 1-1/4" STEEL STRAPPING (12 REQD, 1 PER STRAP). DOUBLE NOTCH EACH SEAL.
- ④ CRIB FILL ASSEMBLY (6 REQD). SEE THE DETAIL ON PAGE 14.
- ⑤ REAR BLOCKING ASSEMBLY B (1 REQD). SEE THE DETAIL ON PAGE 13.

BILL OF MATERIAL

LUMBER	LINEAR FEET	BOARD FEET
2" X 4"	533	355
2" X 6"	59	59
NAI LS	NO. REQD	POUNDS
10d (3")	536	8
STEEL STRAPPING, 1-1/4" - 132' REQD - -		19 LBS
SEAL FOR 1-1/4" STRAPPING - 12 REQD - -		1/2 LBS

LOAD AS SHOWN

ITEM	QUANTITY	WEIGHT (APPROX)
MK607 - - - - -	12 - - - - -	40,668 LBS
DUNNAGE - - - - -	- - - - -	856 LBS
TOTAL WEIGHT - - - - -		41,524 LBS

SPECIAL NOTES:

1. A 48'-0" LONG BY 8'-2" WIDE (INSIDE DIMENSION) VAN TRAILER IS SHOWN. TRAILERS OF OTHER DIMENSIONS CAN BE USED.
2. A TRAILER EQUIPPED WITH ROUNDED FRONT CORNERS IS SHOWN. IF THE TRAILER TO BE LOADED HAS A SQUARE FRONT, THE FORWARD BLOCKING ASSEMBLY MAY BE OMITTED AND THE CONTAINERS POSITIONED DIRECTLY AGAINST THE TRAILER FRONT WALL.
3. THE FORWARD BLOCKING ASSEMBLY AND REAR BLOCKING ASSEMBLY MAY BE REPLACED WITH NAILED HEADERS, PROVIDED THE TRAILER IS CONFIGURED SUCH AS TO ALLOW NAILING IN THE AREA IN QUESTION. REFER TO THE LOAD ON PAGE 8 FOR GUIDANCE.
4. IF THE SPACE AT THE REAR OF THE LOAD BETWEEN THE CONTAINERS AND THE REAR DOORS IS 9" OR GREATER, USE THE "REAR BLOCKING ASSEMBLY B" AS SHOWN. IF THE SPACE AT THE REAR OF THE LOAD IS GREATER THAN 1-1/2" BUT LESS THAN 9", USE THE "REAR BLOCKING ASSEMBLY A" AS SHOWN ON PAGE 13. IF THE SPACE AT THE REAR OF THE LOAD IS 1-1/2" OR LESS, REAR BLOCKING IS NOT REQUIRED.
5. THE DEPICTED LOAD CAN BE ADJUSTED TO SUIT THE QUANTITY TO BE SHIPPED, OR TO SUIT THE WEIGHT OF THE UNIT BEING LOADED.

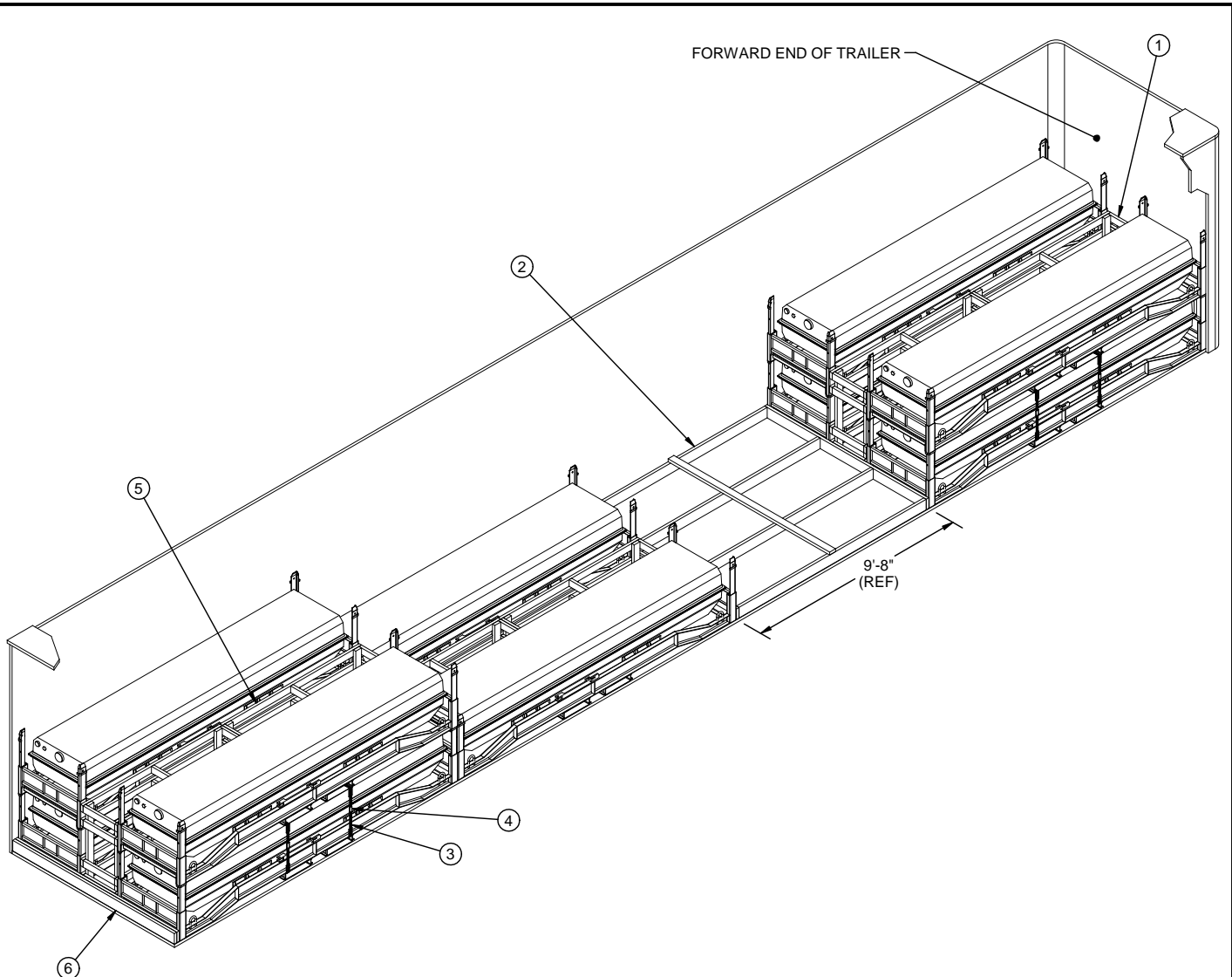

ISOMETRIC VIEW

KEY NUMBERS

- ① FORWARD BLOCKING ASSEMBLY A (1 REQD). SEE THE DETAIL ON PAGE 12.
- ② SPACER ASSEMBLY (1 REQD). SEE THE DETAIL ON PAGE 13.
- ③ STACK UNITIZING STRAP, 1-1/4" X .035" OR .031" X 11'-0" LONG STEEL STRAPPING (8 REQD, 2 PER STACK). INSTALL THROUGH FORK POCKETS, AS FAR APART AS ALLOWABLE.
- ④ SEAL FOR 1-1/4" STEEL STRAPPING (8 REQD, 1 PER STRAP). DOUBLE NOTCH EACH SEAL.
- ⑤ CRIB FILL ASSEMBLY (6 REQD). SEE THE DETAIL ON PAGE 14.
- ⑥ REAR BLOCKING ASSEMBLY A (1 REQD). SEE THE DETAIL ON PAGE 13.

BILL OF MATERIAL

LUMBER	LINEAR FEET	BOARD FEET
2" X 4"	458	306
2" X 6"	101	101
NAI LS	NO. REQD	POUNDS
10d (3")	489	7 1/2
STEEL STRAPPING, 1-1/4" - 88' REQD -		12 1/2 LBS
SEAL FOR 1-1/4" STRAPPING - 8 REQD -		1/2 LBS

LOAD AS SHOWN

ITEM	QUANTITY	WEIGHT (APPROX)
MK607	10	33,890 LBS
DUNNAGE		834 LBS
TOTAL WEIGHT		34,724 LBS

SPECIAL NOTES:

1. A 53'-0" LONG BY 8'-2" WIDE (INSIDE DIMENSION) VAN TRAILER IS SHOWN. TRAILERS OF OTHER DIMENSIONS CAN BE USED.
2. A TRAILER EQUIPPED WITH ROUNDED FRONT CORNERS IS SHOWN. IF THE TRAILER TO BE LOADED HAS A SQUARE FRONT, THE FORWARD BLOCKING ASSEMBLY MAY BE OMITTED AND THE CONTAINERS POSITIONED DIRECTLY AGAINST THE TRAILER FRONT WALL.
3. THE FORWARD BLOCKING ASSEMBLY, REAR BLOCKING ASSEMBLY, AND SPACER ASSEMBLY MAY BE REPLACED WITH NAILED HEADERS, PROVIDED THE TRAILER IS CONFIGURED SUCH AS TO ALLOW NAILING IN THE AREA IN QUESTION. REFER TO THE LOAD ON PAGE 8 FOR GUIDANCE.
4. THE SPACER ASSEMBLY IS USED FOR THE PURPOSE OF PROVIDING FOR PROPER WEIGHT DISTRIBUTION, AND IS SHOWN AS TYPICAL. NOTE THAT A SPACER ASSEMBLY MUST NOT BE POSITIONED ADJACENT TO THE FORWARD BLOCKING ASSEMBLY.
5. IF THE SPACE AT THE REAR OF THE LOAD BETWEEN THE CONTAINERS AND THE REAR DOORS IS GREATER THAN 1-1/2" BUT LESS THAN 9", USE THE "REAR BLOCKING ASSEMBLY A" AS SHOWN. IF THE SPACE AT THE REAR OF THE LOAD IS 9" OR GREATER, USE THE "REAR BLOCKING ASSEMBLY B" AS SHOWN ON PAGE 13. IF THE SPACE AT THE REAR OF THE LOAD IS 1-1/2" OR LESS, REAR BLOCKING IS NOT REQUIRED.
6. THE DEPICTED LOAD CAN BE ADJUSTED TO SUIT THE QUANTITY TO BE SHIPPED, OR TO SUIT THE WEIGHT OF THE UNIT BEING LOADED.

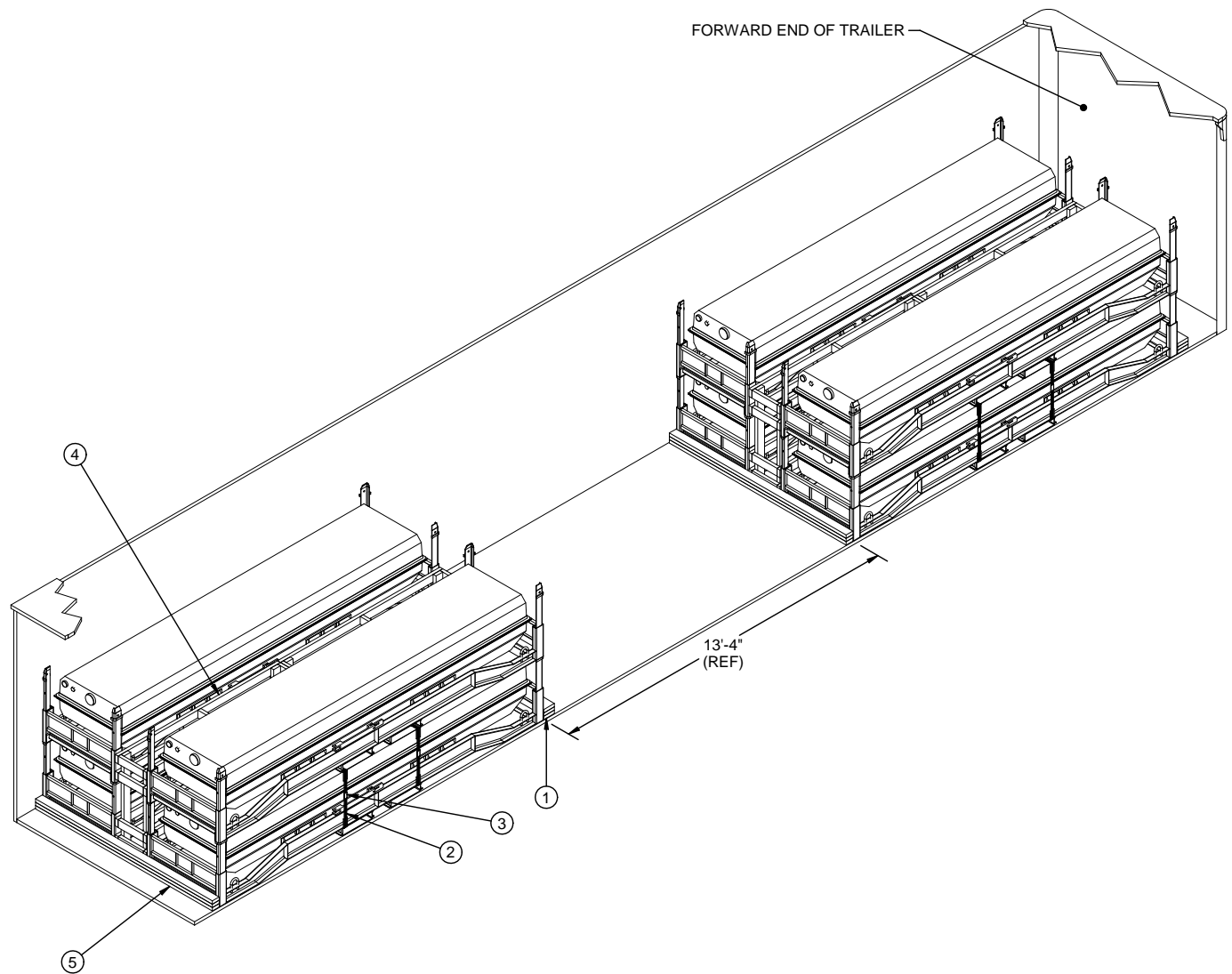

ISOMETRIC VIEW

KEY NUMBERS

- ① FORWARD HEADER, 2" X 6" BY TRAILER WIDTH MINUS 1/2" (TRIPLED) (2 REQD), NAIL THE FIRST PIECE TO THE TRAILER FLOOR W/6-10d NAILS. NAIL THE SECOND PIECE TO THE FIRST AND THE THIRD PIECE TO THE SECOND W/6-20d NAILS EACH. SEE THE HEADER NAILING CHARTS ON PAGE 7.
- ② STACK UNITIZING STRAP, 1-1/4" X .035" OR .031" X 11'-0" LONG STEEL STRAPPING (8 REQD, 2 PER STACK). INSTALL THROUGH FORK POCKETS, AS FAR APART AS ALLOWABLE.
- ③ SEAL FOR 1-1/4" STEEL STRAPPING (8 REQD, 1 PER STRAP). DOUBLE NOTCH EACH SEAL.
- ④ CRIB FILL ASSEMBLY (4 REQD). SEE THE DETAIL ON PAGE 14.
- ⑤ REAR HEADER, 2" X 4" BY TRAILER WIDTH MINUS 1/2" (TRIPLED) (2 REQD). NAIL THE FIRST PIECE TO THE TRAILER FLOOR W/6-10d NAILS. NAIL EACH ADDITIONAL PIECE IN A LIKE MANNER. SEE THE HEADER NAILING CHARTS ON PAGE 7.

BILL OF MATERIAL

LUMBER	LINEAR FEET	BOARD FEET
2" X 4"	377	251
2" X 6"	46	46
NAI LS	NO. REQD	POUNDS
10d (3")	356	5 1/2
20d (4")	24	1
STEEL STRAPPING, 1-1/4" - 88' REQD -		12 1/2 LBS
SEAL FOR 1-1/4" STRAPPING - 8 REQD -		1/2 LBS

LOAD AS SHOWN

ITEM	QUANTITY	WEIGHT (APPROX)
MK607	8	27,112 LBS
DUNNAGE		614 LBS
TOTAL WEIGHT		27,726 LBS

FORWARD HEADER NAILING CHART [•]	
#NAILS	MAX. LOAD WEIGHT (LBS)
3	15,000
4	20,000
5	25,000
6	30,000
7	35,000
8	40,000
9	45,000

- HEADERS AT THE FRONT END OF A LOAD OR AT THE FRONT END OF A DIVIDED LOAD WILL BE DOUBLED 2" X 6" MATERIAL. THE NUMBER OF NAILS INDICATED ABOVE REFERS TO THE NUMBER OF NAILS USED IN EACH LAMINATION OF A HEADER. FOR EXAMPLE 8 NAILS MEANS THE FIRST BOARD IS NAILED TO THE TRAILER FLOOR W/8-10d NAILS, AND THE SECOND BOARD IS LAMINATED TO THE FIRST W/8-20d NAILS, FOR A TOTAL OF 8-10d AND 8-20d NAILS PER HEADER. A MINIMUM OF 6 PAIRS OF NAILS WILL BE USED FOR TRAILER WIDTH HEADERS.

REAR HEADER NAILING CHART [*]	
#NAILS	MAX. LOAD WEIGHT (LBS)
6	15,000
7	17,500
8	20,000
9	22,500
10	25,000
11	27,500
12	30,000
13	32,500
14	35,000
15	37,500
16	40,000
17	42,500
18	45,000

- * HEADERS AT THE REAR OF A FULL LOAD OR AT THE REAR END OF A DIVIDED LOAD WILL BE DOUBLED 2" X 4" MATERIAL. THE NUMBER OF NAILS INDICATED ABOVE REFERS TO THE NUMBER OF NAILS USED IN EACH LAMINATION OF A HEADER. FOR EXAMPLE 8 NAILS MEANS THE FIRST BOARD IS NAILED TO THE TRAILER FLOOR W/8-10d NAILS, AND THE SECOND BOARD IS LAMINATED TO THE FIRST W/8-10d NAILS, FOR A TOTAL OF 16-10d NAILS. A MINIMUM OF 6 PAIRS OF NAILS WILL BE USED FOR TRAILER WIDTH HEADERS. **NOTE:** REAR HEADERS MAY BE HANDLED IN THE SAME MANNER AS FORWARD HEADERS, USING 2" X 6" MATERIAL WITH 10d AND 20d NAILS, IF DESIRED.

SPECIAL NOTES:

1. A 45'-0" LONG BY 7'-8" WIDE (INSIDE DIMENSION) VAN TRAILER WITH NAILABLE FLOOR IS SHOWN. TRAILERS OF OTHER DIMENSIONS CAN BE USED.
2. A TRAILER EQUIPPED WITH ROUNDED FRONT CORNERS IS SHOWN. IF THE TRAILER TO BE LOADED HAS A SQUARE FRONT, THE FORWARD HEADER MAY BE OMITTED AND THE CONTAINERS POSITIONED DIRECTLY AGAINST THE TRAILER FRONT WALL.
3. THE NAILED HEADERS MAY BE REPLACED WITH A FORWARD BLOCKING ASSEMBLY, REAR BLOCKING ASSEMBLY, AND CENTER BLOCKING ASSEMBLY. SEE LOADS ON PAGES 4 AND 6 FOR DETAILS.
4. THE DEPICTED LOAD CAN BE ADJUSTED TO SUIT THE QUANTITY TO BE SHIPPED, OR TO SUIT THE WEIGHT OF THE UNIT BEING LOADED.

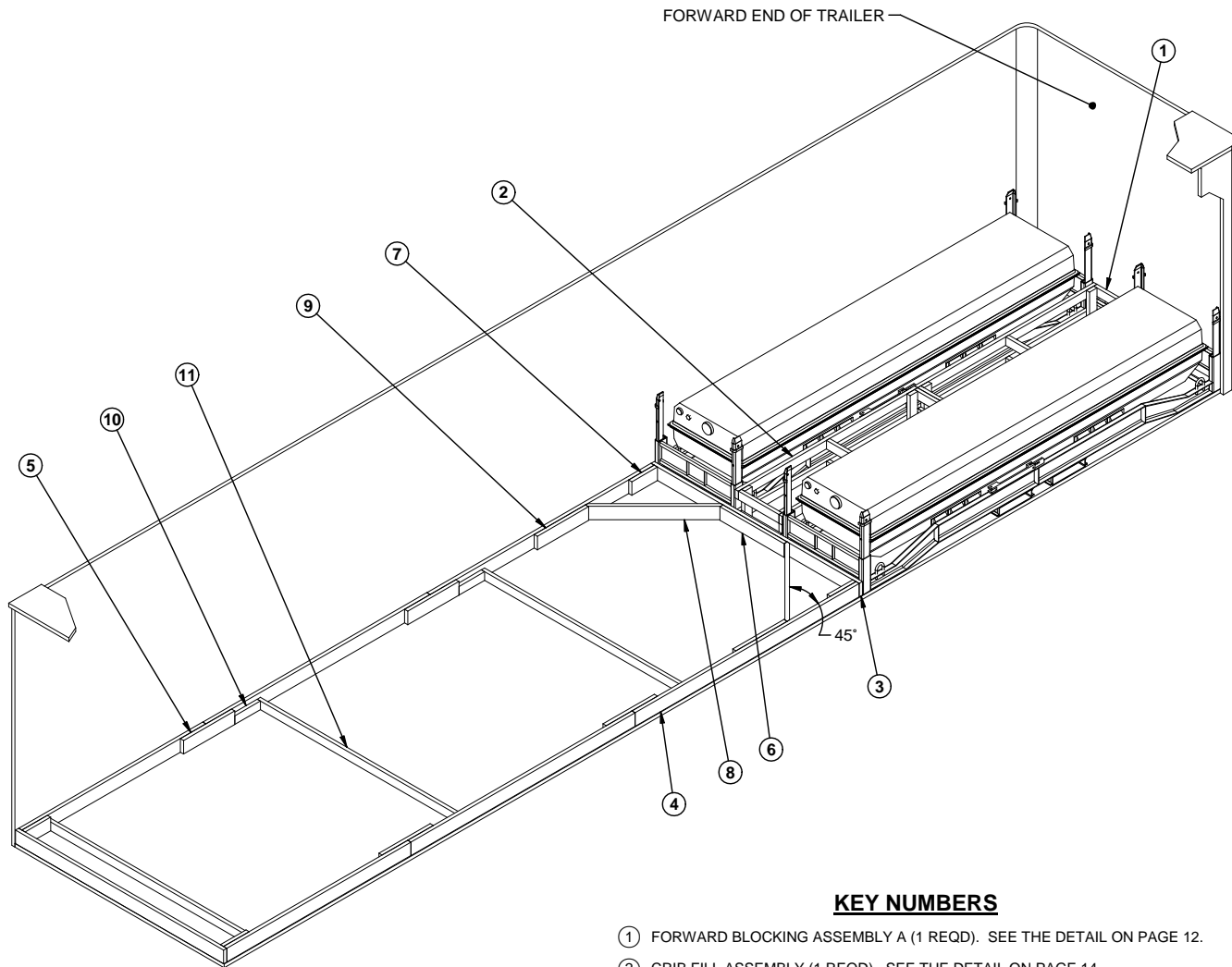

ISOMETRIC VIEW

SPECIAL NOTES:

1. A 2 UNIT LOAD IS SHOWN IN AN 8'-2" WIDE (INSIDE DIMENSION) VAN TRAILER. TRAILERS OF OTHER WIDTHS CAN BE USED.
2. A TRAILER EQUIPPED WITH ROUNDED FRONT CORNERS IS SHOWN. IF THE TRAILER TO BE LOADED HAS A SQUARE FRONT, THE FORWARD BLOCKING ASSEMBLY MAY BE OMITTED AND THE CONTAINERS POSITIONED DIRECTLY AGAINST THE TRAILER FRONT WALL.
3. DEPENDING ON THE NUMBER OF UNITS BEING LOADED, EACH OF THE SIDE STRUTS MAY NEED TO BE FORMED FROM MORE THAN ONE PIECE OF MATERIAL. IF SUCH IS THE CASE, THE SIDE STRUTS MUST BE SPLICED. SPLICING CAN BE ACCOMPLISHED BY CENTERING A 2" X 6" X 24" PIECE ON THE JOINT OF THE SIDE STRUTS AND NAILING IT TO THE SIDE STRUTS W/4-10d NAILS AT EACH END. IF DESIRED, THE STRUT BRACE PIECE(S) MAY BE NAILED TO THE SPLICE PIECES IN LIEU OF USING ADDITIONAL STRUT BRACE CLEATS.
4. ALL LTL LOADS, REGARDLESS OF THEIR SIZE, REQUIRE ONE STRUT BRACE POSITIONED AT THE REAR OF THE TRAILER AND NAILED TO THE POCKET CLEAT. IF THE SIDE STRUTS ARE LONGER THAN 7'-0", AN ADDITIONAL STRUT BRACE AND TWO STRUT BRACE CLEATS MUST BE APPLIED FOR EVERY 7'-0" OF SIDE STRUT LENGTH.
5. THE "K-BRACE" BLOCKING IS ADEQUATE FOR RETAINING A MAXIMUM LTL LOAD OF 20,000 POUNDS.
6. TRAILERS EQUIPPED WITH ROLL-UP TYPE DOORS MAY BE USED; HOWEVER, THE NAILED-HEADER METHOD OF REAR BLOCKING MUST BE INSTALLED IN LIEU OF THE "K-BRACE" TYPE BLOCKING. REFER TO THE LOAD ON PAGE 8 FOR GUIDANCE. NOTE THAT THE NAILED-HEADER METHOD OF REAR BLOCKING MAY ALSO BE USED IN TRAILERS EQUIPPED WITH HINGED DOORS AND NAILABLE FLOORS, AND MAY BE USED IN LIEU OF THE "K-BRACE" PIECES WHICH APPLY TO TRAILERS HAVING NON-NAILABLE FLOORS.

KEY NUMBERS

- ① FORWARD BLOCKING ASSEMBLY A (1 REQD). SEE THE DETAIL ON PAGE 12.
- ② CRIB FILL ASSEMBLY (1 REQD). SEE THE DETAIL ON PAGE 14.
- ③ HEADER, 2" X 6" BY TRAILER WIDTH (2 REQD).
- ④ SIDE STRUT, 2" X 6" BY CUT TO FIT BETWEEN THE FORWARD AND REAR HEADERS (AS REQD). SEE SPECIAL NOTE 3 AT LEFT.
- ⑤ SPLICE PIECE, 2" X 6" X 24" (AS REQD). CENTER ON THE JOINT OF THE SIDE STRUTS AND NAIL W/4-10d NAILS AT EACH END. SEE SPECIAL NOTE 3 AT LEFT.
- ⑥ CENTER CLEAT, 2" X 6" X 30" (1 REQD). NAIL TO THE FORWARD HEADER W/6-10d NAILS.
- ⑦ POCKET CLEAT, 2" X 6" X 12" (4 REQD). NAIL TO A SIDE STRUT W/5-10d NAILS AND TOENAIL TO THE HEADER W/3-12d NAILS.
- ⑧ DIAGONAL BRACE, 2" X 6" BY CUT TO FIT (2 REQD). DOUBLE BEVEL EACH END WITH 45° CUTS. INSTALL AS SHOWN AND TOENAIL TO THE HEADER AND THE SIDE STRUT W/2-16d NAILS AT EACH END.
- ⑨ BACK-UP CLEAT, 2" X 6" X 24" (2 REQD). POSITION ON THE SIDE STRUT TO HOLD THE DIAGONAL BRACE IN PLACE AND NAIL TO THE SIDE STRUT W/8-10d NAILS.
- ⑩ STRUT BRACE CLEAT, 2" X 4" X 12" (AS REQD). NAIL TO THE SIDE STRUT W/3-10d NAILS. SEE SPECIAL NOTE 4 AT LEFT.
- ⑪ STRUT BRACE, 2" X 4" BY TRAILER WIDTH MINUS 3" (CUT TO FIT) (MINIMUM OF ONE REQD). NAIL TO THE POCKET CLEATS AND/OR STRUT BRACE CLEATS W/2-12d NAILS AT EACH END. SEE SPECIAL NOTE 4 AT LEFT.

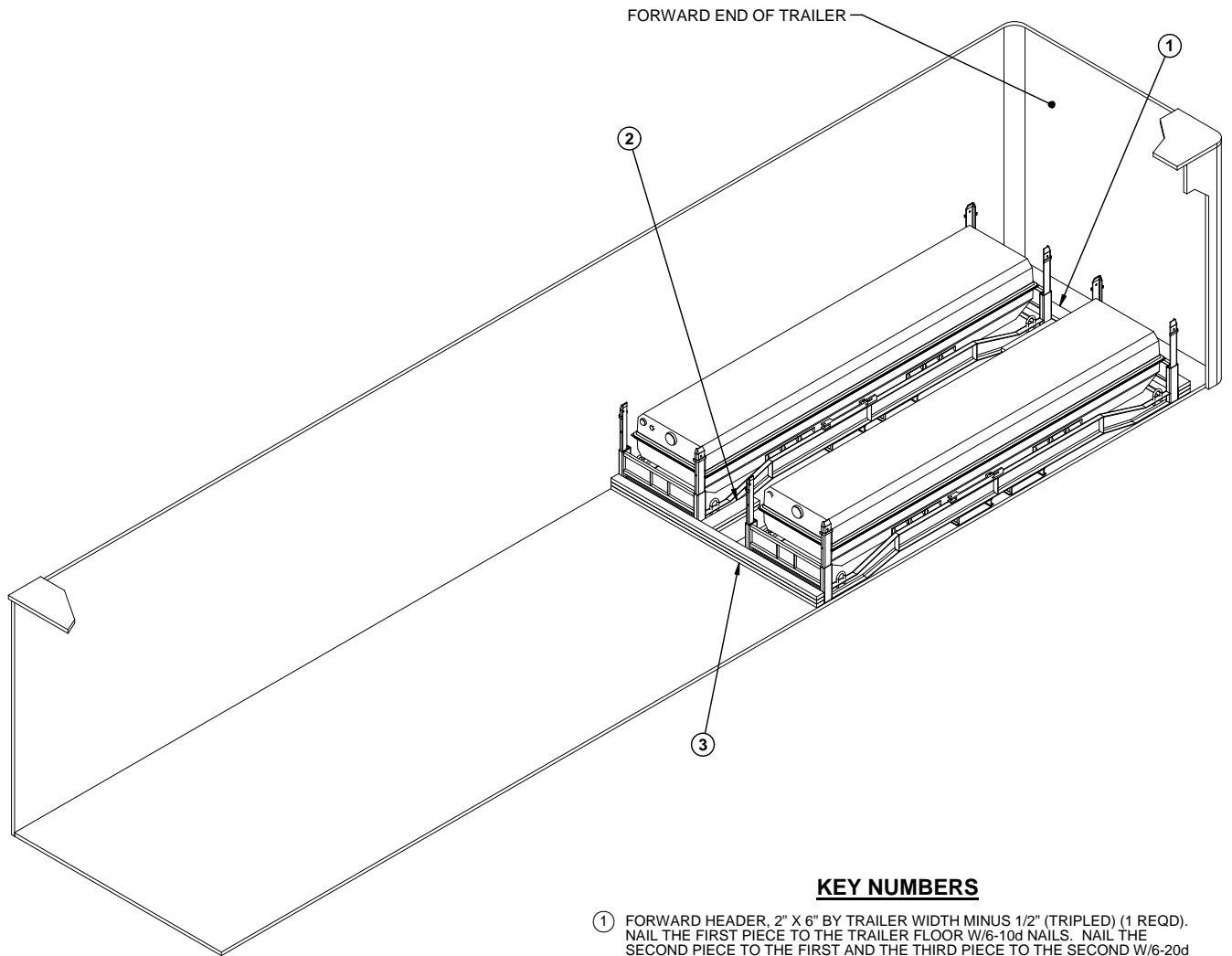

ISOMETRIC VIEW

SPECIAL NOTES:

1. A 2 UNIT LOAD IS SHOWN IN AN 8'-2" WIDE (INSIDE DIMENSION) VAN TRAILER. TRAILERS OF OTHER WIDTHS CAN BE USED.
2. A TRAILER EQUIPPED WITH ROUNDED FRONT CORNERS IS SHOWN. IF THE TRAILER TO BE LOADED HAS A SQUARE FRONT, THE FORWARD HEADER MAY BE OMITTED AND THE CONTAINERS POSITIONED DIRECTLY AGAINST THE TRAILER FRONT WALL.

KEY NUMBERS

- ① FORWARD HEADER, 2" X 6" BY TRAILER WIDTH MINUS 1/2" (TRIPLED) (1 REQD). NAIL THE FIRST PIECE TO THE TRAILER FLOOR W/6-10d NAILS. NAIL THE SECOND PIECE TO THE FIRST AND THE THIRD PIECE TO THE SECOND W/6-20d NAILS EACH. SEE THE HEADER NAILING CHARTS ON PAGE 9.
- ② SIDE BLOCKING, 2" X 6" X 24" (DOUBLED) (4 REQD). POSITION THE FIRST PIECE AGAINST THE CONTAINER AND NAIL THE FIRST PIECE TO THE TRAILER FLOOR W/4-10d NAILS. POSITION THE SECOND PIECE ON TOP OF THE FIRST PIECE AND NAIL TO THE FIRST PIECE W/4-10d NAILS.
- ③ REAR HEADER, 2" X 4" BY TRAILER WIDTH MINUS 1/2" (TRIPLED) (1 REQD). NAIL THE FIRST PIECE TO THE TRAILER FLOOR W/6-10d NAILS. NAIL EACH ADDITIONAL PIECE IN A LIKE MANNER. SEE THE HEADER NAILING CHARTS ON PAGE 9.

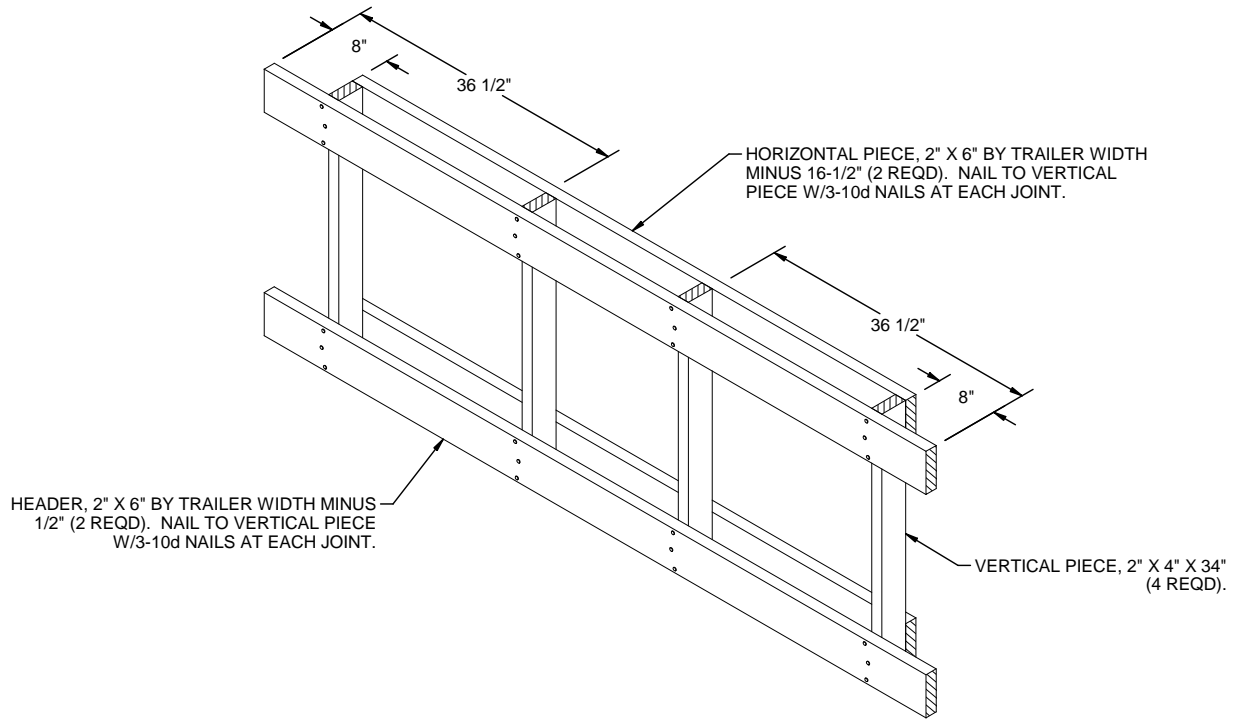

FORWARD BLOCKING ASSEMBLY A

NOTE: FOR ONE HIGH LOADS, ELIMINATE THE TOP HEADER AND TOP HORIZONTAL PIECE, AND SHORTEN VERTICAL PIECES TO 5 1/2".

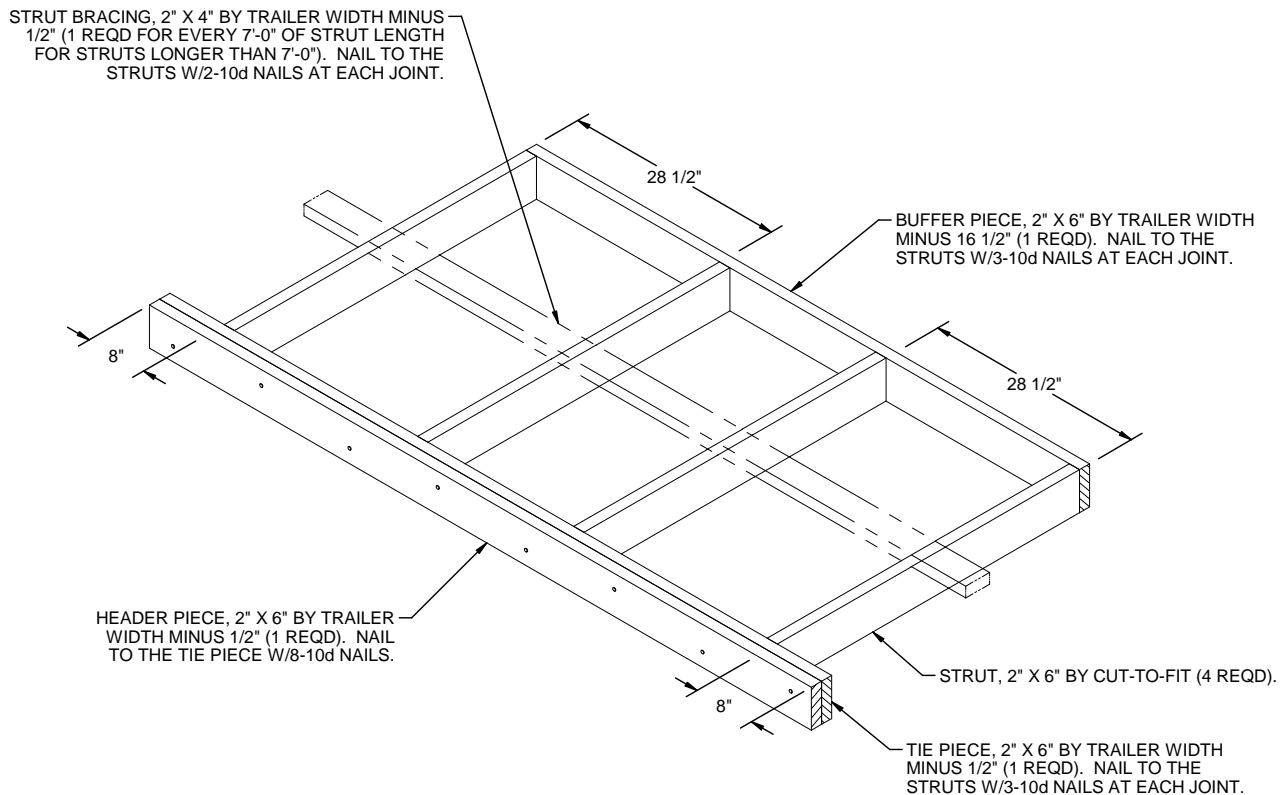

FORWARD BLOCKING ASSEMBLY B

HEADER, 2" X 6" BY TRAILER WIDTH MINUS 1/2" (AS REQD).
LAMINATE FIRST PIECE TO SECOND PIECE W/9-10d NAILS.
LAMINATE EACH ADDITIONAL PIECE IN A LIKE MANNER.

IF THE TRAILER IS EQUIPPED WITH REAR CORNER POSTS, INSTALL
SOLID FILL, 6" WIDE BY 48" LONG BY THE THICKNESS REQUIRED TO
FILL THE EXCESS SPACE BETWEEN THE REAR BLOCKING AND THE
REAR DOORS OF THE TRAILER WHEN THEY ARE CLOSED. NAIL TO
THE REAR BLOCKING W/4 APPLICABLY SIZED NAILS.

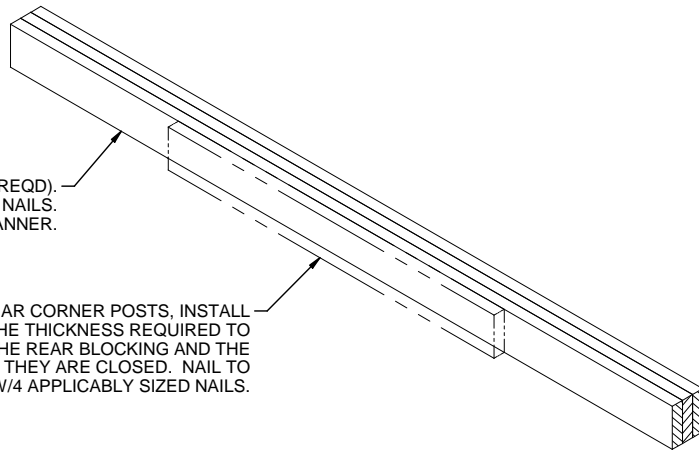

REAR BLOCKING ASSEMBLY A

STRUT BRACING, 2" X 4" BY TRAILER WIDTH MINUS
1/2" (1 REQD FOR EVERY 7'-0" OF STRUT LENGTH
FOR STRUTS LONGER THAN 7'-0"). NAIL TO THE
STRUTS W/2-10d NAILS AT EACH JOINT.

HEADER, 2" X 6" BY TRAILER WIDTH
MINUS 1/2" (2 REQD). NAIL TO THE
STRUTS W/3-10d NAILS AT EACH JOINT.

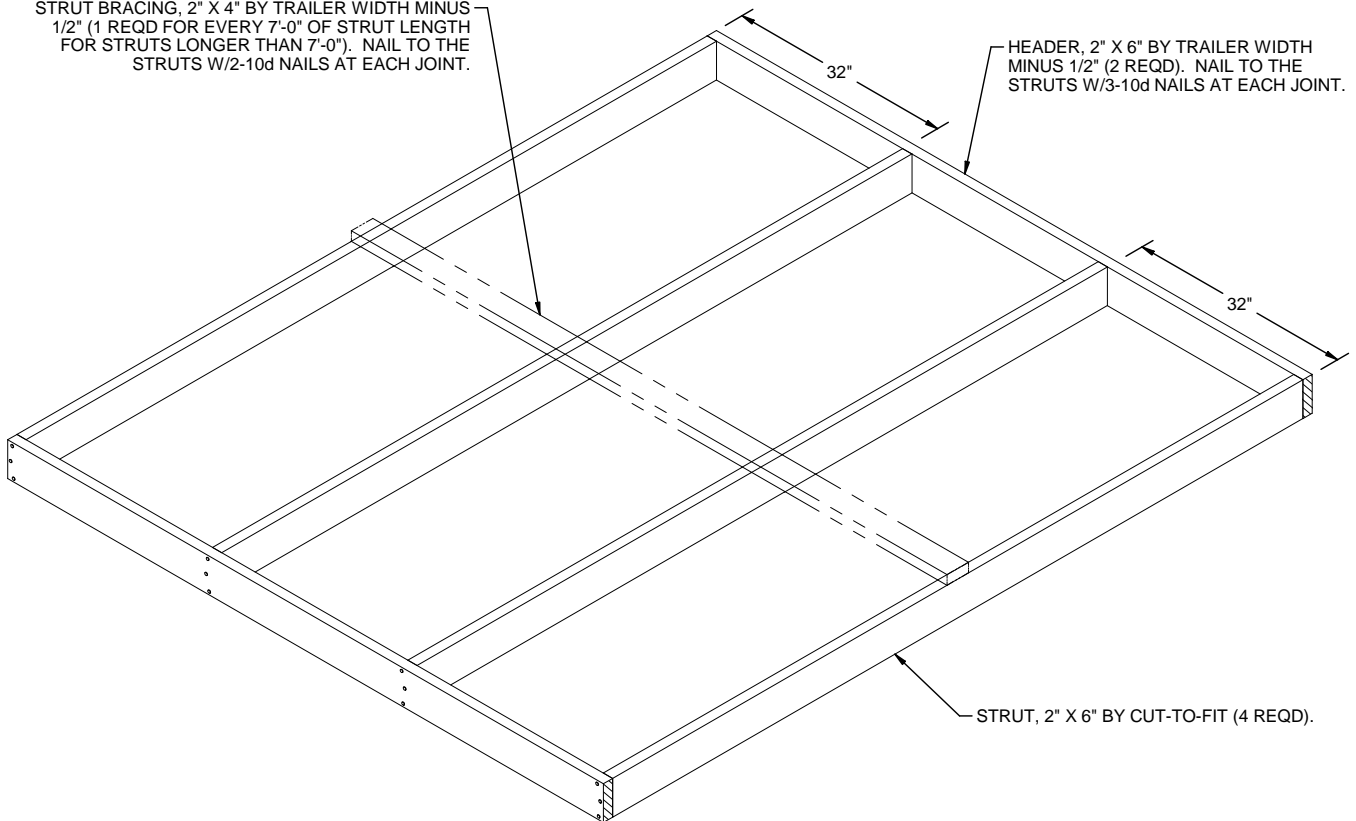

STRUT, 2" X 6" BY CUT-TO-FIT (4 REQD).

SPACER ASSEMBLY/REAR BLOCKING ASSEMBLY B

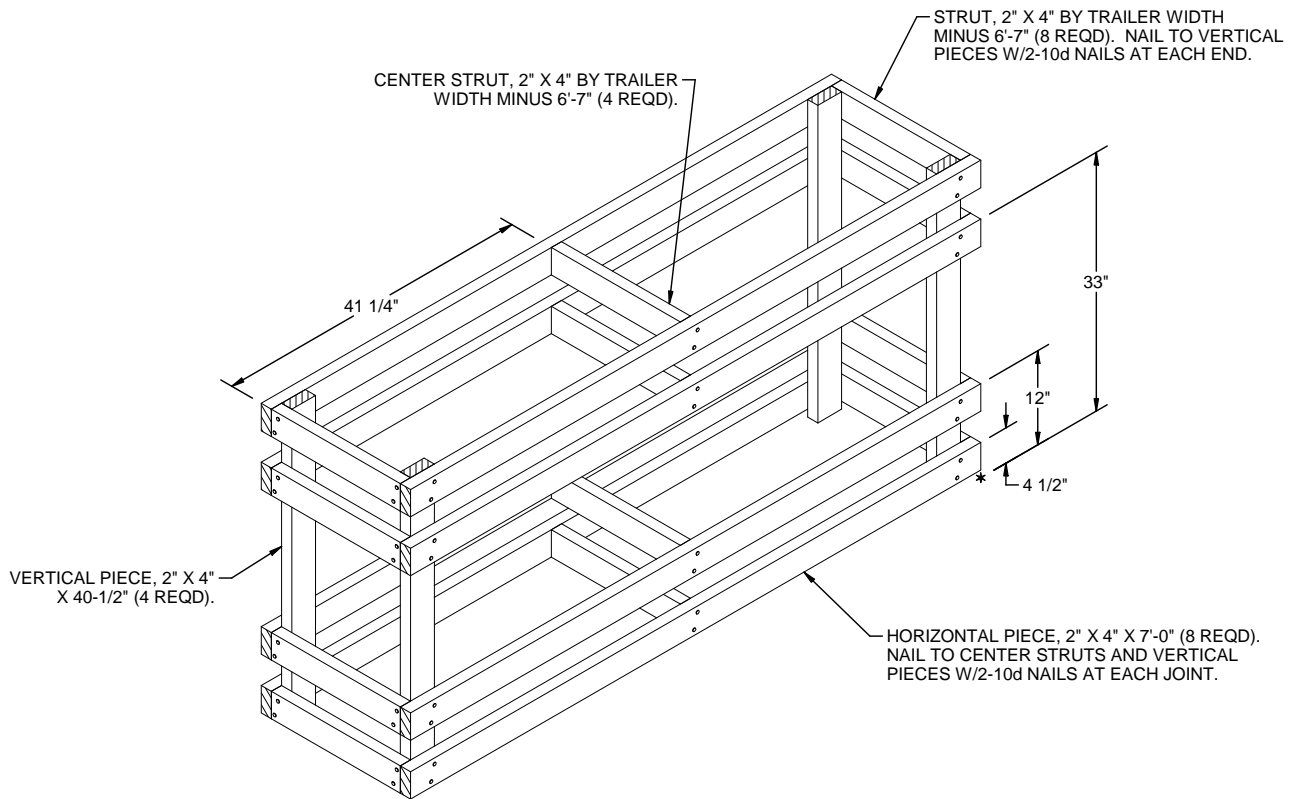

CRIB FILL ASSEMBLY

NOTE: FOR ONE HIGH LOADS, ELIMINATE THE TOP FOUR HORIZONTAL PIECES AND TOP SIX STRUTS, AND SHORTEN VERTICAL PIECES TO 12".