

LOADING AND BRACING[●] IN MILVAN CONTAINERS[⊕] OF BSU-84, BSU-88 OR BSG-92 AIRFOIL GROUP PACKED IN CNU-373/E SHIPPING AND STORAGE CONTAINERS



INDEX

<u>ITEM</u>	<u>PAGE(S)</u>
TYPICAL LOADING PROCEDURES - - - - -	2
GENERAL NOTES AND MATERIAL SPECIFICATIONS - - - - -	3
CNU-373/E CONTAINER DETAILS - - - - -	4
DETAILS - - - - -	5
LESS-THAN-FULL-LOAD PROCEDURE - - - - -	6

● LOADING AND BRACING SPECIFICATIONS SET FORTH WITHIN THIS DRAWING ARE APPLICABLE TO LOADS THAT ARE TO BE SHIPPED BY TRAILER/CONTAINER-ON-FLATCAR (T/COFC) RAIL CARRIER SERVICE. THESE SPECIFICATIONS MAY ALSO BE USED FOR LOADS THAT ARE TO BE MOVED BY MOTOR OR WATER CARRIERS.

⊕ ONLY TYPE II OR TYPE IV MILVAN CONTAINERS WHICH HAVE BEEN MODIFIED TO INCLUDE A MECHANICAL LOAD-BRACING SYSTEM THAT MEETS THE REQUIREMENTS OF MIL-C-52661 WILL BE USED FOR THE MOVEMENT OF AMMUNITION BY T/COFC SERVICE.

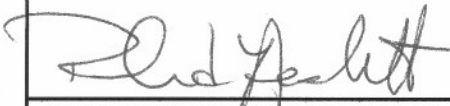
U.S. ARMY MATERIEL COMMAND DRAWING

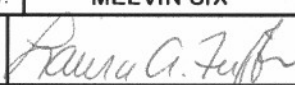
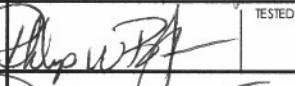
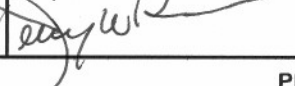
APPROVED, U.S. ARMY JOINT MUNITIONS COMMAND 	CAUTION: VERIFY PRIOR TO USE AT WWW.DAC.ARMY.MIL THAT THIS IS THE MOST CURRENT VERSION OF THIS DOCUMENT. THIS IS PAGE 1 OF 6.						
	DO NOT SCALE				MARCH 2004		
	ENGINEER OR TECHNICIAN	BASIC REV.	MELVIN SIX MELVIN SIX		REVISION NO. 1		NOVEMBER 2006
APPROVED BY ORDER OF COMMANDING GENERAL, U.S. ARMY MATERIEL COMMAND  U.S. ARMY DEFENSE AMMUNITION CENTER	TRANSPORTATION ENGINEERING DIVISION			SEE THE REVISION LISTING ON PAGE 3			
	VALIDATION ENGINEERING DIVISION			CLASS	DIVISION	DRAWING	FILE
	ENGINEERING DIRECTORATE			19	48	8689	SP15J109

PROJECT SP 388-00

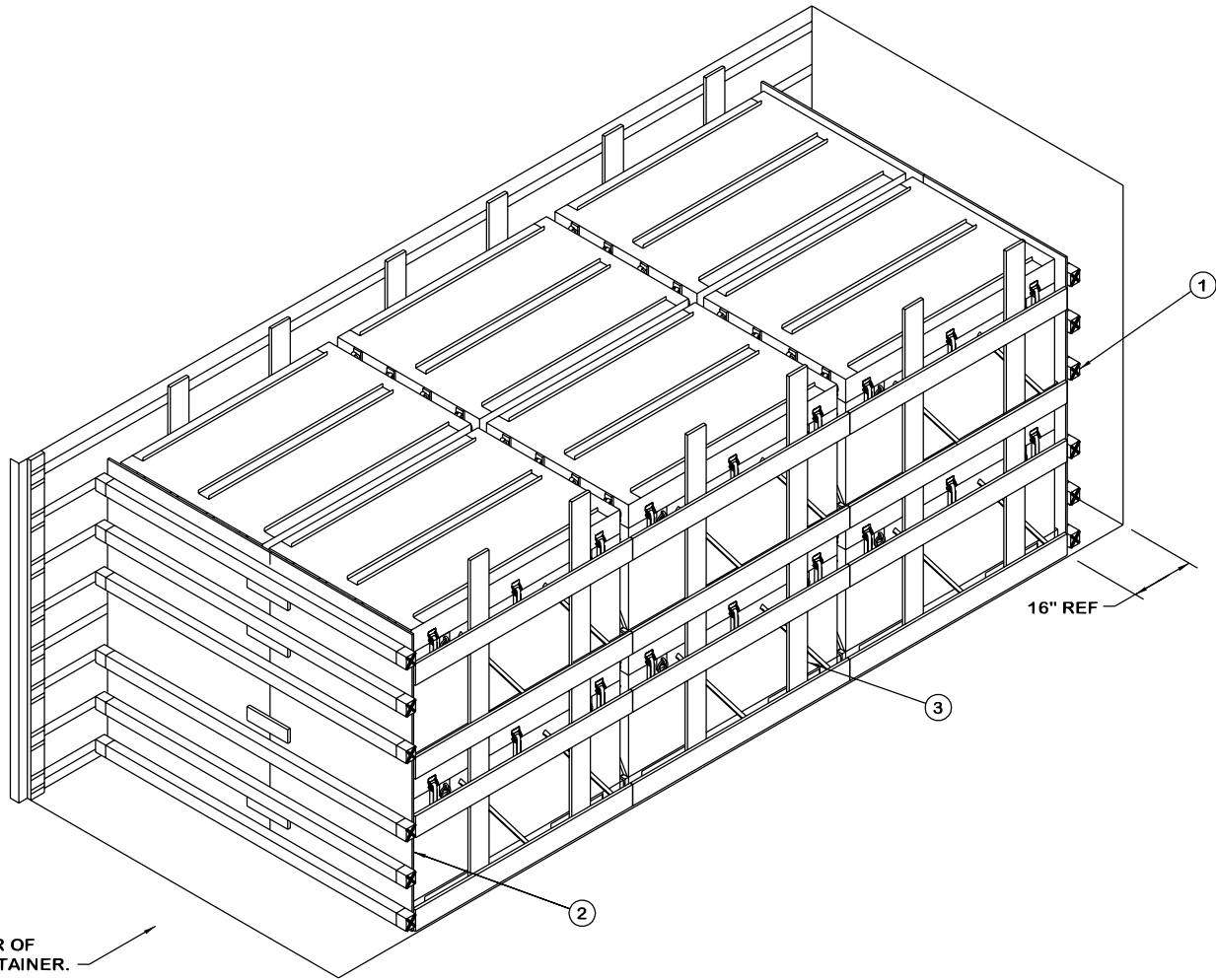

ISOMETRIC VIEW

KEY NUMBERS

- ① CROSS MEMBER (12 REQD). POSITION AS SHOWN IN THE DETAIL ABOVE AT THE 5", 16", 28", 48", 60" AND 72" HEIGHTS.
- ② SEPARATOR GATE (2 REQD). SEE THE DETAIL ON PAGE 5.
- ③ SIDE FILL ASSEMBLY (6 REQD). SEE THE DETAIL ON PAGE 5.

BILL OF MATERIAL

LUMBER	LINEAR FEET	BOARD FEET
1" X 4"	8	3
1" X 6"	214	107
NAILS	NO. REQD	POUNDS
6d (2")	168	1
PLYWOOD, 1/2"	47.50 SQ. FT REQD	66 LBS
CROSS MEMBER		12 REQD

LOAD AS SHOWN

ITEM	QUANTITY	WEIGHT (APPROX)
CNU-373 CONTAINER	12	14,304 LBS
DUNNAGE		286 LBS
CONTAINER		5,700 LBS
TOTAL WEIGHT		20,290 LBS (APPROX)

(GENERAL NOTES CONTINUED)

K. MAXIMUM LOAD WEIGHT CRITERIA:

THE MAXIMUM LOAD WEIGHTS ARE CONTROLLED BY EQUIPMENT CAPABILITY FACTORS. ALTHOUGH THE HEAVIEST MAXIMUM LOADS ARE DELINEATED IN THE LOAD VIEWS, PROVISIONS ARE INCLUDED WITHIN THIS DRAWING SO THAT THE BASIC LOADS CAN BE ADJUSTED TO SATISFY A LESSER QUANTITY OF LADING UNITS. DEPENDING ON TRANSPORTATION ROUTING, IT MAY BE NECESSARY TO REDUCE THE LOAD WEIGHT TO SATISFY "WEIGHT LAWS" OF CERTAIN STATES. ALSO, IT MAY BE NECESSARY TO REDUCE THE LOAD WEIGHT TO SATISFY OTHER WEIGHT RESTRICTIONS IMPOSED ON THE INTERMODAL CONTAINER SYSTEM.

L. SPECIAL T/COFC NOTES:

- 1. CAUTION: LOADED CONTAINERS MUST BE ON CHASSIS EQUIPPED WITH TWO BOGIE ASSEMBLIES WHEN BEING MOVED IN TOFC SERVICE, REGARDLESS OF THE LOAD WEIGHT WITHIN THE CONTAINER.
- 2. LOAD LIMITS OF T/COFC RAIL CARS MUST NOT BE EXCEEDED, NOR WILL A CAR BE LOADED SO THAT THE TRUCK UNDER ONE END OF THE CAR CARRIES MORE THAN ONE-HALF OF THE LOAD LIMIT FOR THAT CAR.
- 3. CHASSIS/CONTAINERS COUPLED INTO A 40-FOOT TRAILER CONFIGURATION MUST BE PLACED AT THE B-END OF A TOFC RAILCAR. THE REAR END OF THE 40-FOOT UNIT WILL OVERHANG THE END OF THE CAR IF IT IS PLACED AT THE A-END. TWENTY-FOOT AND 40-FOOT UNITS CAN BE LOADED ON THE SAME CAR.

M. WHEN LOADING CONTAINERS, THEY ARE TO BE POSITIONED SO AS TO ACHIEVE A TIGHT LOAD (TIGHT AGAINST THE DUNNAGE ASSEMBLIES). THE UNBLOCKED SPACE ACROSS THE WIDTH OF A LOAD BAY IS NOT TO EXCEED 1-1/2". EXCESSIVE SLACK CAN BE ELIMINATED BY LAMINATING ADDITIONAL PIECES OF APPROPRIATE THICKNESS TO THE VERTICAL PIECES ON THE SIDE FILL ASSEMBLIES. NAIL EACH ADDITIONAL PIECE W/1 APPROPRIATELY SIZED NAIL EVERY 12".

N. WHETHER A CONTAINER IS FULL OR IS LOADED WITH A REDUCED QUANTITY OF LADING UNITS, THE LENGTHWISE CENTER OF GRAVITY OF THE LOAD MUST BE WITHIN 12", IN EITHER DIRECTION, OF THE MID-POINT OF THE CONTAINER.

O. THE QUANTITY OF CONTAINERS SHOWN IN THE LOAD ON PAGE 2 MAY BE REDUCED FOR SHIPMENT, IF DESIRED. SEE THE "LESS-THAN-FULL LOAD" DETAIL ON PAGE 6.

P. ANTI-CHAFING MATERIAL MAY BE INSTALLED AT POINTS OF CONTACT BETWEEN CONTAINERS AND THE MILVAN, IF DESIRED, TO PREVENT CHAFING DAMAGE TO CONTAINER PAINT AND MARKINGS.

GENERAL NOTES

- A. THIS DOCUMENT HAS BEEN PREPARED AND ISSUED IN ACCORDANCE WITH AR 740-1 AND AUGMENTS TM 743-200-1 (CHAPTER 5).
- B. THE SPECIFIED OUTLOADING PROCEDURES ARE APPLICABLE TO LOADS OF BSU-84, BSU-88 OR BSG-92 AIRFOIL GROUP PACKED IN CNU-373/E CONTAINERS. SUBSEQUENT REFERENCE TO CONTAINER HEREIN MEANS THE CNU-373 CONTAINER WITH AIRFOIL GROUP INSTALLED. SEE AIR FORCE DRAWING 817218-30 AND PAGE 4 FOR DETAILS OF THE CONTAINER. CAUTION: REGARDLESS OF THE QUANTITY OF UNITS TO BE SHIPPED, THE "MAXIMUM GROSS WEIGHT" OF THE MILVAN MUST NOT BE EXCEEDED.
- C. THE LOADS AS SHOWN ARE BASED ON A 20' LONG BY 8' WIDE BY 8' HIGH MILVAN CONTAINER WITH INSIDE DIMENSIONS OF 19'-4" LONG BY 92" WIDE BY 87" HIGH. THE LOADS ARE DESIGNED FOR TRAILER/CONTAINER-ON-FLATCAR (T/COFC) SHIPMENT.
- D. THE SPECIFIED OUTLOADING PROCEDURES ARE FOR CONTAINERS EQUIPPED WITH SELF-CONTAINED MECHANICAL BRACING DEVICES AS DESCRIBED IN MIL-C-52661. CROSS MEMBER ATTACHMENT FACILITIES WITHIN THESE CONTAINERS MUST PROVIDE FOR THE INSTALLATION OF LOAD BLOCKING CROSS MEMBERS AT THE HEIGHTS SPECIFIED. VOIDS LENGTHWISE WITHIN THE LOAD MUST BE HELD TO A MINIMUM. CROSS MEMBERS MUST BE PLACED AGAINST THE LADING AS TIGHTLY AS THE HOLE SPACING IN THE CROSS MEMBER ATTACHMENT FACILITY PERMITS. SEE THE "FILL DETAIL" BELOW FOR ADDITIONAL GUIDANCE. EACH CROSS MEMBER WILL BE INSTALLED WITH THE ENDS ATTACHED AS NEARLY AS POSSIBLE IN "MATED" POSITIONS (AT EQUAL HEIGHTS, AND AT EQUAL DISTANCES FROM THE END OF THE CONTAINER). CROSS MEMBERS IN EMPTY CONTAINERS AND THOSE NOT USED IN LOADED CONTAINERS MUST BE FASTENED INTO BELT RAILS FOR SHIPMENT. COMPONENTS ASSIGNED TO EACH CONTAINER MUST REMAIN THEREWITH EVEN THOUGH UNUSED DURING SOME SHIPMENTS. THE LOAD BLOCKING COMPONENT DESIGNATED AS "CROSS MEMBER" HEREIN IS IDENTIFIED AS "BEAM ASSEMBLY" WITHIN TM 55-8115-200-23&P, DATED DECEMBER 1979. THE BEAM ASSEMBLY IS FURTHER IDENTIFIED AS NSN 8115-00-165-6623.
- E. DUNNAGE LUMBER SPECIFIED IS OF A NOMINAL SIZE. FOR EXAMPLE, 1" X 4" MATERIAL IS ACTUALLY 3/4" THICK BY 3-1/2" WIDE AND 2" X 6" MATERIAL IS ACTUALLY 1-1/2" THICK BY 5-1/2" WIDE.
- F. CAUTION: DO NOT NAIL DUNNAGE MATERIAL TO THE MILVAN WALLS OR FLOOR. ALL NAILING WILL BE WITHIN THE DUNNAGE.
- G. A STAGGERED NAILING PATTERN WILL BE USED WHENEVER POSSIBLE WHEN NAILS ARE DRIVEN INTO JOINTS OF DUNNAGE ASSEMBLIES OR WHEN LAMINATING DUNNAGE. ADDITIONALLY, THE NAILING PATTERN FOR AN UPPER PIECE OF LAMINATED DUNNAGE WILL BE ADJUSTED AS REQUIRED SO THAT A NAIL FOR THAT PIECE WILL NOT BE DRIVEN THROUGH, ONTO OR RIGHT BESIDE A NAIL IN A LOWER PIECE.
- H. PORTIONS OF THE MILVAN DEPICTED WITHIN THIS DRAWING, SUCH AS ONE OF THE SIDEWALLS, HAVE NOT BEEN SHOWN IN THE LOAD VIEWS FOR CLARITY PURPOSES.
- J. CONVERSION TO METRIC EQUIVALENTS: DIMENSIONS WITHIN THIS DOCUMENT ARE EXPRESSED IN INCHES, AND WEIGHTS ARE EXPRESSED IN POUNDS. WHEN NECESSARY, THE METRIC EQUIVALENTS MAY BE COMPUTED ON THE BASIS OF ONE INCH EQUALS 25.4MM AND ONE POUND EQUALS 0.454 KG.

REVISION

REVISION NO. 1, DATED NOVEMBER 2006, CONSISTS OF:
ADDING REFERENCE TO BSU-88 AND BSG-92 TO THE DRAWING.

(CONTINUED AT LEFT)

FILL MATERIAL, 1" X 4" OR 2" X 4" MATERIAL BY CONTAINER WIDTH MINUS 1" (AS REQD).

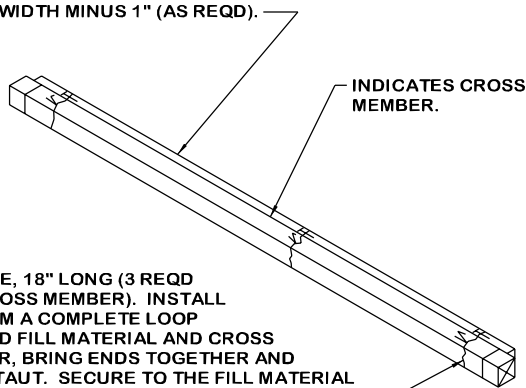

TIE WIRE, 18" LONG (3 REQD PER CROSS MEMBER). INSTALL TO FORM A COMPLETE LOOP AROUND FILL MATERIAL AND CROSS MEMBER, BRING ENDS TOGETHER AND TWIST TAUT. SECURE TO THE FILL MATERIAL WITH A PARTIALLY DRIVEN 10d NAIL BENT OVER THE WIRE, OR WITH A STRAP STAPLE.

FILL DETAIL

MATERIAL SPECIFICATIONS

- LUMBER - - - - -: SEE TM 743-200-1 (DUNNAGE LUMBER) AND VOLUNTARY PRODUCT STANDARD PS 20.
- NAILS - - - - -: ASTM F1667; COMMON STEEL NAIL (NLCMS OR NLCMMS).
- PLYWOOD - - - - -: COMMERCIAL ITEM DESCRIPTION A-A-55057; INDUSTRIAL PLYWOOD, INTERIOR WITH EXTERIOR GLUE, GRADE C-D. IF SPECIFIED GRADE IS NOT AVAILABLE, A BETTER INTERIOR OR AN EXTERIOR GRADE MAY BE SUBSTITUTED.
- ANTI-CHAFING MATERIAL - - - - -: MIL-B-121 (OR EQUAL); NEUTRAL BARRIER MATERIAL.
- WIRE, CARBON STEEL -: ASTM D853; ANNEALED AT FINISH, BLACK OXIDE FINISH, 0.0800" DIA, GRADE 1006 OR BETTER.

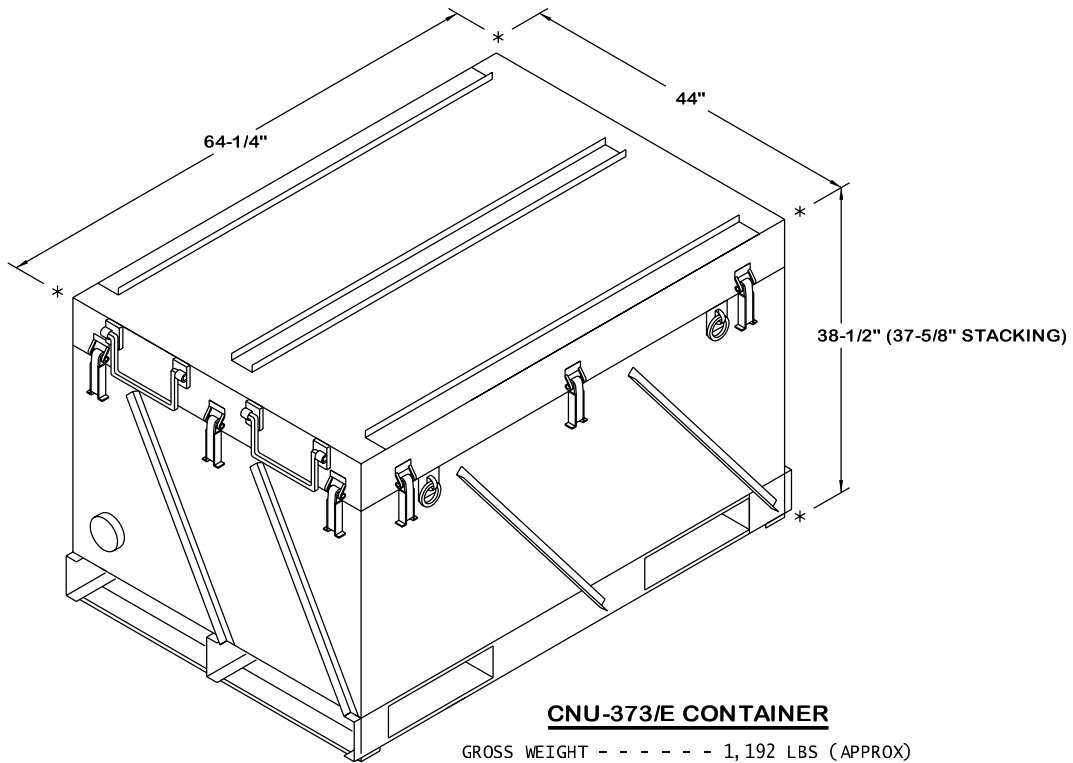

VERTICAL PIECE, 2" X 4" X INSIDE CONTAINER
 HEIGHT MINUS 39-1/2" (TWO HIGH LOAD) OR 1"
 (ONE HIGH LOAD) (REF: 44-1/2" OR 7'-3") (2 REQD).

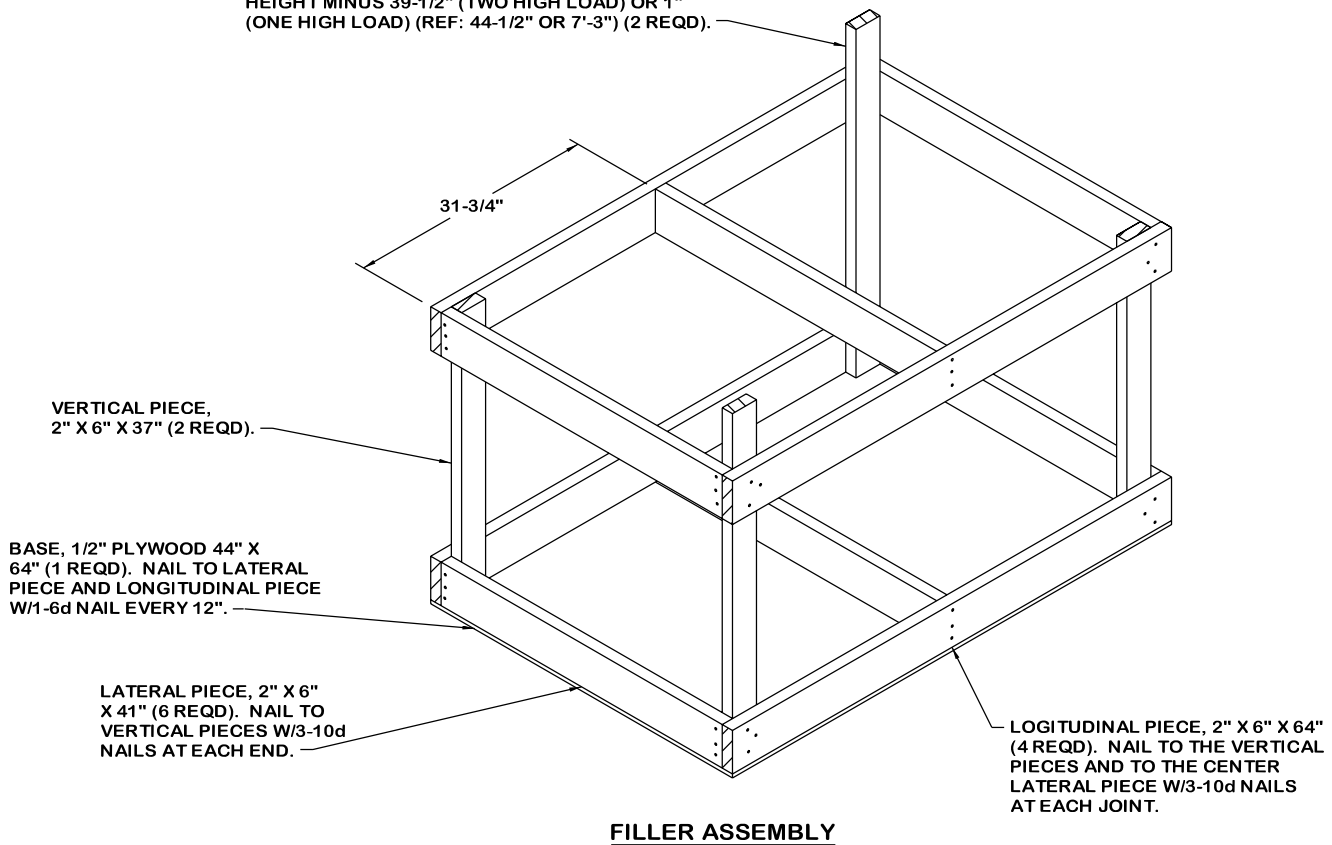

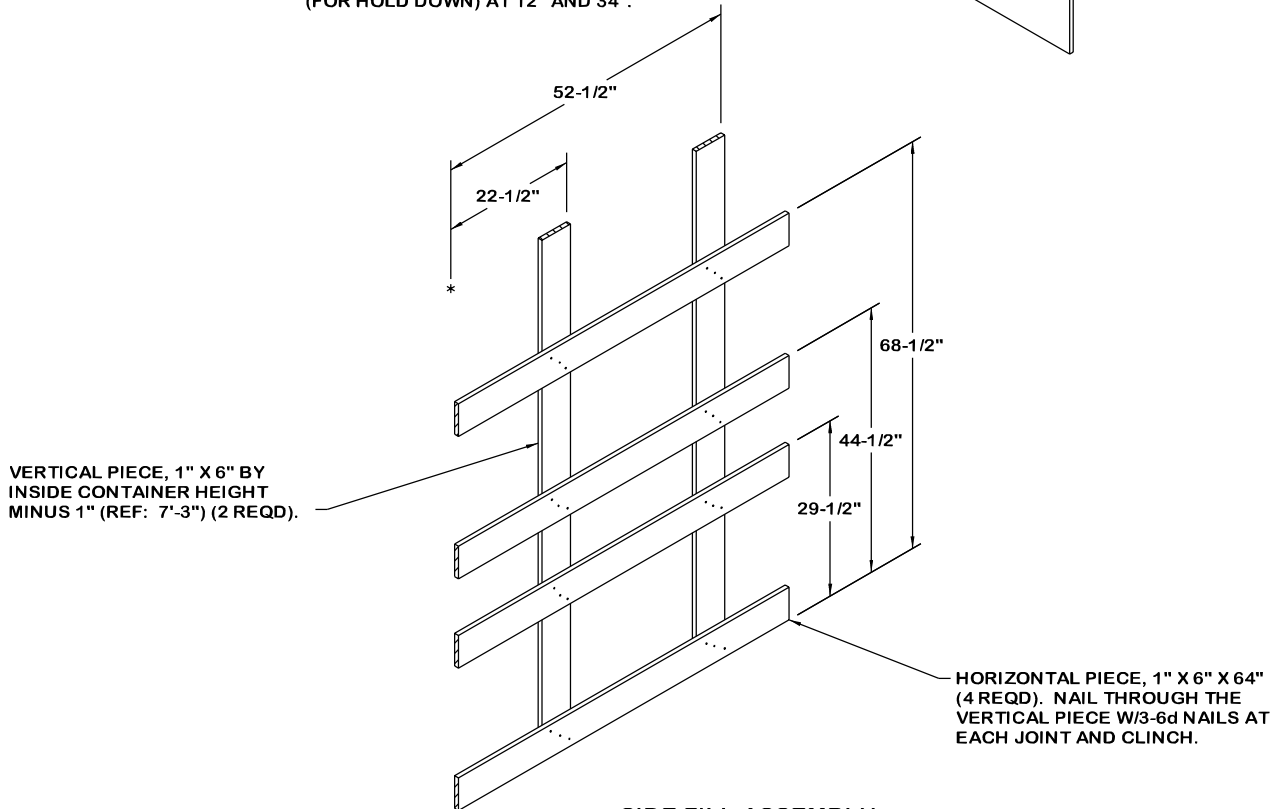
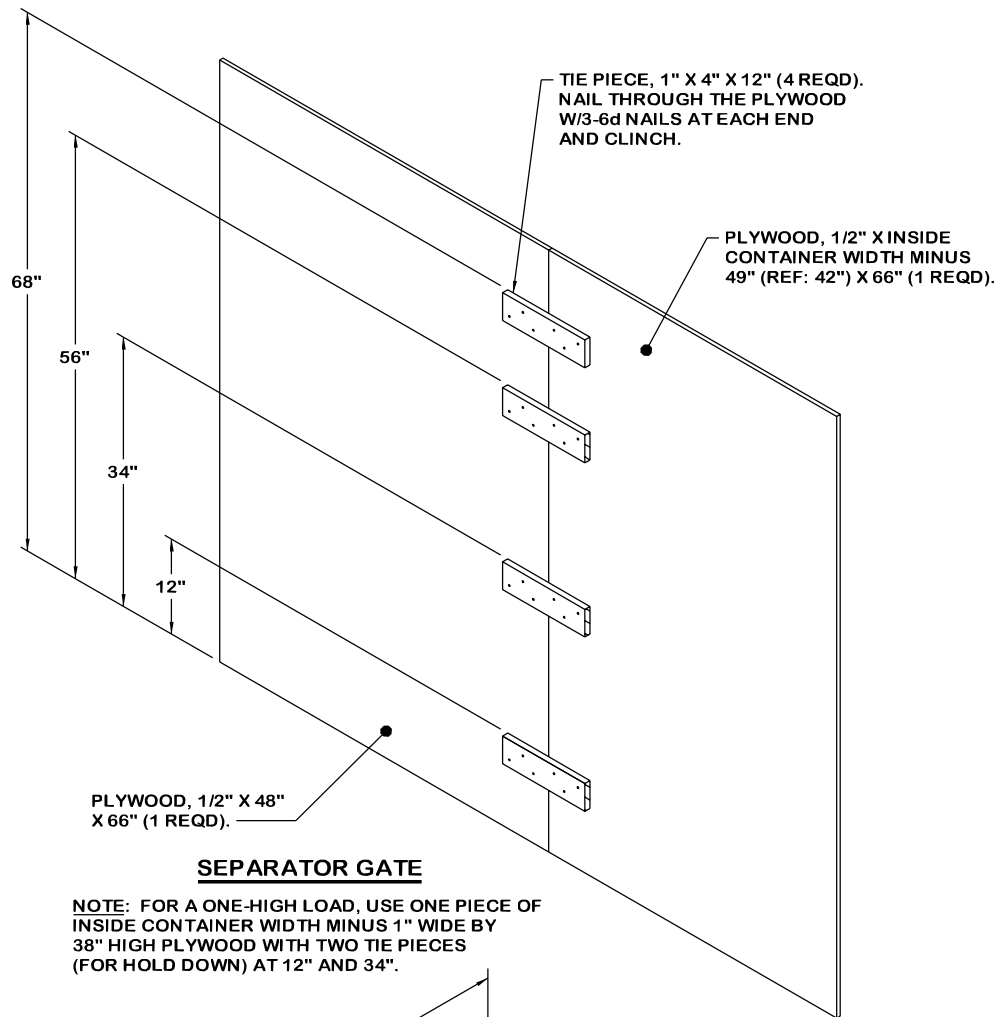

FILLER ASSEMBLY, SEE
PAGE 4 FOR DETAILS.

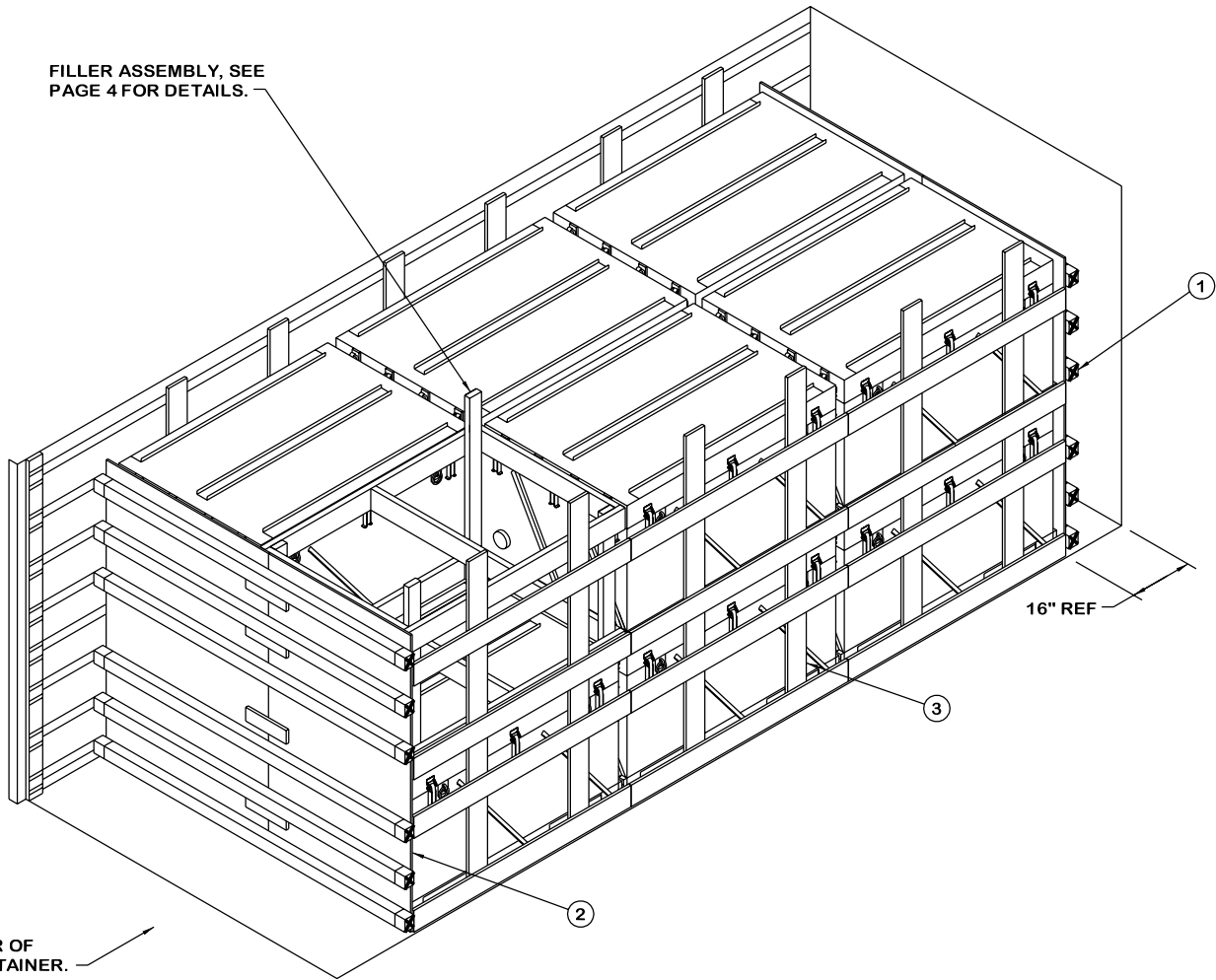

REAR OF
CONTAINER.

LESS-THAN-FULL-LOAD PROCEDURE

KEY NUMBERS REFER TO KEY NUMBERS ON PAGE 2.
SEE GENERAL NOTE "O" ON PAGE 3.