

APPROVED BY
BUREAU OF EXPLOSIVES

dan healy Digitally signed by dan healy
DN: cn=dan healy, o, ou,
email=dan_healy@aar.com,
c=US
Date: 2011.07.06 09:21:44 -05'00'

LOADING AND BRACING* IN MILVAN[⊕] CONTAINERS OF HARPOON MISSILES (AGM-84 OR ATM-84) PACKED IN MK607 MOD 0 CONTAINERS

INDEX

| ITEM | PAGE(S) |
|-----------------------------------------------------|---------|
| FOUR UNIT LOAD - - - - - | 2 |
| GENERAL NOTES AND MATERIAL SPECIFICATIONS - - - - - | 3 |
| CONTAINER DETAILS - - - - - | 4 |
| DETAILS - - - - - | 4-5 |
| LESS-THAN-FULL-LOAD DETAILS - - - - - | 6-7 |
| DETAILS - - - - - | 7-8 |

*THE PROCEDURES SHOWN HEREIN ARE APPLICABLE TO LOADS THAT ARE TO BE SHIPPED BY CONTAINER-ON-FLATCAR (COFC) RAIL, MOTOR, OR WATER CARRIERS.

⊕ONLY MILVAN CONTAINERS WHICH HAVE BEEN MODIFIED TO INCLUDE A MECHANICAL LOAD-BRACING SYSTEM AS SPECIFIED WITHIN MIL-C-52661 WILL BE USED FOR THE MOVEMENT OF AMMUNITION BY T/COFC SERVICE.

DISTRIBUTION STATEMENT A:

APPROVED FOR PUBLIC RELEASE
DISTRIBUTION IS UNLIMITED.

U.S. ARMY MATERIEL COMMAND DRAWING

| | | | | | |
|-------------------------------------------------------------------------------------------------------------------------------------------------------------------------------------------------------------------------------------------------------------------------------------------------------------------------------------|--|------------------------------------------------------------------------------------------------------------------------------------------|------------------------------------------------------------------------------------------------------------------------------------------------------------------------------------------------------------------------------------------------------|------------------|----------|
| APPROVED, U.S. ARMY JOINT MUNITIONS COMMAND RUS.ALLEN.J .1230354282 <small>Digitally signed by RUS.ALLEN.J.1230354282 DN: cn=US, ou=U.S. Government, ou=DoD, ou=PKI, ou=USA, c=RUS.ALLEN.J.1230354282 Date: 2011.08.05 08:08:34 -05'00'</small> | | CAUTION: VERIFY PRIOR TO USE AT WWW.DAC.ARMY.MIL THAT THIS IS THE MOST CURRENT VERSION OF THIS DOCUMENT. THIS IS PAGE 1 OF 8. | | | |
| | | DO NOT SCALE | | JULY 2011 | |
| | | ENGINEER OR TECHNICIAN | BASIC REV. | RICHARD GARSIDE | |
| APPROVED BY ORDER OF COMMANDING GENERAL, U.S. ARMY MATERIEL COMMAND CARNEY.GARY.BURTON.1038708038 <small>Digitally signed by CARNEY.GARY.BURTON.1038708038 DN: cn=US, ou=U.S. Government, ou=DoD, ou=PKI, ou=USA, c=CARNEY.GARY.BURTON.1038708038 Date: 2011.08.15 07:43:54 -05'00'</small> | | TRANSPORTATION ENGINEERING DIVISION | FIEFFER.LAURA .A.1230375727 <small>Digitally signed by FIEFFER.LAURA.A.1230375727 DN: cn=US, ou=U.S. Government, ou=DoD, ou=PKI, ou=USA, c=FIEFFER.LAURA.A.1230375727 Date: 2011.06.23 15:32:03 -05'00'</small> | TESTED | |
| | | VALIDATION ENGINEERING DIVISION | BARICKMAN. PHILIP.W.123 0202202 <small>Digitally signed by BARICKMAN.PHILIP.W.123020202 DN: cn=US, ou=U.S. Government, ou=DoD, ou=PKI, ou=USA, c=BARICKMAN.PHILIP.W.123020202 Date: 2011.06.24 10:19:01 -05'00'</small> | CLASS | DIVISION |
| U.S. ARMY DEFENSE AMMUNITION CENTER | | ENGINEERING DIRECTORATE | BEAVER.JERRY W.1230949952 <small>Digitally signed by BEAVER.JERRY.W.1230949952 DN: cn=US, ou=U.S. Government, ou=DoD, ou=PKI, ou=USA, c=BEAVER.JERRY.W.1230949952 Date: 2011.06.24 11:04:19 -05'00'</small> | 19 | 48 |
| | | | | DRAWING | FILE |
| | | | | 8656 | SP15J91 |

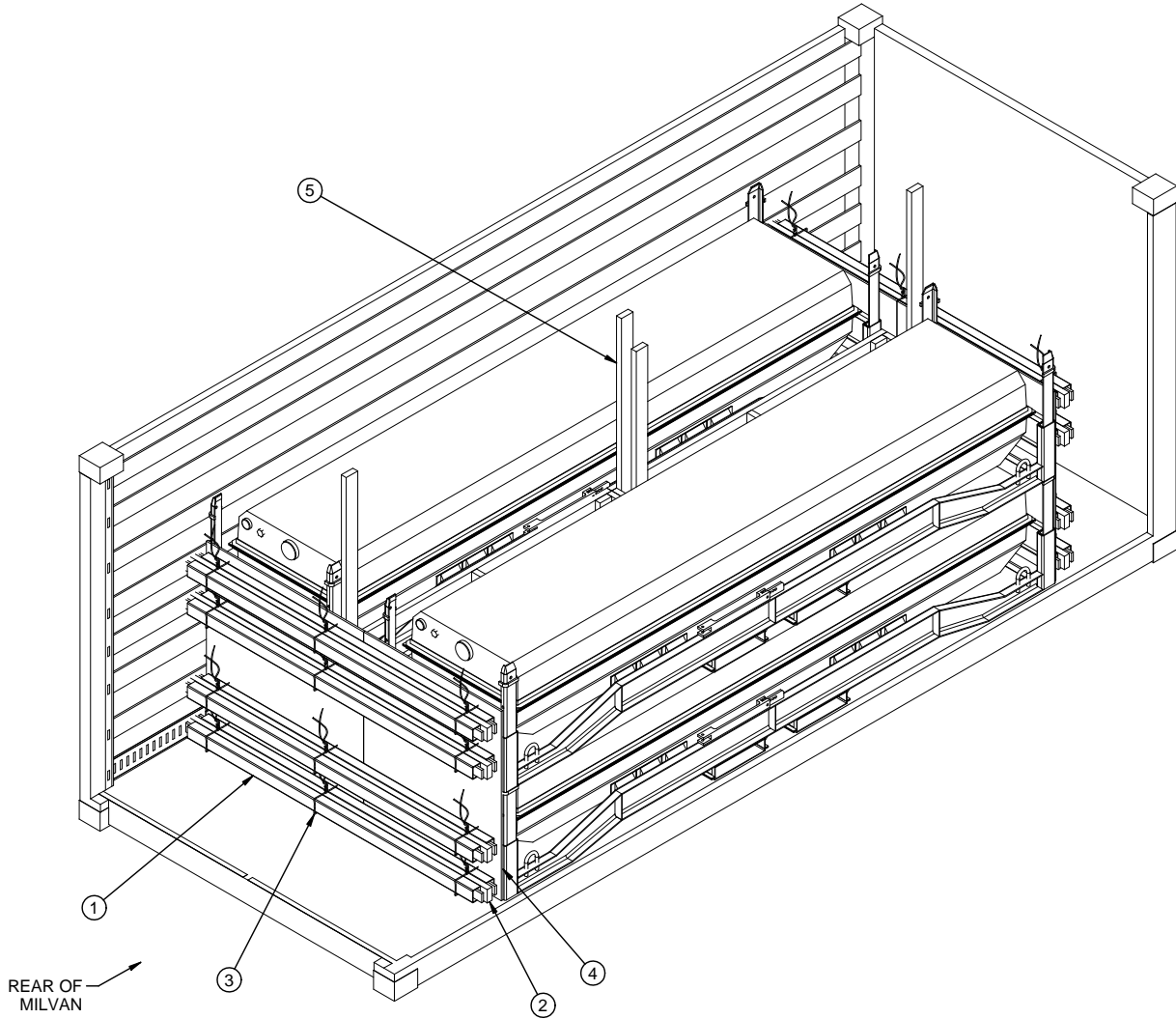

ISOMETRIC VIEW

KEY NUMBERS

- ① CROSSMEMBER (16 REQD). POSITION AS SHOWN IN THE DETAIL ABOVE, AT THE 5", 16", 38" AND 48" HEIGHTS.
- ② FILL MATERIAL, 1" X 4" OR 2" X 4" BY CONTAINER WIDTH MINUS 1" (AS REQD). SEE "FILL DETAIL" ON PAGE 8.
- ③ TIE WIRE, 0.0800" DIAMETER WIRE BY 24" LONG (24 REQD). INSTALL TO FORM A COMPLETE LOOP AROUND FILL MATERIAL AND CROSSMEMBERS, BRING ENDS TOGETHER AND TWIST TAUT. SECURE TO THE FILL MATERIAL WITH A PARTIALLY DRIVEN 10d NAIL BENT OVER THE WIRE, OR WITH A STRAP STAPLE.
- ④ LOAD BEARING GATE (2 REQD). SEE THE DETAIL ON PAGE 5.
- ⑤ CENTER BLOCKING ASSEMBLY (2 REQD). SEE THE DETAIL ON PAGE 4.

| BILL OF MATERIAL | | |
|------------------------------|---------------------------|------------|
| LUMBER | LINEAR FEET | BOARD FEET |
| 1" X 4" | 6 | 2 |
| 2" X 4" | 240 | 160 |
| NAI LS | NO. REQD | POUNDS |
| 6d (2") | 36 | 1/4 |
| 10d (3") | 160 | 2-1/2 |
| PLYWOOD, 1/2" - - - | 62.5 SQ FT REQD - - - - - | 86 LBS |
| WI RE, 0.0800" DIA - - - - - | 48' REQD - - - - - | 1 LB |
| CROSS MEMBER - - - - - | | 16 REQD |

LOAD AS SHOWN

| ITEM | QUANTITY | WEIGHT (APPROX) |
|------------------------|-------------|-----------------|
| MK607 - - - - - | 4 - - - - - | 13, 556 LBS |
| DUNNAGE - - - - - | | 414 LBS |
| CONTAINER - - - - - | | 5, 700 LBS |
| TOTAL WEIGHT - - - - - | | 19, 670 LBS |

GENERAL NOTES

- A. THIS DOCUMENT HAS BEEN PREPARED AND ISSUED IN ACCORDANCE WITH AR 740-1 AND AUGMENTS TM 743-200-1 (CHAPTER 5).
- B. THE SPECIFIED OUTLOADING PROCEDURES ARE APPLICABLE TO LOADS OF HARPOON MISSILES PACKED IN MK607 MOD 0 CONTAINERS. SUBSEQUENT REFERENCE TO CONTAINER HEREIN MEANS CONTAINER WITH MISSILE INSTALLED. SEE PAGE 4 AND NAVAL SEA SYSTEMS COMMAND DRAWING DL2645309 FOR DETAILS OF THE CONTAINER. **CAUTION:** REGARDLESS OF THE QUANTITY OF CONTAINERS TO BE SHIPPED, THE "MAXIMUM GROSS WEIGHT" OF THE MILVAN MUST NOT BE EXCEEDED.
- C. THE LOAD AS SHOWN IS BASED ON A 20' LONG BY 8' WIDE BY 8' HIGH MILVAN WITH INSIDE DIMENSIONS OF 19'-4" LONG BY 92" WIDE BY 87" HIGH. THE LOAD IS DESIGNED FOR TRAILER/CONTAINER-ON-FLATCAR (T/COFC) SHIPMENT.
- D. THE SPECIFIED OUTLOADING PROCEDURES ARE FOR CONTAINERS EQUIPPED WITH SELF-CONTAINED MECHANICAL BRACING DEVICES AS DESCRIBED IN MIL-C-52661. CROSS MEMBER ATTACHMENT FACILITIES WITHIN THESE CONTAINERS MUST PROVIDE FOR THE INSTALLATION OF LOAD BLOCKING CROSS MEMBERS AT THE HEIGHTS SPECIFIED. VOIDS LENGTHWISE WITHIN THE LOADS MUST BE HELD TO A MINIMUM. CROSS MEMBERS MUST BE PLACED AGAINST THE LADING AS TIGHTLY AS THE HOLE SPACING IN THE CROSS MEMBER ATTACHMENT FACILITY PERMITS. SEE THE "FILL DETAIL" ON PAGE 8 FOR ADDITIONAL GUIDANCE. EACH CROSS MEMBER WILL BE INSTALLED WITH THE ENDS ATTACHED AS NEARLY AS POSSIBLE IN "MATED" POSITIONS (AT EQUAL HEIGHTS, AND AT EQUAL DISTANCES FROM THE END OF THE CONTAINER). CROSS MEMBERS IN EMPTY CONTAINERS AND THOSE NOT USED IN LOADED CONTAINERS MUST BE FASTENED INTO BELT RAILS FOR SHIPMENT. COMPONENTS ASSIGNED TO EACH CONTAINER MUST REMAIN THEREWITH EVEN THOUGH UNUSED DURING SOME SHIPMENTS. THE LOAD BLOCKING COMPONENT DESIGNATED AS "CROSS MEMBER" HEREIN IS IDENTIFIED AS "BEAM ASSEMBLY" WITHIN TM 55-8115-200-23&P, DATED DECEMBER 1979. THE BEAM ASSEMBLY IS FURTHER IDENTIFIED AS NSN 8115-00-165-6623.
- E. WHEN LOADING CONTAINERS, THEY ARE TO BE POSITIONED SO AS TO ACHIEVE A TIGHT LOAD (TIGHT AGAINST THE DUNNAGE ASSEMBLIES). THE UNLOCKED SPACE ACROSS THE WIDTH OF A LOAD BAY IS NOT TO EXCEED 1-1/2". EXCESSIVE SLACK CAN BE ELIMINATED FROM A LOAD BY LAMINATING ADDITIONAL PIECES OF APPROPRIATE THICKNESS TO THE HORIZONTAL PIECES ON THE CENTER BLOCKING ASSEMBLIES. NAIL EACH ADDITIONAL PIECE W/1 APPROPRIATELY SIZED NAIL EVERY 12". ADDITIONALLY, THE LENGTH OF THE STRUTS IN THE CENTER BLOCKING ASSEMBLIES MAY BE ADJUSTED AS REQUIRED TO FACILITATE VARIANCE IN THE SIZE OF THE CONTAINERS.
- F. DUNNAGE LUMBER SPECIFIED IS OF NOMINAL SIZE. FOR EXAMPLE, 1" X 4" MATERIAL IS ACTUALLY 3/4" THICK BY 3-1/2" WIDE AND 2" X 6" MATERIAL IS ACTUALLY 1-1/2" THICK BY 5-1/2" WIDE.
- G. A STAGGERED NAILING PATTERN WILL BE USED WHENEVER POSSIBLE WHEN NAILS ARE DRIVEN INTO JOINTS OF DUNNAGE ASSEMBLIES OR WHEN LAMINATING DUNNAGE. ADDITIONALLY, THE NAILING PATTERN FOR AN UPPER PIECE OF LAMINATED DUNNAGE WILL BE ADJUSTED AS REQUIRED SO THAT A NAIL FOR THAT PIECE WILL NOT BE DRIVEN THROUGH, ON TO, OR RIGHT BESIDE A NAIL IN A LOWER PIECE.
- H. **CAUTION:** DO NOT NAIL DUNNAGE MATERIAL TO THE MILVAN WALLS OR FLOOR. ALL NAILING WILL BE WITHIN THE DUNNAGE.
- J. PORTIONS OF THE MILVAN DEPICTED WITHIN THIS DRAWING, SUCH AS ONE OF THE SIDEWALLS, HAVE NOT BEEN SHOWN IN THE LOAD VIEWS FOR CLARITY PURPOSES.
- K. TO MAKE LOADING EASIER, TO HELP ACHIEVE A TIGHT LOAD ACROSS A CONTAINER, AND TO PREVENT UNACCEPTABLE DAMAGE TO LADING UNITS WHEN LOADING A MILVAN, A SLIP-SHEET CAN BE USED EFFECTIVELY AS A "SHOE-HORN" TYPE DEVICE. THE SLIP-SHEET WILL PROVIDE A SMOOTH SURFACE THAT WILL PREVENT CONTAINERS FROM INTERLOCKING OR CATCHING ON OTHER PROJECTIONS WHEN LATERALLY ADJACENT LADING UNITS ARE BEING LOADED. A SLIP-SHEET WILL BE USED AFTER ONE-HALF OF A STACK IS LOADED WITH ITS SIDES IN TIGHT CONTACT AT THE SIDES OF THE MILVAN. THE SLIP-SHEETS ARE TO BE PLACED AGAINST THE OTHER SIDES OF THE STACK BEFORE THE OTHER HALF OF THE STACK IS LOADED. AFTER A STACK IS COMPLETED, THE SLIP-SHEETS ARE TO BE REMOVED. A SLIP-SHEET OF SUITABLE SIZE CAN BE MADE FROM A SHEET OF 1/8" TEMPERED HARDBOARD (MASONITE) OR FROM A SHEET OF ANY OTHER MATERIAL THAT WILL SATISFY THE REQUIREMENTS.
- L. THE MAXIMUM LOAD WEIGHTS ARE CONTROLLED BY EQUIPMENT CAPABILITY FACTORS. ALTHOUGH THE HEAVIEST MAXIMUM LOADS ARE DELINEATED IN THE LOAD VIEWS, PROVISIONS ARE INCLUDED WITHIN THIS DRAWING SO THAT THE BASIC LOADS CAN BE ADJUSTED TO SATISFY A LESSER QUANTITY OF LADING UNITS. DEPENDING ON TRANSPORTATION ROUTING, IT MAY BE NECESSARY TO REDUCE THE LOAD WEIGHT TO SATISFY "WEIGHT LAWS" OF CERTAIN STATES. ALSO, IT MAY BE NECESSARY TO REDUCE THE LOAD WEIGHT TO SATISFY OTHER WEIGHT RESTRICTIONS IMPOSED ON THE INTERMODAL CONTAINER SYSTEM.

(CONTINUED AT RIGHT)

(GENERAL NOTES CONTINUED)

- M. REQUIREMENTS CITED WITHIN THE ASSOCIATION OF AMERICAN RAILROADS (AAR) INTERMODAL LOADING GUIDE APPLY WHEN THE SHIPMENT MOVES BY TRAILER/CONTAINER-ON-FLATCAR (T/COFC). SPECIAL T/COFC NOTES FOLLOW:
1. A LOADED CONTAINER MUST BE ON A CHASSIS EQUIPPED WITH TWO BOGIE ASSEMBLIES WHEN BEING MOVED IN TOFC SERVICE, REGARDLESS OF THE LOAD WEIGHT WITHIN THE CONTAINER.
 2. LOAD LIMITS OF T/COFC RAIL CARS MUST NOT BE EXCEEDED, NOR WILL A CAR BE LOADED SO THAT THE TRUCK UNDER ONE END OF THE CAR CARRIES MORE THAN ONE-HALF OF THE LOAD LIMIT FOR THAT CAR.
 3. CHASSIS/CONTAINERS COUPLED INTO A 40-FOOT TRAILER CONFIGURATION MUST BE PLACED AT THE B-END OF A TOFC RAIL CAR. THE REAR END OF THE 40-FOOT UNIT WILL OVERHANG THE END OF THE CAR IF IT IS PLACED AT THE A-END. TWENTY-FOOT AND 40-FOOT UNITS CAN BE LOADED ON THE SAME CAR.
- N. DURING INTRASTATE AND/OR INTERSTATE MOVES BY MOTOR CARRIER, A PROPER CHASSIS OR MODIFIED FLATBED TRAILER MUST BE USED TO PRECLUDE VIOLATION OF ONE OR MORE "WEIGHT LAWS" APPLICABLE TO THE STATE OR STATES INVOLVED.
- O. CONVERSION TO METRIC EQUIVALENTS: DIMENSIONS WITHIN THIS DOCUMENT ARE EXPRESSED IN INCHES AND WEIGHTS ARE EXPRESSED IN POUNDS. WHEN NECESSARY, THE METRIC EQUIVALENTS MAY BE COMPUTED ON THE BASIS OF ONE INCH EQUALS 25.4MM AND ONE POUND EQUALS 0.454 KG.
- P. WHETHER A CONTAINER IS FULL OR IS LOADED WITH A REDUCED QUANTITY OF LADING UNITS, THE LENGTHWISE CENTER OF GRAVITY OF THE LOAD MUST BE WITHIN 12", IN EITHER DIRECTION, OF THE MID-POINT OF THE CONTAINER.
- Q. THE QUANTITY OF CONTAINERS SHOWN IN THE LOAD ON PAGE 2 MAY BE REDUCED FOR SHIPMENT, IF DESIRED. SEE THE DETAILS ON PAGES 6 AND 7.
- R. AS REQUIRED BY THE ASSOCIATION OF AMERICAN RAILROADS (AAR), ALL 1-1/4" AND 2" STEEL STRAPPING USED FOR LOAD RESTRAINT MUST BE MARKED AS SPECIFIED WITHIN THE APPLICABLE AAR RULES GOVERNING LOADING, BLOCKING AND BRACING OF FREIGHT WITHIN THE CONVEYANCE. FOR THE SPECIFIC MARKING SIZE, FREQUENCY, ETC., REQUIRED, REFER TO THE APPROPRIATE AAR LOADING RULES.
- S. ANTI-CHAFING MATERIAL MAY BE INSTALLED AT POINTS OF CONTACT BETWEEN CONTAINERS, BETWEEN CONTAINERS AND MILVAN, AND BETWEEN CONTAINERS AND STEEL STRAPPING, IF DESIRED, TO PREVENT CHAFING DAMAGE TO CONTAINER PAINT AND MARKINGS.
- T. WHEN STEEL STRAPPING IS SEALED AT AN END-OVER-END LAP JOINT, A MINIMUM OF ONE SEAL WITH TWO PAIR OF NOTCHES WILL BE USED TO SEAL THE JOINT WHEN A NOTCH-TYPE SEALER IS BEING USED. A MINIMUM OF TWO SEALS, BUTTED TOGETHER, WITH TWO PAIR OF CRIMPS PER SEAL WILL BE USED TO SEAL THE JOINT WHEN A CRIMP-TYPE SEALER IS BEING USED. REFER TO THE "STRAP JOINT A" AND "STRAP JOINT B" DETAILS ON PAGE 6 FOR GUIDANCE.

MATERIAL SPECIFICATIONS

| | | |
|------------------------------|-----------|----------------------------------------------------------------------------------------------------------------------------------------------------------------------------------------------------|
| <u>LUMBER</u> | - - - - - | SEE TM 743-200-1 (DUNNAGE LUMBER) AND VOLUNTARY PRODUCT STANDARD PS 20. |
| <u>NAILS</u> | - - - - - | ASTM F1667; COMMON STEEL NAIL (NLCMS OR NLCMS). |
| <u>PLYWOOD</u> | - - - - - | COMMERCIAL ITEM DESCRIPTION A-A-55057, INDUSTRIAL PLYWOOD, INTERIOR WITH EXTERIOR GLUE, GRADE C-D. IF SPECIFIED GRADE IS NOT AVAILABLE, A BETTER INTERIOR OR AN EXTERIOR GRADE MAY BE SUBSTITUTED. |
| <u>STRAPPING, STEEL</u> | - - - - - | ASTM D3953; FLAT STRAPPING, TYPE 1, HEAVY DUTY, FINISH A, B (GRADE 2), OR C. |
| <u>SEAL, STRAP</u> | - - - - - | ASTM D3953; CLASS H, FINISH A, B (GRADE 2), OR C, DOUBLE NOTCH TYPE, STYLE I, II, OR IV. |
| <u>WIRE, CARBON STEEL</u> | - - - - - | ASTM A853; ANNEALED AT FINISH, BLACK OXIDE FINISH, 0.0800" DIA, GRADE 1006 OR BETTER. |
| <u>ANTI-CHAFING MATERIAL</u> | - - - - - | MIL-B-121 (OR EQUAL); NEUTRAL BARRIER MATERIAL. |

MK607 CONTAINER

GROSS WEIGHT (MOD 0) - - - - 3,389 LBS (APPROX)
 CUBE - - - - - 120.5 CU FT (APPROX)

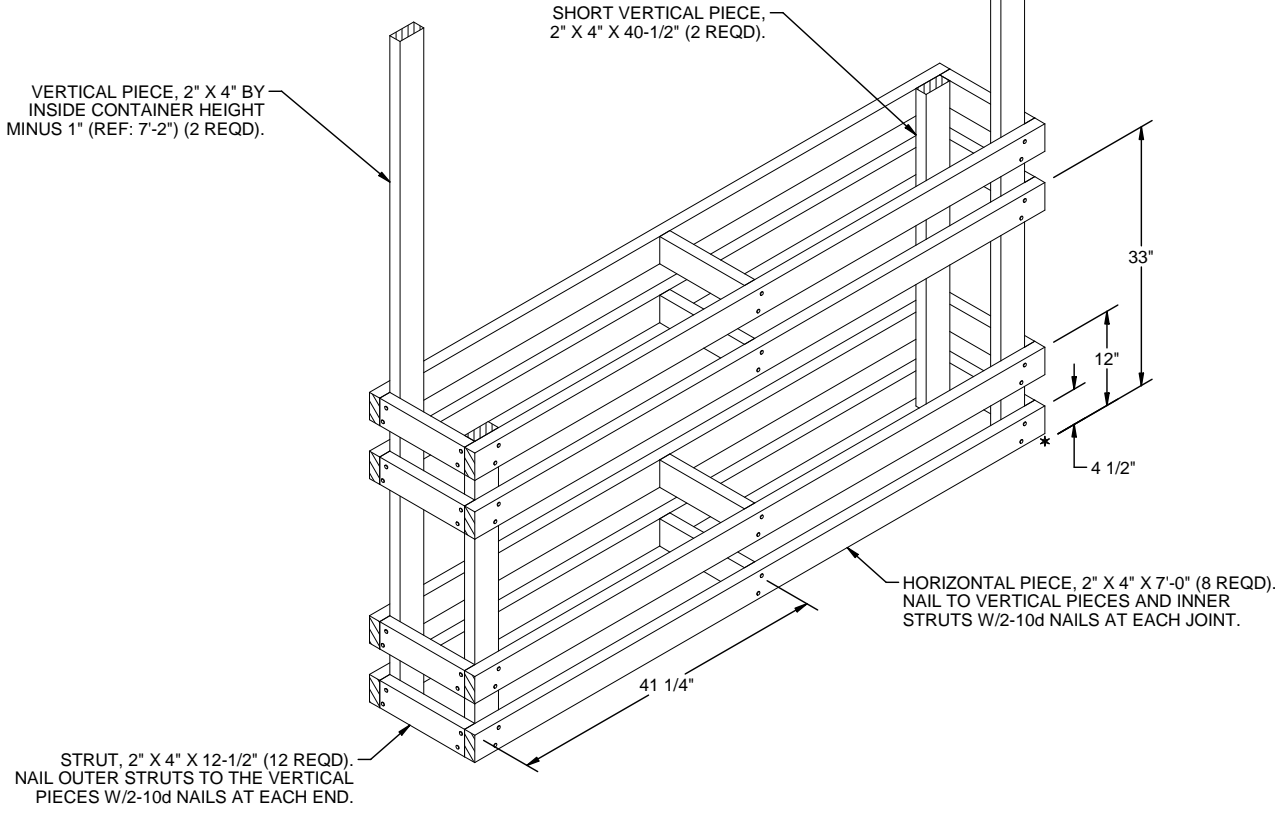
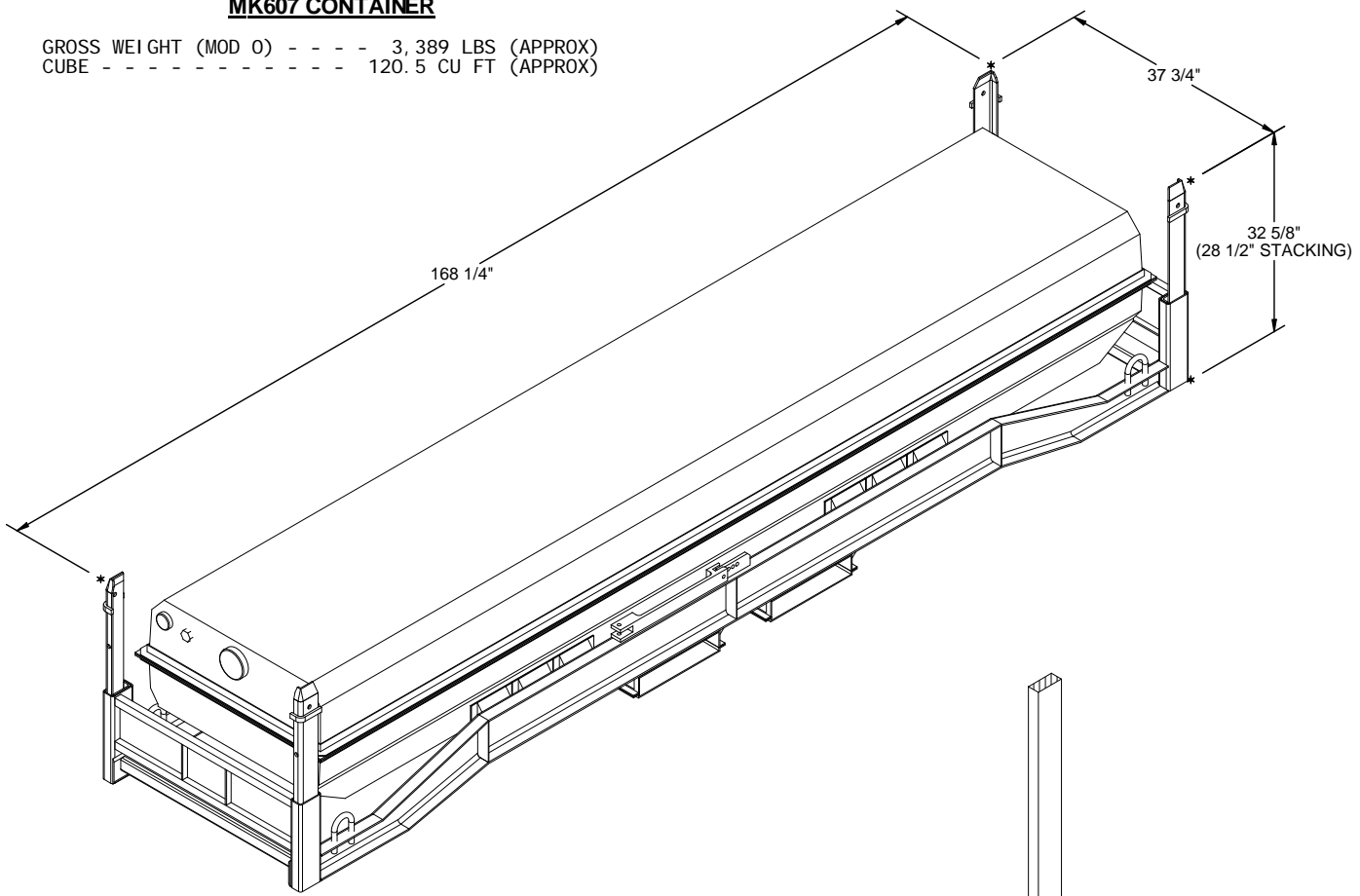

CENTER BLOCKING ASSEMBLY

NOTE: FOR A ONE-HIGH LOAD, ELIMINATE THE TOP FOUR HORIZONTAL PIECES
 AND TOP SIX STRUTS AND MAKE THE SHORT VERTICAL PIECE 13" LONG.

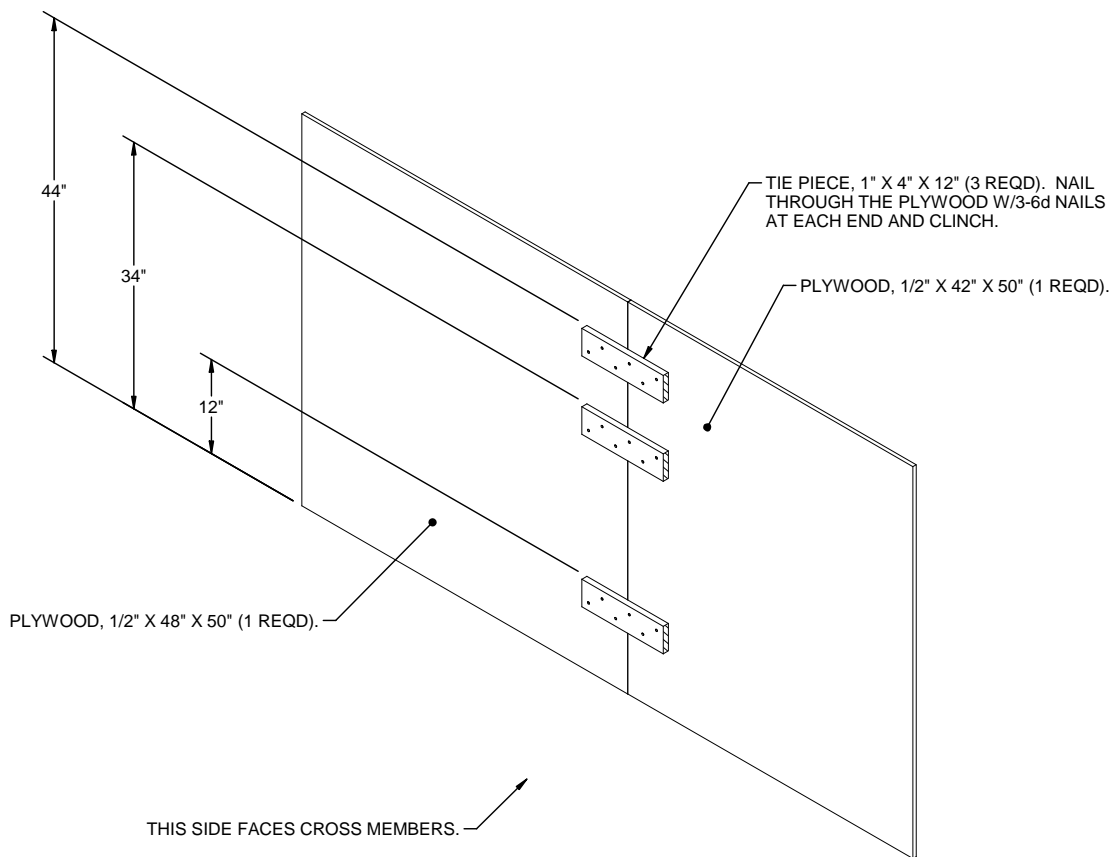

LOAD BEARING GATE

NOTE: FOR A ONE HIGH LOAD, USE ONE PIECE OF PLYWOOD, INSIDE CONTAINER WIDTH MINUS 1" (REF: 7'-7") BY 18". FOR A ONE HIGH/ONE WIDE LOAD, USE ONE PIECE OF PLYWOOD, 37-1/2" X 18". FOR BOTH, USE ONE HOLD-DOWN PIECE, 1" X 4" X 12", CENTERED ACROSS THE WIDTH OF THE PLYWOOD AND LOCATED WITH THE UPPER EDGE AT 12", NAILED THRU THE PLYWOOD W/4-6d NAILS, CLINCHED.

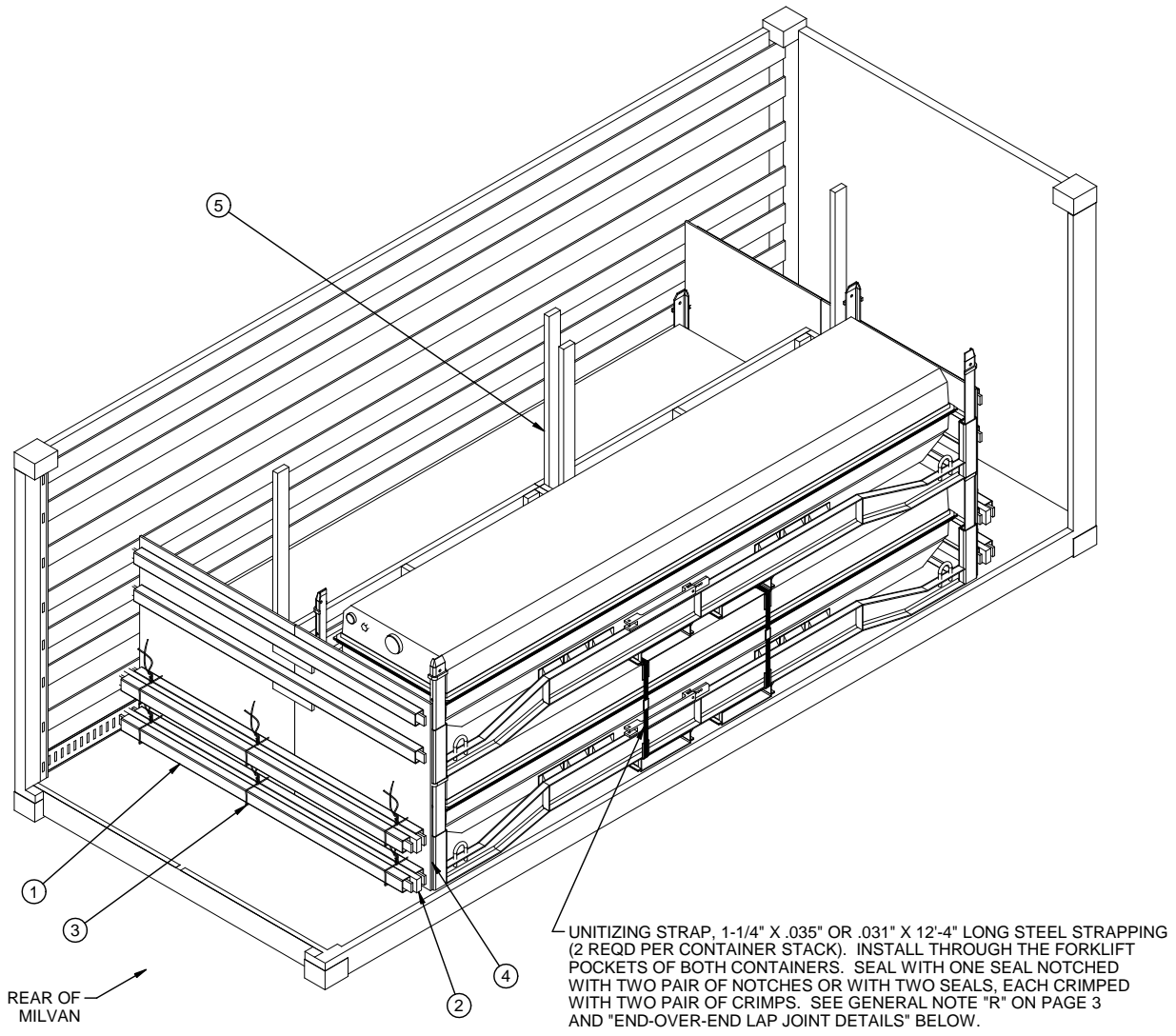

SPECIAL NOTE:

WHEN REDUCING A LOAD BY ONE OR MORE CONTAINERS, IT WILL BE NECESSARY TO UNITIZE THE CONTAINER STACK WHICH IS LATERALLY ADJACENT TO THE OMITTED CONTAINER AS DEPICTED IN THE LOAD VIEW ABOVE. SEE GENERAL NOTE "P" ON PAGE 3.

LESS-THAN-FULL-LOAD PROCEDURE

KEY NUMBERS REFER TO KEY NUMBERS ON PAGE 2.

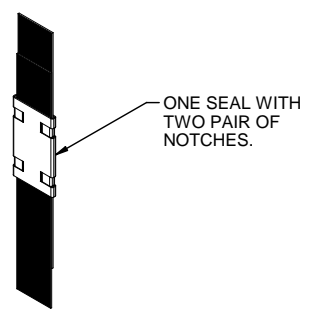

STRAP JOINT A
METHOD OF SECURING A STRAP JOINT WHEN USING A NOTCH-TYPE SEALER.

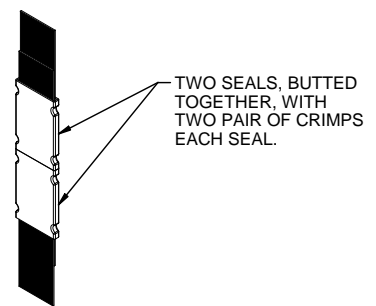

STRAP JOINT B
METHOD OF SECURING A STRAP JOINT WHEN USING A CRIMP-TYPE SEALER.

END-OVER-END LAP JOINT DETAILS

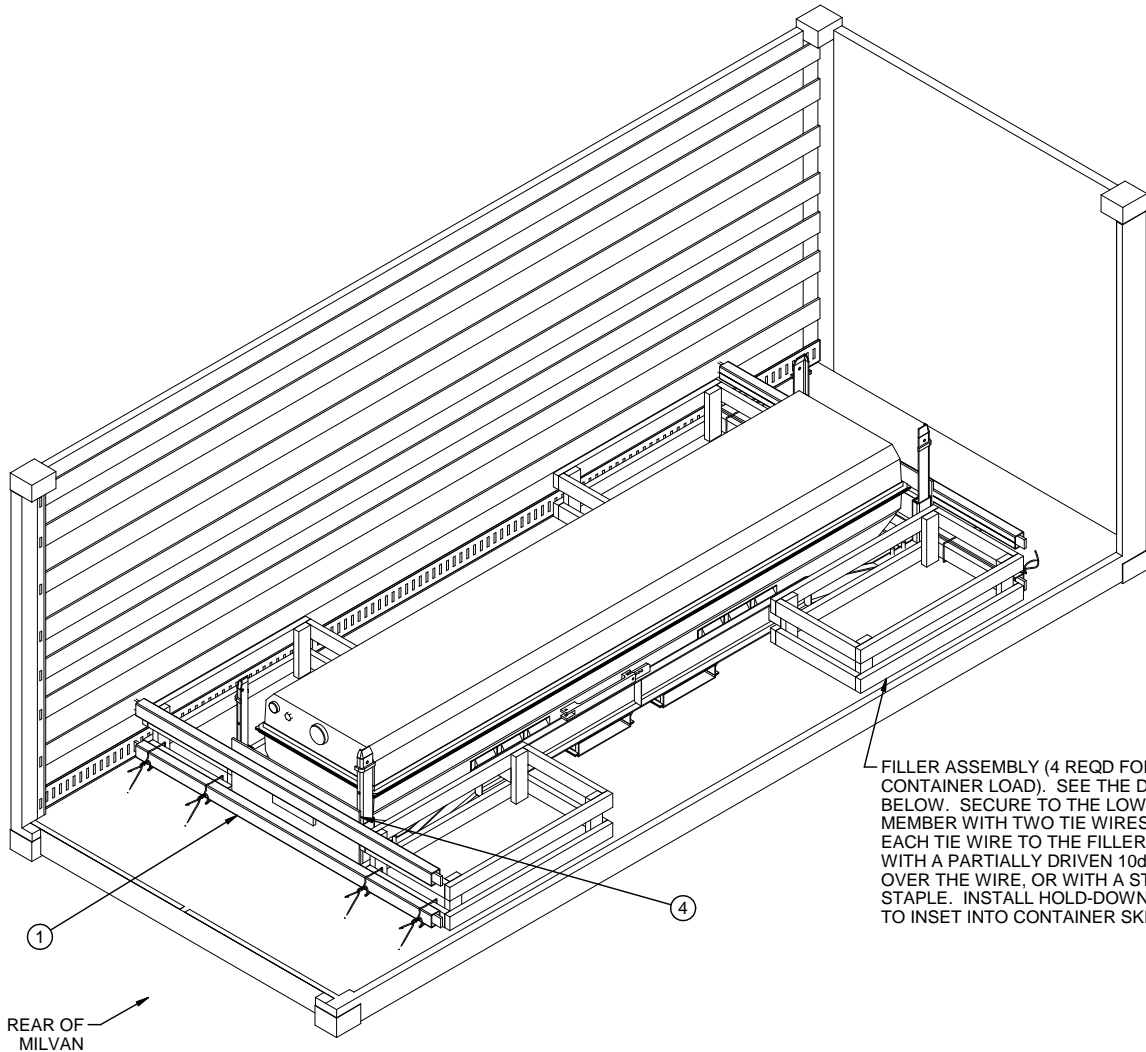

FILLER ASSEMBLY (4 REQD FOR A SINGLE CONTAINER LOAD). SEE THE DETAIL BELOW. SECURE TO THE LOWER CROSS MEMBER WITH TWO TIE WIRES. SECURE EACH TIE WIRE TO THE FILLER ASSEMBLY WITH A PARTIALLY DRIVEN 10d NAIL BENT OVER THE WIRE, OR WITH A STRAP STAPLE. INSTALL HOLD-DOWN PIECE TO INSET INTO CONTAINER SKID.

REAR OF MILVAN

LESS-THAN-FULL-LOAD PROCEDURE

KEY NUMBERS REFER TO KEY NUMBERS ON PAGE 2.

CROSS MEMBERS NEED NOT BE DOUBLED WHEN SHIPPING ONE CONTAINER. A TOTAL OF FOUR CROSS MEMBERS ARE REQUIRED, AS DEPICTED ABOVE.

VERTICAL PIECE, 2" X 4" X 12" (4 REQD).

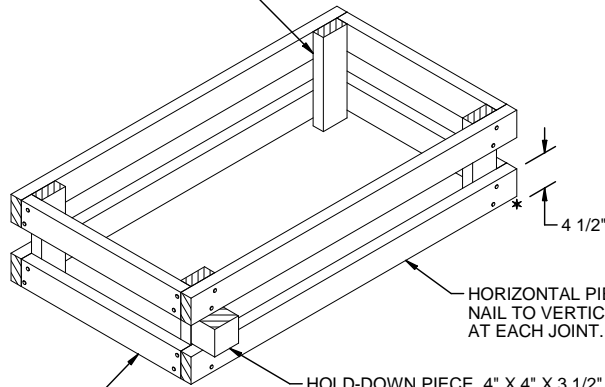

HORIZONTAL PIECE, 2" X 4" X 48" (4 REQD). NAIL TO VERTICAL PIECES W/2-10d NAILS AT EACH JOINT.

STRUT, 2" X 4" X 23 1/2" (4 REQD). NAIL TO THE VERTICAL PIECES W/2-10d NAILS AT EACH END.

HOLD-DOWN PIECE, 4" X 4" X 3 1/2" (1 REQD). NAIL THRU THE VERTICAL PIECE INTO THE HOLD-DOWN PIECE W/2-10d NAILS AFTER PLACEMENT OF FILLER ASSEMBLY INTO LOAD.

FILLER ASSEMBLY

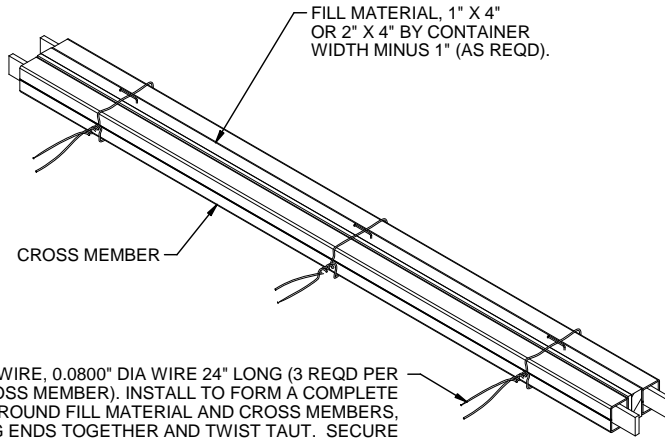

FILL MATERIAL, 1" X 4"
OR 2" X 4" BY CONTAINER
WIDTH MINUS 1" (AS REQD).

CROSS MEMBER

TIE WIRE, 0.0800" DIA WIRE 24" LONG (3 REQD PER
CROSS MEMBER). INSTALL TO FORM A COMPLETE
LOOP AROUND FILL MATERIAL AND CROSS MEMBERS,
BRING ENDS TOGETHER AND TWIST TAUT. SECURE
TO FILL MATERIAL WITH A PARTIALLY DRIVEN 10d
NAIL BENT OVER THE WIRE, OR WITH A STRAP STAPLE.

FILL DETAIL

THIS DETAIL DEPICTS THE METHOD OF POSITIONING FILL
MATERIAL BETWEEN CROSS MEMBERS WHEN DOUBLED
CROSS MEMBERS ARE REQUIRED.

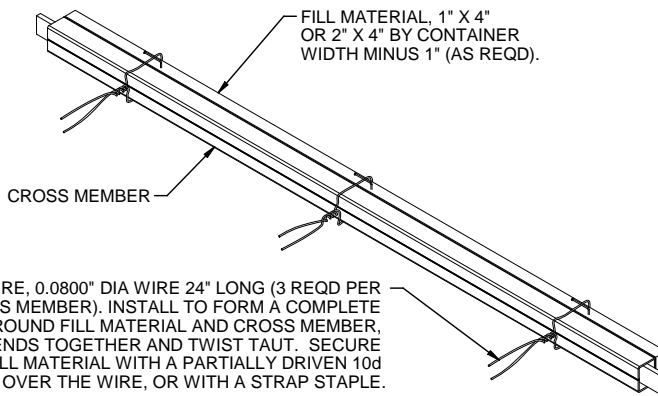

FILL MATERIAL, 1" X 4"
OR 2" X 4" BY CONTAINER
WIDTH MINUS 1" (AS REQD).

CROSS MEMBER

TIE WIRE, 0.0800" DIA WIRE 24" LONG (3 REQD PER
CROSS MEMBER). INSTALL TO FORM A COMPLETE
LOOP AROUND FILL MATERIAL AND CROSS MEMBER,
BRING ENDS TOGETHER AND TWIST TAUT. SECURE
TO FILL MATERIAL WITH A PARTIALLY DRIVEN 10d
NAIL BENT OVER THE WIRE, OR WITH A STRAP STAPLE.

FILL DETAIL

THIS DETAIL DEPICTS THE METHOD OF POSITIONING FILL
MATERIAL BETWEEN CROSS MEMBERS AND LADING, WHEN
THE VOID BETWEEN THE TWO IS GREATER THAN 1".