

APPROVED BY  
BUREAU OF EXPLOSIVES

*D. M. Healy*

DATE 9-12-97

# LOADING AND BRACING IN END OPENING ISO CONTAINERS OF CONTROL SECTION (SHRIKE), PACKED 1 PER CNU-246/E CONTAINER

## INDEX

ITEM	PAGE(S)
GENERAL NOTES, AND MATERIAL SPECIFICATIONS - - - - -	2
CONTAINER DETAIL - - - - -	3
TYPICAL LOADING PROCEDURES - - - - -	4,5
DETAILS - - - - -	6-8

- LOADING AND BRACING SPECIFICATIONS SET FORTH WITHIN THIS DRAWING ARE APPLICABLE TO LOADS THAT ARE TO BE SHIPPED BY TRAILER/CONTAINER-ON-FLATCAR (T/COFC) RAIL CARRIER SERVICE. THESE SPECIFICATIONS MAY ALSO BE USED FOR LOADS THAT ARE TO BE MOVED BY MOTOR OR WATER CARRIERS.

## U.S. ARMY MATERIEL COMMAND DRAWING

APPROVED, U.S. ARMY INDUSTRIAL OPERATIONS COMMAND  <i>Stanley L. Fine</i>	ENGINEER	BASIC		DO NOT SCALE			
		REV.		WEBSITE: HTTP://WWW.DAC.ARMY.MIL			
	TECHNICIAN	BASIC	RICHARD HAYNES	APRIL 1997			
		REV.					
	DRAFTSMAN	BASIC					
		REV.					
APPROVED BY ORDER OF COMMANDING GENERAL, U.S. ARMY MATERIEL COMMAND  <i>William F. Ernst</i>  DEFENSE AMMUNITION CENTER	TRANSPORTATION ENGINEERING DIVISION		<i>William F. Ernst</i>				
	VALIDATION ENGINEERING DIVISION	TESTED	<i>William F. Ernst</i>	CLASS	DIVISION	DRAWING	FILE
	LOGISTICS ENGINEERING OFFICE		<i>William F. Ernst</i>	19	48	8647	SP15J84

GENERAL NOTES

(GENERAL NOTES CONTINUED)

- A. THIS DOCUMENT HAS BEEN PREPARED AND ISSUED IN ACCORDANCE WITH AR 740-1 AND AUGMENTS TM 743-200-1 (CHAPTER 5).
- B. THE SPECIFIED OUTLOADING PROCEDURES ARE APPLICABLE TO LOADS OF CONTROL SECTION, MK5, MOD 3, (SHRIKE) PACKED ONE (1) PER CNU-246/E CONTAINER. SEE PAGE 3 FOR DETAILS OF THE CNU-246/E CONTAINER. CAUTION: REGARDLESS OF THE NUMBER OF CONTROL SECTION CONTAINERS TO BE SHIPPED, THE "MAXIMUM GROSS WEIGHT" OF THE END OPENING ISO CONTAINER MUST NOT BE EXCEEDED.
- C. THE LOAD AS SHOWN IS BASED ON A 4,700 POUND 20' LONG BY 8' WIDE BY 8'-6" HIGH END OPENING ISO CONTAINER WITH INSIDE DIMENSIONS OF 19'-4" LONG BY 92" WIDE BY 93" HIGH, WITH A MAXIMUM GROSS WEIGHT OF 52,910 POUNDS. OLDER/OTHER CONTAINERS MAY HAVE A TOTAL INSIDE HEIGHT OF 95", BUT A CLEAR HEIGHT UNDER THE ROOF BOWS OF 93". VERIFY INSIDE CONTAINER HEIGHT PRIOR TO FABRICATING DUNNAGE. THE LOAD IS DESIGNED FOR TRAILER/CONTAINER-ON-FLATCAR (T/COFC) SHIPMENT, HOWEVER, THE LOAD AS DESIGNED CAN ALSO BE MOVED BY OTHER SURFACE MODES OF TRANSPORT. NOTICE: OTHER CONTAINERS OF THE SAME DESIGN CONFIGURATION CAN BE USED.
- D. WHEN LOADING CNU-246/E CONTAINERS, THEY ARE TO BE POSITIONED SO AS TO ACHIEVE A TIGHT LOAD (TIGHT AGAINST THE DUNNAGE ASSEMBLIES). THE UNBLOCKED SPACE ACROSS THE WIDTH OF A LOAD BAY IS NOT TO EXCEED 1-1/2". EXCESSIVE SLACK CAN BE ELIMINATED FROM A LOAD BY INCREASING THE WIDTH OF THE SIDE FILL ASSEMBLY AS REQUIRED TO FACILITATE VARIANCE IN THE CONTAINER SIZE.
- E. DUNNAGE LUMBER SPECIFIED IS OF NOMINAL SIZE. FOR EXAMPLE, 1" X 4" MATERIAL IS ACTUALLY 3/4" THICK BY 3-1/2" WIDE AND 2" X 6" MATERIAL IS ACTUALLY 1-1/2" THICK BY 5-1/2" WIDE.
- F. A STAGGERED NAILING PATTERN WILL BE USED WHENEVER POSSIBLE WHEN NAILS ARE DRIVEN INTO JOINTS OF DUNNAGE ASSEMBLIES OR WHEN LAMINATING DUNNAGE. ADDITIONALLY, THE NAILING PATTERN FOR AN UPPER PIECE OF LAMINATED DUNNAGE WILL BE ADJUSTED AS REQUIRED SO THAT A NAIL FOR THAT PIECE WILL NOT BE DRIVEN THROUGH ONTO OR RIGHT BESIDE A NAIL IN A LOWER PIECE.
- G. IN SOME CONTAINERS THERE IS A SLOT AT THE CORNERS OF THE FORWARD WALL. PIECES OF DUNNAGE MATERIAL MUST BE LAMINATED TO THE BUFFER PIECES ON THE FORWARD BLOCKING ASSEMBLY TO PROVIDE A FLAT SURFACE FOR THE BUFFER PIECES. A PIECE OF 2" X 4", 2" X 3" OR A SPECIAL WIDTH PIECE CUT-TO-FIT CAN BE USED. THIS FILL PIECE WILL BE NAILED WITH ONE APPROPRIATELY SIZED NAIL EVERY 12". NOTE THAT SOME CONTAINERS ARE EQUIPPED WITH "TIE-BARS" IN THE CORNER SLOT, WHICH PRECLUDE THE USE OF A FULL HEIGHT FILL PIECE. WHEN "TIE-BARS" ARE PRESENT, THE FILL PIECE MUST BE INSTALLED IN SEGMENTS DESIGNED TO FIT BETWEEN THE "TIE-BARS" VERTICALLY. THE FILL PIECE(S) IS NOT REQUIRED WHEN THE CORNER PORTIONS OF THE CONTAINER FORWARD WALL ARE SMOOTH AND FLAT. DO NOT ALLOW ANY DUNNAGE ASSEMBLY TO CONTACT THE CONTAINER FORWARD WALL, ONLY THE CORNER POSTS OF THE CONTAINER SHOULD BE USED FOR FORWARD LONGITUDINAL BLOCKING.
- H. WHETHER A CONTAINER IS FULL OR IS LOADED WITH A REDUCED QUANTITY OF LADING UNITS, THE LENGTHWISE CENTER OF GRAVITY OF THE LOAD MUST BE WITHIN 12", IN EITHER DIRECTION, OF THE MID-POINT OF THE CONTAINER.

- J. CAUTION: DO NOT NAIL DUNNAGE MATERIAL TO THE CONTAINER WALLS OR FLOOR. ALL NAILING WILL BE WITHIN THE DUNNAGE.
- K. PORTIONS OF THE CONTAINER DEPICTED WITHIN THIS DRAWING, SUCH AS THE SIDEWALL, HAVE NOT BEEN SHOWN IN THE LOAD VIEWS FOR CLARITY PURPOSES.
- L. MAXIMUM LOAD WEIGHT CRITERIA:  
  
THE MAXIMUM LOAD WEIGHTS ARE CONTROLLED BY EQUIPMENT CAPABILITY FACTORS. ALTHOUGH THE HEAVIEST MAXIMUM LOAD IS DELINEATED IN THE LOAD VIEW, PROVISIONS ARE INCLUDED WITHIN THIS DRAWING SO THAT THE BASIC LOAD CAN BE ADJUSTED TO SATISFY A LESSER QUANTITY OF LADING UNITS. DEPENDING ON TRANSPORTATION ROUTING, IT MAY BE NECESSARY TO REDUCE THE LOAD WEIGHT TO SATISFY "WEIGHT LAWS" OF CERTAIN STATES. ALSO, IT MAY BE NECESSARY TO REDUCE THE LOAD WEIGHT TO SATISFY OTHER WEIGHT RESTRICTIONS IMPOSED ON THE INTERMODAL CONTAINER SYSTEM.
- M. REQUIREMENTS CITED WITHIN THE BUREAU OF EXPLOSIVES PAMPHLET 6C APPLY WHEN THE SHIPMENT MOVES BY TRAILER/CONTAINER-ON-FLATCAR (T/COFC). SPECIAL T/COFC NOTES FOLLOW:
  - 1. A LOADED CONTAINER MUST BE ON A CHASSIS EQUIPPED WITH TWO BOGIE ASSEMBLIES WHEN BEING MOVED IN TOPC SERVICE.
  - 2. THE LOAD LIMIT OF A T/COFC RAILCAR MUST NOT BE EXCEEDED, NOR WILL A CAR BE LOADED SO THAT THE TRUCK UNDER ONE END OF THE CAR CARRIES MORE THAN ONE-HALF OF THE LOAD LIMIT FOR THAT CAR.
- N. DURING INTRASTATE AND/OR INTERSTATE MOVES BY MOTOR CARRIER, A PROPER CHASSIS OR MODIFIED FLATBED TRAILER MUST BE USED TO PRECLUDE VIOLATION OF ONE OR MORE "WEIGHT LAWS" APPLICABLE TO THE STATE OR STATES INVOLVED.
- O. CONVERSION TO METRIC EQUIVALENTS: DIMENSIONS WITHIN THIS DOCUMENT ARE EXPRESSED IN INCHES AND WEIGHTS ARE EXPRESSED IN POUNDS. WHEN NECESSARY, THE METRIC EQUIVALENTS MAY BE COMPUTED ON THE BASIS OF ONE INCH EQUALS 25.4MM AND ONE POUND EQUALS 0.454 KG.
- P. THE QUANTITY OF CNU-246/E CONTAINERS SHOWN IN THE LOAD ON PAGE 4 MAY BE REDUCED FOR SHIPMENT, IF DESIRED. SEE THE FILLER ASSEMBLY ON PAGE 3.
  - 1. IF A LOAD IS REDUCED BY ONLY A SMALL AMOUNT (ONE OR TWO LADING UNITS), LADING UNITS NORMALLY MAY BE ELIMINATED FROM THE CENTER OF THE LOAD.
  - 2. IF A LOAD IS REDUCED BY A LARGE AMOUNT (MORE THAN TWO LADING UNITS), LADING UNITS SHOULD BE ELIMINATED AS REQUIRED AND THE TOTAL LOAD SHIFTED FORE OR AFT, AS NECESSARY, TO ACHIEVE A SYMMETRICAL WEIGHT DISTRIBUTION. THE DEPICTED PROCEDURES WILL BE FOLLOWED AS CLOSELY AS POSSIBLE, MAKING ONLY THOSE ADJUSTMENTS TO THE DUNNAGE WHICH ARE REQUIRED TO ACCOMMODATE THE NUMBER OF UNITS TO BE SHIPPED.

(CONTINUED AT RIGHT)

MATERIAL SPECIFICATIONS

- LUMBER - - - - - : SEE TM 743-200-1 (DUNNAGE LUMBER) AND FED SPEC MM-L-751.
- NAILS - - - - - : FED SPEC FF-N-105; COMMON.
- PLYWOOD - - - - - : COMMERCIAL ITEM DESCRIPTION A-A-55057, TYPE A, CONSTRUCTION AND INDUSTRIAL PLYWOOD, INTERIOR WITH EXTERIOR GLUE, GRADE C-D. IF SPECIFIED GRADE IS NOT AVAILABLE, A BETTER INTERIOR OR AN EXTERIOR GRADE MAY BE SUBSTITUTED.
- STEEL, STRUCTURAL - - : ASTM A501, STEEL STRUCTURAL TUBING; AND ASTM A570, STEEL, STRIP, HOT-ROLLED, GRADE 36 (MINIMUM).
- WIRE, CARBON STEEL - - : ASTM A853; ANNEALED AT FINISH, BLACK OXIDE FINISH. .0800" DIA OR BETTER.

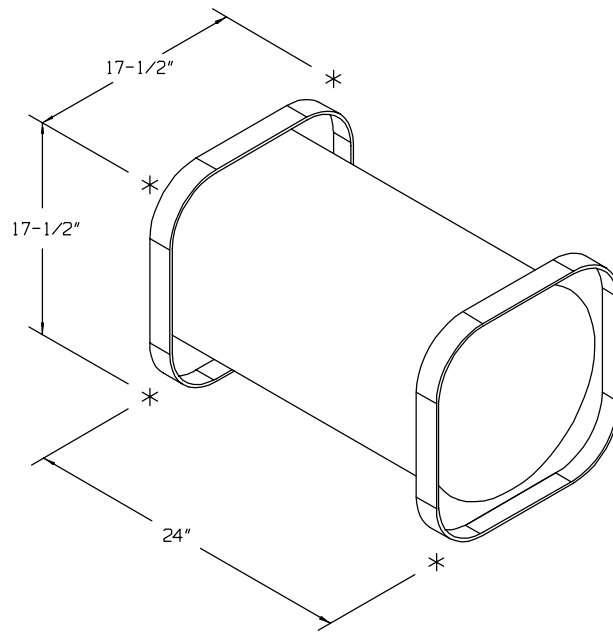

**CONTAINER DETAIL**

UNIT WEIGHT - - - 70 POUNDS (APPROX)  
 CUBE - - - - - 4.25 CU FT (APPROX)

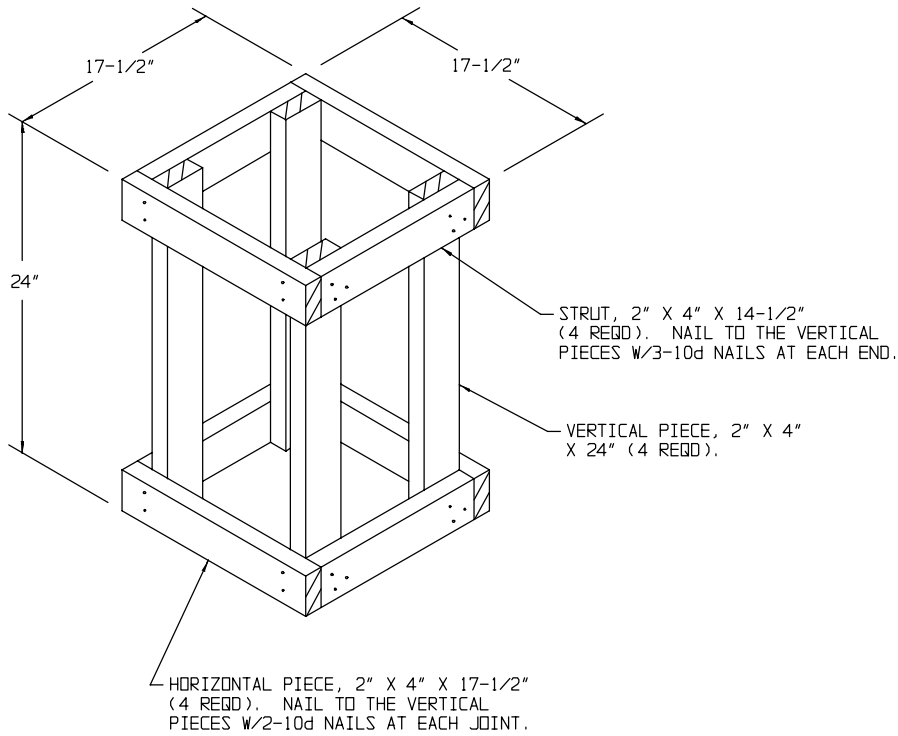

**FILLER ASSEMBLY**

NOTE: WHEN THE FILLER ASSEMBLY IS USED WITHIN THE LOAD SHOWN ON PAGE 4, THE TOP HORIZONTAL PIECES WILL BE WIRE TIED TO THE CNU-246/E CONTAINERS.

**DETAILS**

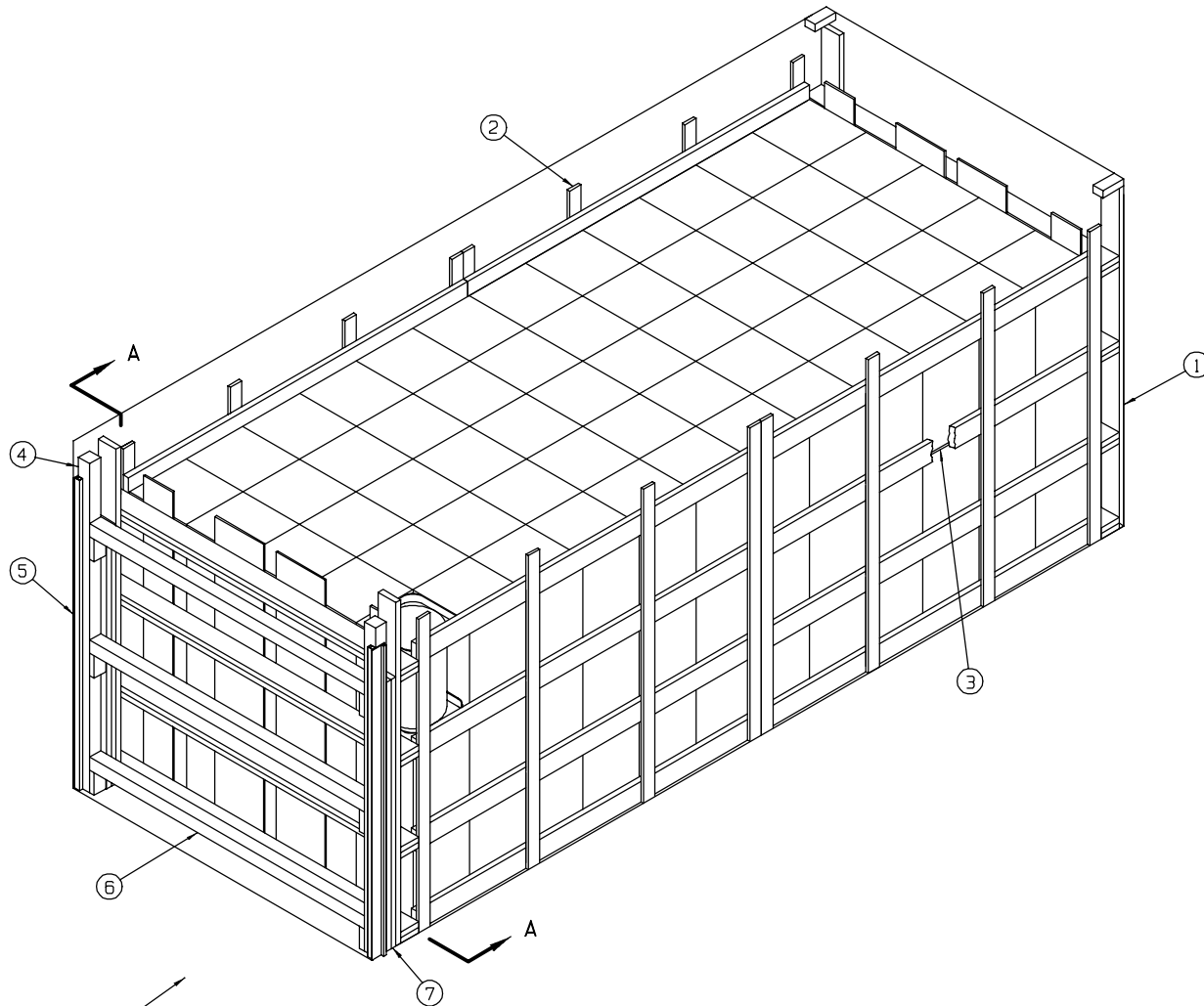

REAR OF CONTAINER.

**ISOMETRIC VIEW**

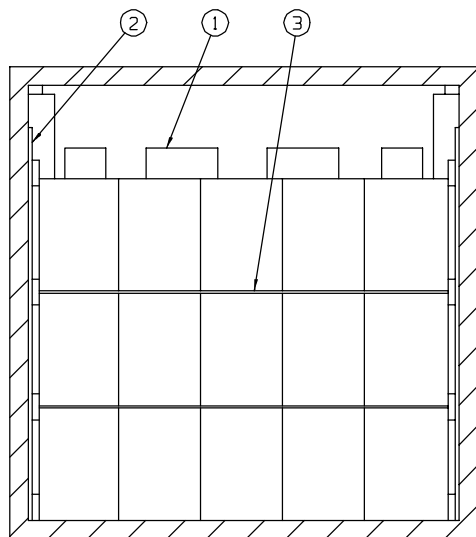

**SECTION A-A**

**KEY NUMBERS**

- ① FORWARD/REAR BLOCKING ASSEMBLY (2 REQD). SEE THE DETAIL ON PAGE 6. SEE GENERAL NOTES "F" AND "G" ON PAGE 2.
- ② SIDE FILL ASSEMBLY (4 REQD). SEE THE DETAIL ON PAGE 5. SEE GENERAL NOTE "D" ON PAGE 2.
- ③ DECKING, 1/2" PLYWOOD BY 7'-3" BY WIDTH TO SUIT (AS REQD). POSITION BETWEEN LAYERS OF CONTAINERS AS SHOWN.
- ④ DOOR POST VERTICAL (2 REQD). SEE THE "DOOR POST VERTICAL" DETAIL AND "DETAIL B" ON PAGE 8.
- ⑤ DOOR POST VERTICAL RETAINER (2 REQD). SEE THE "DOOR POST VERTICAL RETAINER" DETAILS ON PAGE 7 AND "DETAIL A" ON PAGE 8. NAIL THROUGH THE HOLES INTO THE DOOR POST VERTICAL W/4-10d NAILS.
- ⑥ DOOR SPANNER, 4" X 4" MATERIAL CUT TO A LENGTH THAT WILL PROVIDE FOR A DRIVE FIT (REF: 7'-1-3/8") (3 REQD). TOE-NAIL TO THE 4" X 4" DOOR POST VERTICAL PIECES W/2-12d NAILS AT EACH END. SEE THE "BEVEL-CUT" DETAIL ON PAGE 8. AFTER INSTALLING THE BOTTOM AND TOP DOOR SPANNER, THE FILL MATERIAL, PIECE MARKED ⑦, IS TO BE INSTALLED.
- ⑦ FILL MATERIAL, 6" WIDE BY 72" LONG MATERIAL (AS REQD). NAIL EACH PIECE TO THE REAR BLOCKING ASSEMBLY AND/OR LAMINATE TOGETHER W/6 NAILS OF A SUITABLE SIZE (10d FOR 2" MATERIAL). CAUTION: DO NOT NAIL TO THE DOOR POST VERTICALS, PIECE MARKED ④.

VERTICAL PIECE, 1" X 4"  
X 7'-0" (4 REQD). NAIL TO  
THE HORIZONTAL PIECES  
W/3-6d NAILS AT EACH JOINT.

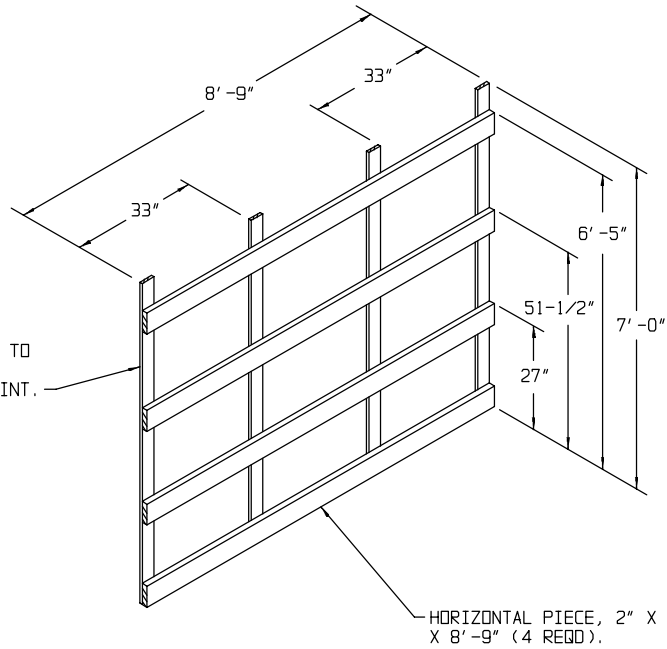

SIDE FILL ASSEMBLY

BILL OF MATERIAL		
LUMBER	LINEAR FEET	BOARD FEET
1" X 4"	112	38
2" X 4"	3	2
2" X 6"	316	316
4" X 4"	36	48
NAILS	NO. REQD	POUNDS
6d (2")	448	2-1/2
10d (3")	140	2
12d (3-1/4")	12	1/4
DOOR POST VERTICAL RETAINER - 2 REQD - - - - 64 LBS		
PLYWOOD, 1/2" - - - - 307 SQ FT REQD - - - - 422 LBS		

LOAD AS SHOWN

ITEM	QUANTITY	WEIGHT (APPROX)
CNU-246/E CNTR	180	12,600 LBS
DUNNAGE		1,300 LBS
CONTAINER		4,700 LBS
<b>TOTAL WEIGHT</b>		<b>18,600 LBS (APPROX)</b>

BUFFER PIECE, 2" X 6" BY INSIDE  
CONTAINER HEIGHT MINUS 1"  
(REF: 7'-6" IN FORWARD END OF  
CONTAINER AND 7'-8" IN REAR OF  
CONTAINER) (2 REQD). NAIL THRU  
PLYWOOD INTO THE BEAMS W/3-10d  
NAILS AT EACH JOINT.

SEE GENERAL NOTE "G"  
ON PAGE 2.

PLYWOOD, 1/2" X 9" X 6'-8" (2 REQD)  
AND 1/2" X 15" X 6'-8" (2 REQD).  
NAIL TO EACH BEAM LAMINATION  
W/4-6d NAILS AT EACH JOINT.

BEAM, 2" X 6" BY INSIDE  
CONTAINER WIDTH MINUS 1"  
(DOUBLED) (REF: 7'-7")  
(4' REQD). LAMINATE  
W/11-10d NAILS.

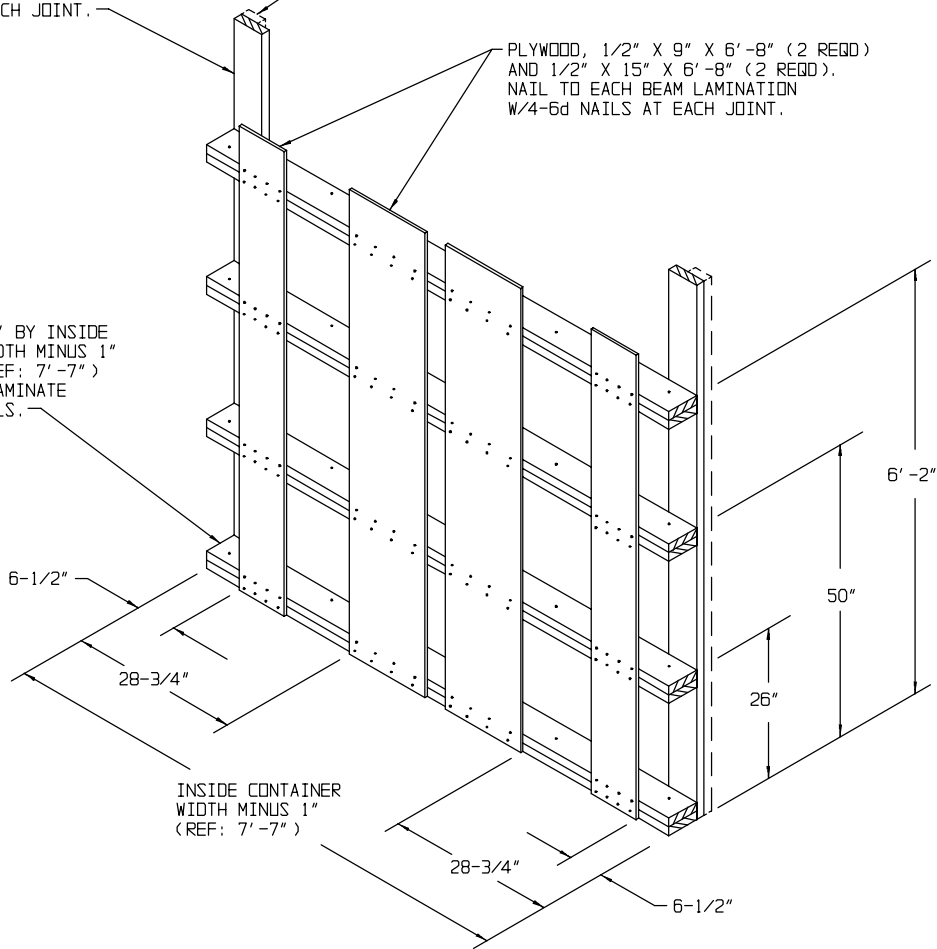

FORWARD/REAR BLOCKING ASSEMBLY

STEEL STRIP, 1/8" THICK BY 4" WIDE  
BY 83" LONG (1.70 LBS/FT).

SQUARE STRUCTURAL TUBING, 3/4" SQUARE  
BY .120" WALL THICKNESS BY 83" LONG  
(1.03 LBS/FT).

RECTANGULAR STRUCTURAL TUBING,  
1-1/2" BY 1" BY .120" WALL  
THICKNESS BY 83" LONG (1.84 LBS/FT).

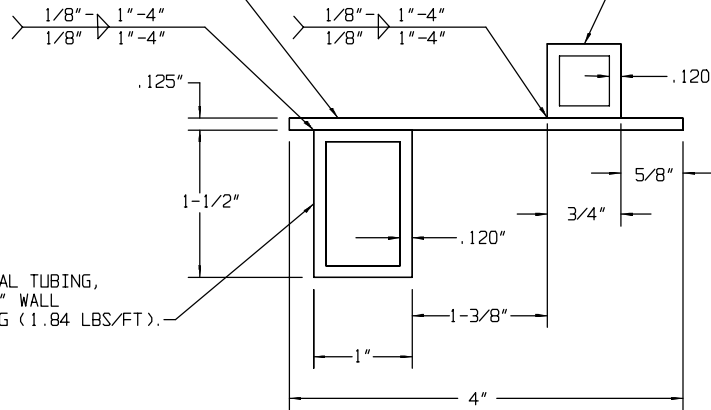

**VIEW A**

**SPECIAL NOTE:**

IN MOST CORRUGATED STEEL CONTAINERS, LASHING OR TIE BARS WILL BE PRESENT IN THE SLOT WHERE THE 3/4" SQUARE STRUCTURAL TUBING IS TO BE INSTALLED. TO ENSURE PROPER ENGAGEMENT OF THE SQUARE TUBING AND THE CONTAINER DOOR POST, THE TUBING MUST BE NOTCHED AT THE TIE BAR LOCATIONS.

SQUARE STRUCTURAL TUBING,  
3/4" SQUARE BY .120" WALL  
THICKNESS BY 83" LONG  
(1.03 LBS/FT).

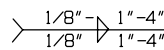

RECTANGULAR STRUCTURAL TUBING,  
1-1/2" BY 1" BY .120" WALL THICKNESS  
BY 83" LONG (1.84 LBS/FT).

DRILL 5/32", 4 HOLES.

STEEL STRIP, 1/8" THICK BY 4" WIDE  
BY 83" LONG (1.70 LBS/FT).

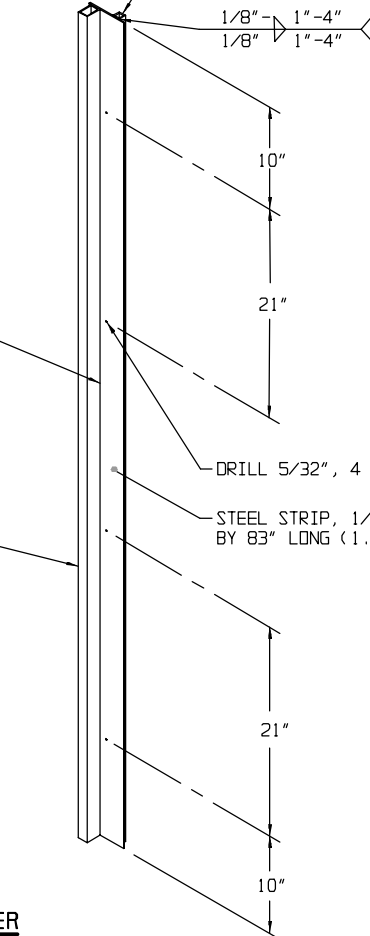

**DOOR POST VERTICAL RETAINER**

NOTE: THE ABOVE ASSEMBLY HAS BEEN SHOWN ROTATED 90° FROM THE ORIENTATION IN WHICH IT IS INSTALLED IN THE LEFT REAR CORNER OF THE CONTAINER. THE ASSEMBLY HAS BEEN ROTATED FOR HOLE LOCATION CLARITY.

**DETAILS**

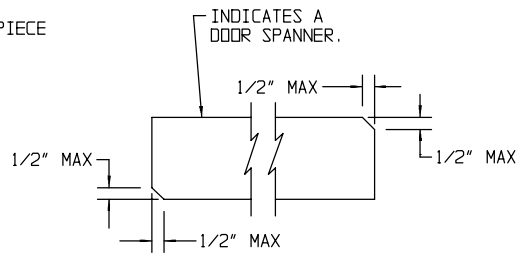
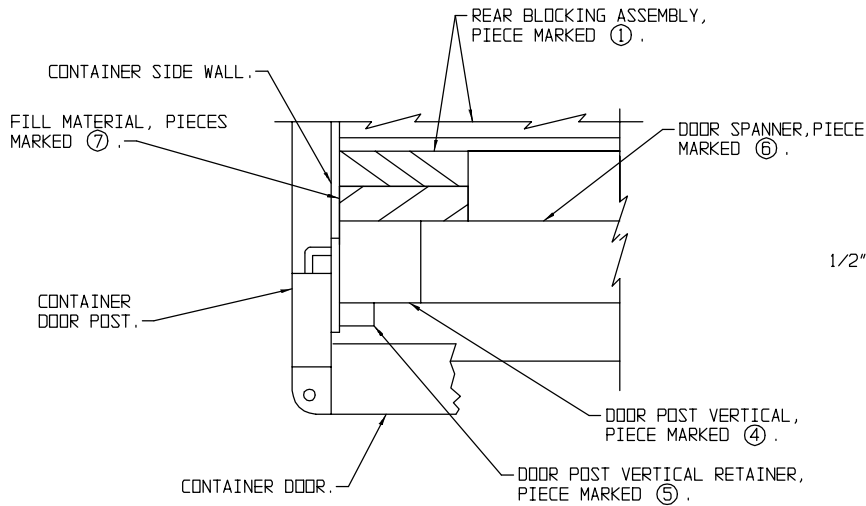

**BEVEL-CUT**

IF DESIRED, EACH END OF A DOOR SPANNER PIECE MAY BE BEVEL-CUT AS SHOWN ABOVE TO FACILITATE THE ACHIEVEMENT OF A TIGHT DOOR-POST-TO-DOOR-POST FIT.

**DETAIL A**

A PARTIAL PLAN VIEW OF THE LEFT REAR PORTION OF THE CONTAINER IS SHOWN DEPICTING THE PROPER POSITION OF THE DOOR POST VERTICAL AND ADJACENT DUNNAGE PIECES.

VERTICAL PIECE, 4" X 4" BY INSIDE CONTAINER HEIGHT MINUS 1/2" (REF: 7'-4") (1 REQD).

STRUT LEDGER, 2" X 4" X 6" (3 REQD). NAIL TO THE VERTICAL PIECE W/2-10d NAILS.

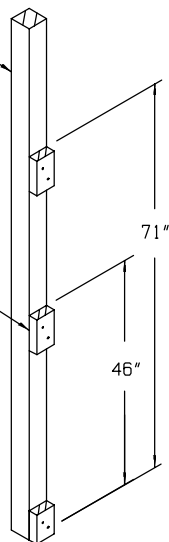

**DOOR POST VERTICAL**

DOOR POST VERTICAL, PIECE MARKED ④.

DOOR POST VERTICAL RETAINER, PIECE MARKED ⑤.

BUFFER PIECE OF "REAR BLOCKING ASSEMBLY", PIECE MARKED ①.

FILL MATERIAL, PIECE MARKED ⑦.

FRONT OF CONTAINER.

**DETAIL B**

DOOR SPANNERS AND STRUT LEDGERS HAVE BEEN OMITTED FOR CLARITY PURPOSES.

**DETAILS**