

APPROVED BY  
BUREAU OF EXPLOSIVES

*David L. Healy*

DATE 9-9-94

# LOADING AND BRACING<sup>●</sup> IN MILVAN CONTAINERS<sup>⊕</sup> OF TRI-SERVICE STANDOFF ATTACK MISSILES (TSSAM) PACKED IN CNU-446/E SHIPPING AND STORAGE CONTAINERS

## INDEX

<u>ITEM</u>	<u>PAGE(S)</u>
TYPICAL LOADING PROCEDURES - - - - -	2
GENERAL NOTES AND MATERIAL SPECIFICATIONS - - - - -	3
CNU-446/E CONTAINER DETAIL - - - - -	4
DETAILS - - - - -	5
LESS-THAN-FULL-LOAD DETAILS - - - - -	6

● LOADING AND BRACING SPECIFICATIONS SET FORTH WITHIN THIS DRAWING ARE APPLICABLE TO LOADS THAT ARE TO BE SHIPPED BY TRAILER/CONTAINER-ON-FLATCAR (T/COFC) RAIL CARRIER SERVICE. THESE SPECIFICATIONS MAY ALSO BE USED FOR LOADS THAT ARE TO BE MOVED BY MOTOR OR WATER CARRIERS.

⊕ ONLY MILVAN CONTAINERS WHICH HAVE BEEN MODIFIED TO INCLUDE A MECHANICAL LOAD-BRACING SYSTEM THAT SATISFIES THE REQUIREMENTS OF THE BUREAU OF EXPLOSIVES PAMPHLET 6C WILL BE USED FOR THE MOVEMENT OF AMMUNITION BY T/COFC SERVICE.  
CAUTION: OTHER REQUIREMENTS OF PAMPHLET 6C ALSO APPLY.

## U.S. ARMY MATERIEL COMMAND DRAWING

APPROVED, U.S. ARMY ARMAMENT, MUNITIONS AND CHEMICAL COMMAND	DRAFTSMAN	TECHNICIAN	ENGINEER
			L. FIEFFER
APPROVED BY ORDER OF COMMANDING GENERAL, U.S. ARMY MATERIEL COMMAND	VALIDATION ENGINEERING DIVISION	TRANSPORTATION ENGINEERING DIVISION	LOGISTICS ENGINEERING OFFICE
	<i>William F. Ernst</i>		
U.S. ARMY DEFENSE AMMUNITION CENTER AND SCHOOL	SEPTEMBER 1994		
	CLASS	DIVISION	DRAWING
	19	48	8591
			FILE
			SP15J70

DO NOT SCALE

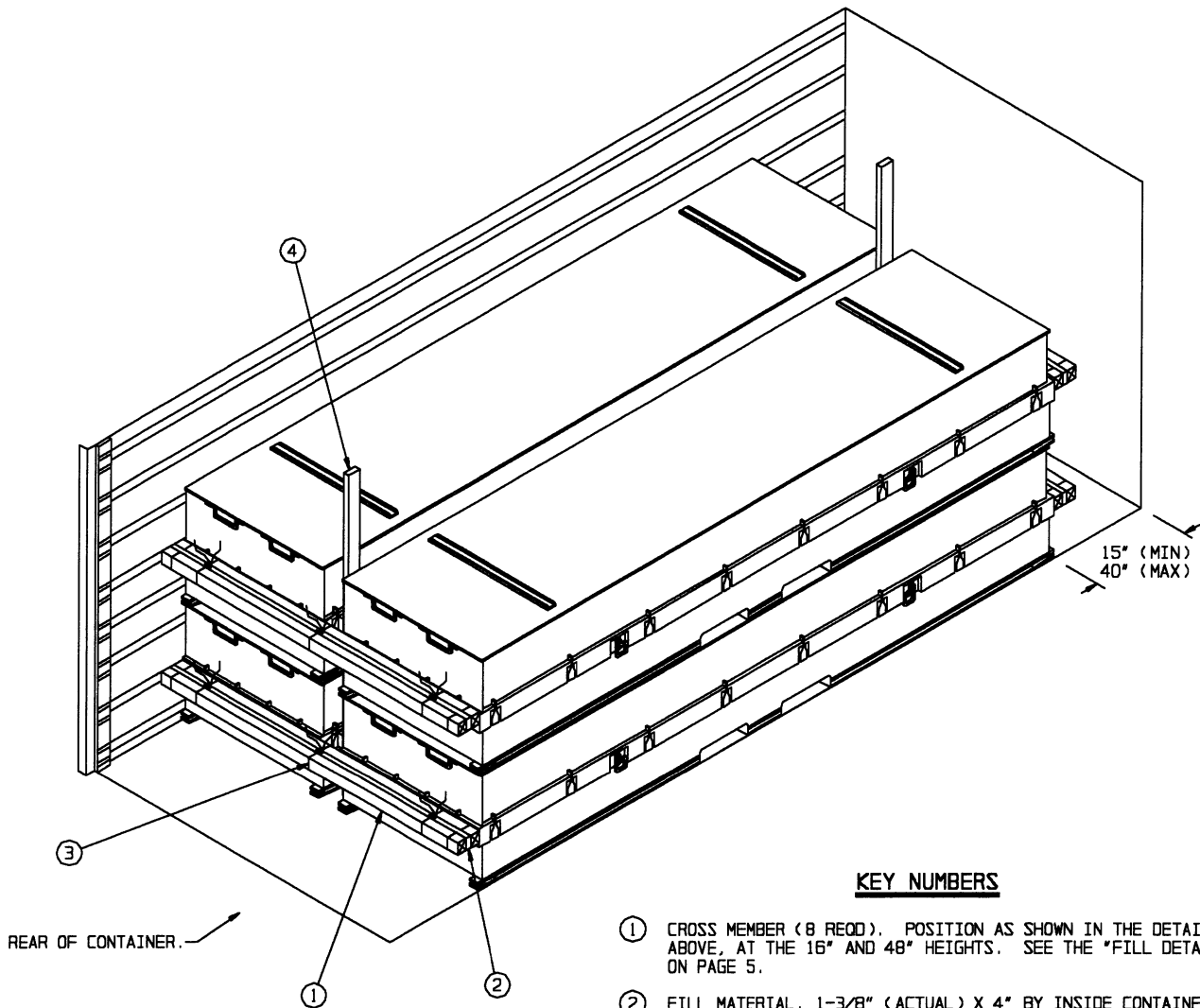

ISOMETRIC VIEW

KEY NUMBERS

- ① CROSS MEMBER (8 REQD). POSITION AS SHOWN IN THE DETAIL ABOVE, AT THE 16" AND 48" HEIGHTS. SEE THE "FILL DETAIL" ON PAGE 5.
- ② FILL MATERIAL, 1-3/8" (ACTUAL) X 4" BY INSIDE CONTAINER WIDTH MINUS 1" (REF: 7'-7") (4 REQD).
- ③ TIE WIRE, NO. 14 GAGE WIRE 24" LONG (12 REQD). INSTALL TO FORM A COMPLETE LOOP AROUND THE CROSS MEMBERS AND THE FILL MATERIAL, BRING ENDS TOGETHER AND TWIST TAUT. SECURE TO THE FILL MATERIAL WITH A PARTIALLY DRIVEN 10d NAIL BENT OVER THE WIRE, OR WITH A STRAP STAPLE.
- ④ CENTER FILL ASSEMBLY (1 REQD). SEE THE DETAIL ON PAGE 5.

BILL OF MATERIAL

LUMBER	LINEAR FEET	BOARD FEET
2" X 4"	110	74
NAILS	NO. REQD	POUNDS
10d (3")	44	3/4
WIRE, NO. 14 GAGE	24' REQD	0.40 LBS
CROSS MEMBER		8 REQD

LOAD AS SHOWN

ITEM	QUANTITY	WEIGHT (APPROX)
CNU-446/E	4	13,400 LBS
DUNNAGE		150 LBS
CONTAINER		5,700 LBS

TOTAL WEIGHT ----- 19,250 LBS (APPROX)

(GENERAL NOTES CONTINUED)

GENERAL NOTES

J. TO MAKE LOADING EASIER, TO HELP ACHIEVE A TIGHT LOAD ACROSS A CONTAINER, AND TO PREVENT UNACCEPTABLE DAMAGE TO LADING UNITS WHEN LOADING A MILVAN, A SLIP-SHEET CAN BE USED EFFECTIVELY AS A "SHOEHORN" TYPE DEVICE. THE SLIP-SHEET WILL PROVIDE A SMOOTH SURFACE THAT WILL PREVENT CONTAINERS FROM INTERLOCKING OR CATCHING ON OTHER PROJECTIONS WHEN LATERALLY ADJACENT LADING UNITS ARE BEING LOADED. A SLIP-SHEET WILL BE USED AFTER ONE-HALF OF A STACK IS LOADED WITH ONE OF ITS SIDES IN TIGHT CONTACT AT ONE SIDE OF THE MILVAN. THE SLIP-SHEET IS TO BE PLACED AGAINST THE OTHER SIDE OF THE HALF-STACK BEFORE THE LAST HALF OF THE STACK IS LOADED. AFTER A STACK IS COMPLETED, THE SLIP-SHEET IS TO BE REMOVED FOR SUBSEQUENT USE WITH THE NEXT STACK. A SLIP-SHEET OF SUITABLE SIZE CAN BE MADE FROM A SHEET OF 1/8" TEMPERED HARDBOARD (MASONITE) OR FROM A SHEET OF ANY OTHER MATERIAL THAT WILL SATISFY THE REQUIREMENTS.

K. MAXIMUM LOAD WEIGHT CRITERIA:

THE MAXIMUM LOAD WEIGHTS ARE CONTROLLED BY EQUIPMENT CAPABILITY FACTORS. ALTHOUGH THE HEAVIEST MAXIMUM LOADS ARE DELINEATED IN THE LOAD VIEWS, PROVISIONS ARE INCLUDED WITHIN THIS DRAWING SO THAT THE BASIC LOADS CAN BE ADJUSTED TO SATISFY A LESSER QUANTITY OF LADING UNITS. DEPENDING ON TRANSPORTATION ROUTING, IT MAY BE NECESSARY TO REDUCE THE LOAD WEIGHT TO SATISFY "WEIGHT LAWS" OF CERTAIN STATES. ALSO, IT MAY BE NECESSARY TO REDUCE THE LOAD WEIGHT TO SATISFY OTHER WEIGHT RESTRICTIONS IMPOSED ON THE INTERMODAL CONTAINER SYSTEM.

L. SPECIAL T/COFC NOTES:

- 1. CAUTION: LOADED CONTAINERS MUST BE ON CHASSIS EQUIPPED WITH TWO BOGIE ASSEMBLIES WHEN BEING MOVED IN TOFC SERVICE, REGARDLESS OF THE LOAD WEIGHT WITHIN THE CONTAINER.
2. LOAD LIMITS OF T/COFC RAIL CARS MUST NOT BE EXCEEDED, NOR WILL A CAR BE LOADED SO THAT THE TRUCK UNDER ONE END OF THE CAR CARRIES MORE THAN ONE-HALF OF THE LOAD LIMIT FOR THAT CAR.
3. CHASSIS/CONTAINERS COUPLED INTO A 40-FOOT TRAILER CONFIGURATION MUST BE PLACED AT THE B-END OF A TOFC RAIL CAR. THE REAR END OF THE 40-FOOT UNIT WILL OVERHANG THE END OF THE CAR IF IT IS PLACED AT THE A-END. TWENTY-FOOT AND 40-FOOT UNITS CAN BE LOADED ON THE SAME CAR.

M. WHEN LOADING CONTAINERS, THEY ARE TO BE POSITIONED SO AS TO ACHIEVE A TIGHT LOAD (TIGHT AGAINST THE DUNNAGE ASSEMBLIES). THE UNBLOCKED SPACE ACROSS THE WIDTH OF A LOAD BAY IS NOT TO EXCEED 1-1/2". EXCESSIVE SLACK CAN BE ELIMINATED FROM A LOAD BY LAMINATING ADDITIONAL PIECES OF APPROPRIATE THICKNESS TO THE CENTER FILL ASSEMBLIES. NAIL EACH ADDITIONAL PIECE TO THE HORIZONTAL PIECE W/1 APPROPRIATELY SIZED NAIL EVERY 12". ADDITIONALLY, THE THICKNESS AND QUANTITY OF THE DUNNAGE LUMBER USED MAY BE ADJUSTED AS REQUIRED TO FACILITATE VARIANCE IN THE SIZE OF THE CONTAINER.

N. THE QUANTITY OF CONTAINERS SHOWN IN THE LOAD ON PAGE 2 MAY BE REDUCED FOR SHIPMENT, IF DESIRED. SEE THE "LESS-THAN-FULL LOAD" DETAIL ON PAGE 6. WHEN A MILVAN IS TO BE LOADED WITH A REDUCED QUANTITY OF LADING UNITS, THE LENGTHWISE CENTER OF GRAVITY OF THE LOAD MUST BE WITHIN 12", IN EITHER DIRECTION, OF THE MID-POINT OF THE MILVAN.

O. ANTI-CHAFING MATERIAL MAY BE INSTALLED AT POINTS OF CONTACT BETWEEN CONTAINERS AND THE MILVAN, AND BETWEEN CONTAINERS AND STEEL STRAPPING, IF DESIRED, TO PREVENT CHAFING DAMAGE TO CONTAINER PAINT AND MARKINGS.

P. CONVERSION TO METRIC EQUIVALENTS: DIMENSIONS WITHIN THIS DOCUMENT ARE EXPRESSED IN INCHES, AND WEIGHTS ARE EXPRESSED IN POUNDS. WHEN NECESSARY, THE METRIC EQUIVALENTS MAY BE COMPUTED ON THE BASIS OF ONE INCH EQUALS 25.4 MM AND ONE POUND EQUALS 0.454 KG.

A. THIS DOCUMENT HAS BEEN PREPARED AND ISSUED IN ACCORDANCE WITH AR 740-1 AND AUGMENTS TM 743-200-1 (CHAPTER 5).

B. THE OUTLOADING PROCEDURES SPECIFIED IN THIS DRAWING ARE APPLICABLE TO LOADS OF TRI-SERVICE STANDOFF ATTACK MISSILES (TSSAM) PACKED IN CNU-446/E CONTAINERS. SUBSEQUENT REFERENCE TO CONTAINER HEREIN MEANS THE CONTAINER WITH MISSILE INSTALLED. SEE PAGE 4 FOR DETAIL OF THE CONTAINER. CAUTION: REGARDLESS OF THE QUANTITY OF UNITS TO BE SHIPPED, THE "MAXIMUM GROSS WEIGHT" OF THE MILVAN MUST NOT BE EXCEEDED.

C. THE LOADS AS SHOWN ARE BASED ON A 20' LONG BY 8' WIDE BY 8' HIGH MILVAN CONTAINER WITH INSIDE DIMENSIONS OF 19'-4" LONG BY 92" WIDE BY 87" HIGH. THE LOADS ARE DESIGNED FOR TRAILER/CONTAINER-ON-FLATCAR (T/COFC) SHIPMENT.

D. THE SPECIFIED OUTLOADING PROCEDURES ARE FOR CONTAINERS EQUIPPED WITH SELF-CONTAINED MECHANICAL BRACING DEVICES AS DESCRIBED WITHIN BUREAU OF EXPLOSIVES PAMPHLET 6C. CROSS MEMBER ATTACHMENT FACILITIES WITHIN THESE CONTAINERS MUST PROVIDE FOR THE INSTALLATION OF LOAD BLOCKING CROSS MEMBERS AT THE HEIGHTS SPECIFIED. THE WEIGHT DIMENSIONS SPECIFIED WITHIN THIS DRAWING FOR THE INSTALLATION OF CROSS MEMBERS CONFORM WITH THE BUREAU OF EXPLOSIVES PAMPHLET 6C, WITH THE EXCEPTION THAT TWO ADDITIONAL BELT RAILS HAVE BEEN SHOWN: ONE AT 72" AND ONE AT 83" HIGH FROM THE CONTAINER FLOOR. VOIDS LENGTHWISE WITHIN THE LOAD MUST BE HELD TO A MINIMUM. CROSS MEMBERS MUST BE PLACED AGAINST THE LADING AS TIGHTLY AS THE HOLE SPACING IN THE CROSS MEMBER ATTACHMENT FACILITY PERMITS. EACH CROSS MEMBER WILL BE INSTALLED WITH THE ENDS ATTACHED AS NEARLY AS POSSIBLE IN "MATED" POSITIONS (AT EQUAL HEIGHT AND AT EQUAL DISTANCES FROM THE END OF THE CONTAINER). CROSS MEMBERS IN EMPTY CONTAINERS AND THOSE NOT USED IN LOADED CONTAINERS MUST BE FASTENED INTO BELT RAILS FOR SHIPMENT. COMPONENTS ASSIGNED TO EACH CONTAINER MUST REMAIN THEREWITH EVEN THOUGH UNUSED DURING SOME SHIPMENTS. SEE THE "FILL DETAIL" ON PAGE 5 FOR THE DUNNAGING METHOD REQUIRED TO ELIMINATE AN EXCESSIVE LENGTHWISE VOID WITHIN A LOAD. THE LOAD BLOCKING COMPONENT DESIGNATED AS "CROSS MEMBER" HEREIN, IS IDENTIFIED AS "BEAM ASSEMBLY" WITHIN TM 55-8115-200-23 & P, DATED DECEMBER 1979. THE BEAM ASSEMBLY IS FURTHER IDENTIFIED AS NSN 8115-00-165-6623.

E. DUNNAGE LUMBER SPECIFIED IS OF A NOMINAL SIZE. FOR EXAMPLE, 1" X 4" MATERIAL IS ACTUALLY 3/4" THICK BY 3-1/2" WIDE AND 2" X 6" MATERIAL IS ACTUALLY 1-1/2" THICK BY 5-1/2" WIDE.

F. CAUTION: DO NOT NAIL DUNNAGE MATERIAL TO THE MILVAN WALLS OR FLOOR. ALL NAILING WILL BE WITHIN THE DUNNAGE.

G. A STAGGERED NAILING PATTERN WILL BE USED WHENEVER POSSIBLE WHEN NAILS ARE DRIVEN INTO JOINTS OF DUNNAGE ASSEMBLIES OR WHEN LAMINATING DUNNAGE. ADDITIONALLY, THE NAILING PATTERN FOR AN UPPER PIECE OF LAMINATED DUNNAGE WILL BE ADJUSTED AS REQUIRED SO THAT A NAIL FOR THAT PIECE WILL NOT BE DRIVEN THROUGH ONTO OR RIGHT BESIDE A NAIL IN A LOWER PIECE.

H. PORTIONS OF THE MILVAN DEPICTED WITHIN THIS DRAWING, SUCH AS ONE OF THE SIDEWALLS, HAVE NOT BEEN SHOWN IN THE LOAD VIEWS FOR CLARITY PURPOSES.

(CONTINUED AT LEFT)

MATERIAL SPECIFICATIONS

LUMBER - - - - - : SEE TM 743-200-1 (DUNNAGE LUMBER) AND FED SPEC MM-L-751.

NAILS - - - - - : FED SPEC FF-N-105; COMMON.

STRAPPING, STEEL - - : ASTM D3953; FLAT STRAPPING, TYPE 1, HEAVY DUTY, FINISH A, B (GRADE 2), OR C.

SEAL, STRAP - - - - : ASTM D3953; CLASS H, FINISH A, B (GRADE 2), OR C, DOUBLE NOTCH TYPE, STYLE I, II, OR IV.

ANTI-CHAFING MATERIAL - - - - - : MIL-B-121 (OR EQUAL); NEUTRAL BARRIER MATERIAL.

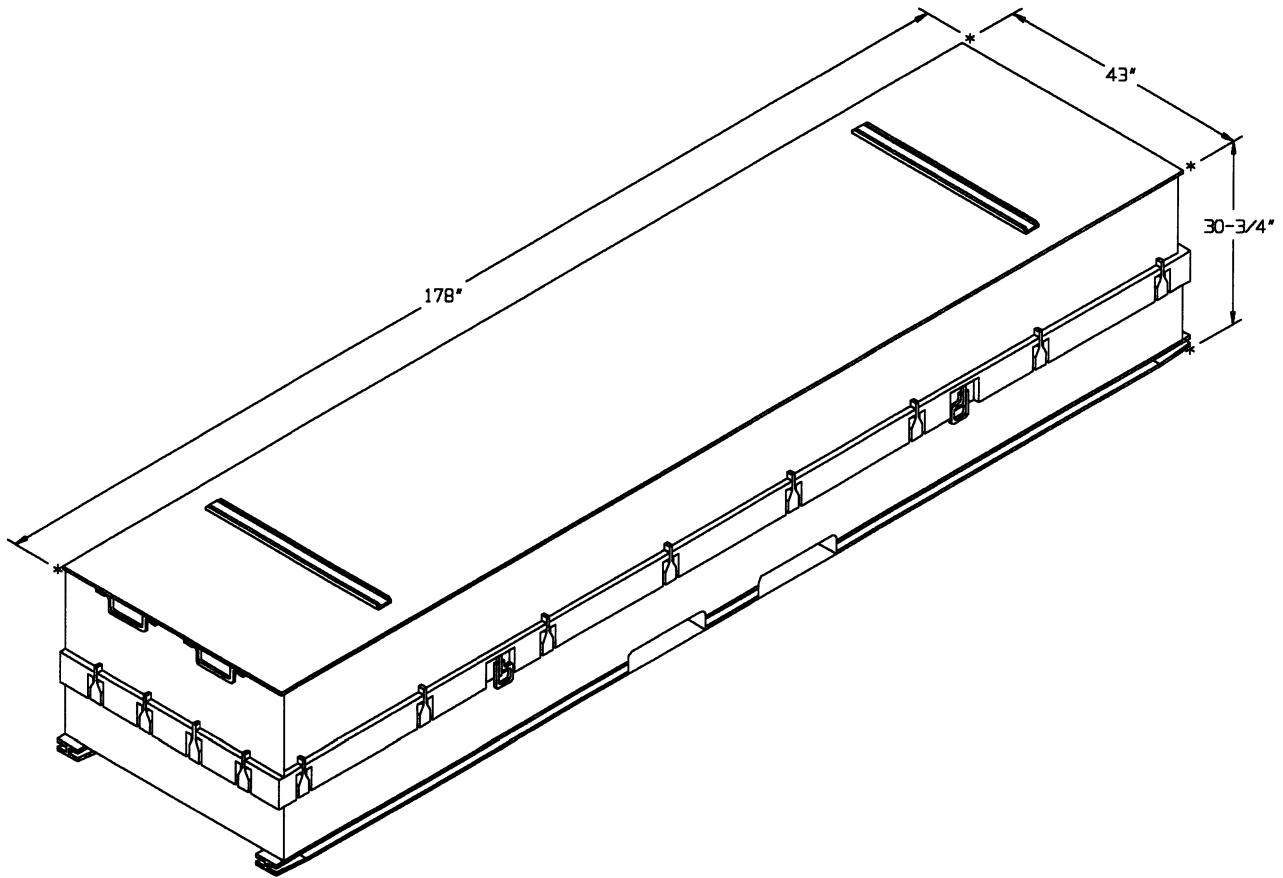

**CNU-446/E CONTAINER**

GROSS WEIGHT - - - - - 3,350 LBS (APPROX)  
 CUBE - - - - - 136.2 CUBIC FEET (APPROX)

**LOADING AND UNLOADING GUIDANCE**

(LOADING AND UNLOADING GUIDANCE CONTINUED)

1. STACKING CONTAINERS FOR LOADING.

- A. AN UPPER CONTAINER SHOULD BE PLACED AS CLOSE AS POSSIBLE IN VERTICAL ALIGNMENT WITH THE NEXT LOWER CONTAINER.
- B. POSITION THE AFT END OF AN UPPER CONTAINER ABOVE THE AFT END OF THE NEXT LOWER CONTAINER.
- C. THE CONTAINER SKIDS OF AN UPPER CONTAINER SHOULD BE FULLY SEATED AGAINST THE SKID LOCATOR PIECES ON THE COVER OF THE NEXT LOWER CONTAINER.

2. CONTAINER OR CONTAINER STACK HANDLING.

- NOTES: (1) APPROVED MATERIAL HANDLING EQUIPMENT (FORKLIFT TRUCKS, CRANES, HAND TRUCKS, DOLLIES, ROLLER ASSEMBLIES, SLINGS, SPREADER BARS, ETC.) IS SPECIFIED ELSEWHERE.
- (2) PRECAUTIONARY HANDLING TECHNIQUES NORMALLY EMPLOYED OR AS SPECIFIED FOR THE TYPE OF COMMODITY INVOLVED WILL BE OBSERVED.

(CONTINUED AT RIGHT)

- A. ONLY APPROVED AND APPROPRIATELY SIZED MATERIALS HANDLING EQUIPMENT WILL BE USED FOR HANDLING THE DEPICTED CONTAINERS.
- B. IF HANDLING IS ACCOMPLISHED WITH A FORKLIFT TRUCK, THE CONTAINERS SHOULD BE HANDLED FROM A SIDE POSITION AS MUCH AS POSSIBLE. CARE MUST BE EXERCISED WHEN INSERTING FORKS UNDER A CONTAINER, TO PREVENT DAMAGE TO THE CONTAINER BY THE FORK TINES OR THE FORKLIFT PACKAGE GUARD. IF ONE CONTAINER IS HANDLED BY SLINGING, THE SLING MAY BE ATTACHED TO THE LIFTING POINTS ON THE CONTAINER. DO NOT HANDLE STACKED CONTAINERS WITH A SLING.
- C. WHEN UNLOADING CONTAINERS, REMOVE THE LATERAL DUNNAGE, AND SHIFT THE NEAR END OF THE CONTAINER STACK TOWARDS THE CENTER OF THE MILVAN. ATTACH A CHAIN FROM THE CONTAINER LIFTING CLEVIS ON ONE SIDE OF THE CONTAINER, AROUND THE FORKLIFT MAST, TO THE CONTAINER LIFTING CLEVIS ON THE OPPOSITE SIDE OF THE CONTAINER. SLIGHTLY ELEVATE AND INSERT THE FORK TINES UNDER THE END OF THE CONTAINER STACK AND SLOWLY DRAG THE CONTAINER STACK REARWARD UNTIL IT CAN BE HANDLED FROM THE SIDE, TAKING CARE NOT TO DAMAGE THE CONTAINERS.

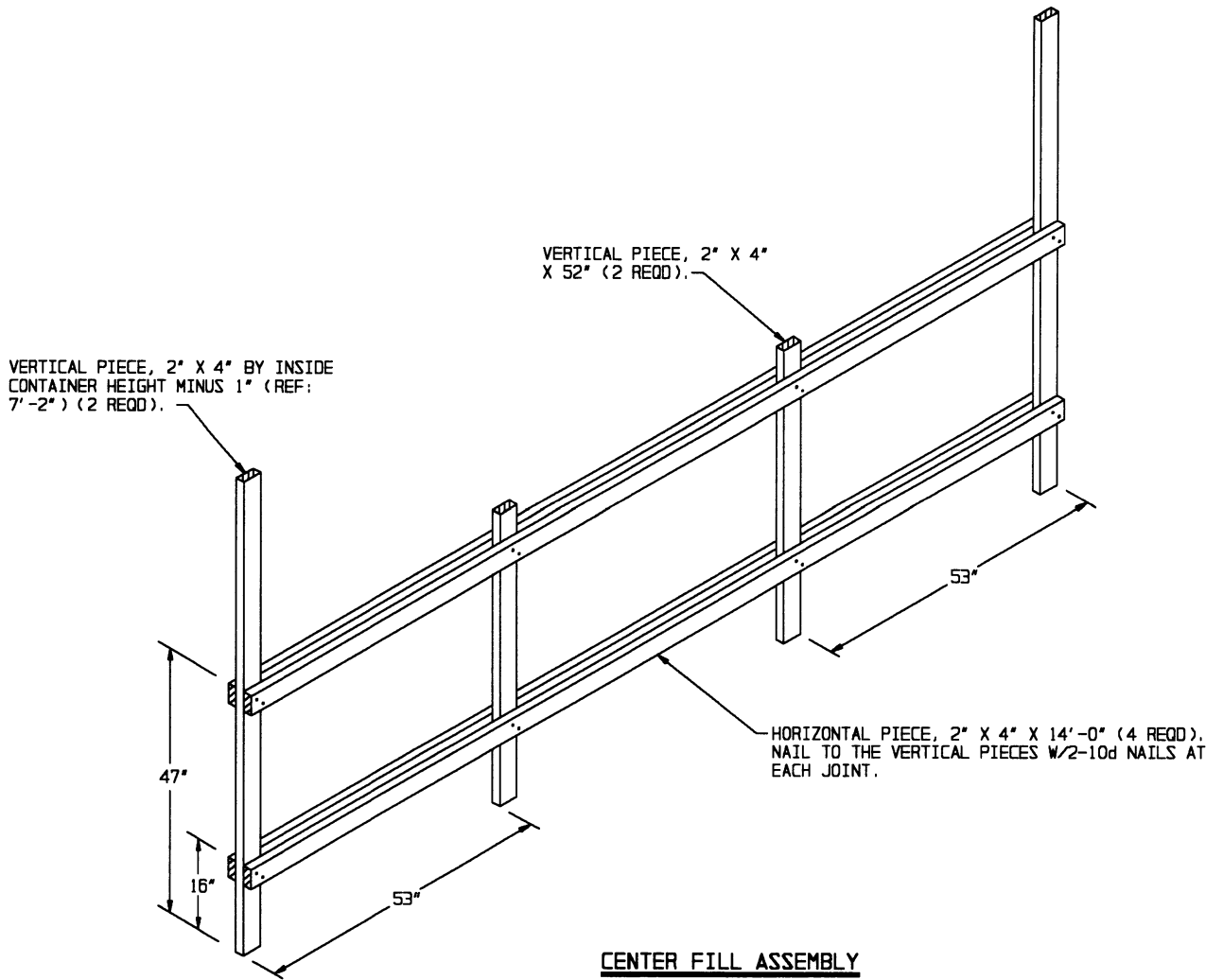

**CENTER FILL ASSEMBLY**

NOTE: FOR A ONE HIGH LOAD, LOCATE THE HORIZONTAL PIECES AT 16" AND 6". SHORTEN THE 52" VERTICAL PIECES APPROPRIATELY.

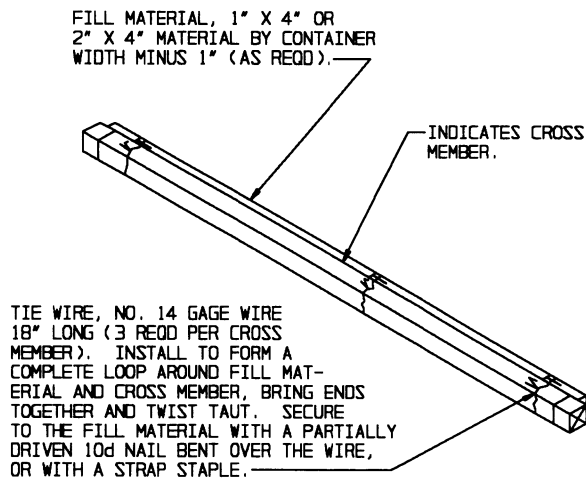

**FILL DETAIL**

THE DETAIL ABOVE DEPICTS A METHOD OF POSITIONING FILL MATERIAL BETWEEN A CROSS MEMBER AND THE LADING, WHEN THE LONGITUDINAL VOID BETWEEN THEM IS GREATER THAN 1".

UNITIZING STRAP, 1-1/4" X .035" OR .031" X 18'-0" LONG STEEL STRAPPING (2 REQD PER CONTAINER STACK). INSTALL TO ENCIRCLE TWO CONTAINERS. SEAL WITH ONE SEAL CRIMPED WITH TWO PAIR OF NOTCHES OR WITH TWO SEALS, EACH CRIMPED WITH TWO PAIR OF CRIMPS.

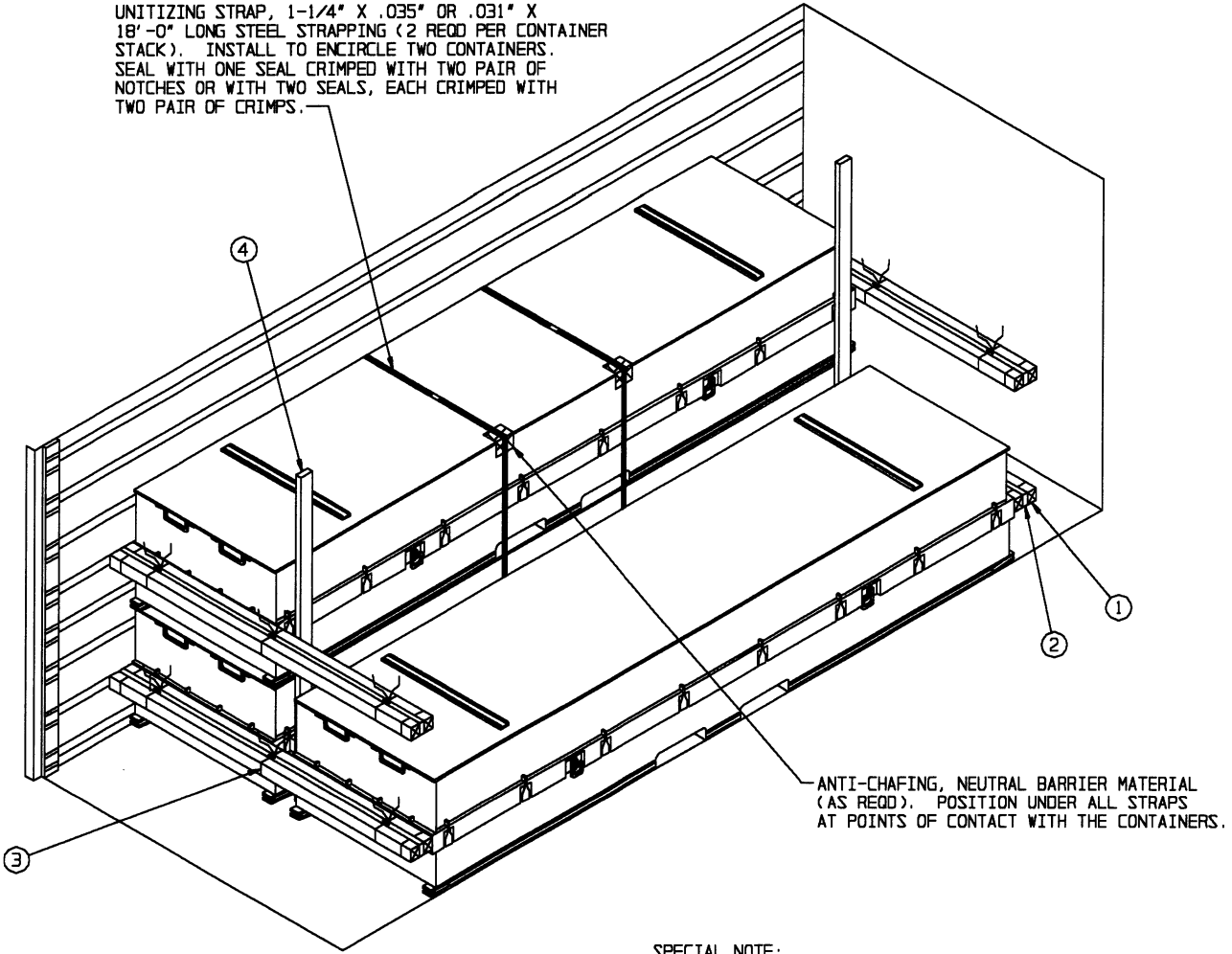

ANTI-CHAFING, NEUTRAL BARRIER MATERIAL (AS REQD). POSITION UNDER ALL STRAPS AT POINTS OF CONTACT WITH THE CONTAINERS.

SPECIAL NOTE:

WHEN REDUCING A LOAD BY ONE CONTAINER, IT WILL BE NECESSARY TO UNITIZE THE CONTAINER STACK WHICH IS Laterally ADJACENT TO THE OMITTED CONTAINER AS DEPICTED IN THE LOAD VIEW ABOVE. SEE GENERAL NOTE "N" ON PAGE 3.

ISOMETRIC VIEW

LESS-THAN-FULL-LOAD PROCEDURE

KEY NUMBERS REFER TO KEY NUMBERS ON PAGE 2. NOTE THAT THE CENTER FILL ASSEMBLY HAS BEEN MODIFIED AS DESCRIBED ON PAGE 5.