

APPROVED BY
BUREAU OF EXPLOSIVES

J. H. Sherman

DATE 5/13/94

LOADING AND BRACING WITH WOODEN DUNNAGE IN SIDE OPENING ISO CONTAINERS OF CBU ITEMS PACKED IN CNU-80/E CONTAINERS AND/OR MAU ITEMS PACKED IN CNU-203/E CONTAINERS

INDEX

<u>ITEM</u>	<u>PAGE(S)</u>
TYPICAL LOADING PROCEDURES - - - - -	2
GENERAL NOTES AND MATERIAL SPECIFICATIONS - - - - -	3
CONTAINER DETAILS - - - - -	4
DETAILS - - - - -	5,6
LESS-THAN-FULL-LOAD DETAILS - - - - -	7

- LOADING AND BRACING SPECIFICATIONS SET FORTH WITHIN THIS DRAWING ARE APPLICABLE TO LOADS THAT ARE TO BE SHIPPED BY TRAILER/CONTAINER-ON-FLATCAR (T/COFC) RAIL CARRIER SERVICE. THESE SPECIFICATIONS MAY ALSO BE USED FOR LOADS THAT ARE TO BE MOVED BY MOTOR OR WATER CARRIERS.

U.S. ARMY MATERIEL COMMAND DRAWING			
APPROVED, U.S. ARMY ARMAMENT, MUNITIONS AND CHEMICAL COMMAND <i>David E. Stackwick</i>	DRAFTSMAN	TECHNICIAN	ENGINEER L. FIEFFER
	VALIDATION ENGINEERING DIVISION	TRANSPORTATION ENGINEERING DIVISION <i>W. Frenick</i>	LOGISTICS ENGINEERING OFFICE <i>W. Frenick</i>
APPROVED BY ORDER OF COMMANDING GENERAL, U.S. ARMY MATERIEL COMMAND <i>John L. Byrd Jr.</i>	JANUARY 1994		
U.S. ARMY DEFENSE AMMUNITION CENTER AND SCHOOL	CLASS	DIVISION	DRAWING
	19	48	8576
			FILE SP15J60

DO NOT SCALE

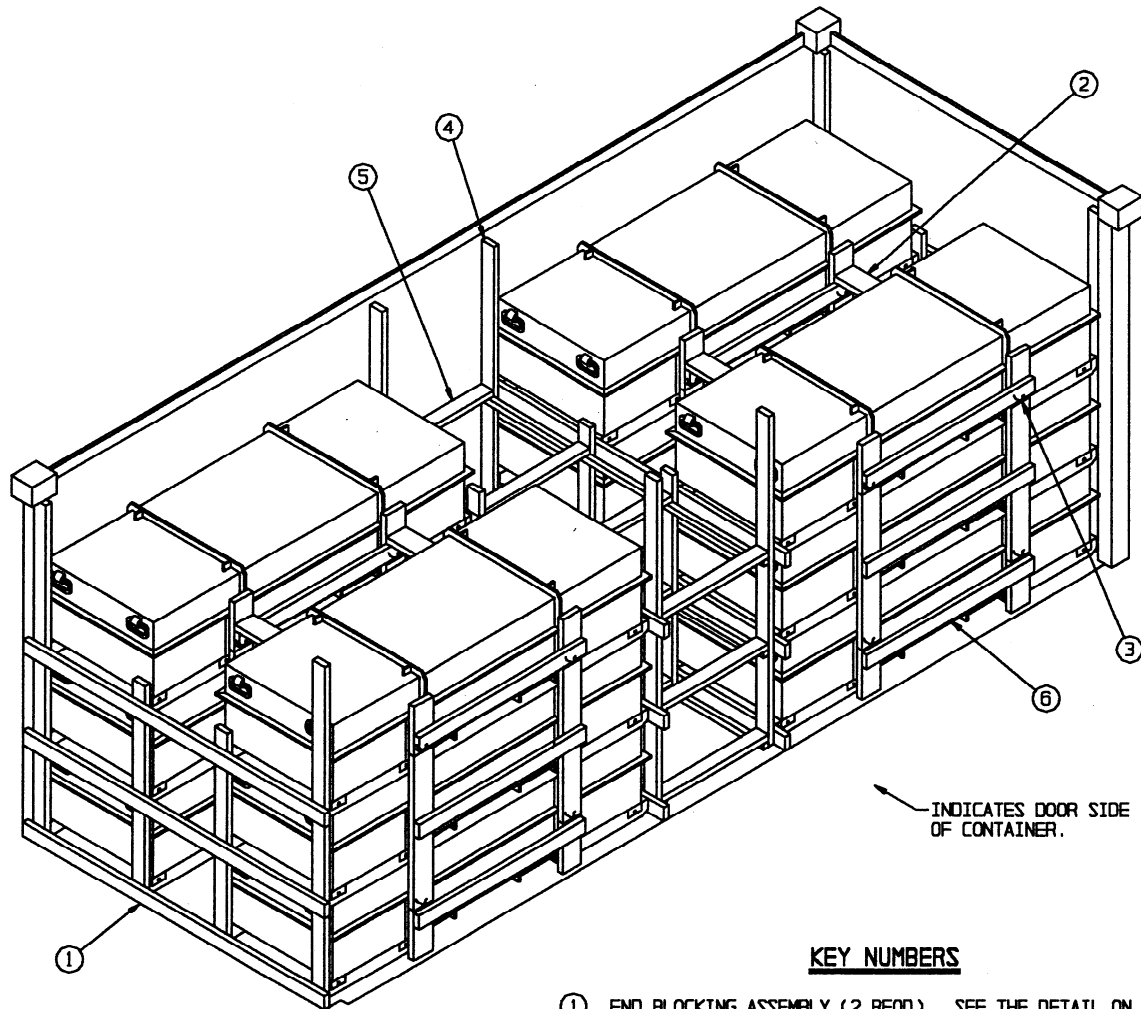

ISOMETRIC VIEW

KEY NUMBERS

- ① END BLOCKING ASSEMBLY (2 REOD). SEE THE DETAIL ON PAGE 5.
- ② CENTER FILL ASSEMBLY (2 REOD). SEE THE DETAIL ON PAGE 6.
- ③ TIE WIRE, NO. 14 GAGE WIRE 18" LONG (16 REOD). INSTALL TO FORM A COMPLETE LOOP AROUND A CENTER FILL OR SIDE FILL ASSEMBLY AND THE LIFTING BAR ON THE CONTAINER. BRING ENDS TOGETHER AND TWIST TAUT.
- ④ CENTER GATE (2 REOD). SEE THE DETAIL ON PAGE 5.
- ⑤ STRUT, 2" X 4" BY CUT-TO-FIT (REF: 31-1/4") (12 REOD). TOENAIL TO THE VERTICAL PIECES OF THE CENTER GATES 1/2-10d NAILS AT EACH END.
- ⑥ SIDE FILL ASSEMBLY (2 REOD). SEE THE DETAIL ON PAGE 6.

LOAD AS SHOWN

ITEM	QUANTITY	WEIGHT (APPROX)
CNU-80/E	12	14,088 LBS
DUNNAGE		572 LBS
CONTAINER		6,050 LBS
TOTAL WEIGHT		20,710 LBS. (APPROX)

LOAD AS SHOWN

ITEM	QUANTITY	WEIGHT (APPROX)
CNU-203/E	12	10,200 LBS
DUNNAGE		572 LBS
CONTAINER		6,050 LBS
TOTAL WEIGHT		16,822 LBS. (APPROX)

BILL OF MATERIAL

LUMBER	LINEAR FEET	BOARD FEET
2" X 2"	42	14
2" X 4"	286	191
2" X 6"	78	78
NAILS	NO. REQD	POUNDS
10d (3")	336	5-1/4
WIRE, NO. 14 GAGE - - - 24' REQD - - - - -		1/2 LBS

(GENERAL NOTES CONTINUED)

- K. CONVERSION TO METRIC EQUIVALENTS: DIMENSIONS WITHIN THIS DOCUMENT ARE EXPRESSED IN INCHES AND WEIGHTS ARE EXPRESSED IN POUNDS. WHEN NECESSARY, THE METRIC EQUIVALENTS MAY BE COMPUTED ON THE BASIS OF ONE INCH EQUALS 25.4 MM AND ONE POUND EQUALS 0.454 KG.
- L. REQUIREMENTS CITED WITHIN THE BUREAU OF EXPLOSIVES PAMPHLET 6C APPLY WHEN THE SHIPMENT MOVES BY TRAILER/CONTAINER-ON-FLATCAR (T/COFC). SPECIAL T/COFC NOTES FOLLOW:
 - 1. A LOADED CONTAINER MUST BE ON A CHASSIS EQUIPPED WITH TWO BOGIE ASSEMBLIES WHEN BEING MOVED IN TOFC SERVICE.
 - 2. THE LOAD LIMIT OF A T/COFC RAILCAR MUST NOT BE EXCEEDED, NOR WILL A CAR BE LOADED SO THAT THE TRUCK UNDER ONE END OF THE CAR CARRIES MORE THAN ONE-HALF OF THE LOAD LIMIT FOR THAT CAR.
- M. DURING INTRASTATE AND/OR INTERSTATE MOVES BY MOTOR CARRIER, A PROPER CHASSIS OR MODIFIED FLATBED TRAILER MUST BE USED TO PRECLUDE VIOLATION OF ONE OR MORE "WEIGHT LAWS" APPLICABLE TO THE STATE OR STATES INVOLVED.
- N. THE QUANTITY OF CONTAINERS SHOWN IN THE LOAD ON PAGE 2 MAY BE REDUCED FOR SHIPMENT, IF DESIRED. SEE THE "LESS-THAN-FULL-LOAD" DETAIL ON PAGE 7. WHEN A CONTAINER IS TO BE LOADED WITH A REDUCED QUANTITY OF LADING UNITS, THE LENGTHWISE CENTER OF GRAVITY OF THE LOAD MUST BE WITHIN 12", IN EITHER DIRECTION, OF THE MID-POINT OF THE CONTAINER.
- O. ANTI-CHAFING MATERIAL MAY BE INSTALLED AT POINTS OF CONTACT BETWEEN CONTAINERS AND THE SIDE OPENING CONTAINER, AND BETWEEN CONTAINERS AND STEEL STRAPPING, IF DESIRED, TO PREVENT CHAFING DAMAGE TO CONTAINER PAINT AND MARKINGS.
- P. RECOMMENDED SEQUENTIAL LOADING PROCEDURES:
 - 1. PREFABRICATE TWO END BLOCKING ASSEMBLIES, TWO CENTER FILL ASSEMBLIES, TWO CENTER GATES AND TWO SIDE FILL ASSEMBLIES.
 - 2. INSTALL ONE END BLOCKING ASSEMBLY.
 - 3. LOAD THREE CONTAINERS.
 - 4. INSTALL ONE CENTER FILL ASSEMBLY AND WIRE TIE.
 - 5. LOAD THREE CONTAINERS.
 - 6. REPEAT STEPS 2 THRU 5.
 - 7. INSTALL TWO CENTER GATES AND 12 STRUTS.
 - 8. INSTALL TWO SIDE FILL ASSEMBLIES AND WIRE TIE.

GENERAL NOTES

- A. THIS DOCUMENT HAS BEEN PREPARED AND ISSUED IN ACCORDANCE WITH AR 740-1 AND AUGMENTS TM 743-200-1 (CHAPTER 5).
- B. THE OUTLOADING PROCEDURES SPECIFIED IN THIS DRAWING ARE APPLICABLE TO LOADS OF CBU ITEMS PACKED IN CNU-80/E CONTAINERS AND MAU ITEMS INCLUDING MAU-157/B, MAU-157A/B, AND MAU-169/B PACKED IN CNU-203/E CONTAINERS. SUBSEQUENT REFERENCE TO CONTAINER HEREIN MEANS THE CONTAINER WITH CBU OR MAU ITEMS. SEE PAGE 4 FOR DETAILS OF THE CONTAINERS. CAUTION: REGARDLESS OF THE QUANTITY OF UNITS TO BE SHIPPED, THE "MAXIMUM GROSS WEIGHT" OF THE SIDE OPENING ISO CONTAINER MUST NOT BE EXCEEDED.
- C. THE LOADS AS SHOWN ARE BASED ON 6,050 POUND 20' LONG BY 8' WIDE BY 8'-6" HIGH SIDE OPENING ISO CONTAINER WITH INSIDE DIMENSIONS OF 19'-4" LONG BY 89" WIDE BY 88" HIGH AND A MAXIMUM GROSS WEIGHT OF 52,910 POUNDS. THE LOAD IS DESIGNED FOR TRAILER/CONTAINER-ON-FLATCAR (T/COFC) SHIPMENT, HOWEVER, THE LOAD AS DESIGNED CAN ALSO BE MOVED BY MOTOR OR WATER CARRIERS. NOTICE: OTHER CONTAINERS OF THE SAME DESIGN CONFIGURATION CAN ALSO BE USED.
- D. WHEN LOADING CONTAINERS, THEY ARE TO BE POSITIONED SO AS TO ACHIEVE A TIGHT LOAD (TIGHT AGAINST THE DUNNAGE ASSEMBLIES). THE UNBLOCKED SPACE ACROSS THE WIDTH OF A LOAD BAY IS NOT TO EXCEED 1-1/2". EXCESSIVE SLACK CAN BE ELIMINATED FROM A LOAD BY LAMINATING ADDITIONAL PIECES OF APPROPRIATE THICKNESS TO THE SIDE FILL ASSEMBLIES. NAIL EACH ADDITIONAL PIECE TO THE VERTICAL PIECE W/1 APPROPRIATELY SIZED NAIL EVERY 12". ADDITIONALLY, THE THICKNESS AND QUANTITY OF THE DUNNAGE LUMBER USED MAY BE ADJUSTED AS REQUIRED TO FACILITATE VARIANCE IN THE SIZE OF THE CONTAINER.
- E. DUNNAGE LUMBER SPECIFIED IS OF NOMINAL SIZE. FOR EXAMPLE, 1" X 6" MATERIAL IS ACTUALLY 3/4" THICK BY 5-1/2" WIDE AND 2" X 6" MATERIAL IS ACTUALLY 1-1/2" THICK BY 5-1/2" WIDE.
- F. A STAGGERED NAILING PATTERN WILL BE USED WHENEVER POSSIBLE WHEN NAILS ARE DRIVEN INTO JOINTS OF DUNNAGE ASSEMBLIES OR WHEN LAMINATING DUNNAGE. ADDITIONALLY, THE NAILING PATTERN FOR AN UPPER PIECE OF LAMINATED DUNNAGE WILL BE ADJUSTED AS REQUIRED SO THAT A NAIL FOR THAT PIECE WILL NOT BE DRIVEN THROUGH ONTO OR RIGHT BESIDE A NAIL IN A LOWER PIECE.
- G. IN SOME CONTAINERS THERE IS A SLOT AT THE CORNERS OF THE ENDWALLS. A PIECE OF DUNNAGE MATERIAL MUST BE LAMINATED TO THE VERTICAL PIECES OF THE END BLOCKING ASSEMBLY TO PROVIDE A FLAT SURFACE FOR THE 2" X 4" VERTICAL PIECES. A PIECE OF 2" X 4", 2" X 3", OR A SPECIAL WIDTH PIECE CUT-TO-FIT CAN BE USED. THIS FILL PIECE WILL BE NAILED WITH ONE APPROPRIATELY SIZED NAIL EVERY 12". THIS PIECE IS NOT REQUIRED WHEN THE ENDWALL OF THE CONTAINER IS SMOOTH AND FLAT.
- H. CAUTION: DO NOT NAIL DUNNAGE MATERIAL TO THE CONTAINER WALLS OR FLOOR. ALL NAILING WILL BE WITHIN THE DUNNAGE.
- J. PORTIONS OF THE CONTAINER DEPICTED WITHIN THIS DRAWING, SUCH AS THE SIDE DOORS, HAVE NOT BEEN SHOWN IN THE LOAD VIEW FOR CLARITY PURPOSES.

(CONTINUED AT LEFT)

MATERIAL SPECIFICATIONS

- LUMBER - - - - - : SEE TM 743-200-1 (DUNNAGE LUMBER) AND FED SPEC MM-L-751.
- NAILS - - - - - : FED SPEC FF-N-105; COMMON.
- STRAPPING, STEEL - - : ASTM D3953; FLAT STRAPPING, TYPE 1, HEAVY DUTY, FINISH A, B (GRADE 2), OR C.
- SEAL, STRAP - - - - - : ASTM D3953; CLASS H, FINISH A, B (GRADE 2), OR C, DOUBLE NOTCH TYPE, STYLE I, II, OR IV.
- WIRE, CARBON STEEL - : ASTM A853; ANNEALED AT FINISH, BLACK OXIDE FINISH, .0800" DIA, GRADE 1006 OR BETTER.
- ANTI-CHAFING MATERIAL - - - - - : MIL-B-121 (OR EQUAL); NEUTRAL BARRIER MATERIAL.

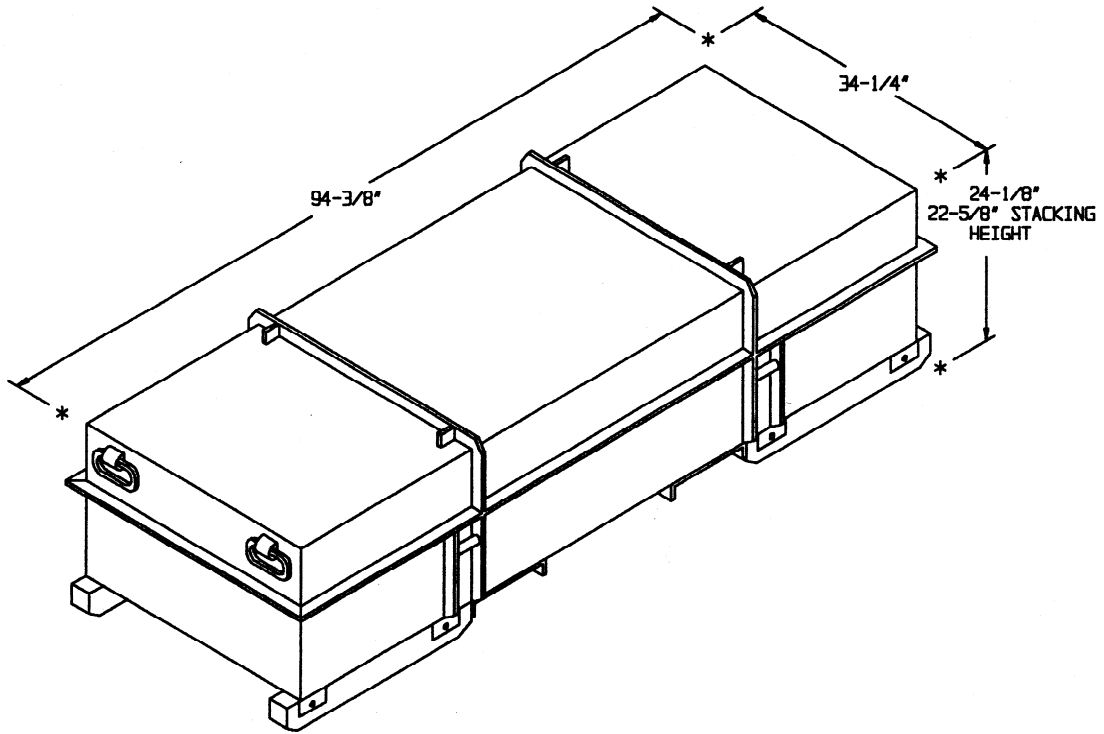

CNU-80/E OR CNU-203/E CONTAINER

CNU-80/E WEIGHT ----- 934 TO 1,174 LBS (APPROX)
 CNU-203/E WEIGHT ----- 850 LBS (APPROX)
 CUBE ----- 45.2 CUBIC FEET (APPROX)

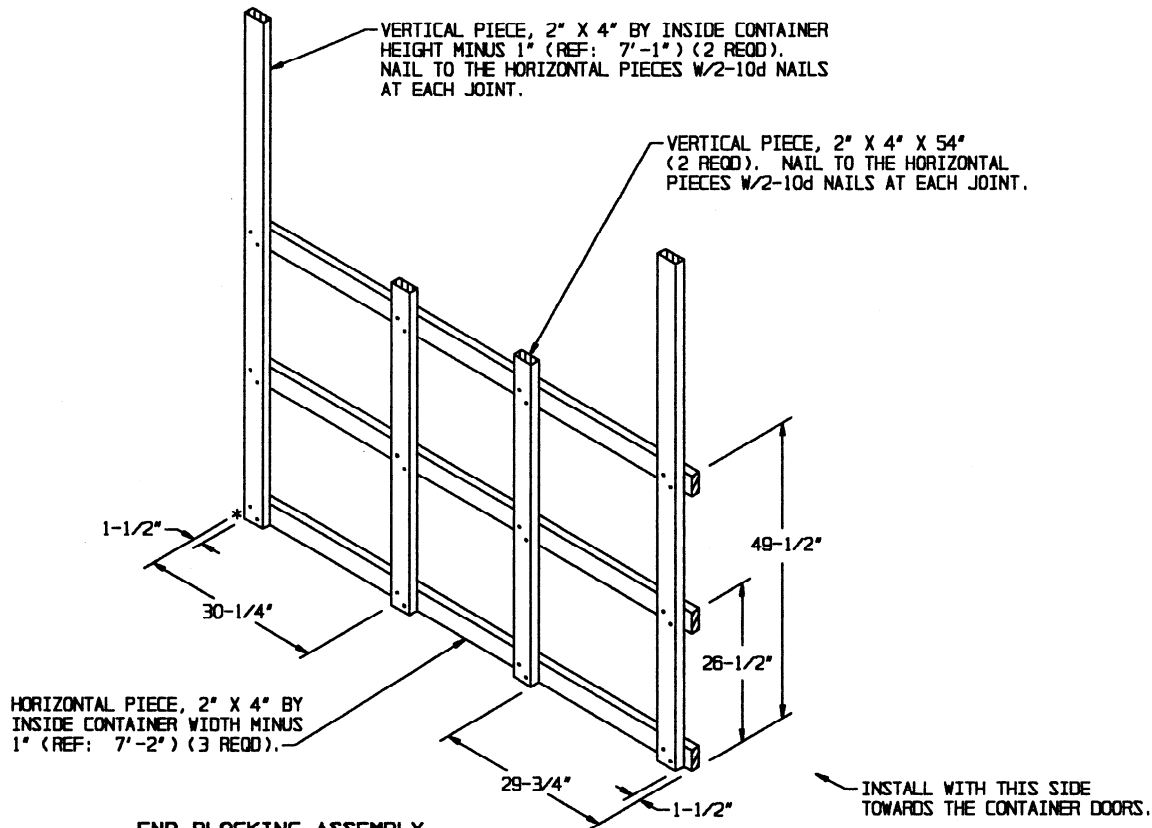

END BLOCKING ASSEMBLY

NOTE: FOR A TWO HIGH LOAD, ELIMINATE THE TOP HORIZONTAL PIECE, AND FOR A ONE HIGH LOAD, ELIMINATE THE TOP TWO HORIZONTAL PIECES. SHORTEN THE 54" VERTICAL PIECES APPROPRIATELY. A "LEFT HAND" ASSEMBLY IS DEPICTED ABOVE. A "RIGHT HAND" ASSEMBLY IS ALSO REQUIRED.

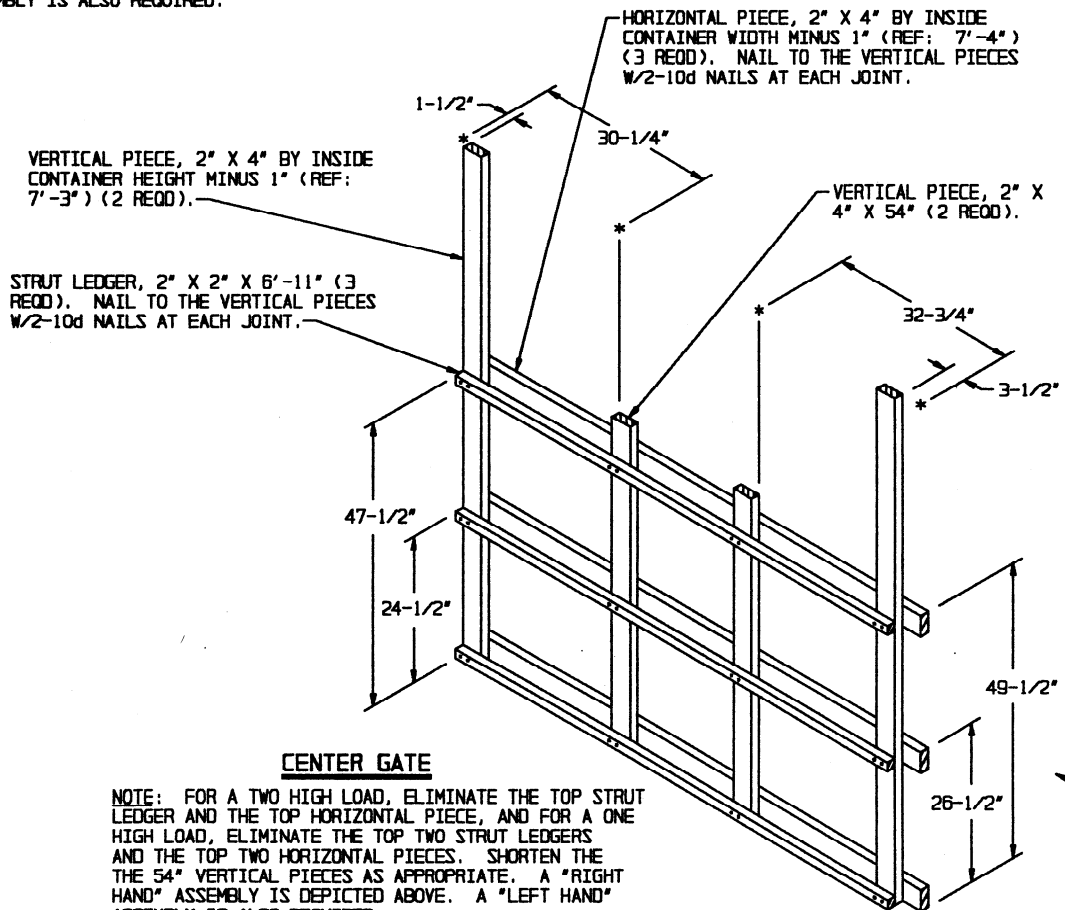

CENTER GATE

NOTE: FOR A TWO HIGH LOAD, ELIMINATE THE TOP STRUT LEDGER AND THE TOP HORIZONTAL PIECE, AND FOR A ONE HIGH LOAD, ELIMINATE THE TOP TWO STRUT LEDGERS AND THE TOP TWO HORIZONTAL PIECES. SHORTEN THE 54" VERTICAL PIECES AS APPROPRIATE. A "RIGHT HAND" ASSEMBLY IS DEPICTED ABOVE. A "LEFT HAND" ASSEMBLY IS ALSO REQUIRED.

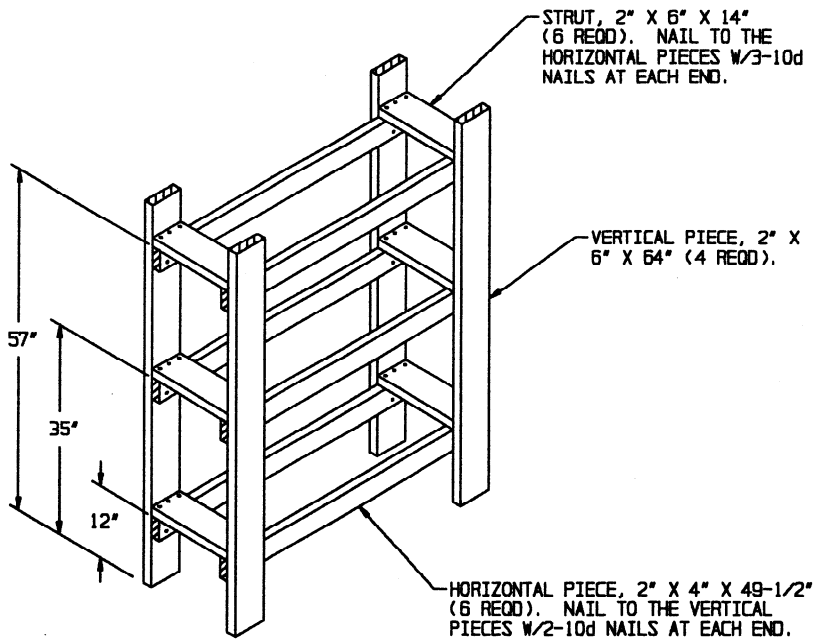

CENTER FILL ASSEMBLY

NOTE: FOR A TWO HIGH LOAD, ELIMINATE THE TOP TWO HORIZONTAL PIECES AND THE TOP TWO STRUTS, AND FOR A ONE HIGH LOAD, ELIMINATE THE TOP FOUR HORIZONTAL PIECES AND THE TOP FOUR STRUTS. SHORTEN THE VERTICAL PIECES APPROPRIATELY.

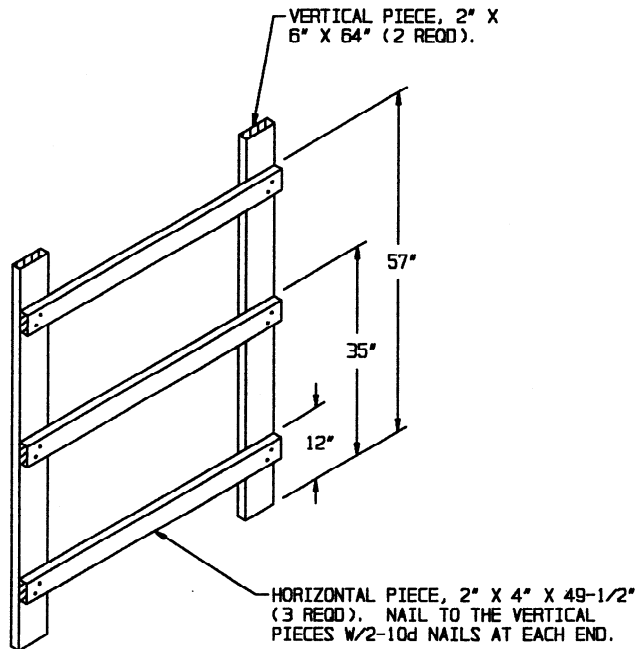

SIDE FILL ASSEMBLY

NOTE: FOR A TWO HIGH LOAD, ELIMINATE THE TOP HORIZONTAL PIECE, AND FOR A ONE HIGH LOAD, ELIMINATE THE TOP TWO HORIZONTAL PIECES. SHORTEN THE VERTICAL PIECES APPROPRIATELY.

UNITIZING STRAP, 1-1/4" X .035" OR .031" X 14'-3" LONG STEEL STRAPPING (2 REQD PER CONTAINER STACK). INSTALL TO ENCIRCLE THE TOP TWO CONTAINERS. SEAL WITH ONE SEAL CRIMPED WITH TWO PAIR OF NOTCHES OR WITH TWO SEALS, EACH CRIMPED WITH TWO PAIR OF CRIMPS.

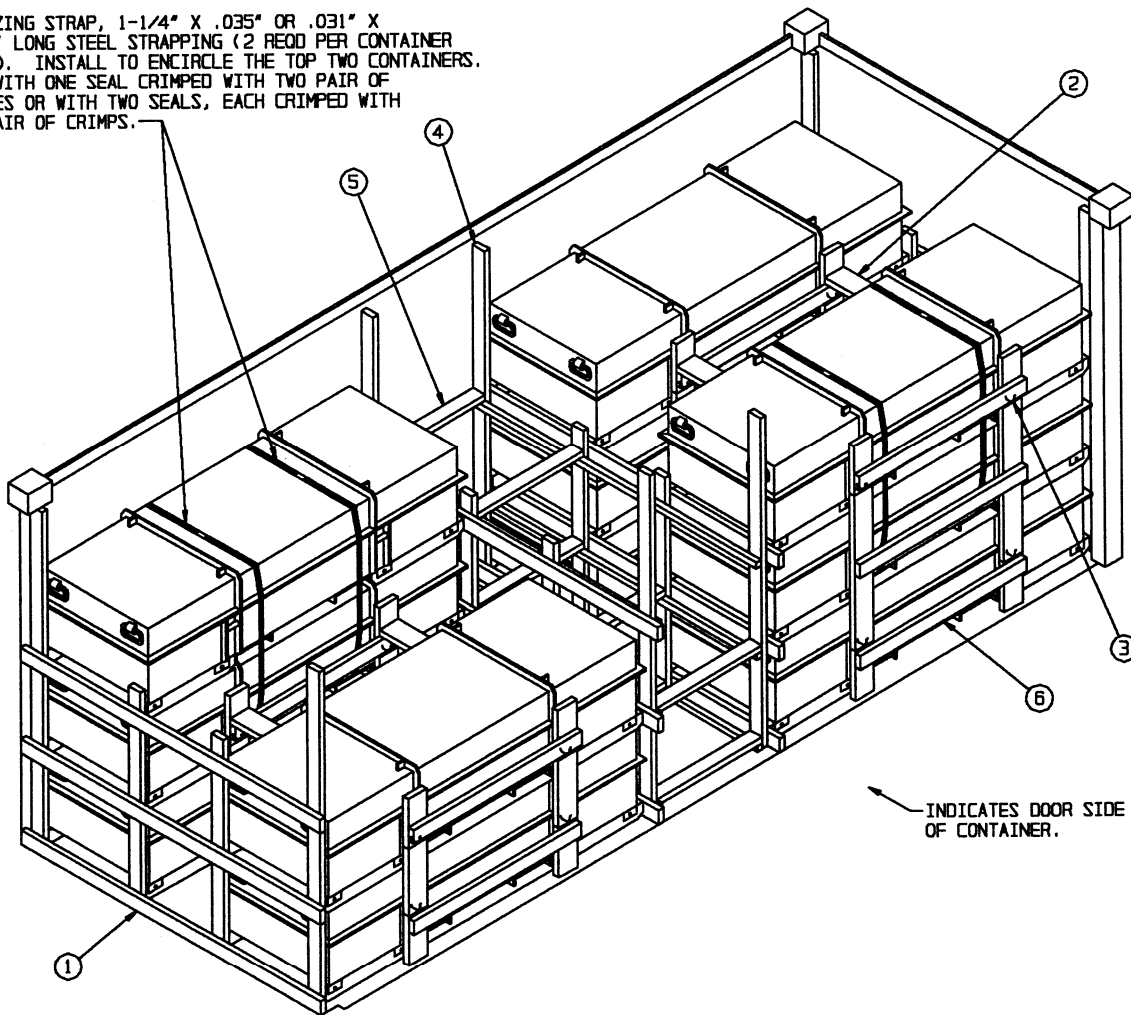

ISOMETRIC VIEW

SPECIAL NOTE:

WHEN REDUCING A LOAD BY ONE OR MORE CONTAINERS, IT WILL BE NECESSARY TO UNITIZE THE CONTAINER STACKS WHICH ARE LATERALLY AND LONGITUDINALLY ADJACENT TO THE OMITTED CONTAINER AS DEPICTED IN THE LOAD VIEW ABOVE. SEE GENERAL NOTES "N" AND "O" ON PAGE 3.

LESS-THAN-FULL-LOAD PROCEDURE

KEY NUMBERS REFER TO KEY NUMBERS ON PAGE 2. NOTE THAT CENTER AND SIDE FILL ASSEMBLIES HAVE BEEN MODIFIED AS DESCRIBED ON PAGE 6, AND THAT TWO STRUTS HAVE BEEN OMITTED.

