

APPROVED BY
BUREAU OF EXPLOSIVES

J. H. Fleishman

DATE 5/13/94

LOADING AND BRACING[●] IN MILVAN CONTAINERS[⊕] OF BLU-107/B (DURANDAL) WEAPONS IN CNU-381/E SHIPPING AND STORAGE CONTAINERS

INDEX

| <u>ITEM</u> | <u>PAGE(S)</u> |
|---|----------------|
| TYPICAL LOADING PROCEDURES - - - - - | 2 |
| GENERAL NOTES AND MATERIAL SPECIFICATIONS - - - - - | 3 |
| CNU-381/E CONTAINER DETAIL - - - - - | 4 |
| DETAILS - - - - - | 5 |
| LESS-THAN-FULL-LOAD DETAILS - - - - - | 6 |

● LOADING AND BRACING SPECIFICATIONS SET FORTH WITHIN THIS DRAWING ARE APPLICABLE TO LOADS THAT ARE TO BE SHIPPED BY TRAILER/CONTAINER-ON-FLATCAR (T/COFC) RAIL CARRIER SERVICE. THESE SPECIFICATIONS MAY ALSO BE USED FOR LOADS THAT ARE TO BE MOVED BY MOTOR OR WATER CARRIERS.

⊕ ONLY MILVAN CONTAINERS WHICH HAVE BEEN MODIFIED TO INCLUDE A MECHANICAL LOAD-BRACING SYSTEM THAT SATISFIES THE REQUIREMENTS OF THE BUREAU OF EXPLOSIVES PAMPHLET 6C WILL BE USED FOR THE MOVEMENT OF AMMUNITION BY T/COFC SERVICE. CAUTION: OTHER REQUIREMENTS OF PAMPHLET 6C ALSO APPLY.

U.S. ARMY MATERIEL COMMAND DRAWING

APPROVED, U.S. ARMY ARMAMENT, MUNITIONS AND
CHEMICAL COMMAND
John E. Hahn

| | | |
|-----------|------------|------------|
| DRAFTSMAN | TECHNICIAN | ENGINEER |
| | | L. FIEFFER |

APPROVED BY ORDER OF COMMANDING GENERAL, U.S.
ARMY MATERIEL COMMAND
John L. Byrd Jr.
U.S. ARMY DEFENSE AMMUNITION CENTER AND SCHOOL

| | | |
|---------------------------------------|---|------------------------------------|
| VALIDATION ENGINEERING DIVISION | TRANSPORTATION ENGINEERING DIVISION | LOGISTICS ENGINEERING OFFICE |
| <i>JHK</i> | <i>W. Frenick</i> | <i>W. Ernst</i> |

DECEMBER 1993

DO NOT SCALE

| | | | |
|-------|----------|---------|---------|
| CLASS | DIVISION | DRAWING | FILE |
| 19 | 48 | 8528 | SP15J28 |

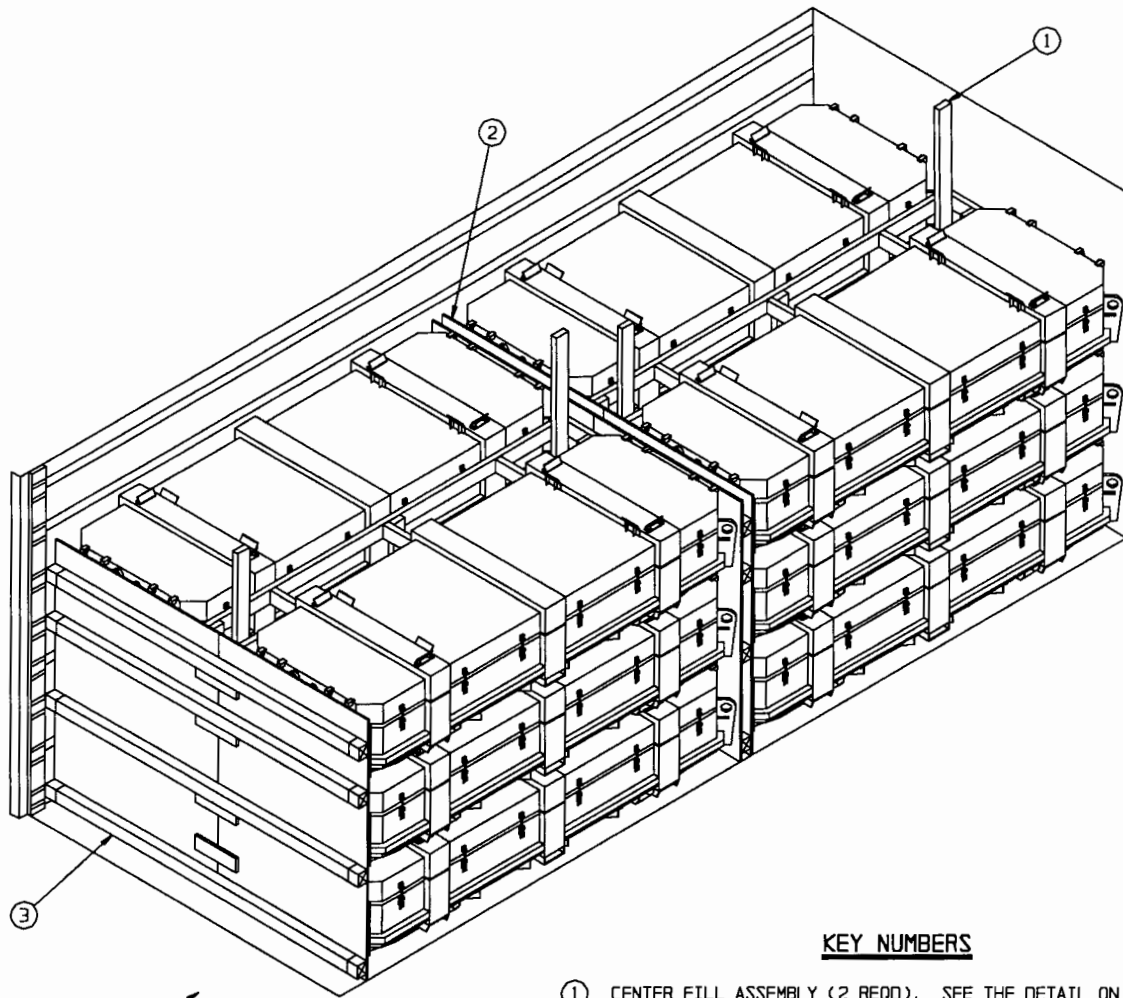

REAR OF CONTAINER. →

ISOMETRIC VIEW

KEY NUMBERS

- ① CENTER FILL ASSEMBLY (2 REQD). SEE THE DETAIL ON PAGE 5.
- ② SEPARATOR GATE (3 REQD). SEE THE DETAIL ON PAGE 5.
- ③ CROSS MEMBER (8 REQD). POSITION AS SHOWN IN THE DETAIL ABOVE, AT THE 5", 28", 48" AND 60" HEIGHTS. SEE THE "FILL DETAIL" ON PAGE 4.

BILL OF MATERIAL

| LUMBER | LINEAR FEET | BOARD FEET |
|---------------|-------------------|------------|
| 1" X 4" | 12 | 4 |
| 1" X 6" | 6 | 3 |
| 2" X 4" | 188 | 126 |
| NAILS | NO. REQD | POUNDS |
| 6d (2") | 90 | 3/4 |
| 10d (3") | 192 | 3 |
| PLYWOOD, 1/2" | 123.75 SQ FT REQD | 170.16 LBS |
| CROSS MEMBER | 8 REQD | |

LOAD AS SHOWN

| ITEM | QUANTITY | WEIGHT (APPROX) |
|--------------|----------|---------------------|
| CNU-381/E | 12 | 24,600 LBS |
| DUNNAGE | | 440 LBS |
| CONTAINER | | 5,700 LBS |
| TOTAL WEIGHT | | 30,740 LBS (APPROX) |

K. TO MAKE LOADING EASIER, TO HELP ACHIEVE A TIGHT LOAD ACROSS A CONTAINER, AND TO PREVENT UNACCEPTABLE DAMAGE TO LADING UNITS WHEN LOADING A MILVAN, A SLIP-SHEET CAN BE USED EFFECTIVELY AS A "SHOEHORN" TYPE DEVICE. THE SLIP-SHEET WILL PROVIDE A SMOOTH SURFACE THAT WILL PREVENT CONTAINERS FROM INTERLOCKING OR CATCHING ON OTHER PROJECTIONS WHEN LATERALLY ADJACENT LADING UNITS ARE BEING LOADED. A SLIP-SHEET WILL BE USED AFTER ONE-HALF OF A STACK IS LOADED WITH ONE OF ITS SIDES IN TIGHT CONTACT AT ONE SIDE OF THE MILVAN. THE SLIP-SHEET IS TO BE PLACED AGAINST THE OTHER SIDE OF THE HALF-STACK BEFORE THE LAST HALF OF THE STACK IS LOADED. AFTER A STACK IS COMPLETED, THE SLIP-SHEET IS TO BE REMOVED FOR SUBSEQUENT USE WITH THE NEXT STACK. A SLIP-SHEET OF SUITABLE SIZE CAN BE MADE FROM A SHEET OF 1/8" TEMPERED HARDBOARD (MASONITE) OR FROM A SHEET OF ANY OTHER MATERIAL THAT WILL SATISFY THE REQUIREMENTS.

L. MAXIMUM LOAD WEIGHT CRITERIA:

THE ITEMIZED LOAD WEIGHTS ARE CONTROLLED BY EQUIPMENT CAPABILITY FACTORS. ALSO, THESE LISTED LOAD WEIGHTS IDENTIFY THE COMBINED WEIGHT OF AMMUNITION LADING UNITS AND DUNNAGE THAT CAN BE PLACED INTO ONE MILVAN CONTAINER WITHOUT VIOLATING ONE OR MORE OF THE "CAPABILITY FACTORS". SEE NOTES 1 AND 2.

39,100 LBS IN 20-FT CONTAINER (W/O CHASSIS) ABOARD CONTAINERSHIP.

39,100 LBS IN CONTAINER ON 20-FT CHASSIS WITH DOUBLE BOGIE. SEE NOTE 3.

25,300 LBS IN CONTAINER ON 20-FT CHASSIS WITH SINGLE BOGIE. SEE NOTE 4.

21,300 LBS IN EACH CONTAINER ON 40-FT CHASSIS (COUPLED WITH DOUBLE BOGIE). SEE NOTE 3.

NOTE 1: DUNNAGE INCLUDES MATERIALS, OTHER THAN COMPONENTS OF THE MECHANICAL LOAD BRACING SYSTEM, USED TO BLOCK AND BRACE A LOAD.

NOTE 2: ALTHOUGH THE HEAVIEST MAXIMUM LOADS ARE DELINEATED IN THE LOAD VIEWS, PROVISIONS ARE INCLUDED WITHIN THIS DRAWING SO THAT THE BASIC LOADS CAN BE ADJUSTED TO SATISFY A LESSER QUANTITY OF LADING UNITS.

NOTE 3: DEPENDING ON TRANSPORTATION ROUTING, IT MAY BE NECESSARY TO REDUCE THE LOAD WEIGHT TO SATISFY "WEIGHT LAWS" OF CERTAIN STATES. ALSO, IT MAY BE NECESSARY TO REDUCE THE LOAD WEIGHT TO SATISFY OTHER WEIGHT RESTRICTIONS IMPOSED ON THE MILVAN SYSTEM.

NOTE 4: BY SPECIAL AUTHORITY, IT MAY BE POSSIBLE TO MOVE HEAVIER LOADS ON SINGLE BOGIE CHASSIS WITHIN AN INSTALLATION.

M. SPECIAL T/COFC NOTES:

1. CAUTION: LOADED CONTAINERS MUST BE ON CHASSIS EQUIPPED WITH TWO BOGIE ASSEMBLIES WHEN BEING MOVED IN TOFC SERVICE, REGARDLESS OF THE LOAD WEIGHT WITHIN THE CONTAINER.

2. LOAD LIMITS OF T/COFC RAIL CARS MUST NOT BE EXCEEDED, NOR WILL A CAR BE LOADED SO THAT THE TRUCK UNDER ONE END OF THE CAR CARRIES MORE THAN ONE-HALF OF THE LOAD LIMIT FOR THAT CAR.

3. CHASSIS/CONTAINERS COUPLED INTO A 40-FOOT TRAILER CONFIGURATION MUST BE PLACED AT THE B-END OF A TOFC RAIL CAR. THE REAR END OF THE 40-FOOT UNIT WILL OVERHANG THE END OF THE CAR IF IT IS PLACED AT THE A-END. TWENTY-FOOT AND 40-FOOT UNITS CAN BE LOADED ON THE SAME CAR.

N. WHEN LOADING CONTAINERS, THEY ARE TO BE POSITIONED SO AS TO ACHIEVE A TIGHT LOAD LATERALLY AND LONGITUDINALLY WITHIN THE MILVAN. ALTHOUGH A TOTAL OF 1-1/2" OF UNBLOCKED SPACE ACROSS THE WIDTH OF A LOAD BAY IS PERMITTED, LONGITUDINAL VOIDS WITHIN THE LOAD ARE TO BE KEPT TO A MINIMUM. ADJUSTMENTS CAN BE MADE BY LAMINATING ADDITIONAL PIECES OF APPROPRIATE THICKNESS TO THE LONGITUDINAL PIECES ON THE CENTER GATES. NAIL EACH ADDITIONAL PIECE TO THE LONGITUDINAL PIECE W/1 APPROPRIATELY SIZED NAIL EVERY 12". ADDITIONALLY, THE LENGTH OF THE LATERAL AND STIFFENER PIECES IN THE CENTER GATE MAY BE ADJUSTED, AS NECESSARY, TO FACILITATE VARIANCE IN THE CONTAINER SIZE.

O. THE QUANTITY OF CONTAINERS SHOWN IN THE LOAD ON PAGE 2 MAY BE REDUCED FOR SHIPMENT, IF DESIRED. SEE THE LESS-THAN-FULL-LOAD DETAILS ON PAGE 6. WHEN A MILVAN IS TO BE LOADED WITH A REDUCED QUANTITY OF LADING UNITS, THE LENGTHWISE CENTER OF GRAVITY OF THE LOAD MUST BE WITHIN 12", IN EITHER DIRECTION, OF THE MID-POINT OF THE MILVAN.

A. THIS DOCUMENT HAS BEEN PREPARED AND ISSUED IN ACCORDANCE WITH AR 740-1 AND AUGMENTS TM 743-200-1 (CHAPTER 5).

B. THE SPECIFIED OUTLOADING PROCEDURES ARE APPLICABLE TO LOADS OF BLU-107/B (DURANDAL) WEAPONS PACKED IN CNU-381/E CONTAINERS. SUBSEQUENT REFERENCE TO CONTAINER HEREIN MEANS THE CNU-381/E CONTAINER WITH BOMBS INSTALLED. SEE PAGE 4 FOR DETAILS OF THE CONTAINER. CAUTION: REGARDLESS OF THE QUANTITY OF UNITS TO BE SHIPPED, THE "MAXIMUM GROSS WEIGHT" OF THE MILVAN MUST NOT BE EXCEEDED.

C. THE LOADS AS SHOWN ARE BASED ON A 20' LONG BY 8' WIDE BY 8' HIGH MILVAN CONTAINER WITH INSIDE DIMENSIONS OF 19'-4" LONG BY 92" WIDE BY 87" HIGH. THE LOADS ARE DESIGNED FOR TRAILER/CONTAINER-ON-FLATCAR (T/COFC) SHIPMENT.

D. THE SPECIFIED OUTLOADING PROCEDURES ARE FOR CONTAINERS EQUIPPED WITH SELF-CONTAINED MECHANICAL BRACING DEVICES AS DESCRIBED WITHIN BUREAU OF EXPLOSIVES PAMPHLET 6C. CROSS MEMBER ATTACHMENT FACILITIES WITHIN THESE CONTAINERS MUST PROVIDE FOR THE INSTALLATION OF LOAD BLOCKING CROSS MEMBERS AT THE HEIGHTS SPECIFIED. THE WEIGHT DIMENSIONS SPECIFIED WITHIN THIS DRAWING FOR THE INSTALLATION OF CROSS MEMBERS CONFORM WITH THE BUREAU OF EXPLOSIVES PAMPHLET 6C, WITH THE EXCEPTION THAT TWO ADDITIONAL BELT RAILS HAVE BEEN SHOWN: ONE AT 72" AND ONE AT 83" HIGH FROM THE CONTAINER FLOOR. VOIDS LENGTHWISE WITHIN THE LOAD MUST BE HELD TO A MINIMUM. CROSS MEMBERS MUST BE PLACED AGAINST THE LADING AS TIGHTLY AS THE HOLE SPACING IN THE CROSS MEMBER ATTACHMENT FACILITY PERMITS. EACH CROSS MEMBER WILL BE INSTALLED WITH THE ENDS ATTACHED AS NEARLY AS POSSIBLE IN "MATED" POSITIONS (AT EQUAL HEIGHT AND AT EQUAL DISTANCES FROM THE END OF THE CONTAINER). CROSS MEMBERS IN EMPTY CONTAINERS AND THOSE NOT USED IN LOADED CONTAINERS MUST BE FASTENED INTO BELT RAILS FOR SHIPMENT. COMPONENTS ASSIGNED TO EACH CONTAINER MUST REMAIN THEREWITH EVEN THOUGH UNUSED DURING SOME SHIPMENTS. SEE THE "FILL DETAIL" ON PAGE 4 FOR THE DUNNAGING METHOD REQUIRED TO ELIMINATE AN EXCESSIVE LENGTHWISE VOID WITHIN A LOAD. THE LOAD BLOCKING COMPONENT DESIGNATED AS "CROSS MEMBER" HEREIN, IS IDENTIFIED AS "BEAM ASSEMBLY" WITHIN TM 55-8115-200-23 & P. DATED DECEMBER 1979. THE BEAM ASSEMBLY IS FURTHER IDENTIFIED AS NSN 8115-00-165-6623.

E. DUNNAGE LUMBER SPECIFIED IS OF A NOMINAL SIZE. FOR EXAMPLE, 1" X 4" MATERIAL IS ACTUALLY 3/4" THICK BY 3-1/2" WIDE AND 2" X 6" MATERIAL IS ACTUALLY 1 1/2" THICK BY 5-1/2" WIDE.

F. CAUTION: DO NOT NAIL DUNNAGE MATERIAL TO THE CONTAINER WALLS OR FLOOR. ALL NAILING WILL BE WITHIN THE DUNNAGE.

G. A STAGGERED NAILING PATTERN WILL BE USED WHENEVER POSSIBLE WHEN NAILS ARE DRIVEN INTO JOINTS OF DUNNAGE ASSEMBLIES OR WHEN LAMINATING DUNNAGE. ADDITIONALLY, THE NAILING PATTERN FOR AN UPPER PIECE OF LAMINATED DUNNAGE WILL BE ADJUSTED AS REQUIRED SO THAT A NAIL FOR THAT PIECE WILL NOT BE DRIVEN THROUGH ONTO OR RIGHT BESIDE A NAIL IN A LOWER PIECE.

H. PORTIONS OF THE CONTAINER DEPICTED WITHIN THIS DRAWING, SUCH AS ONE OF THE SIDEWALLS, HAVE NOT BEEN SHOWN IN THE LOAD VIEWS FOR CLARITY PURPOSES.

J. CONVERSION TO METRIC EQUIVALENTS: DIMENSIONS WITHIN THIS DOCUMENT ARE EXPRESSED IN INCHES, AND WEIGHTS ARE EXPRESSED IN POUNDS. WHEN NECESSARY, THE METRIC EQUIVALENTS MAY BE COMPUTED ON THE BASIS OF ONE INCH EQUALS 25.4MM AND ONE POUND EQUALS 0.454 KG.

(CONTINUED AT RIGHT)

MATERIAL SPECIFICATIONS

LUMBER - - - - - : SEE TM 743-200-1 (DUNNAGE LUMBER) AND FED SPEC MM-L-751.

NAILS - - - - - : FED SPEC FF-N-105; COMMON.

PLYWOOD - - - - - : COMMERCIAL ITEM DESCRIPTION A-A-55057, TYPE A, CONSTRUCTION AND INDUSTRIAL PLYWOOD, INTERIOR WITH EXTERIOR GLUE, GRADE C-D. IF SPECIFIED GRADE IS NOT AVAILABLE, A BETTER INTERIOR OR AN EXTERIOR GRADE MAY BE SUBSTITUTED.

STRAPPING, STEEL - - : ASTM D3953; FLAT STRAPPING, TYPE 1, HEAVY DUTY, FINISH A, B (GRADE 2), OR C.

SEAL, STRAP - - - - : ASTM D3953; CLASS H, FINISH A, B (GRADE 2), OR C, DOUBLE NOTCH TYPE, STYLE I, II, OR IV.

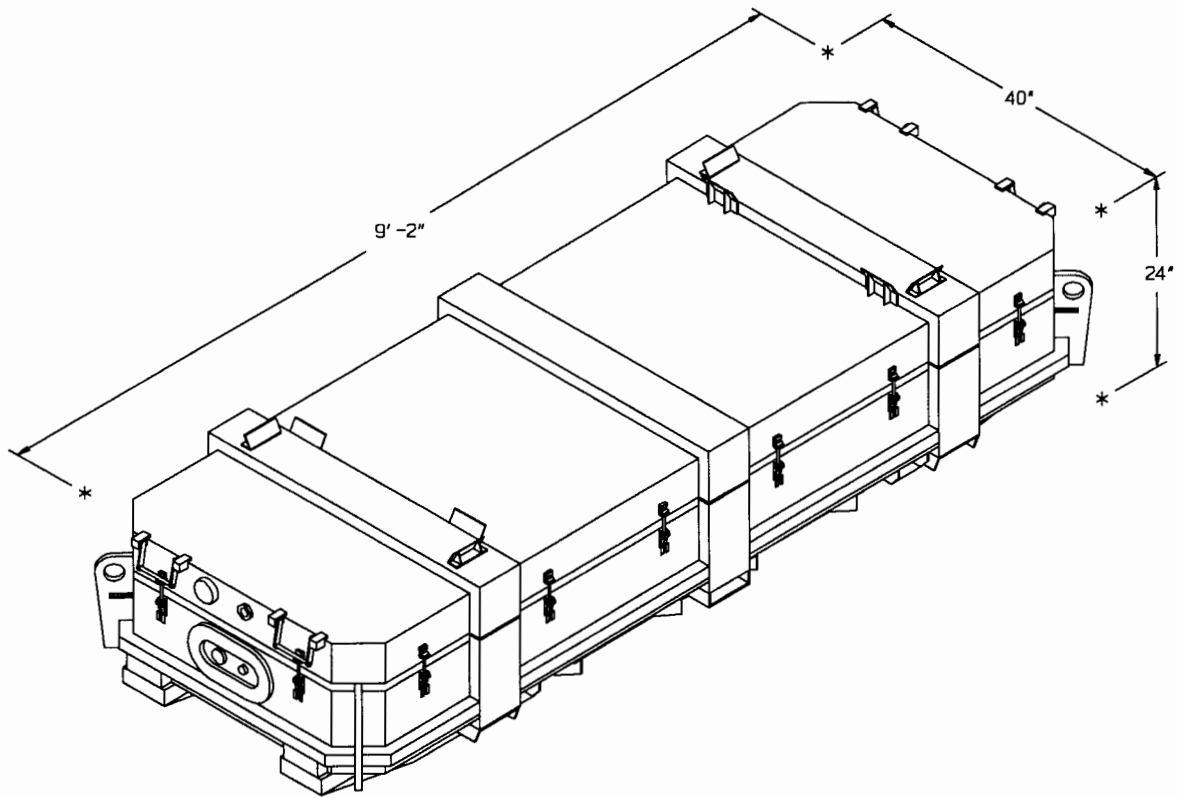

CNU-381/E CONTAINER

GROSS WEIGHT ----- 2,050 LBS (APPROX)
 CUBE ----- 61.1 CU FT (APPROX)

FILL MATERIAL, 1" X 4" OR
 2" X 4" MATERIAL BY CONTAINER
 WIDTH MINUS 1" (AS REQD).

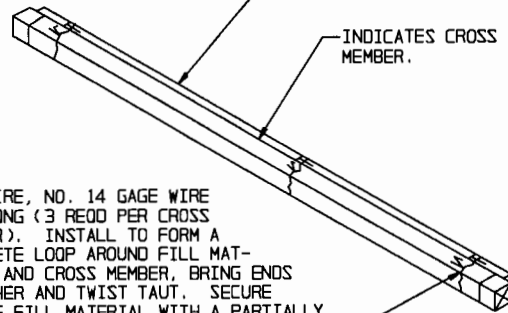

FILL DETAIL

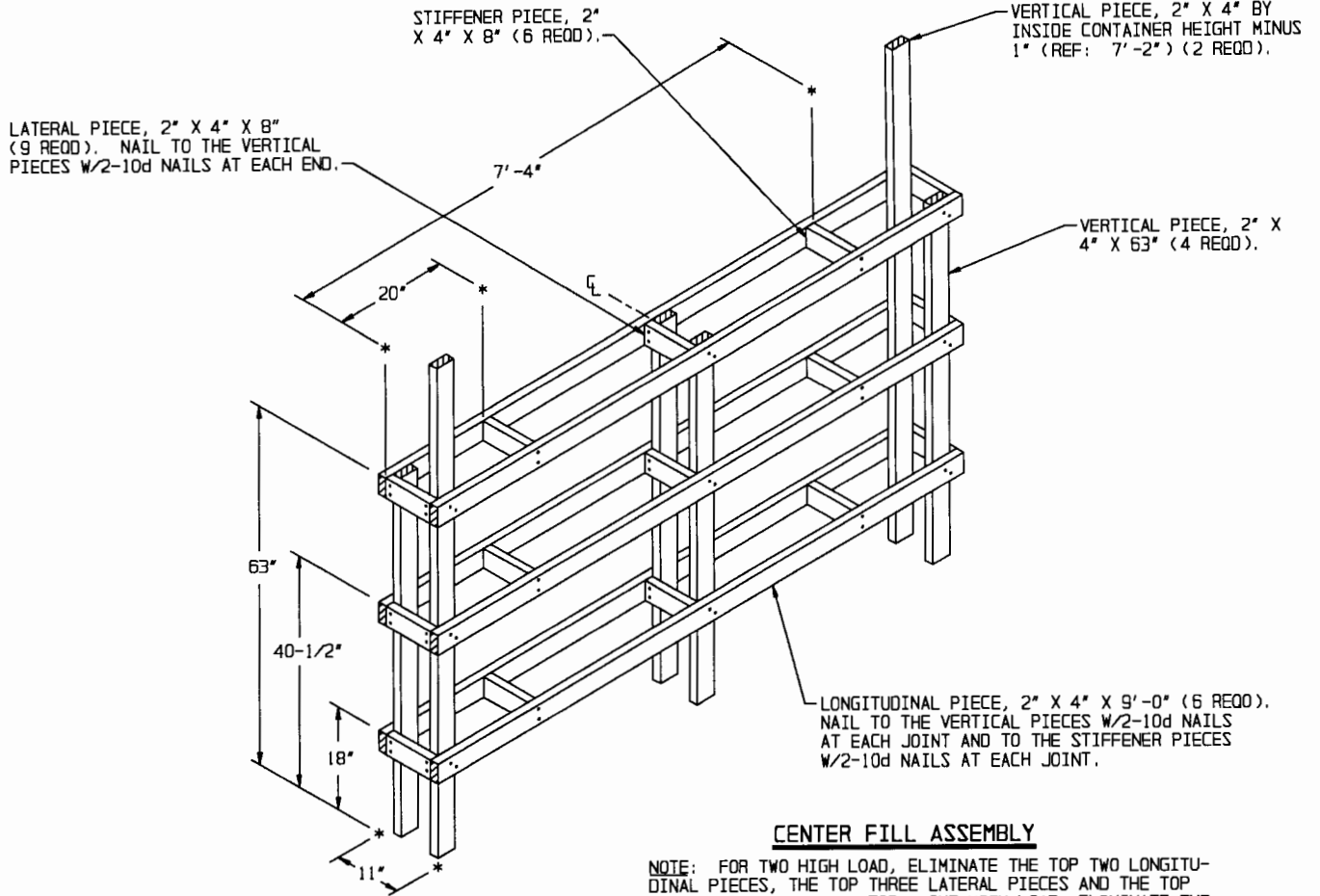

CENTER FILL ASSEMBLY

NOTE: FOR TWO HIGH LOAD, ELIMINATE THE TOP TWO LONGITUDINAL PIECES, THE TOP THREE LATERAL PIECES AND THE TOP TWO STIFFNER PIECES. FOR A ONE HIGH LOAD, ELIMINATE THE TOP FOUR LONGITUDINAL PIECES, THE TOP SIX LATERAL PIECES AND THE TOP FOUR STIFFNER PIECES. SHORTEN THE 63" VERTICAL PIECES APPROPRIATELY. THE LENGTH OF THE LATERAL AND STIFFNER PIECES IS DEPENDENT ON THE VOID AT THE CENTER OF THE LOAD.

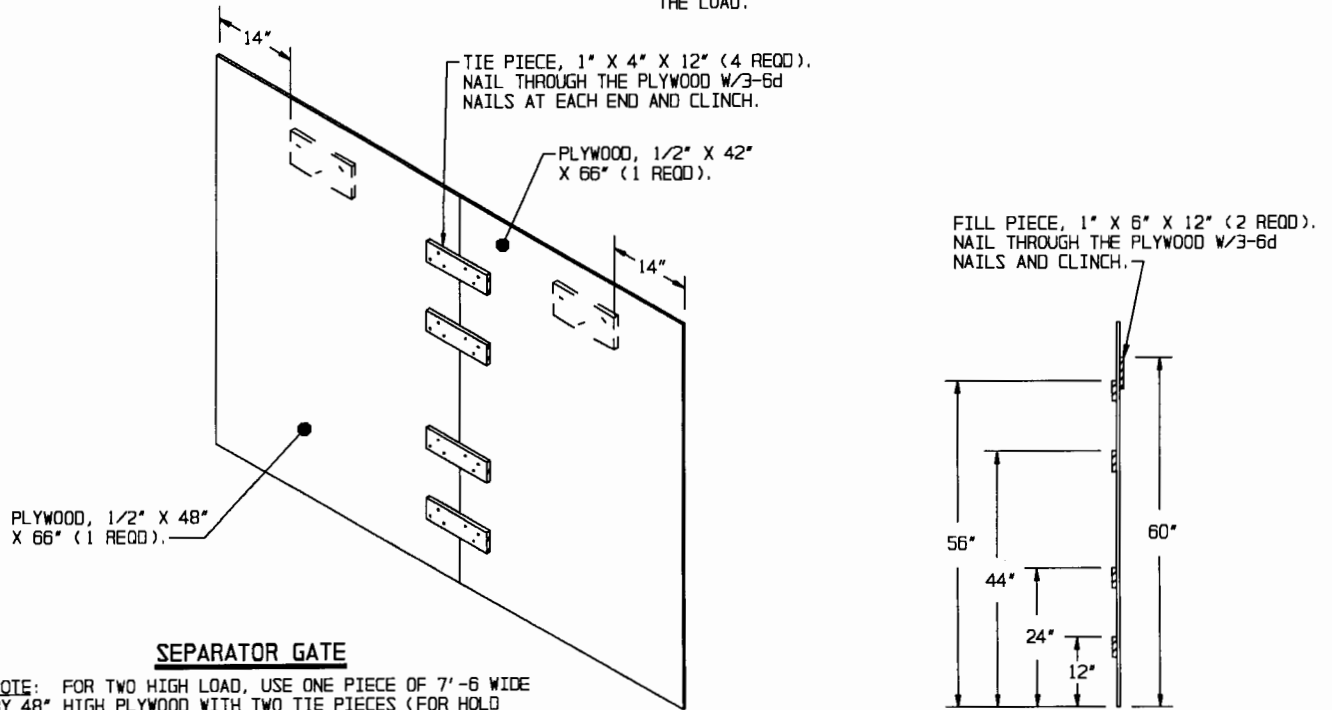

SEPARATOR GATE

NOTE: FOR TWO HIGH LOAD, USE ONE PIECE OF 7'-6" WIDE BY 48" HIGH PLYWOOD WITH TWO TIE PIECES (FOR HOLD DOWN) AND TWO FILL PIECES. FOR A ONE HIGH LOAD, USE ONE PIECE OF 7'-6" WIDE BY 24" HIGH PLYWOOD WITH TWO TIE PIECES (FOR HOLD DOWN) AND TWO FILL PIECES.

END VIEW

UNITIZING STRAP, 1-1/4" X .031" OR .035" BY LENGTH REQUIRED (2 REQD PER CONTAINER STACK). INSTALL TO ENCIRCLE THE TOP TWO CONTAINERS.

SEAL FOR 1-1/4" STRAPPING (1 REQD PER STRAP). CRIMP EACH SEAL WITH TWO PAIR OF NOTCHES.

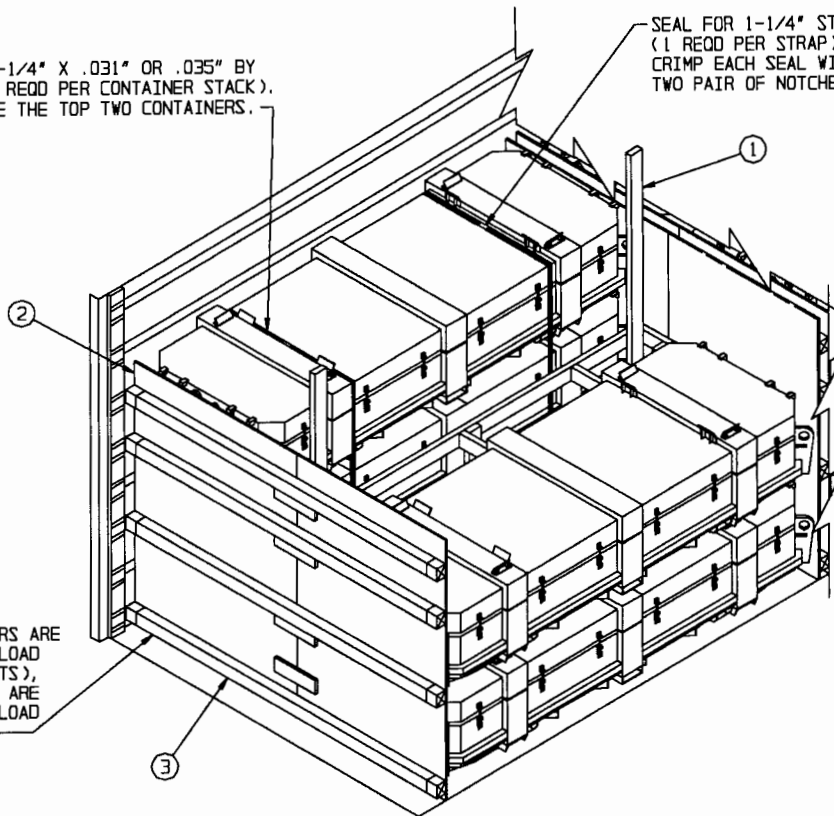

NOTE: SIX CROSS MEMBERS ARE NEEDED FOR A TWO HIGH LOAD (5', 28" AND 48" HEIGHTS), AND FOUR CROSS MEMBERS ARE NEEDED FOR A ONE HIGH LOAD (5' AND 16" HEIGHTS).

LESS-THAN-FULL-LOAD PROCEDURE

THE DETAIL ABOVE DEPICTS A BLOCKING METHOD TO BE USED IN A LESS-THAN-FULL CONTAINER LOAD (LESS THAN 12 UNITS). KEY NUMBERS REFER TO KEY NUMBERS ON PAGE 2. WHEN REDUCING A LOAD BY ONE OR MORE CONTAINERS IT WILL BE NECESSARY TO UNITIZE THE CONTAINER STACKS WHICH ARE LATERALLY ADJACENT TO THE OMITTED CONTAINER AS DEPICTED IN THE LOAD VIEW ABOVE. SEE GENERAL NOTE "0" ON PAGE 3.