

APPROVED BY
BUREAU OF EXPLOSIVES

J R Hardy

DATE 1-11-96

LOADING AND BRACING WITH WOODEN DUNNAGE ON FLATRACK ISO CONTAINERS OF CBU ITEMS PACKED IN CNU-80/E CONTAINERS AND/OR MAU ITEMS PACKED IN CNU-203/E CONTAINERS

INDEX

<u>ITEM</u>	<u>PAGE(S)</u>
GENERAL NOTES AND MATERIAL SPECIFICATIONS - - - - -	2
CONTAINER DETAIL - - - - -	3
TYPICAL LOADING PROCEDURES - - - - -	4,5
DETAILS - - - - -	6-8

- LOADING AND BRACING SPECIFICATIONS SET FORTH WITHIN THIS DRAWING ARE APPLICABLE TO LOADS THAT ARE TO BE SHIPPED BY TRAILER/CONTAINER-ON-FLATCAR (T/COFC) RAIL CARRIER SERVICE. THESE SPECIFICATIONS MAY ALSO BE USED FOR LOADS THAT ARE TO BE MOVED BY MOTOR OR WATER CARRIERS.

U.S. ARMY MATERIEL COMMAND DRAWING			
<small>APPROVED, U.S. ARMY INDUSTRIAL OPERATIONS COMMAND</small> <i>Donald E. Staebwick</i>	<small>DRAFTSMAN</small>	<small>TECHNICIAN</small>	<small>ENGINEER</small> L. FIEFFER
<small>APPROVED BY ORDER OF COMMANDING GENERAL, U.S. ARMY MATERIEL COMMAND</small> <i>Sam W. Collins</i>	<small>VALIDATION ENGINEERING DIVISION</small>	<small>TRANSPORTATION ENGINEERING DIVISION</small> <i>Sam W. Collins</i>	<small>LOGISTICS ENGINEERING OFFICE</small> <i>J. J. Michel</i>
<small>U.S. ARMY DEFENSE AMMUNITION CENTER AND SCHOOL</small> FEBRUARY 1996			
	<small>CLASS</small>	<small>DIVISION</small>	<small>DRAWING</small>
	19	48	8511
			<small>FILE</small>
			SP15J66

DO NOT SCALE

GENERAL NOTES

(GENERAL NOTES CONTINUED)

- A. THIS DOCUMENT HAS BEEN PREPARED AND ISSUED IN ACCORDANCE WITH AR 740-1 AND AUGMENTS TM 743-200-1 (CHAPTER 5).
- B. ALL LOADS SHIPPED BY THE PROCEDURES DEPICTED IN THIS DRAWING MUST BE IN ACCORDANCE WITH THE REQUIREMENTS SET FORTH IN TITLE 49, THE UNITED STATES CODE OF FEDERAL REGULATIONS; AR 55-355/AFM 75-2; DOD 4500.32-R; DOD 5100.76-M; DOD 6055.9-STD; AS WELL AS ANY AND ALL OTHER APPLICABLE SERVICE REGULATIONS.
- C. THE SPECIFIED OUTLOADING PROCEDURES ARE APPLICABLE TO LOADS OF CBU ITEMS PACKED IN CNU-80/E CONTAINERS AND MAU ITEMS INCLUDING MAU-157/B, MAU-157A/B, AND MAU-169/B PACKED IN CNU-203/E CONTAINERS. SUBSEQUENT REFERENCE TO CONTAINER HEREIN MEANS THE CONTAINER WITH CBU OR MAU ITEMS. SEE PAGE 3 FOR DETAILS OF THE CONTAINER. CAUTION: REGARDLESS OF THE QUANTITY OF CONTAINERS TO BE SHIPPED, THE "MAXIMUM GROSS WEIGHT" OF THE FLATRACK ISO CONTAINER MUST NOT BE EXCEEDED.
- D. THE LOAD AS SHOWN IS BASED ON A 20'-0" LONG BY 8'-0" WIDE FLATRACK ISO CONTAINER WITH FULL HEIGHT ENDWALLS, AND INSIDE DIMENSIONS OF 19'-4" LONG BY 7'-2" WIDE. THE LOAD AS SHOWN CAN BE SHIPPED BY ANY FORM OF SURFACE TRANSPORTATION. NOTICE: OTHER CONTAINERS OF THE SAME DESIGN CONFIGURATION CAN ALSO BE USED.
- E. WHEN LOADING CONTAINERS, THEY ARE TO BE POSITIONED SO AS TO ACHIEVE A TIGHT LOAD BETWEEN THE END BLOCKING ASSEMBLY AND THE LADING. ALTHOUGH A TOTAL OF 1" OF UNBLOCKED SPACE ACROSS THE WIDTH OF A LOAD IS PERMITTED, LONGITUDINAL VOIDS WITHIN THE LOAD ARE TO BE HELD TO A MINIMUM, NOT EXCEEDING 1/2". EXCESSIVE SLACK CAN BE ELIMINATED FROM A LOAD BY LENGTHENING THE STRUTS.
- F. DUNNAGE LUMBER SPECIFIED IS OF NOMINAL SIZE. FOR EXAMPLE, 1" X 4" MATERIAL IS ACTUALLY 3/4" THICK BY 3-1/2" WIDE AND 2" X 6" MATERIAL IS ACTUALLY 1-1/2" THICK BY 5-1/2" WIDE.
- G. A STAGGERED NAILING PATTERN WILL BE USED WHENEVER POSSIBLE WHEN NAILS ARE DRIVEN INTO JOINTS OF DUNNAGE ASSEMBLIES OR WHEN LAMINATING DUNNAGE. ADDITIONALLY, THE NAILING PATTERN FOR AN UPPER PIECE OF LAMINATED DUNNAGE WILL BE ADJUSTED AS REQUIRED SO THAT A NAIL FOR THAT PIECE WILL NOT BE DRIVEN THROUGH ONTO OR RIGHT BESIDE A NAIL IN A LOWER PIECE.
- H. PORTIONS OF ONE OF THE FLATRACK ENDWALLS DEPICTED WITHIN THIS DRAWING HAVE NOT BEEN SHOWN IN THE LOAD VIEW FOR CLARITY PURPOSES.
- J. WHEN INSTALLING END BLOCKING ASSEMBLIES, THE ASSEMBLIES MUST BE POSITIONED SO AS TO BE SUPPORTED AND IN LINE WITH THE STRONG POINTS OF THE FLATRACK ENDWALLS. NOTE: SOME FLATRACK ENDWALLS WILL REQUIRE FILL PIECES TO BE INSTALLED ON THE END BLOCKING ASSEMBLY OR NOTCHES TO BE CUT IN THE LOWER BEAM ASSEMBLY TO PROVIDE A UNIFORM LOAD BEARING SURFACE. NAIL ANY FILL PIECES TO THE END BLOCKING ASSEMBLY W/1 APPROPRIATELY SIZED NAIL EVERY 6".
- K. WHEN STEEL STRAPPING IS SEALED IN AN END-OVER-END LAP JOINT, A MINIMUM OF ONE SEAL WITH TWO PAIR OF NOTCHES WILL BE USED TO SEAL THE JOINT WHEN A NOTCH-TYPE SEALER IS BEING USED. A MINIMUM OF TWO SEALS, BUTTED TOGETHER WITH TWO PAIR OF CRIMPS PER SEAL, WILL BE USED TO SEAL THE JOINT WHEN A CRIMP-TYPE SEALER IS BEING USED. REFER TO THE "STRAP JOINT A" AND "STRAP JOINT B" DETAILS ON PAGE 8 FOR GUIDANCE.
- L. MAXIMUM LOAD WEIGHT CRITERIA:
THE MAXIMUM LOAD WEIGHTS ARE CONTROLLED BY EQUIPMENT CAPABILITY FACTORS. ALTHOUGH THE HEAVIEST MAXIMUM LOADS ARE DELINEATED IN THE LOAD VIEWS, PROVISIONS ARE INCLUDED WITHIN THIS DRAWING SO THAT THE BASIC LOADS CAN BE ADJUSTED TO SATISFY A LESSER QUANTITY OF LADING UNITS. DEPENDING ON TRANSPORTATION ROUTING, IT MAY BE NECESSARY TO REDUCE THE LOAD WEIGHT TO SATISFY "WEIGHT LAWS" OF CERTAIN STATES. ALSO, IT MAY BE NECESSARY TO REDUCE THE LOAD WEIGHT TO SATISFY OTHER WEIGHT RESTRICTIONS IMPOSED ON THE INTERMODAL CONTAINER SYSTEM.
- M. REQUIREMENTS CITED WITHIN THE BUREAU OF EXPLOSIVES PAMPHLET 6C APPLY WHEN THE SHIPMENT MOVES BY TRAILER/CONTAINER-ON-FLATCAR (T/COFC). SPECIAL T/COFC NOTES FOLLOW:
1. A LOADED CONTAINER MUST BE ON A CHASSIS EQUIPPED WITH TWO BOGIE ASSEMBLIES WHEN BEING MOVED IN TOFC SERVICE.
 2. THE LOAD LIMIT OF A T/COFC RAILCAR MUST NOT BE EXCEEDED, NOR WILL A CAR BE LOADED SO THAT THE TRUCK UNDER ONE END OF THE CAR CARRIES MORE THAN ONE-HALF OF THE LOAD LIMIT FOR THAT CAR.
- N. DURING INTRASTATE AND/OR INTERSTATE MOVES BY MOTOR CARRIER, A PROPER CHASSIS OR MODIFIED FLAT BED TRAILER MUST BE USED TO PRECLUDE VIOLATION OF ONE OR MORE "WEIGHT LAWS" APPLICABLE TO THE STATE OR STATES INVOLVED.
- O. THE 2" STRAPPING USED FOR LOAD SECUREMENT, I.E., HOLD-DOWN STRAPS, WILL ONLY BE FASTENED TO THE FLATRACK CONTAINER BY UTILIZING TIEDOWN PROVISIONS LOCATED ON THE TOP OR ALONG THE SIDE OF THE FLATRACK BOTTOM SIDE RAILS. CAUTION: THE LOAD SECUREMENT STRAPS WILL NOT BE POSITIONED AROUND THE UNDERSIDE OR THROUGH THE FORKLIFT POCKETS OF THE FLATRACK CONTAINER. ADDITIONALLY, THE FLATRACK TIEDOWN PROVISIONS MUST BE AT LEAST AS STRONG AS THE 2" LOAD SECUREMENT STRAPPING BEING USED; AND BE OF A SUFFICIENT WIDTH TO RECEIVE THE 2" STRAPPING AND BE OF A DESIGN WHICH WILL PROVIDE A BEARING SURFACE ACROSS THE FULL WIDTH OF THE 2" STRAPPING SO THAT THE STRAPPING WILL NOT BE DEFORMED, ESPECIALLY AT ITS EDGES, WHEN PROPERLY TENSIONED.
- P. THE OUTLOADING PROCEDURES SPECIFIED HEREIN CAN ALSO BE UTILIZED FOR THE SHIPMENT OF THE DEPICTED CONTAINERS WHEN THEY ARE LOADED WITH AN ITEM WHICH IS IDENTIFIED DIFFERENTLY BY NOMENCLATURE THAN THE ITEM DESIGNATED IN THE DRAWING TITLE.
- Q. REFER TO ASSOCIATION OF AMERICAN RAILROADS MANUAL "GENERAL RULES GOVERNING THE LOADING OF COMMODITIES ON OPEN TOP CARS" FOR APPLICABLE LOADING RULES AS FOLLOWS: PREFACE, 1A, 2, 5, 10, AND 15. NOTE THAT ALL STRAPPING USED FOR LOAD SECUREMENT, I.E., HOLD-DOWN STRAPS, MUST BE MARKED AS SPECIFIED IN LOADING RULE 15.
- R. ANTI-CHAFING MATERIAL MAY BE INSTALLED AT POINTS OF CONTACT BETWEEN CONTAINERS AND STEEL STRAPPING, IF DESIRED, TO PREVENT CHAFING DAMAGE TO CONTAINER PAINT AND MARKINGS.
- S. CONVERSION TO METRIC EQUIVALENTS: DIMENSIONS WITHIN THIS DOCUMENT ARE EXPRESSED IN INCHES AND WEIGHTS ARE EXPRESSED IN POUNDS. WHEN NECESSARY, THE METRIC EQUIVALENTS MAY BE COMPUTED ON THE BASIS OF ONE INCH EQUALS 25.4 MM AND ONE POUND EQUALS 0.454 KG.
- T. THE LOAD AS SHOWN ON PAGE 4 MAY BE REDUCED BY ONE OR TWO LAYERS FOR A SHIPMENT OF EIGHT OR FOUR CONTAINERS, IF DESIRED.
- U. WHETHER A FLATRACK IS FULL OR IS LOADED WITH A REDUCED QUANTITY OF LADING UNITS, THE LENGTHWISE CENTER OF GRAVITY OF THE LOAD MUST BE WITHIN 12", IN EITHER DIRECTION, OF THE MID-POINT OF THE FLATRACK.

(CONTINUED AT RIGHT)

MATERIAL SPECIFICATIONS

LUMBER	---	SEE TM 743-200-1 (DUNNAGE LUMBER) AND FED SPEC MM-L-751.
NAILS	---	FED SPEC FF-N-105; COMMON.
STRAPPING, STEEL	--	ASTM D3953; FLAT STRAPPING, TYPE 1, HEAVY DUTY, FINISH A, B (GRADE 2), OR C.
SEAL, STRAP	---	ASTM D3953; CLASS H, FINISH A, B (GRADE 2), OR C, DOUBLE NOTCH TYPE, STYLE I, II, OR IV.
STAPLE, STRAP	---	COMMERCIAL GRADE.
ANTI-CHAFING MATERIAL	---	MIL-B-121 (OR EQUAL); NEUTRAL BARRIER MATERIAL.

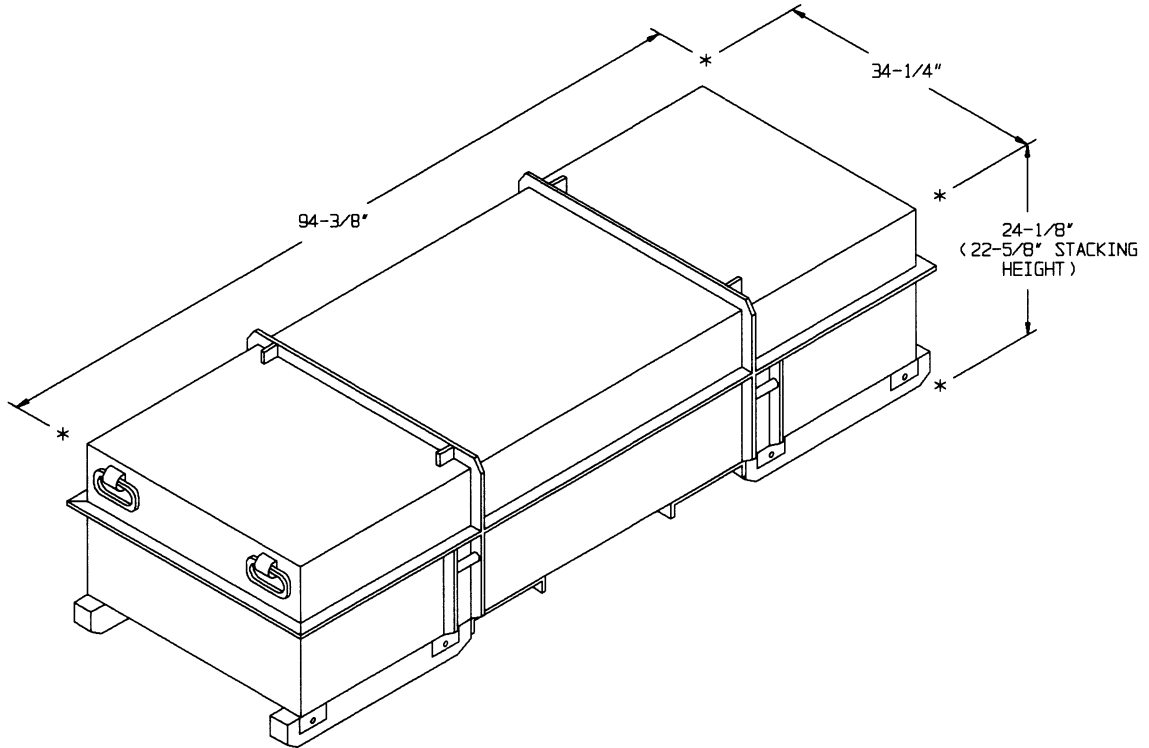

CNU-80/E OR CNU-203/E CONTAINER

CNU-80/E WEIGHT - - - - - 934 TO 1,174 LBS (APPROX)
 CNU-203/E WEIGHT - - - - - 850 LBS (APPROX)
 CUBE - - - - - 45.2 CUBIC FEET (APPROX)

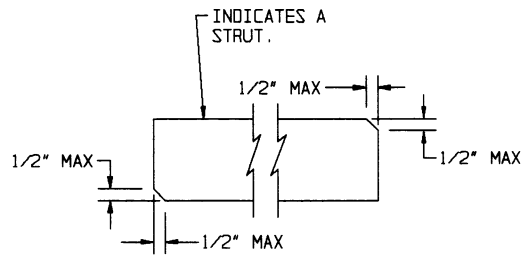

BEVEL-CUT

IF DESIRED, EACH END OF A STRUT MAY BE BEVEL-CUT AS SHOWN ABOVE TO FACILITATE THE ACHIEVEMENT OF A TIGHT CENTER OF LOAD FIT.

INDICATES CNU-203/E CONTAINER.
SEE SPECIAL NOTE 3 ON PAGE 5.

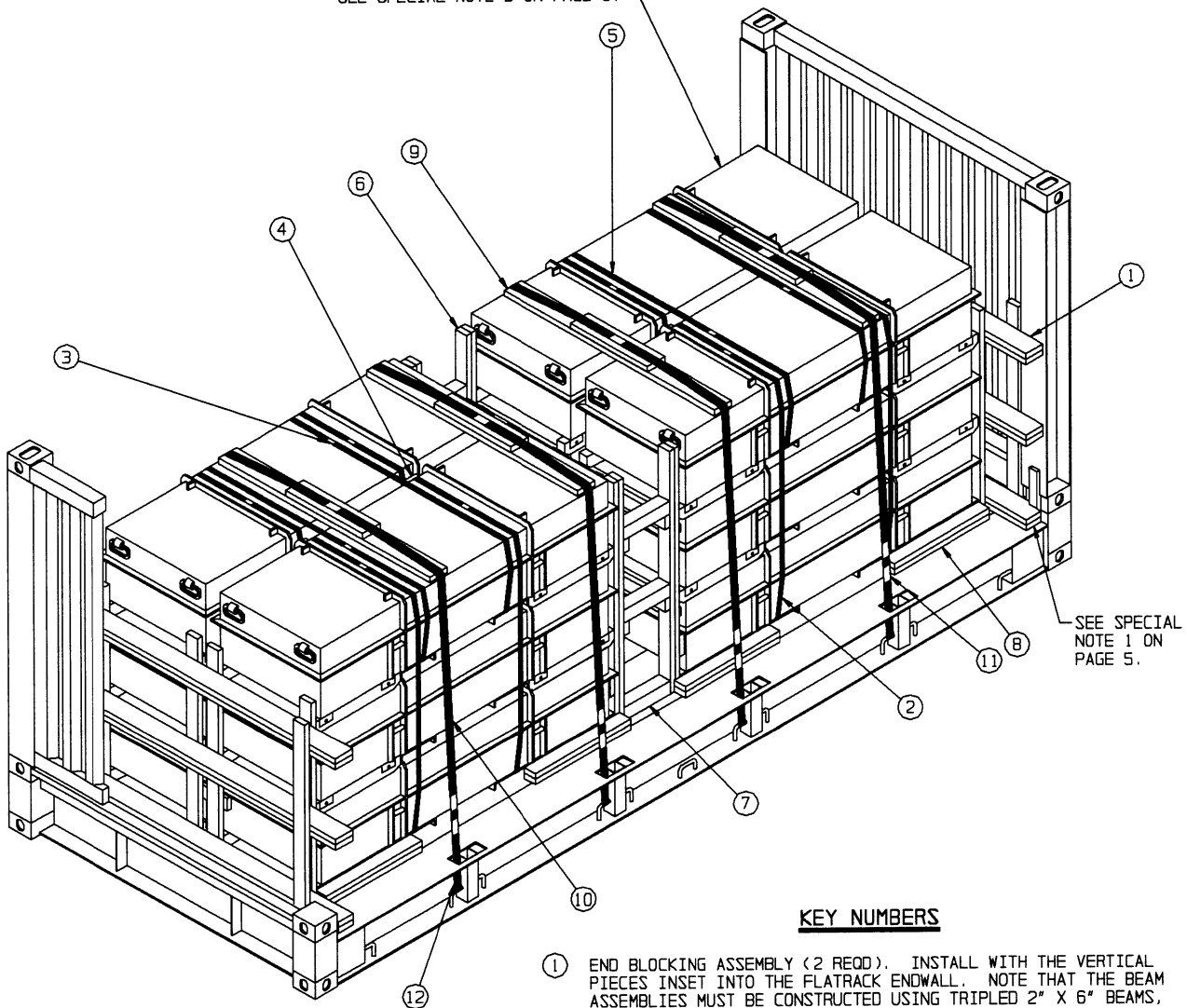

ISOMETRIC VIEW

(KEY NUMBERS CONTINUED)

- ⑩ HOLD-DOWN STRAP, 2" X .044" OR .050" BY A LENGTH TO SUIT (REF: 23'-0") (4 REQD). INSTALL EACH STRAP FROM TWO 11'-6" LONG PIECES. STAPLE TO THE STRAPPING BOARD W/2 STAPLES EACH.
- ⑪ SEAL FOR 2" STRAPPING (20 REQD). FASTEN PIECE MARKED ⑩ WITH ONE SEAL CRIMPED WITH TWO PAIR OF NOTCHES. FASTEN PIECE MARKED ⑫ WITH ONE SEAL CRIMPED WITH ONE PAIR OF NOTCHES. SEE THE "TIEDOWN DETAIL" ON PAGE 8.
- ⑫ PAD, STRAPPING, 2" X .044" OR .050" X 18" (8 REQD). PRE-POSITION THE PAD BETWEEN THE HOLD-DOWN STRAP, PIECE MARKED ⑩, AND THE FLATRACK TIEDOWN PROVISIONS. FASTEN WITH ONE SEAL CRIMPED WITH ONE PAIR OF NOTCHES. SEE THE "TIEDOWN DETAIL" ON PAGE 8.

KEY NUMBERS

- ① END BLOCKING ASSEMBLY (2 REQD). INSTALL WITH THE VERTICAL PIECES INSET INTO THE FLATRACK ENDWALL. NOTE THAT THE BEAM ASSEMBLIES MUST BE CONSTRUCTED USING TRIPLED 2" X 6" BEAMS, INSTEAD OF DOUBLED 2" X 6" BEAMS WHEN THE COMBINED WEIGHT OF THE CONTAINERS EXCEEDS 13,000 POUNDS. SEE THE DETAIL ON PAGE 6 AND SPECIAL NOTE 1 ON PAGE 5.
- ② UNITIZING STRAP, 1-1/4" X .035" OR .031" BY A LENGTH TO SUIT (REF: 17'-3") (8 REQD). INSTALL TO UNITIZE ONE STACK OF THREE CONTAINERS.
- ③ SEAL FOR 1-1/4" STRAPPING (12 REQD, 1 PER STRAP). CRIMP EACH SEAL WITH TWO PAIR OF NOTCHES.
- ④ ANTI-CHAFING ASSEMBLY (2 REQD). INSTALL TO FIT BETWEEN THE MIDDLE RIBS OF A CONTAINER STACK. SEE THE DETAIL ON PAGE 7.
- ⑤ BUNDLING STRAP, 1-1/4" X .035" OR .031" BY A LENGTH TO SUIT (REF: 15'-6") (4 REQD). INSTALL TO ENCIRCLE THE UPPER LAYER OF CONTAINERS.
- ⑥ CENTER GATE (2 REQD). SEE THE DETAIL ON PAGE 7.
- ⑦ STRUT, 4" X 4" BY CUT-TO-FIT (REF: 14'-1/4") (6 REQD). TOENAIL TO THE CENTER GATE W/2-12d NAILS AT EACH END. SEE THE "BEVEL-CUT" DETAIL ON PAGE 3.
- ⑧ SIDE BLOCKING, 2" X 4" X 30" (DOUBLED) (8 REQD). INSTALL THE FIRST PIECE AGAINST A CONTAINER SKID, AS SHOWN ABOVE, AND NAIL TO THE FLATRACK FLOOR W/4-10d NAILS. LAMINATE THE SECOND PIECE TO THE FIRST PIECE W/4-10d NAILS. NOTE: THE CENTER FOUR SIDE BLOCKING PIECES MUST ALSO EXTEND BEYOND THE CENTER GATES TO PREVENT LATERAL MOVEMENT OF THE CENTER GATES.
- ⑨ STRAPPING BOARD ASSEMBLY (4 REQD). SEE THE DETAIL ON PAGE 6 AND SPECIAL NOTE 2 ON PAGE 5.

(CONTINUED AT LEFT)

SPECIAL NOTES:

1. THE BOTTOM BEAM ASSEMBLY IN THE END BLOCKING ASSEMBLY MUST BE NOTCHED IN ORDER TO AVOID CONTACT WITH THE FLATRACK HINGE. THE BEAM ASSEMBLIES, HOWEVER, MUST STILL BEAR AGAINST THE FLATRACK STRONG POINTS.
2. POSITION THE STRAPPING BOARD ASSEMBLIES AND THE HOLD-DOWN STRAPS SO AS TO BE VERTICALLY IN LINE WITH THE FLATRACK TIEDOWN POINTS.
3. CNU-203/E CONTAINERS WEIGHING 850 POUNDS HAVE BEEN SHOWN IN THE LOAD ON PAGE 4 AS TYPICAL ONLY. CNU-80/E CONTAINERS AND CNU-203/E CONTAINERS OF OTHER WEIGHTS MAY ALSO BE LOADED AS DEPICTED ON PAGE 4. SEE KEY NUMBER 1 ON PAGE 4 WHEN LOADING CONTAINERS WEIGHING MORE THAN 1,083 POUNDS.
4. THE LOAD AS SHOWN MAY BE REDUCED BY ONE OR TWO LAYERS, IF DESIRED, FOR A SHIPMENT OF EIGHT OR FOUR CONTAINERS.

BILL OF MATERIAL		
LUMBER	LINEAR FEET	BOARD FEET
1" X 4"	19	7
2" X 4"	188	126
2" X 6"	124	124
4" X 4"	8	11
NAILS	NO. REQD	POUNDS
6d (2")	24	1/4
10d (3")	318	5
12d (3-1/4")	24	1/2
STEEL STRAPPING, 1-1/4" -- 200' REQD	----	29 LBS
SEAL FOR 1-1/4" STRAPPING -- 12 REQD	----	3/4 LBS
STEEL STRAPPING, 2" ----- 104' REQD	----	35 LBS
SEAL FOR 2" STRAPPING ----- 20 REQD	----	4 LBS
STAPLE ----- 8 REQD	----	NIL

LOAD AS SHOWN

<u>ITEM</u>	<u>QUANTITY</u>	<u>WEIGHT (APPROX)</u>
CNU-203/E	12	10,200 LBS
DUNNAGE		611 LBS
CONTAINER		5,700 LBS
TOTAL WEIGHT		16,511 LBS (APPROX)

VERTICAL PIECE, 2" X 4" X 55" (6 REQD). NAIL TO THE BEAM ASSEMBLIES W/3-10d NAILS AT EACH JOINT.

BEAM ASSEMBLY, 2" X 6" X 7'-10" (DOUBLED) (3 REQD). LAMINATE THE FIRST PIECE TO THE SECOND W/11-10d NAILS. NOTE: THE BEAM ASSEMBLY MUST BE CONSTRUCTED OF TRIPLED INSTEAD OF DOUBLED 2" X 6" MATERIAL WHEN THE TOTAL WEIGHT OF THE CONTAINERS TO BE LOADED EXCEEDS 13,000 POUNDS. LAMINATE THE THIRD PIECE TO THE SECOND W/11-10d NAILS, AND REPOSITION THE BOTTOM BEAM ASSEMBLY AT 4-1/2".

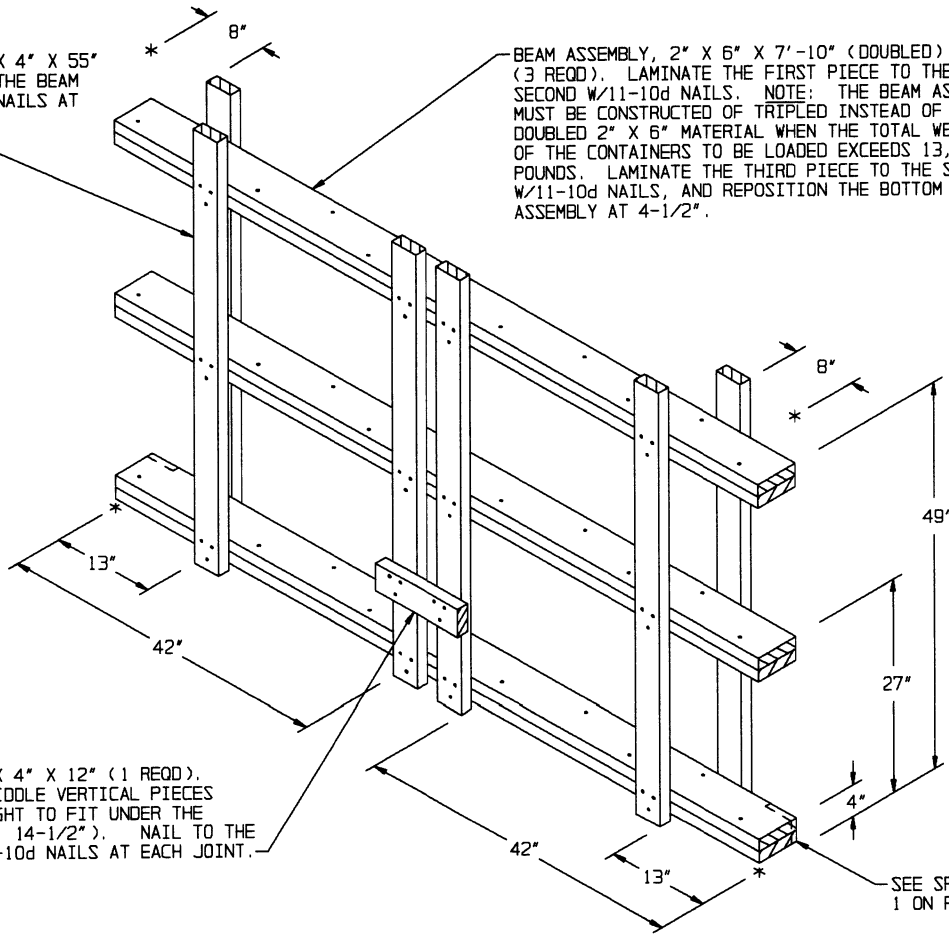

RETAINER PIECE, 2" X 4" X 12" (1 REQD). CENTER ON THE TWO MIDDLE VERTICAL PIECES AND LOCATE AT A HEIGHT TO FIT UNDER THE CONTAINER RIB (REF: 14-1/2"). NAIL TO THE VERTICAL PIECES W/3-10d NAILS AT EACH JOINT.

SEE SPECIAL NOTE 1 ON PAGE 5.

END BLOCKING ASSEMBLY

NOTE: FOR A TWO HIGH LOAD, ELIMINATE THE TOP BEAM ASSEMBLY, AND FOR A ONE HIGH LOAD, ELIMINATE THE TOP TWO BEAM ASSEMBLIES. SHORTEN THE VERTICAL PIECES APPROPRIATELY.

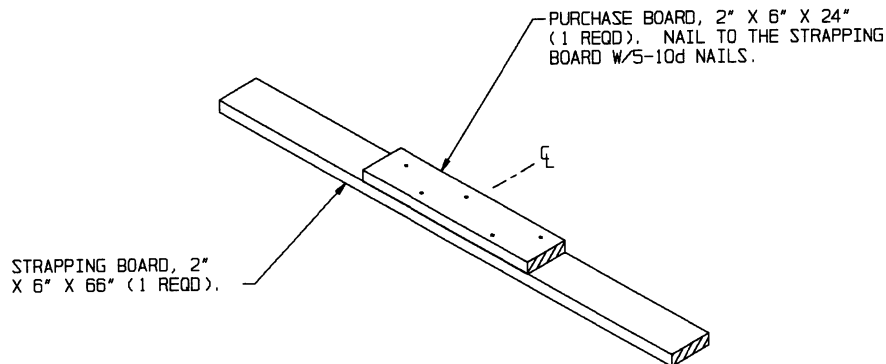

STRAPPING BOARD, 2" X 6" X 66" (1 REQD).

PURCHASE BOARD, 2" X 6" X 24" (1 REQD). NAIL TO THE STRAPPING BOARD W/5-10d NAILS.

STRAPPING BOARD ASSEMBLY

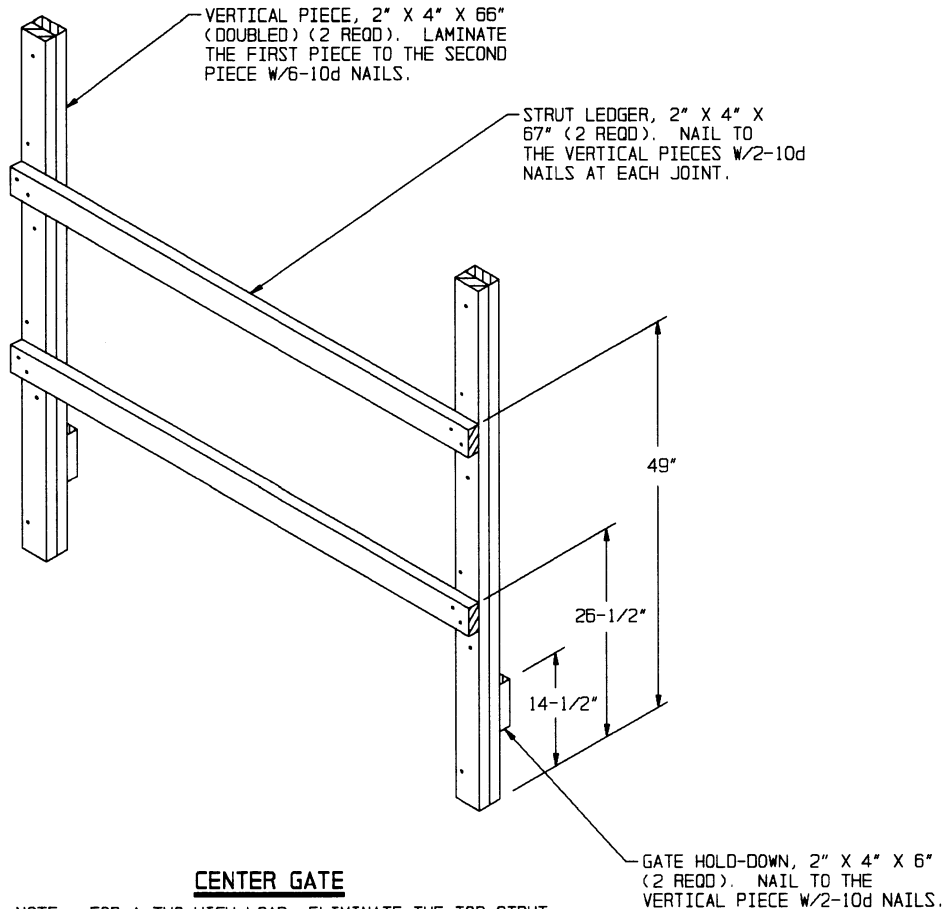

CENTER GATE

NOTE: FOR A TWO HIGH LOAD, ELIMINATE THE TOP STRUT LEDGER AND SHORTEN THE VERTICAL PIECES TO 44". FOR A ONE HIGH LOAD, ELIMINATE THE TOP STRUT LEDGER AND SHORTEN THE VERTICAL PIECES TO 26-1/2".

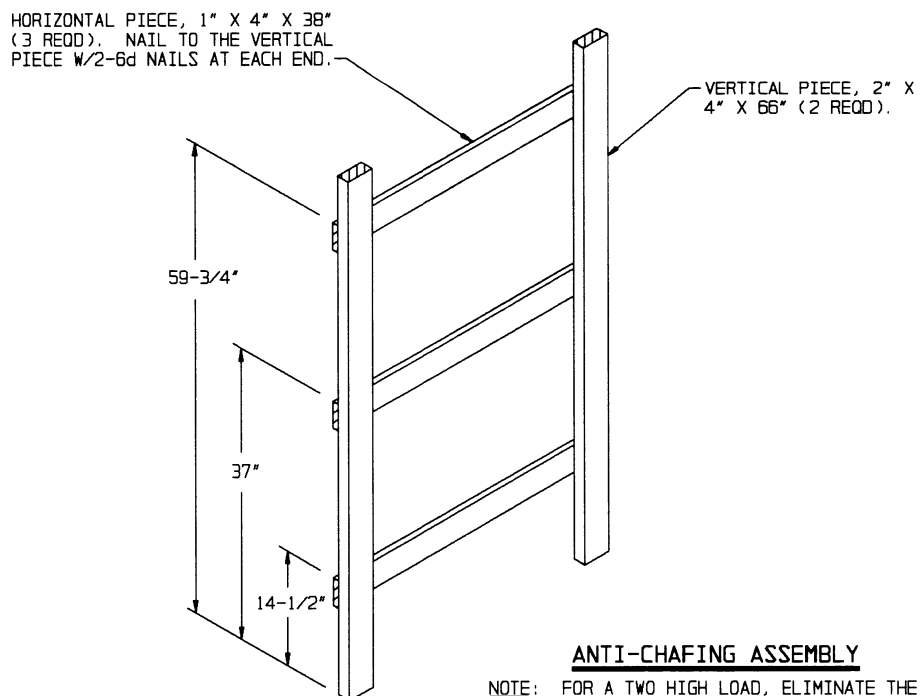

ANTI-CHAFING ASSEMBLY

NOTE: FOR A TWO HIGH LOAD, ELIMINATE THE TOP HORIZONTAL PIECE, AND FOR A ONE HIGH LOAD, ELIMINATE THE TOP TWO HORIZONTAL PIECES. SHORTEN THE VERTICAL PIECES APPROPRIATELY.

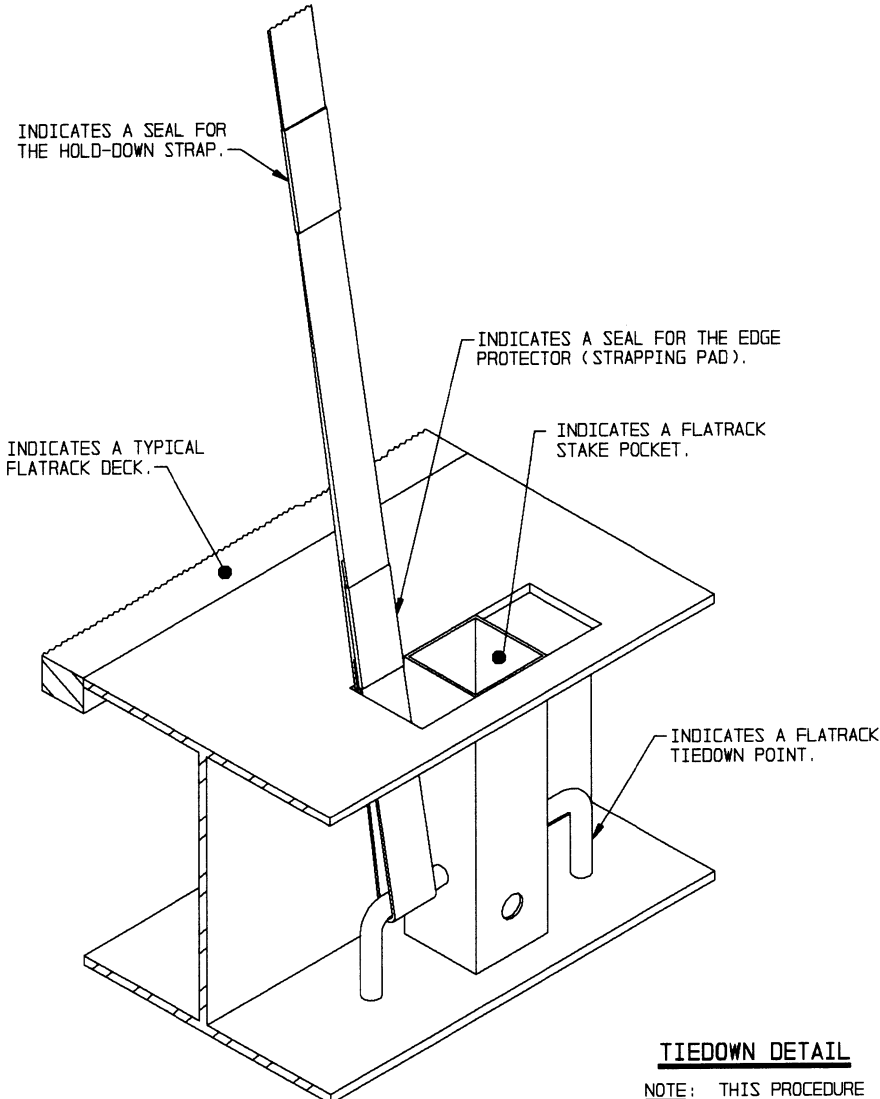

PARTIAL ISOMETRIC SECTION VIEW

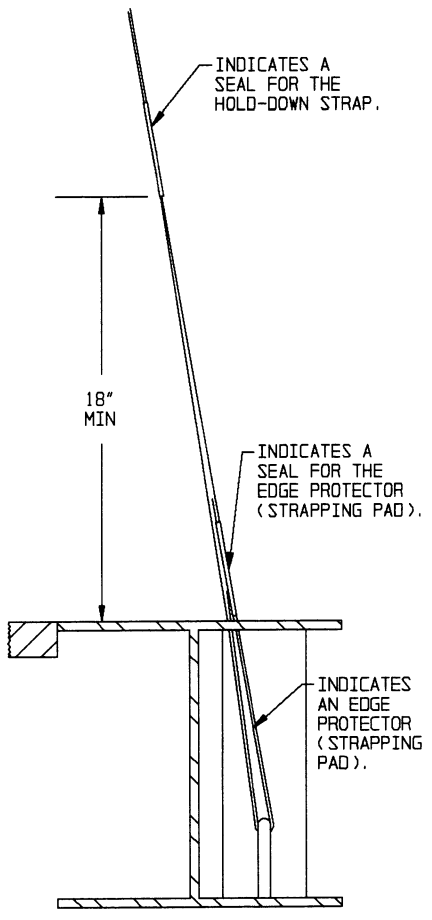

PARTIAL SIDE VIEW

TIEDOWN DETAIL

NOTE: THIS PROCEDURE IS USED FOR TIEDOWN OF THE LOAD USING FLATRACK SIDE RAIL TIEDOWN POINTS. SEE GENERAL NOTE "0" ON PAGE 2.

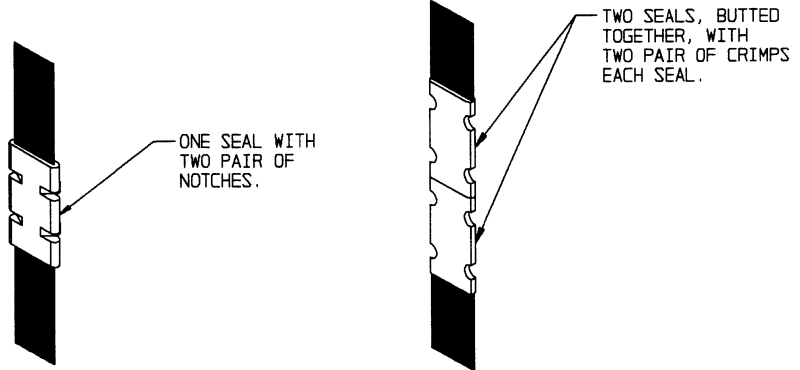

STRAP JOINT A

METHOD OF SECURING A STRAP JOINT WHEN USING A NOTCH-TYPE SEALER.

STRAP JOINT B

METHOD OF SECURING A STRAP JOINT WHEN USING A CRIMP-TYPE SEALER.

STRAP/SEAL DETAIL

DETAILS