

APPROVED BY  
BUREAU OF EXPLOSIVES

*J. A. Hershman*  
DATE *10/27/92*

# LOADING AND BRACING IN SIDE OPENING ISO CONTAINERS OF MAVERICK (AGM-65) MISSILES IN CNU-399/E AND CNU-425/E SHIPPING AND STORAGE CONTAINERS

INDEX

<u>ITEM</u>	<u>PAGE(S)</u>
TYPICAL LOADING PROCEDURES - - - - -	2
GENERAL NOTES AND MATERIAL SPECIFICATIONS - - - - -	3
CONTAINER DETAIL - - - - -	4
DETAILS - - - - -	5-6
LESS-THAN-FULL-LOAD DETAILS - - - - -	7

- LOADING AND BRACING SPECIFICATIONS SET FORTH WITHIN THIS DRAWING ARE APPLICABLE TO LOADS THAT ARE TO BE SHIPPED BY TRAILER/CONTAINER-ON-FLAT CAR (T/COFC) RAIL CARRIER SERVICE. THESE SPECIFICATIONS MAY ALSO BE USED FOR LOADS THAT ARE TO BE MOVED BY MOTOR OR WATER CARRIERS. SEE GENERAL NOTE "J" ON PAGE 3.

U. S. ARMY MATERIEL COMMAND DRAWING			
APPROVED, U.S. ARMY ARMAMENT, MUNITIONS AND CHEMICAL COMMAND  <i>Timothy R. Foe</i>	DRAFTSMAN	TECHNICIAN	ENGINEER
			L. FIEFFER
APPROVED BY ORDER OF COMMANDING GENERAL, U.S. ARMY MATERIEL COMMAND  <i>William F Ernst</i>	VALIDATION ENGINEERING DIVISION	TRANSPORTATION ENGINEERING DIVISION	LOGISTICS ENGINEERING OFFICE
	<i>AM JNK</i>	<i>W. Fierich</i>	<i>W F Ernst</i>
JANUARY 1993			
	CLASS	DIVISION	DRAWING
	19	48	8502
			FILE
			SP15K4

DO NOT SCALE

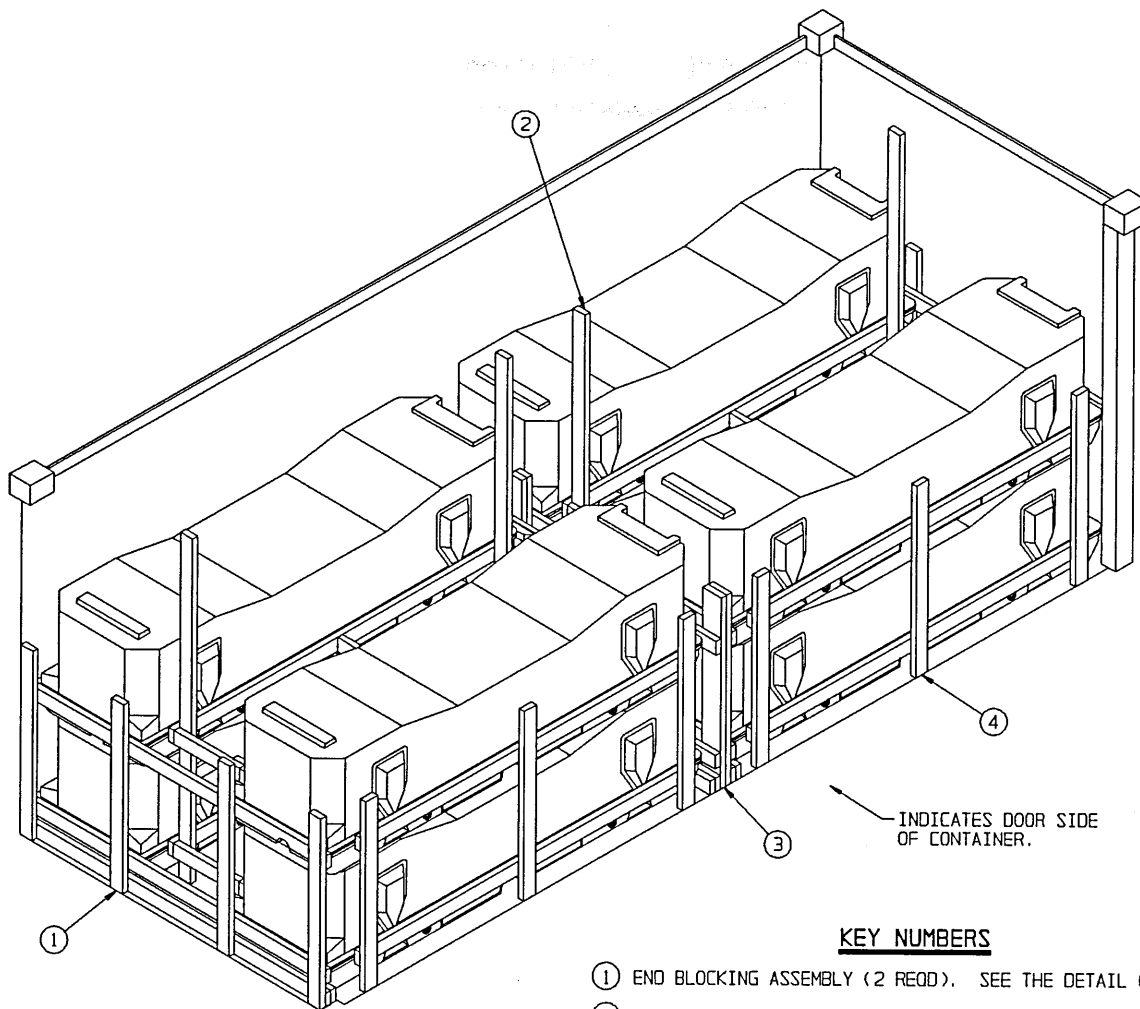

ISOMETRIC VIEW

INDICATES DOOR SIDE OF CONTAINER.

KEY NUMBERS

- ① END BLOCKING ASSEMBLY (2 REOD). SEE THE DETAIL ON PAGE 5.
- ② FILLER ASSEMBLY (2 REOD). SEE THE DETAIL ON PAGE 6.
- ③ CENTER FILL ASSEMBLY (1 REOD). SEE THE DETAIL ON PAGE 5.
- ④ SIDE FILL ASSEMBLY (2 REOD). SEE THE DETAIL ON PAGE 6.

BILL OF MATERIAL

LUMBER	LINEAR FEET	BOARD FEET
2" X 4"	355	237
2" X 6"	8	8
NAILS	NO. REOD	POUNDS
10d (3")	260	4

LOAD AS SHOWN

ITEM	QUANTITY	WEIGHT (APPROX)
CNU-399 OR 425	8	8,120 LBS
DUNNAGE		494 LBS
CONTAINER		6,050 LBS

TOTAL WEIGHT ----- 14,664 LBS (APPROX)

(GENERAL NOTES CONTINUED)

GENERAL NOTES

- M. THE QUANTITY OF CONTAINERS SHOWN IN THE LOAD ON PAGE 2 MAY BE REDUCED FOR SHIPMENT, IF DESIRED. SEE THE DETAILS ON PAGE 7. WHEN A CONTAINER IS TO BE LOADED WITH A REDUCED QUANTITY OF LADING UNITS, THE LENGTHWISE CENTER OF GRAVITY OF THE LOAD MUST BE WITHIN 12", IN EITHER DIRECTION, OF THE MID-POINT OF THE CONTAINER.
  - 1. IF A LOAD IS REDUCED BY ONLY A SMALL AMOUNT (ONE, TWO OR THREE LADING UNITS), LADING UNITS NORMALLY MAY BE ELIMINATED FROM THE EITHER END OF THE LOAD, AS LONG AS THE CONDITIONS STATED IMMEDIATELY ABOVE ARE ADHERED TO.
  - 2. IF A LOAD IS REDUCED BY A LARGE AMOUNT (MORE THAN THREE LADING UNITS), LADING UNITS SHOULD BE ELIMINATED AS REQUIRED AND THE TOTAL LOAD SHIFTED FORE OR AFT, AS NECESSARY, TO ACHIEVE A SYMMETRICAL WEIGHT DISTRIBUTION. THE DEPICTED PROCEDURES WILL BE FOLLOWED AS CLOSELY AS POSSIBLE, MAKING ONLY THOSE ADJUSTMENTS TO THE DUNNAGE WHICH ARE REQUIRED TO ACCOMMODATE THE NUMBER OF UNITS TO BE SHIPPED.
- N. RECOMMENDED SEQUENTIAL LOADING PROCEDURES:
  - 1. PREFABRICATE TWO END BLOCKING ASSEMBLIES, TWO SIDE FILL ASSEMBLIES, TWO FILLER ASSEMBLIES AND ONE CENTER FILL ASSEMBLY.
  - 2. INSTALL ONE END BLOCKING ASSEMBLY.
  - 3. LOAD TWO CONTAINERS.
  - 4. REPEAT STEP 2.
  - 5. REPEAT STEP 3.
  - 6. INSTALL TWO FILLER ASSEMBLIES.
  - 7. LOAD FOUR CONTAINERS.
  - 8. INSTALL ONE CENTER FILL ASSEMBLY.
  - 9. INSTALL TWO SIDE FILL ASSEMBLIES.

- A. THIS DOCUMENT HAS BEEN PREPARED AND ISSUED IN ACCORDANCE WITH AR 740-1 AND AUGMENTS TM 743-200-1 (CHAPTER 5).
- B. THE SPECIFIED OUTLOADING PROCEDURES ARE APPLICABLE TO LOADS OF MAVERICK (AGM-65) MISSILES PACKED IN CNU-399/E OR CNU-425/E CONTAINERS. SUBSEQUENT REFERENCE TO CONTAINER HEREIN MEANS THE CNU-399/E OR CNU-425/E CONTAINER WITH MISSILES INSTALLED. SEE PAGE 4 FOR DETAILS OF THE CONTAINER. CAUTION: REGARDLESS OF THE QUANTITY OF CONTAINERS TO BE SHIPPED, THE "MAXIMUM GROSS WEIGHT" OF THE SIDE OPENING ISO CONTAINER MUST NOT BE EXCEEDED.
- C. THE LOAD AS SHOWN IS BASED ON A 6,050 POUND 20' LONG BY 8' WIDE BY 8'-6" HIGH SIDE OPENING INTERMODAL COMMERCIAL CONTAINER WITH INSIDE DIMENSIONS OF 19'-4" LONG BY 89" WIDE BY 88" HIGH. THE LOAD IS DESIGNED FOR TRAILER/CONTAINER-ON-FLAT-CAR (T/COFC) SHIPMENT, HOWEVER, THE LOAD AS DESIGNED CAN ALSO BE MOVED BY OTHER SURFACE MODES OF TRANSPORT. NOTICE: OTHER CONTAINERS OF THE SAME DESIGN CONFIGURATION CAN BE USED.
- D. WHEN LOADING CONTAINERS, THEY ARE TO BE POSITIONED SO AS TO ACHIEVE A TIGHT LOAD (TIGHT AGAINST THE DUNNAGE ASSEMBLIES). ALTHOUGH A TOTAL OF 1 1/2" OF UNBLOCKED SPACE ACROSS THE WIDTH OF A LOAD BAY IS PERMITTED, LATERAL VOIDS WITHIN THE LOAD ARE TO BE HELD TO A MINIMUM. EXCESSIVE SLACK CAN BE ELIMINATED FROM A LOAD BY LAMINATING ADDITIONAL PIECES OF APPROPRIATE THICKNESS TO THE HORIZONTAL PIECES ON THE CENTER FILL ASSEMBLY. NAIL EACH ADDITIONAL PIECE W/1 APPROPRIATELY SIZED NAIL EVERY 12". ADDITIONALLY, THE THICKNESS AND/OR QUANTITY OF THE VERTICAL AND HORIZONTAL PIECES IN THE CENTER FILL ASSEMBLY MAY BE ADJUSTED AS REQUIRED TO FACILITATE VARIANCE IN THE CONTAINER SIZE.
- E. DUNNAGE LUMBER SPECIFIED IS OF NOMINAL SIZE. FOR EXAMPLE, 1" X 4" MATERIAL IS ACTUALLY 3/4" THICK BY 3-1/2" WIDE AND 2" X 6" MATERIAL IS ACTUALLY 1-1/2" BY 5-1/2" WIDE.
- F. A STAGGERED NAILING PATTERN WILL BE USED WHENEVER POSSIBLE WHEN NAILS ARE DRIVEN INTO JOINTS OF DUNNAGE ASSEMBLIES OR WHEN LAMINATING DUNNAGE. ADDITIONALLY, THE NAILING PATTERN FOR AN UPPER PIECE OF LAMINATED DUNNAGE WILL BE ADJUSTED AS REQUIRED SO THAT A NAIL FOR THAT PIECE WILL NOT BE DRIVEN THROUGH ONTO OR RIGHT BESIDE A NAIL IN A LOWER PIECE.
- G. CAUTION: DO NOT NAIL DUNNAGE MATERIAL TO THE CONTAINER WALLS OR FLOOR. ALL NAILING WILL BE WITHIN THE DUNNAGE.
- H. PORTIONS OF THE CONTAINER DEPICTED WITHIN THIS DRAWING, SUCH AS THE SIDE DOORS, HAVE NOT BEEN SHOWN IN THE LOAD VIEWS FOR CLARITY PURPOSES.
- J. REQUIREMENTS CITED WITHIN THE BUREAU OF EXPLOSIVES PAMPHLET 6C APPLY WHEN THE SHIPMENT MOVES BY TRAILER/CONTAINER-ON-FLAT-CAR (T/COFC). SPECIAL T/COFC NOTES FOLLOW:
  - 1. A LOADED CONTAINER MUST BE ON A CHASSIS EQUIPPED WITH TWO BOGIE ASSEMBLIES WHEN BEING MOVED IN TOFC SERVICE.
  - 2. THE LOAD LIMIT OF A T/COFC RAILCAR MUST NOT BE EXCEEDED, NOR WILL A CAR BE LOADED SO THAT THE TRUCK UNDER ONE END OF THE CAR CARRIES MORE THAN ONE-HALF OF THE LOAD LIMIT FOR THAT CAR.
- K. DURING INTRASTATE AND/OR INTERSTATE MOVES BY MOTOR CARRIER, A PROPER CHASSIS OR MODIFIED FLAT BED TRAILER MUST BE USED TO PRECLUDE VIOLATION OF ONE OR MORE "WEIGHT LAWS" APPLICABLE TO THE STATE OR STATES INVOLVED.
- L. CONVERSION TO METRIC EQUIVALENTS: DIMENSIONS WITHIN THIS DOCUMENT ARE EXPRESSED IN INCHES AND WEIGHTS ARE EXPRESSED IN POUNDS. WHEN NECESSARY, THE METRIC EQUIVALENTS MAY BE COMPUTED ON THE BASIS OF ONE INCH EQUALS 25.4MM AND ONE POUND EQUALS 0.454KG.

MATERIAL SPECIFICATIONS

LUMBER - - - - - : SEE TM 743 200 1 (DUNNAGE LUMBER) AND FED SPEC MM-L-751.

NAILS - - - - - : FED SPEC FF-N-105; COMMON.

(CONTINUED AT LEFT)

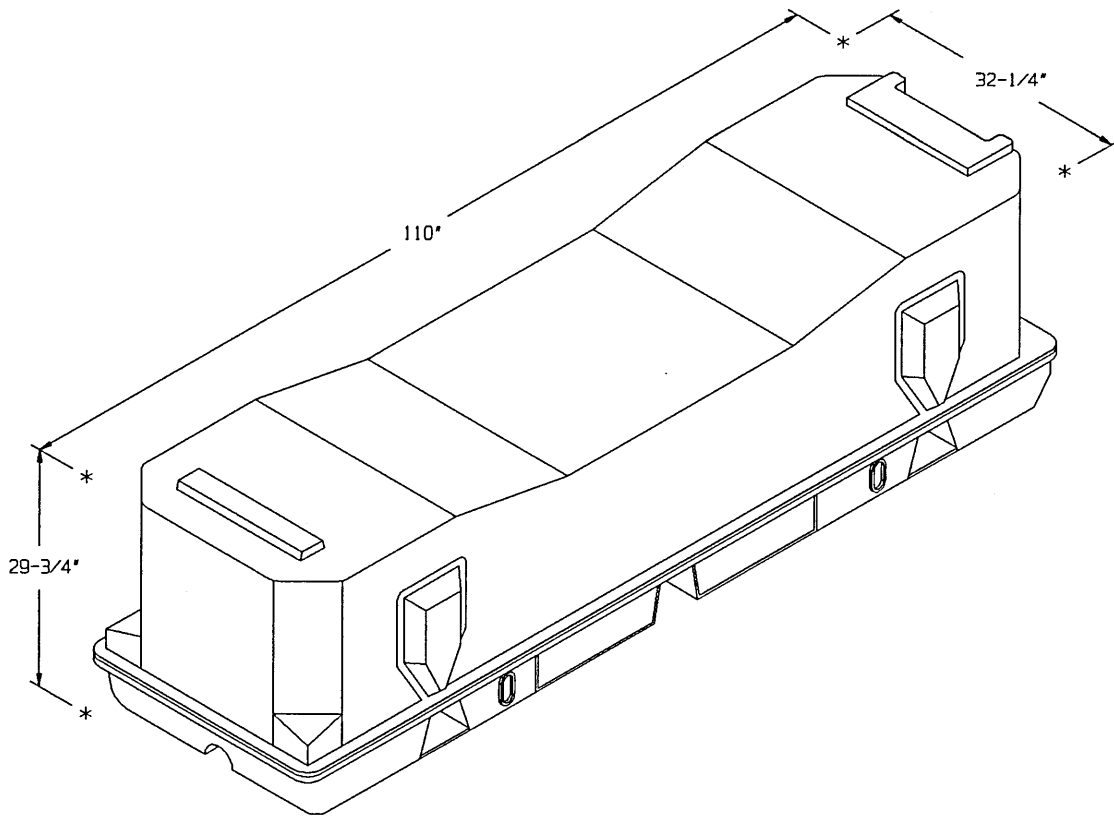

CNU-399/E OR CNU-425/E CONTAINER

CONTAINER WEIGHT (MAX) - - - 1,015 LBS (APPROX)  
CUBE - - - - - 61.1 CU FT (APPROX)

VERTICAL PIECE, 2" X 4" X 48" (4 REOD).

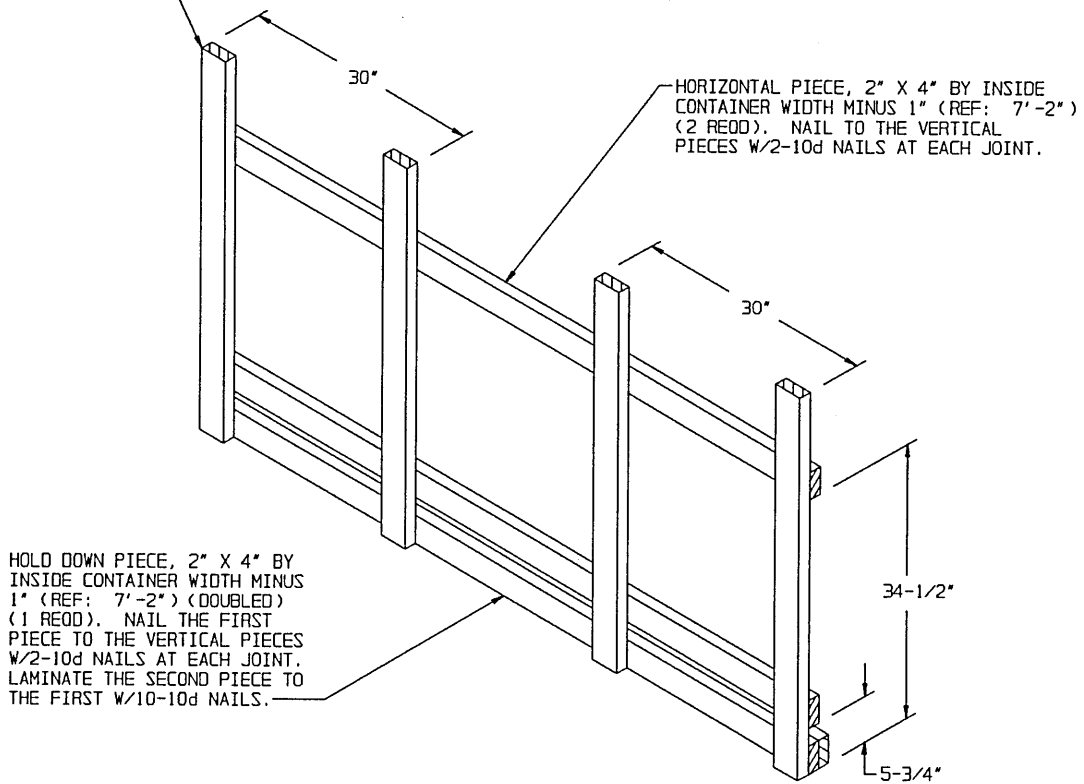

**END BLOCKING ASSEMBLY**

VERTICAL PIECE, 2" X 4" X 48" (DOUBLED) (3 REOD). LAMINATE THE FIRST PIECE TO THE SECOND W/5-10d NAILS.

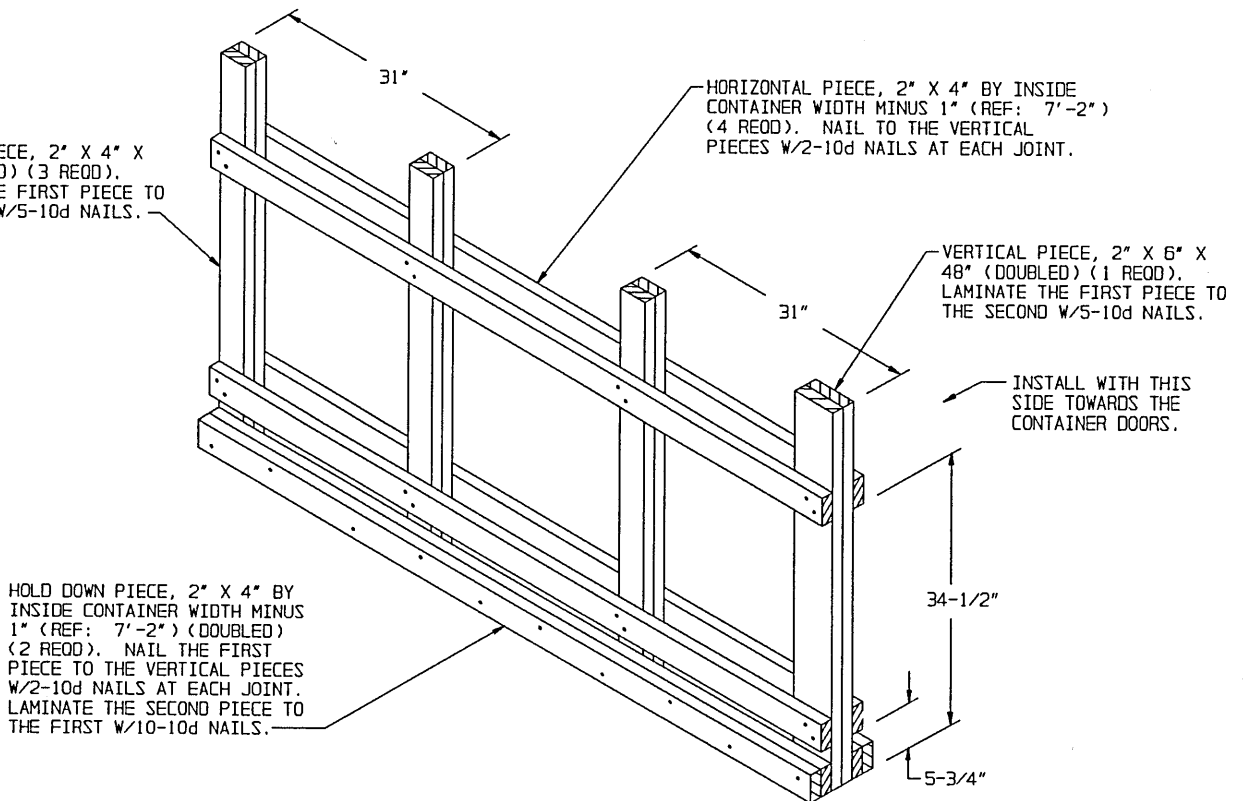

**CENTER FILL ASSEMBLY**

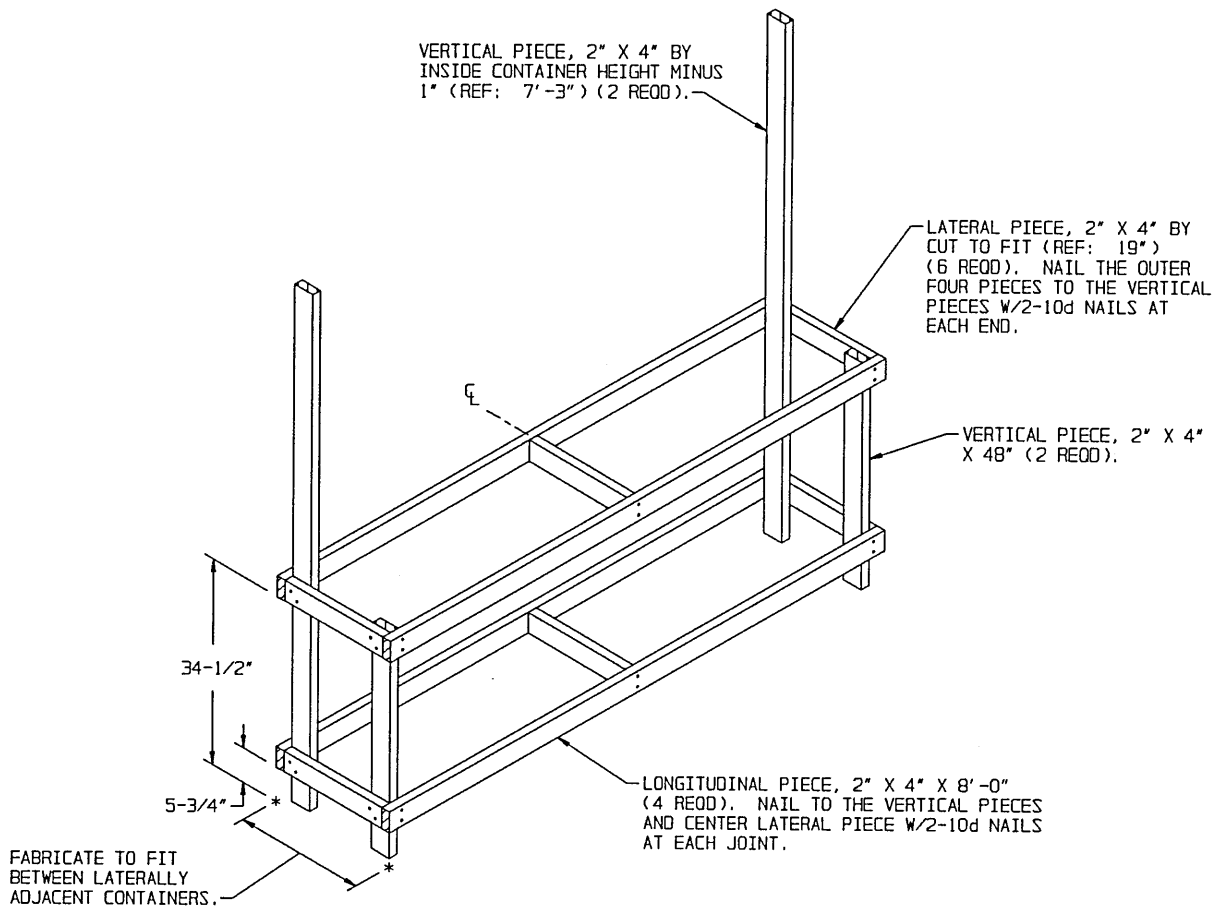

**FILLER ASSEMBLY**

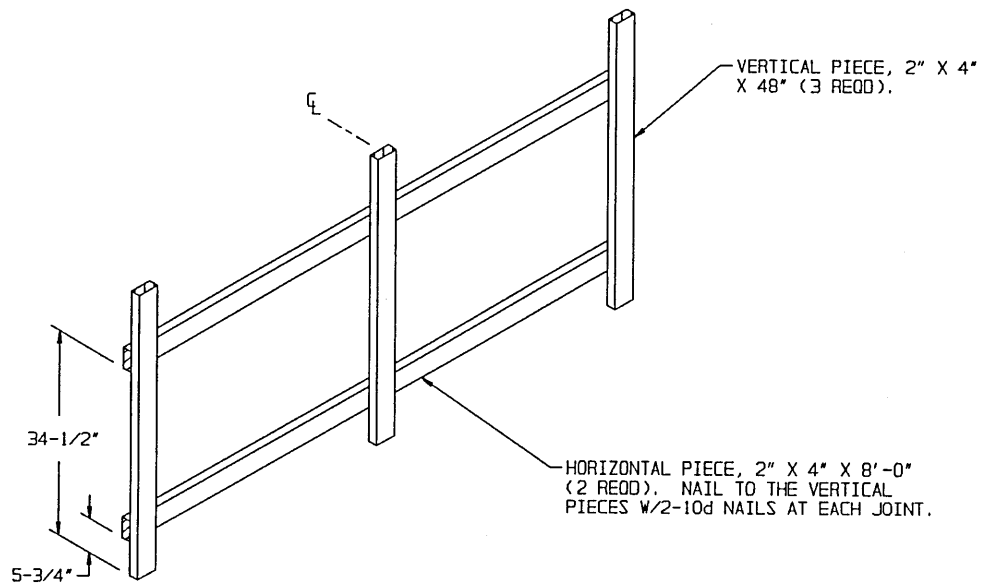

**SIDE FILL ASSEMBLY**

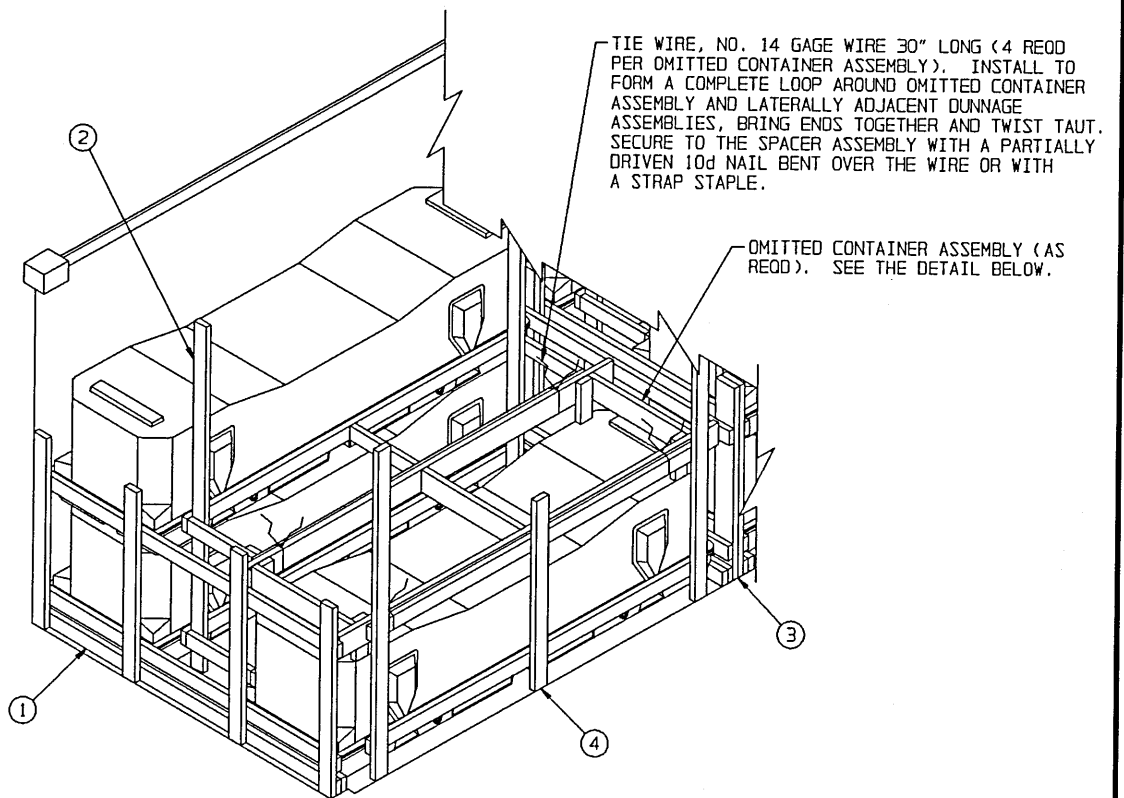

**LESS-THAN-FULL-LOAD PROCEDURE**

THE DETAIL ABOVE DEPICTS A BLOCKING METHOD TO BE USED IN A LESS-THAN-FULL CONTAINER LOAD (LESS THAN EIGHT UNITS). KEY NUMBERS REFER TO KEY NUMBERS ON PAGE 2. ONE OMITTED CONTAINER ASSEMBLY REPLACES ONE CONTAINER. IF FOUR CONTAINERS ARE TO BE OMITTED, OMIT ONE FULL LAYER OF CONTAINERS. SEE GENERAL NOTE "M" ON PAGE 3.

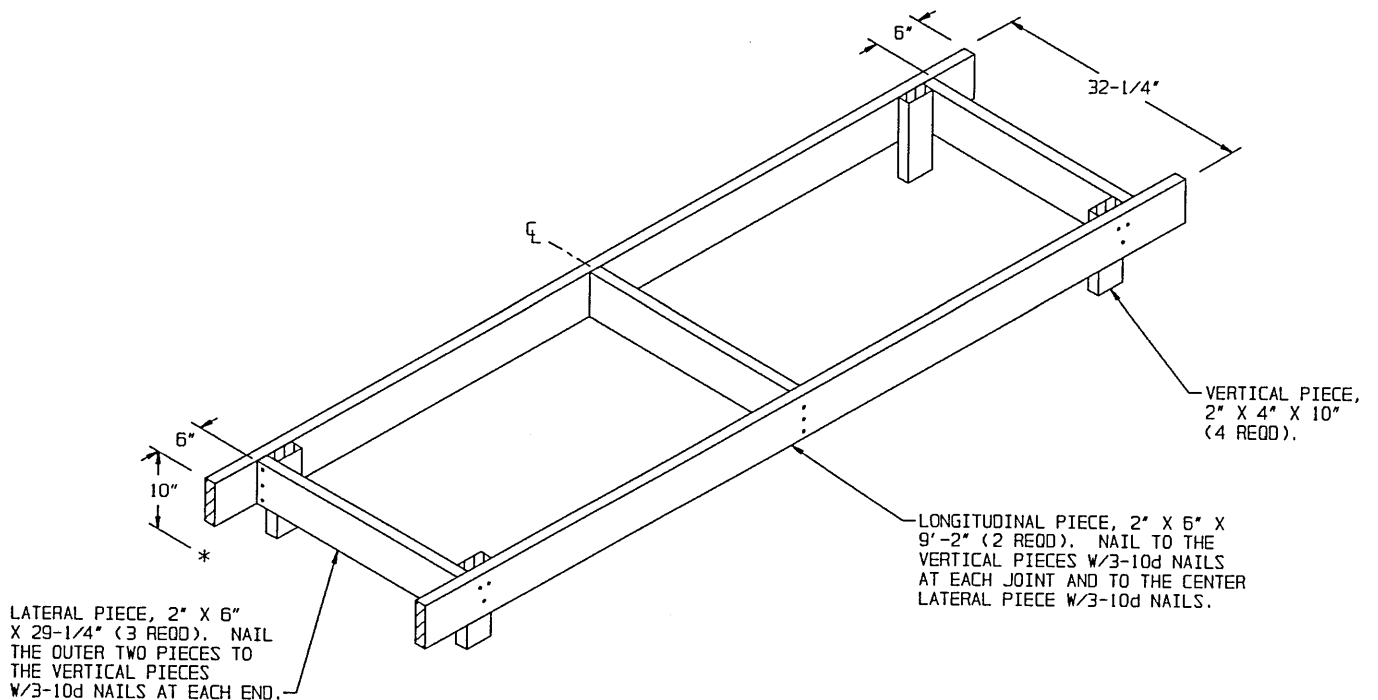

**OMITTED CONTAINER ASSEMBLY**

