

PrSM

LOADING AND BRACING (TL & LTL) ON FLATBED TRAILERS[⊕] OF PRECISION STRIKE MISSILE (PrSM) LAUNCH POD MISSILE CONTAINERS (LPMC)

INDEX

<u>ITEM</u>	<u>PAGE(S)</u>
GENERAL NOTES AND MATERIAL SPECIFICATIONS - - - - -	2
LPMC DETAIL AND SPECIAL HANDLING GUIDANCE - - - - -	3
8 UNIT LOAD ON A 48'-0" LONG BY 8'-6" WIDE FLATBED TRAILER (WEB STRAP TIEDOWN METHOD) - - - - -	4-5
8 UNIT LOAD ON A 45'-0" LONG BY 8'-6" WIDE FLATBED TRAILER (CHAIN TIEDOWN METHOD) - - - - -	6-7
12 UNIT LOAD (EMPTY) ON A 45'-0" LONG BY 8'-6" WIDE FLATBED TRAILER (STEEL STRAPPING METHOD) - - - - -	8-9
TYPICAL LTL (2 UNIT) (STEEL STRAPPING METHOD) - - - - -	10
TYPICAL LTL (1 UNIT) (WEB STRAP TIEDOWN METHOD) - - - - -	11
DETAILS - - - - -	12-13
SPECIAL PROVISIONS FOR WEB STRAP TIEDOWN - - - - -	14
SPECIAL PROVISIONS FOR CHAIN TIEDOWN - - - - -	14
PROVISIONS FOR THE USE OF FIRE HOSE IN LIEU OF CHAIN BOARDS OR STRAPPING BOARDS - - - - -	15

⊕ CAUTION: THE PROCEDURES SHOWN HEREIN ARE ONLY APPLICABLE TO HIGHWAY MOVEMENTS, NOT TRAILER-ON-FLATCAR (TOFC) MOVEMENTS.

U.S. ARMY MATERIEL COMMAND DRAWING

APPROVED, U.S. ARMY AVIATION AND MISSILE COMMAND O'CONNOR.DOUG LAS.LEO.11405822 51 <small>Digitally signed by O'CONNOR.DOUGLAS.LEO.114 0582251 Date: 2023.09.18 10:14:50 -05'00'</small>	CAUTION: VERIFY PRIOR TO USE AT https://www.dau.edu/cop/ammo/Pages/Default.aspx THAT THIS IS THE MOST CURRENT VERSION OF THIS DOCUMENT. THIS IS PAGE 1 OF 16.			
APPROVED BY ORDER OF COMMANDING GENERAL, U.S. ARMY MATERIEL COMMAND BRAILSFORD.KEITH H.ANTHONY.10286 55661 <small>Digitally signed by BRAILSFORD.KEITH.ANTHONY. 1028655661 Date: 2023.10.02 10:17:45 -05'00'</small> DEFENSE AMMUNITION CENTER	DO NOT SCALE	AUGUST 2023		
	DESIGN ENGINEER	BASIC	RICHARD GARSIDE	
	REV.			
	ENGINEERING DIVISON	FIEFFER.LAURA .A.1230375727 <small>Digitally signed by FIEFFER.LAURA.A.1230375727 Date: 2023.08.23 10:09:12 -05'00'</small>		
	TEST ENGINEER	FELICIANO.AD IN.1259200373 <small>Digitally signed by FELICIANO.ADIN.1259200373 Date: 2023.09.30 13:58:35 -05'00'</small>		
	TEST REPORT	NA	CLASS	DIVISION
	EXPLOSIVES SAFETY DIRECTORATE	CUMMINS.PAU L.A.1231883122 <small>Digitally signed by CUMMINS.PAUL.A.1231883122 Date: 2023.09.01 10:12:00 -05'00'</small>	19	48
			DRAWING	FILE
			8263	GM11PS2

GENERAL NOTES

(GENERAL NOTES CONTINUED)

- A. THIS DOCUMENT HAS BEEN PREPARED AND ISSUED IN ACCORDANCE WITH AR 740-1 AND AUGMENTS TM 743-200-1 (CHAPTER 5).
- B. THE SPECIFIED OUTLOADING PROCEDURES ARE APPLICABLE TO THE PRECISION STRIKE MISSILE (PrSM) LAUNCH POD MISSILE CONTAINER (LPMC). SUBSEQUENT REFERENCE TO POD OR CONTAINER HEREIN MEANS THE LPMC WITH MISSILE COMPONENTS. SEE PAGE 3 AND AMCOM DRAWING 13774977 FOR DETAILS.
- C. THE LOADS AS SHOWN HEREIN ARE BASED 45'-0" AND 48'-0" LONG BY 8'-6" WIDE FLATBED TRAILERS. TRAILERS OF OTHER LENGTHS AND WIDTHS MAY BE USED. TRAILERS MUST HAVE WOOD OR WOOD AND METAL FLOORS. TRAILERS HAVING ALL-METAL FLOORS CANNOT BE USED. **CAUTION:** IF THE TRAILER FLOOR IS EQUIPPED WITH EXPOSED METAL DECKING ABOVE THE BOGIE ASSEMBLY, OR ELSEWHERE, FIELD MEASUREMENTS SHOULD BE MADE TO ENSURE THAT THE METAL DECKING DOES NOT INTERFERE WITH THE PROPER POSITIONING AND NAILING OF THE DUNNAGE AS SPECIFIED BY THE PROCEDURES SHOWN HEREIN.
- D. SELECTION OF A VEHICLE FOR THE TRANSPORT OF THE DESIGNATED ITEM IS THE RESPONSIBILITY OF THE ORIGINATING CARRIER AND THE SHIPPER. ONLY VEHICLES IN ACCORDANCE WITH THE REQUIREMENTS OF THE APPLICABLE REGULATORY DOCUMENTS WILL BE SELECTED FOR USE.
- E. GROSS WEIGHT AND AXLE DISTRIBUTION OF WEIGHT FOR A LOAD WILL BE THE RESPONSIBILITY OF THE CARRIER. THE CARRIER WILL ADVISE THE SHIPPER OF APPLICABLE LOADING REQUIREMENTS, AND THE SHIPPER WILL LOAD ACCORDINGLY.
- F. **NOTICE:** A SHIPMENT WILL BE POSITIONED ON A TRAILER CONSISTENT WITH STATE WEIGHT LAWS. THE NUMBER OF UNITS MAY BE ADJUSTED TO FIT THE QUANTITY TO BE SHIPPED; HOWEVER, THE APPROVED METHODS CONTAINED HEREIN MUST BE FOLLOWED AS CLOSELY AS POSSIBLE FOR BLOCKING, BRACING, AND STAYING OF THE DESIGNATED ITEMS.
- G. THE STACK UNITIZING STRAP IS NEEDED WHEN USING WEB STRAPS OR STEEL STRAPS, BUT NOT WITH CHAINS. THE BUNDLING STRAP IS ONLY NEEDED WITH STEEL STRAPS, NOT CHAINS OR WEB STRAPS.
- H. THESE PROCEDURES CAN ALSO BE UTILIZED FOR THE SHIPMENT OF THE CONTAINERS WHEN THEY ARE LOADED WITH AN ITEM WHICH IS IDENTIFIED DIFFERENTLY BY NOMENCLATURE THAN THE ITEM DESIGNATED WITHIN THE DRAWING TITLE, OR WHEN THEY ARE EMPTY.
- J. OTHER TYPES OF LADING ITEMS MAY BE LOADED ON A TRAILER WHICH IS PARTIALLY LOADED WITH THE DESIGNATED ITEM, PROVIDING THE TOTAL LOAD IS COMPATIBLE, EXISTING DIRECTIVES ARE NOT VIOLATED, AND THE OTHER LADING ITEMS ARE BLOCKED AND BRACED TO EQUAL THE BLOCKING AND BRACING CRITERIA SPECIFIED HEREIN.

(CONTINUED AT RIGHT)

- K. **CAUTION:** REGARDLESS OF THE TYPE OF TRAILER INVOLVED, ONLY THOSE TRAILERS HAVING TIEDOWN ANCHORING FACILITIES WHICH PROVIDE HOLDING STRENGTH EQUAL TO OR GREATER THAN THE STRENGTH OF THE HOLD-DOWN STRAPS OR CHAINS AND WHICH ALIGN NEAR THE INDICATED LOCATIONS FOR THE HOLD-DOWN STRAPS OR CHAINS SHOULD BE USED. IF THE TRAILER ANCHOR DEVICES ARE NOT PROPERLY POSITIONED TO RECEIVE STRAPPING OR CHAINS, AS SHOWN, OR IF THE ANCHOR DEVICES ARE NOT EQUAL TO OR GREATER THAN THE STRENGTH OF THE TIEDOWN STRAPS OR CHAINS, STEEL STRAPS MAY BE APPLIED TO FORM A COMPLETE LOOP WHICH ENCOMPASSES BOTH THE LADING AND THE TRAILER FRAME AND/OR BED. **CAUTION:** AVOID TRAILER WHEELS, FIFTH WHEEL PLATE CONTROLS AND OTHER APPURTENANCES. USE EDGE PROTECTORS OR PADS ON ALL SHARP EDGES. NEITHER CHAINS NOR WEB STRAPS WILL BE APPLIED TO FORM A COMPLETE LOOP THAT ENCOMPASSES THE LADING AND THE TRAILER FRAME AND/OR BED.
- L. ALL LOADS ARE SHOWN WITH ALL THE PODS FACING IN THE SAME DIRECTION, THAT IS THE FORWARD END OF ALL PODS TOWARDS THE FORWARD END OF THE TRAILER. THIS IS NECESSARY TO ASSURE PROPER POSITIONING OF THE DUNNAGE PIECES AND HOLD DOWN STRAPS OR CHAINS TO AVOID DAMAGE TO PSM RADIUS BLOCKS.
- M. A STAGGERED NAILING PATTERN WILL BE USED WHEREVER POSSIBLE WHEN NAILS ARE DRIVEN INTO JOINTS OF DUNNAGE ASSEMBLIES. ALSO, A STAGGERED NAILING PATTERN WILL BE USED WHEN DUNNAGE IS NAILED TO THE FLOOR OF THE TRANSPORTING VEHICLE, OR WHEN LAMINATING DUNNAGE. THE NAILING PATTERN WILL BE ADJUSTED AS REQUIRED SO THAT A NAIL DOES NOT PENETRATE INTO OR NEAR A CRACK BETWEEN FLOOR BOARDS. ADDITIONALLY, THE NAILING PATTERN FOR AN UPPER PIECE OF LAMINATED DUNNAGE WILL BE ADJUSTED AS REQUIRED SO THAT A NAIL FOR THAT PIECE WILL NOT BE DRIVEN THROUGH THE PIECE ONTO OR RIGHT BESIDE A NAIL IN A LOWER PIECE.
- N. WHEN STEEL STRAPPING IS SEALED AT AN END-OVER-END LAP JOINT, A MINIMUM OF ONE SEAL WITH TWO PAIR OF NOTCHES WILL BE USED TO SEAL THE JOINT WHEN A NOTCH-TYPE SEALER IS BEING USED. A MINIMUM OF TWO SEALS, BUTTED TOGETHER WITH TWO PAIR OF CRIMPS PER SEAL WILL BE USED TO SEAL THE JOINT WHEN A CRIMP-TYPE SEALER IS BEING USED. REFER TO THE STRAP JOINT DETAILS ON PAGE 13 FOR GUIDANCE.
- O. WHEN LOADING CONTAINERS ON TRAILERS, CARE MUST BE TAKEN TO PROTECT THE RAIL GUIDE BLOCKS. DO NOT INSTALL ANY STRAPPING OR DUNNAGE DIRECTLY AGAINST OR OVER THE RAIL GUIDE BLOCKS. SHIFT AS NECESSARY TO AVOID CONTACT WITH THE BLOCKS.
- P. THE TRANSPORTING VEHICLE OPERATOR SHOULD BE INSTRUCTED TO PERIODICALLY INSPECT THE TIEDOWN CHAINS AND LOAD BINDERS DURING TRANSIT AND TIGHTEN IF NECESSARY.
- Q. FOR ADDITIONAL GUIDANCE, ATTENTION IS DIRECTED TO THE "SPECIAL HANDLING GUIDANCE" ON PAGE 3 AND TO THE "SPECIAL NOTES" SECTIONS IMMEDIATELY ADJACENT TO THE DEPICTED OUTLOADING METHODS.
- R. THE ANTI-CHAFING PIECES, TIE WIRES, SUPPORT PIECES "A", AND SUPPORT PIECES "B" MAY BE OMITTED WHEN THE PODS BEING SHIPPED ARE EQUIPPED WITH THE PROTECTION FOR AIR SHIPMENT DUNNAGE, IAW AMC DRAWING 19-48-5276-GM20MS2. ALL THE PODS WITHIN A LOAD MUST BE EITHER EQUIPPED WITH THE AIR SHIPMENT PROTECTION DUNNAGE, OR NOT EQUIPPED WITH THE DUNNAGE, DO NOT MIX. WHEN A LOAD BAY OF PODS EQUIPPED WITH THE AIR SHIPMENT PROTECTION DUNNAGE IS BEING LOADED, INCREASE THE 5-3/4" DISTANCE FROM THE TRAILER CENTERLINE TO THE PREPOSITIONED SIDE BLOCKING TO 6".
- S. DUNNAGE LUMBER SPECIFIED IS OF NOMINAL SIZE. FOR EXAMPLE, 1" X 4" MATERIAL IS ACTUALLY 3/4" THICK BY 3-1/2" WIDE AND 2" X 6" MATERIAL IS ACTUALLY 1-1/2" THICK BY 5-1/2" WIDE.
- T. CONVERSION TO METRIC EQUIVALENTS: DIMENSIONS WITHIN THIS DOCUMENT ARE EXPRESSED IN INCHES, AND WEIGHTS ARE EXPRESSED IN POUNDS. WHEN NECESSARY, THE METRIC EQUIVALENTS MAY BE COMPUTED ON THE BASIS OF ONE INCH EQUALS 25.4MM, AND ONE POUND EQUALS 0.454 KG.

MATERIAL SPECIFICATIONS

- LUMBER** - - - - - : SEE TM 743-200-1 (DUNNAGE LUMBER) AND VOLUNTARY PRODUCT STANDARD PS 20.
- NAILS** - - - - - : ASTM F1667; COMMON STEEL NAIL (NLCMS OR NLCMS).
- STRAP, WEB, COMMERCIAL** - - - - - : WEB SLING AND TIEDOWN ASSOCIATION RECOMMENDED STANDARD SPECIFICATION FOR SYNTHETIC WEB TIEDOWNS, WSTDA-T-1, REVISED 2005.
- STRAPPING, STEEL** - - - - - : ASTM D3953; FLAT STRAPPING, TYPE 1, HEAVY DUTY, FINISH A, B (GRADE 2), OR C.
- SEAL, STRAP** - - - - - : ASTM D3953; CLASS H, FINISH A, B (GRADE 2), OR C, DOUBLE NOTCH TYPE, STYLE I, II, OR IV.
- STAKE POCKET PROTECTOR** - - - - - : COMMERCIAL GRADE.
- ANTI-CHAFING MATERIAL** - - - - - : MIL-PRF-121 (OR EQUAL); NEUTRAL BARRIER MATERIAL.
- CHAIN** - - - - - : NATIONAL ASSOCIATION OF CHAIN MANUFACTURER'S WELDED CHAIN SPECIFICATION ADOPTED APRIL 2010.
- LOAD BINDER** - - - - - : FED SPEC GG-BG325.
- WIRE, CARBON STEEL** - - - - - : ASTM A853; ANNEALED AT FINISH, BLACK OXIDE FINISH, 0.0800" DIA, GRADE 1006 OR BETTER.

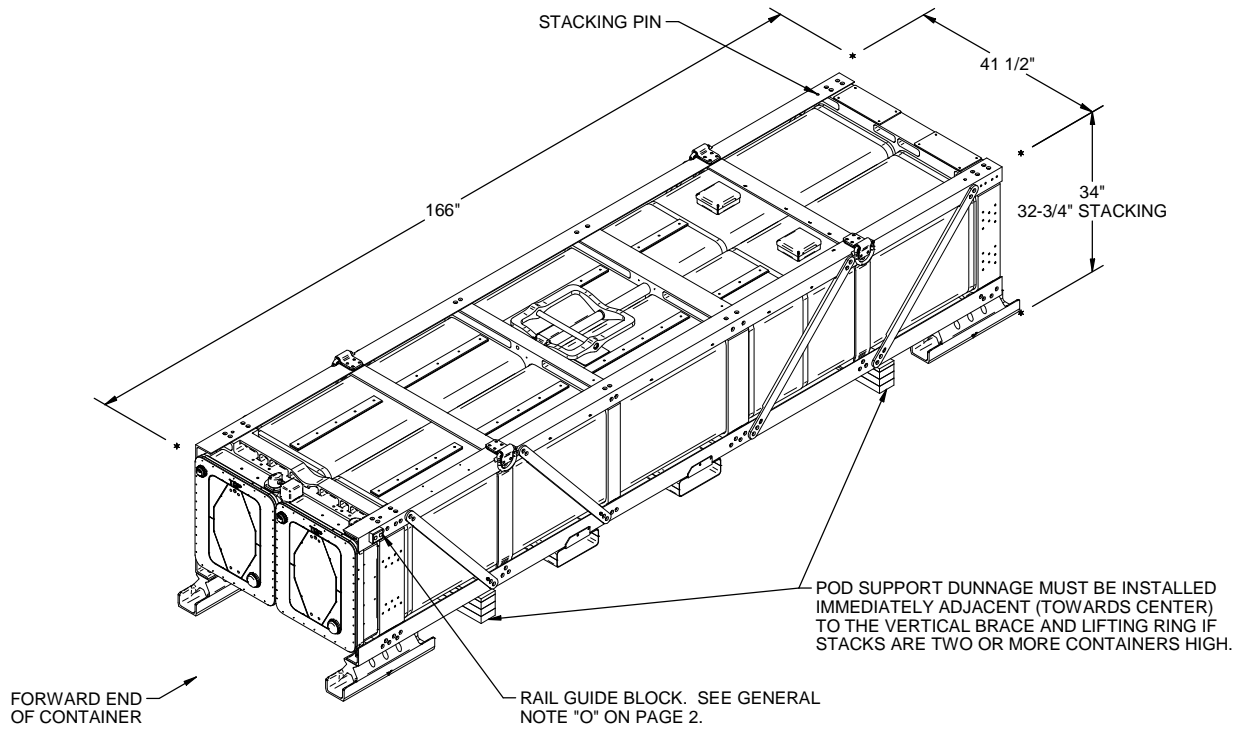

LAUNCH POD MISSILE CONTAINER DATA

GROSS WEIGHT	-----	4,615 LBS (APPROX)
EMPTY WEIGHT	-----	1,353 LBS (APPROX)
CUBE	-----	130.56 CU FT (APPROX)

SPECIAL HANDLING GUIDANCE

- A. WHEN STACKING THESE PODS, CARE MUST BE EXERCISED TO ENSURE THAT THE INTERLOCKING HOLES IN THE BOTTOM OF THE SKIDS ALIGN CORRECTLY WITH THE INTERLOCKING PINS ON THE TOP OF THE FRAME. THIS WILL PRECLUDE DAMAGE TO THE SKIDS AND INSURE PROPER FUNCTIONING OF THE INTERLOCKS.
- B. ONLY APPROVED AND APPROPRIATELY SIZED MATERIAL HANDLING EQUIPMENT WILL BE USED FOR HANDLING THE DEPICTED PODS. APPROVED MATERIAL HANDLING EQUIPMENT (MHE) IS SPECIFIED IN OTHER DOCUMENTS SUCH AS TM 9-1425-646-10. MHE IS INTENDED TO MEAN EQUIPMENT SUCH AS FORKLIFT TRUCKS, CRANES, HAND TRUCKS, DOLLIES, ROLLER ASSEMBLIES, SLINGS, STABILIZING FRAME, AND SPREADER BARS.
- C. PRECAUTIONARY HANDLING TECHNIQUES NORMALLY EMPLOYED OR AS SPECIFIED FOR THE TYPE OF COMMODITY INVOLVED WILL BE OBSERVED.
- D. UNITIZING STRAPS MUST NOT BE APPLIED UNTIL THE SUPPORT "B" ASSEMBLIES ARE IN POSITION. EACH OF THE TWO UNITIZING STRAPS SHOULD BE POSITIONED AROUND THE PODS AS SHOWN, NEAR THE CONTAINER STRONG POINTS (I.E., THE LATERAL FRAME MEMBERS/BULKHEADS). PLACE STRAPPING SO THAT IT LAYS FLAT AND STRAIGHT WITH THE CONTOUR OF THE PODS, I.E., VERTICAL ALONG THE SIDES AND STRAIGHT ACROSS THE TOP AND BOTTOM OF THE STACK.

(CONTINUED AT RIGHT)

(SPECIAL HANDLING GUIDANCE CONTINUED)

- E. PLACE ANTI-CHAFING NEUTRAL BARRIER MATERIAL UNDER THE STRAPPING AT ALL POINTS OF CONTACT WITH THE POD FRAME, IF DESIRED, AND SECURE TO PREVENT DISLODGEEMENT DURING AND AFTER STRAP APPLICATION. STRIPS OF ANTI-CHAFING MATERIAL MAY BE TAPED OR WIRE-TIED TO THE CONTAINER OR STRAPPING, OR IT CAN BE FORMED INTO STRAP ENCIRCLING TUBES BY WINDING MATERIAL AROUND THE STRAPPING TO FORM A SELF-HOLDING UNIT.
- F. STRAPPING WILL BE FIRMLY TENSIONED, AND EACH END-OVER-END LAP JOINT WILL BE SEALED WITH TWO STRAP SEALS AS SHOWN. CRIMP EACH SEAL WITH TWO PAIR OF CRIMPS. SEE GENERAL NOTE "N" ON PAGE 2. THE LAP JOINTS WILL BE MADE ALONG THE SIDE OF THE STACK SO THAT THE SEALS WILL NOT BE IN CONTACT WITH THE PODS. DURING STRAP TENSIONING, CARE SHOULD BE EXERCISED TO ENSURE THAT THE PODS ARE NOT DAMAGED. EXCESS STRAPPING (STRAP ENDS) SHOULD BE CUT OFF OR BROKEN OFF NEAR THE JOINT SEALS.

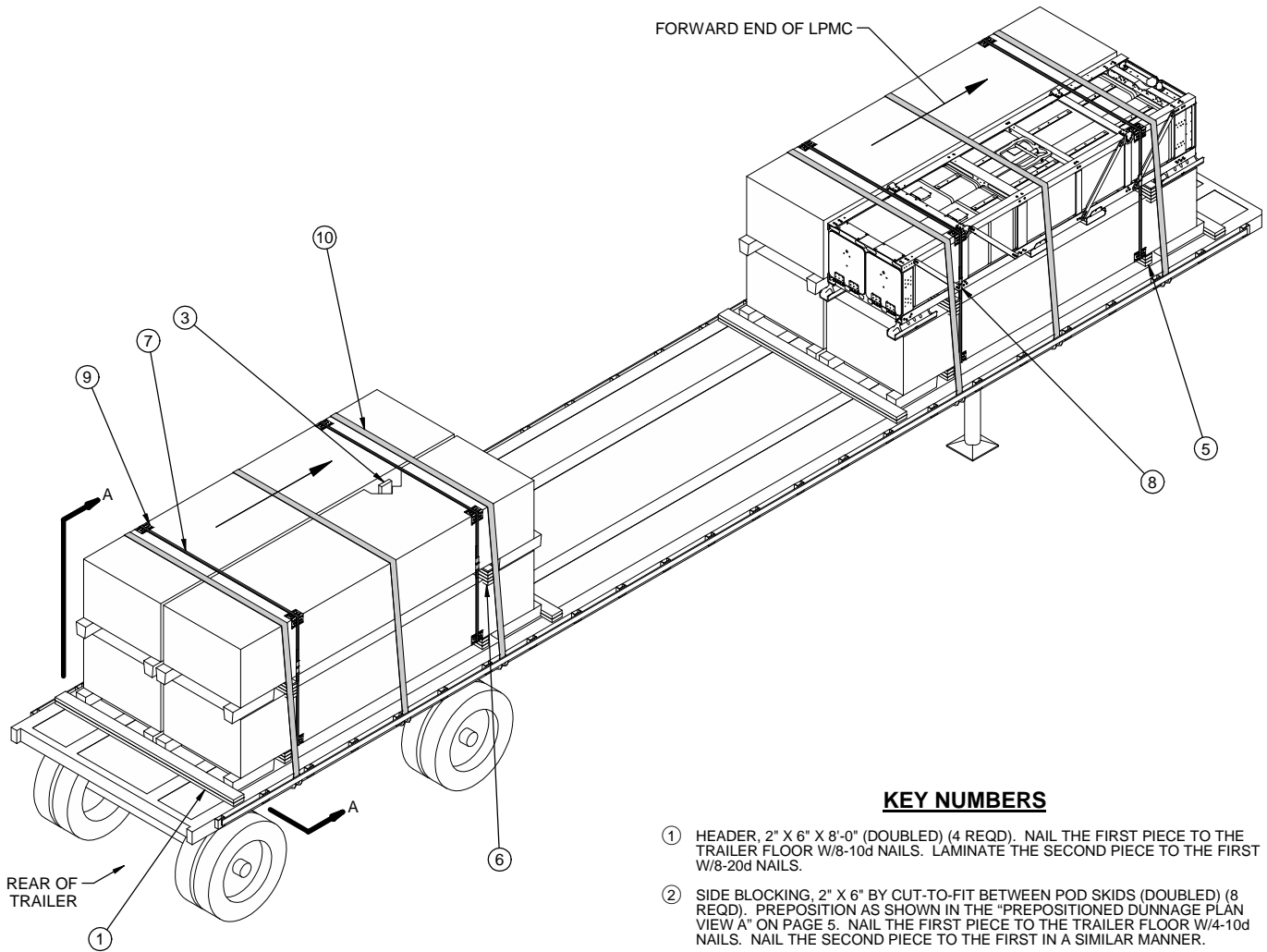

ISOMETRIC VIEW

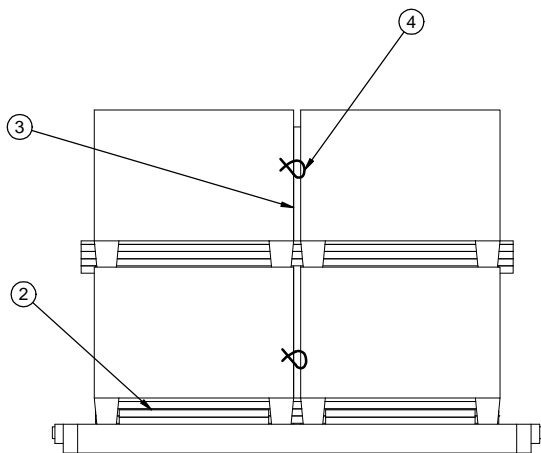

SECTION A-A

STRAPPING OMITTED FOR CLARITY PURPOSES.

KEY NUMBERS

- ① HEADER, 2" X 6" X 8'-0" (DOUBLED) (4 REQD). NAIL THE FIRST PIECE TO THE TRAILER FLOOR W/8-10d NAILS. LAMINATE THE SECOND PIECE TO THE FIRST W/8-20d NAILS.
- ② SIDE BLOCKING, 2" X 6" BY CUT-TO-FIT BETWEEN POD SKIDS (DOUBLED) (8 REQD). PREPOSITION AS SHOWN IN THE "PREPOSITIONED DUNNAGE PLAN VIEW A" ON PAGE 5. NAIL THE FIRST PIECE TO THE TRAILER FLOOR W/4-10d NAILS. NAIL THE SECOND PIECE TO THE FIRST IN A SIMILAR MANNER.
- ③ ANTI-CHAFING, 2" X 4" X 62" (4 REQD). POSITION AS SHOWN AND WIRE TIE TO A VERTICAL FRAME MEMBER OF AN UPPER AND LOWER POD IN ONE POD STACK.
- ④ TIE WIRE, .0800" DIA, 18" LONG (8 REQD). INSTALL THE WIRE TO FORM A COMPLETE LOOP AROUND THE ANTI-CHAFING PIECE AND A VERTICAL FRAME MEMBER OF A POD. BRING ENDS TOGETHER AND TWIST TAUT.
- ⑤ SUPPORT A (4 REQD). PREPOSITION AS SHOWN IN THE "PREPOSITIONED DUNNAGE PLAN VIEW A" ON PAGE 5. NAIL THE FIRST 2" X 4" TO THE TRAILER FLOOR W/6-10d NAILS. NAIL THE REMAINING PIECES ACCORDING TO DETAIL ON PAGE 12.
- ⑥ SUPPORT B (4 REQD). SEE THE DETAIL ON PAGE 12.
- ⑦ STACK UNITIZING STRAP, 1-1/4" X .035" OR .031" X 25'-0" LONG STEEL STRAPPING (4 REQD, 2 PER STACK). INSTALL TO ENCIRCLE ALL FOUR PODS IN A LOAD BAY. SEE THE "SPECIAL HANDLING GUIDANCE" ON PAGE 3.
- ⑧ SEAL FOR 1-1/4" STEEL STRAPPING (8 REQD, 2 PER STRAP). DOUBLE CRIMP EACH SEAL. SEE GENERAL NOTE "N" ON PAGE 2.
- ⑨ ANTI-CHAFING NEUTRAL BARRIER MATERIAL (AS REQD). POSITION UNDER ALL STACK UNITIZING STRAPS AT POINTS OF CONTACT WITH THE POD.
- ⑩ WEB STRAP ASSEMBLY (6 REQD). POSITION TO EXTEND FROM A WINCH ON ONE SIDE OF THE TRAILER, OVER THE CONTAINERS, TO AN ATTACHMENT POINT ON THE OPPOSITE SIDE. SEE THE "SPECIAL PROVISIONS FOR WEB STRAP TIEDOWN" ON PAGE 14.

SPECIAL NOTES:

1. AN 8 UNIT LOAD IS SHOWN ON A 48'-0" LONG BY 8'-6" WIDE FLATBED TRAILER. OTHER LENGTH AND WIDTH TRAILERS MAY BE USED.
2. ALL STRAPS AND SUPPORTS MUST BE INSTALLED NEAR THE STRONG POINTS OR VERTICALLY REINFORCED AREAS OF THE PODS AS SHOWN IN THE LOAD VIEWS ON PAGE 4.
3. IF CHAINS AND LOAD BINDERS ARE TO BE USED FOR LOAD SECUREMENT IN LIEU OF THE WEB STRAPPING, REFER TO THE PROCEDURES ON PAGES 6 AND 7 FOR GUIDANCE. IF STEEL STRAPS ARE TO BE USED FOR LOAD SECUREMENT, REFER TO THE PROCEDURES ON PAGES 8 AND 9 FOR GUIDANCE.
4. THE DEPICTED LOAD CAN BE REDUCED TO SUIT THE QUANTITY TO BE SHIPPED. SEE THE DETAILS ON PAGES 6, 10 AND 11 FOR OTHER LOADING CONFIGURATIONS AND QUANTITIES.
5. THE LOAD DEPICTED ON PAGE 4 CAN BE SHIPPED ON A DROP-FRAME TRAILER BY PLACING THE FORWARD HEADER AND FORWARD POD STACKS AGAINST THE DROP-FRAME WALL OF THE TRAILER.

(SPECIAL NOTES CONTINUED)

6. THE DIMENSIONS SHOWN IN THE "PREPOSITIONED DUNNAGE PLAN VIEW A" BELOW ARE BASED UPON THE LOAD SIDE OF THE HEADERS BEING LOCATED 21" FROM THE END OF THE TRAILER.
7. PREPOSITION THE SIDE BLOCKING PIECES AND THE SUPPORT "A" PIECES AS SHOWN IN THE "PREPOSITIONED DUNNAGE PLAN VIEW A" BELOW.
8. DO NOT PREPOSITION THE END HEADERS. INSTALL THESE HEADERS AFTER THE PODS HAVE BEEN LOADED. PLACE THE HEADERS TIGHT AGAINST THE POD SKIDS.
9. IF THE DEPICTED LOAD CONFIGURATION IS TO BE SHIPPED ON A 40' LONG FLATBED TRAILER, THE PREPOSITIONED PIECES SHOULD BE LOCATED AT 24'-3/4", 51'-3/4", 11'-11-1/4", AND 14'-1/4" FROM THE FIRST STAKE POCKET AT THE FRONT AND REAR OF THE TRAILER.
10. SUPPORT "A" MAY BE PREASSEMBLED, IF DESIRED; TOENAIL TO THE TRAILER FLOOR W/4-10d NAILS ON EACH SIDE.

(CONTINUED AT RIGHT)

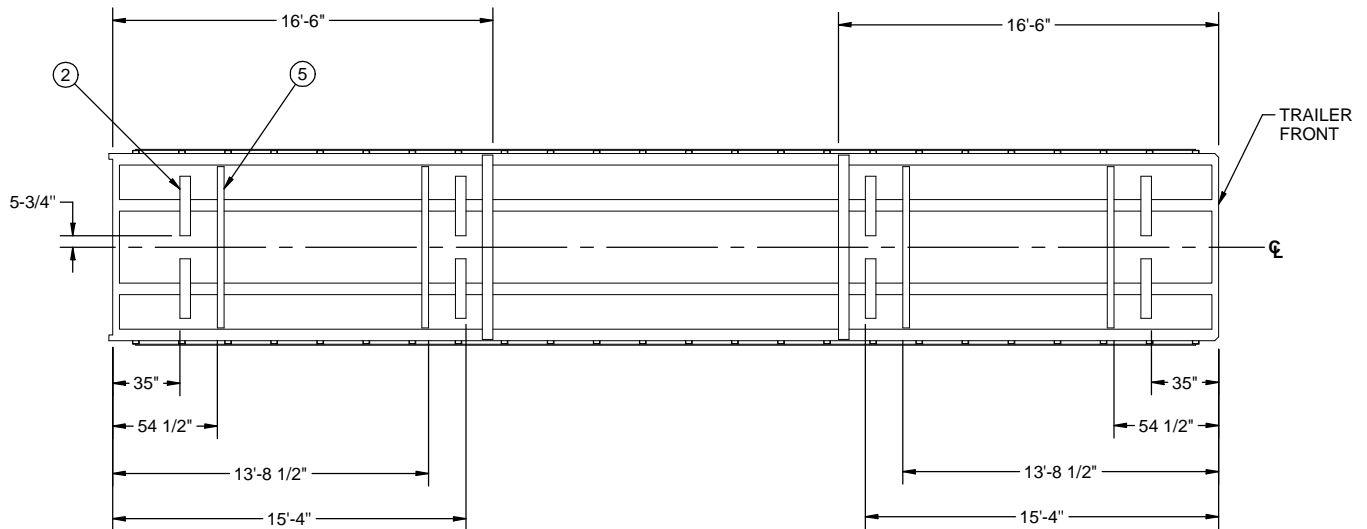

PREPOSITIONED DUNNAGE PLAN VIEW A
KEY NUMBERS REFER TO KEY NUMBERS ON PAGE 4

BILL OF MATERIAL		
LUMBER	LINEAR FEET	BOARD FEET
1" x 4"	58	19
2" x 4"	197	131
2" x 6"	106	106
NAILS	NO. REQD	POUNDS
6d (2")	64	1/4
10d (3")	264	4-1/4
20d (4")	32	1-1/4
STEEL STRAPPING, 1-1/4" - 100' REQD - 14-1/2 LBS		
SEAL FOR 1-1/4" STRAPPING - 8 REQD - 1/2 LBS		
ANTI-CHAFING MATERIAL - 16 REQD - 1-1/2 LBS		
WEB STRAP ASSEMBLY - 6 REQD		
WIRE, .0800" DIAMETER - 12' REQD - 1/4 LB		

LOAD AS SHOWN

ITEM	QUANTITY	WEIGHT (APPROX)
PrSM LPMC	8	36,920 LBS
DUNNAGE		534 LBS
TOTAL WEIGHT		37,454 LBS (APPROX)

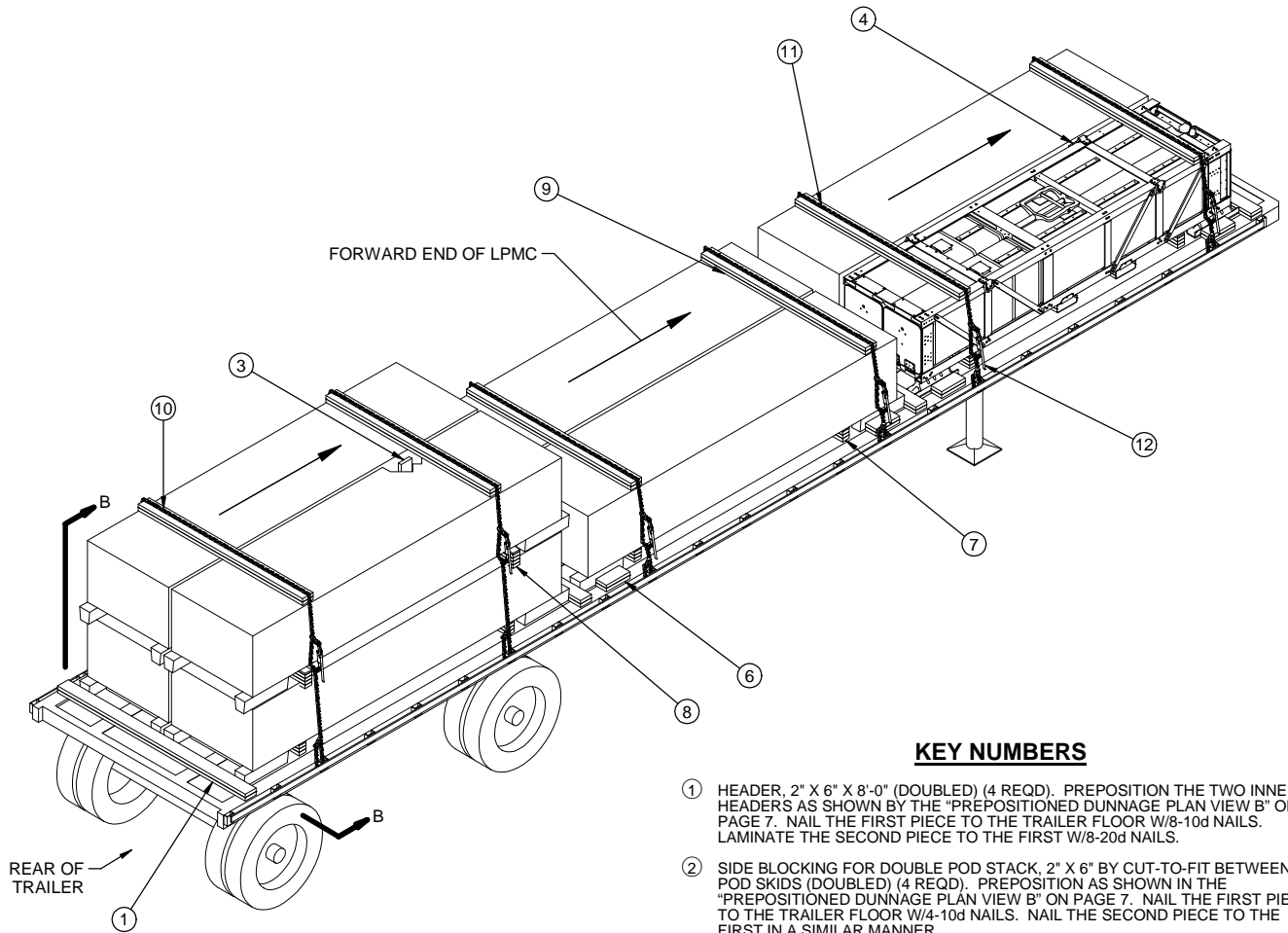

ISOMETRIC VIEW

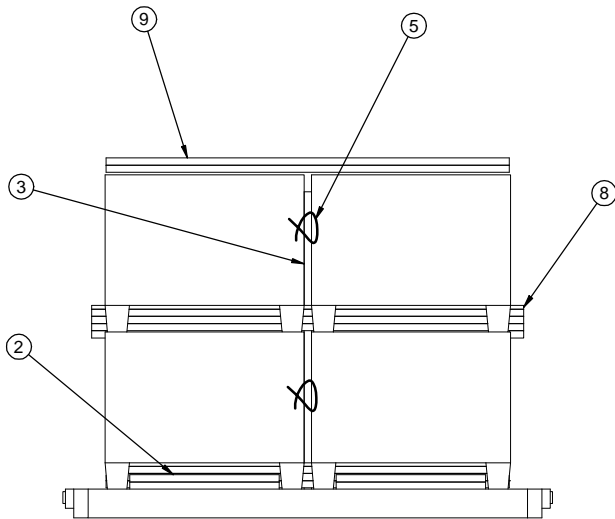

SECTION B-B

STRAPPING OMITTED FOR CLARITY PURPOSES.

KEY NUMBERS

- ① HEADER, 2" X 6" X 8'-0" (DOUBLED) (4 REQD). PREPOSITION THE TWO INNER HEADERS AS SHOWN BY THE "PREPOSITIONED DUNNAGE PLAN VIEW B" ON PAGE 7. NAIL THE FIRST PIECE TO THE TRAILER FLOOR W/8-10d NAILS. LAMINATE THE SECOND PIECE TO THE FIRST W/8-20d NAILS.
- ② SIDE BLOCKING FOR DOUBLE POD STACK, 2" X 6" BY CUT-TO-FIT BETWEEN POD SKIDS (DOUBLED) (4 REQD). PREPOSITION AS SHOWN IN THE "PREPOSITIONED DUNNAGE PLAN VIEW B" ON PAGE 7. NAIL THE FIRST PIECE TO THE TRAILER FLOOR W/4-10d NAILS. NAIL THE SECOND PIECE TO THE FIRST IN A SIMILAR MANNER.
- ③ ANTI-CHAFING, 2" X 4" X 62" (2 REQD). POSITION AS SHOWN AND WIRE TIE TO A VERTICAL FRAME MEMBER OF AN UPPER AND LOWER POD IN ONE POD STACK.
- ④ ANTI-CHAFING, 2" X 4" X 31" (4 REQD). POSITION AS SHOWN AND WIRE TIE TO A VERTICAL FRAME MEMBER OF ONE POD AT TWO LOCATIONS.
- ⑤ TIE WIRE, .0800" DIA, 18" LONG (12 REQD). INSTALL THE WIRE TO FORM A COMPLETE LOOP AROUND THE ANTI-CHAFING PIECE AND A VERTICAL FRAME MEMBER OF A POD. BRING ENDS TOGETHER AND TWIST TAUT.
- ⑥ SIDE BLOCKING FOR SINGLE POD STACK, 2" X 6" X 12" (DOUBLED) (8 REQD). THIS EXTERNAL SIDE BLOCKING CAN NOT BE USED ON NARROWER TRAILERS (LESS THAN 8'-6") AND IS LIMITED TO USE ON ONE HIGH SECTIONS. POSITION AGAINST A POD SKID AND NAIL THE FIRST PIECE TO THE TRAILER FLOOR W/3-10d NAILS. LAMINATE THE SECOND PIECE TO THE FIRST IN A SIMILAR MANNER.
- ⑦ SUPPORT A (6 REQD). PREPOSITION AS SHOWN IN THE "PREPOSITIONED DUNNAGE PLAN VIEW B" ON PAGE 7. NAIL THE FIRST 2" X 4" TO THE TRAILER FLOOR W/6-10d NAILS. NAIL THE REMAINING PIECES ACCORDING TO DETAIL ON PAGE 12.
- ⑧ SUPPORT B (2 REQD). SEE THE DETAIL ON PAGE 12.
- ⑨ CHAIN BOARD, 2" X 6" X 7'-0" (DOUBLED) (6 REQD). NAIL THE SECOND PIECE TO THE FIRST W/6-10d NAILS. SEE SPECIAL NOTE 8 ON PAGE 7.
- ⑩ CHAIN, BINDING, 5/16" OR 3/8", GRADE 70 BY A LENGTH TO SUIT (REF: 22) (2 REQD). POSITION AS SHOWN, ATTACHED TO A STAKE POCKET. DO NOT ATTACH TO RUB RAIL. SEE THE "SPECIAL PROVISIONS FOR CHAIN TIEDOWN" ON PAGE 14.
- ⑪ CHAIN, BINDING, 5/16" OR 3/8", GRADE 70 BY A LENGTH TO SUIT (REF: 16') (4 REQD). POSITION AS SHOWN, ATTACHED TO A STAKE POCKET. DO NOT ATTACH TO RUB RAIL. SEE THE "SPECIAL PROVISIONS FOR CHAIN TIEDOWN" ON PAGE 14.
- ⑫ LOAD BINDER, 5/16" OR 3/8", OVER-CENTER TYPE (6 REQD, 1 PER CHAIN). WIRE TIE HANDLE TO PREVENT OPENING DURING TRANSPORT. FASTEN THE TENSIONED CHAIN TO THE CHAIN BOARD W/1-20d NAIL AT EACH END, BY DRIVING EACH NAIL INTO THE CHAIN BOARD THRU AN OPENING IN A CHAIN LINK AND BENDING IT OVER THE LINK.

SPECIAL NOTES:

1. AN 8 UNIT LOAD IS SHOWN ON A 45'-0" LONG BY 8'-6" WIDE FLATBED TRAILER. OTHER LENGTH AND WIDTH TRAILERS MAY BE USED.
2. ALL CHAINS AND SUPPORTS MUST BE INSTALLED NEAR THE STRONG POINTS OR VERTICALLY REINFORCED AREAS OF THE PODS AS SHOWN IN THE LOAD VIEWS ON PAGE 6.
3. IF WEB STRAPS ARE TO BE USED FOR LOAD SECUREMENT IN LIEU OF THE CHAINS AND LOAD BINDERS, REFER TO THE PROCEDURES ON PAGES 4 AND 5 FOR GUIDANCE. IF STEEL STRAPS ARE TO BE USED FOR LOAD SECUREMENT, REFER TO THE PROCEDURES ON PAGES 8 AND 9 FOR GUIDANCE.
4. THE DEPICTED LOAD CAN BE REDUCED TO SUIT THE QUANTITY TO BE SHIPPED. SEE THE DETAILS ON PAGES 4, 10 AND 11 FOR OTHER LOADING CONFIGURATIONS AND QUANTITIES.
5. THE DIMENSIONS SHOWN IN THE "PREPOSITIONED DUNNAGE PLAN VIEW B" BELOW ARE BASED UPON THE LOAD SIDE OF THE HEADERS BEING LOCATED 10" FROM THE END OF THE TRAILER.

(SPECIAL NOTES CONTINUED)

6. PREPOSITION THE INSIDE HEADERS, THE SIDE BLOCKING PIECES FOR DOUBLE POD STACK AND THE SUPPORT "A" PIECES AS SHOWN IN THE "PREPOSITIONED DUNNAGE PLAN VIEW B" BELOW.
7. DO NOT PREPOSITION THE FRONT AND REAR HEADERS OR THE SIDE BLOCKING PIECES FOR SINGLE POD STACK. INSTALL THESE PIECES AFTER THE PODS HAVE BEEN LOADED. PLACE THESE PIECES TIGHT AGAINST THE POD SKIDS.
8. THE CHAIN BOARD MUST REST ON THE TOP OF POD AND SHALL BE GREATER THAN 12" BUT LESS THAN 60" FROM THE END OF A POD. THE CHAINS MUST BE ATTACHED TO THE STAKE POCKETS. **CAUTION:** THE CHAIN AND PURCHASE BOARDS, AND CHAIN ASSEMBLIES MUST BE IN VERTICAL ALIGNMENT WITH THE TRAILER STAKE POCKET PROVISIONS. SHIFT THE LOAD FORE OR AFT AS NECESSARY TO ACCOMMODATE VARIATIONS IN STAKE POCKET LOCATIONS.
9. SUPPORT "A" MAY BE PREASSEMBLED, IF DESIRED; TOENAIL TO THE TRAILER FLOOR W/4-10d NAILS ON EACH SIDE.

(CONTINUED AT RIGHT)

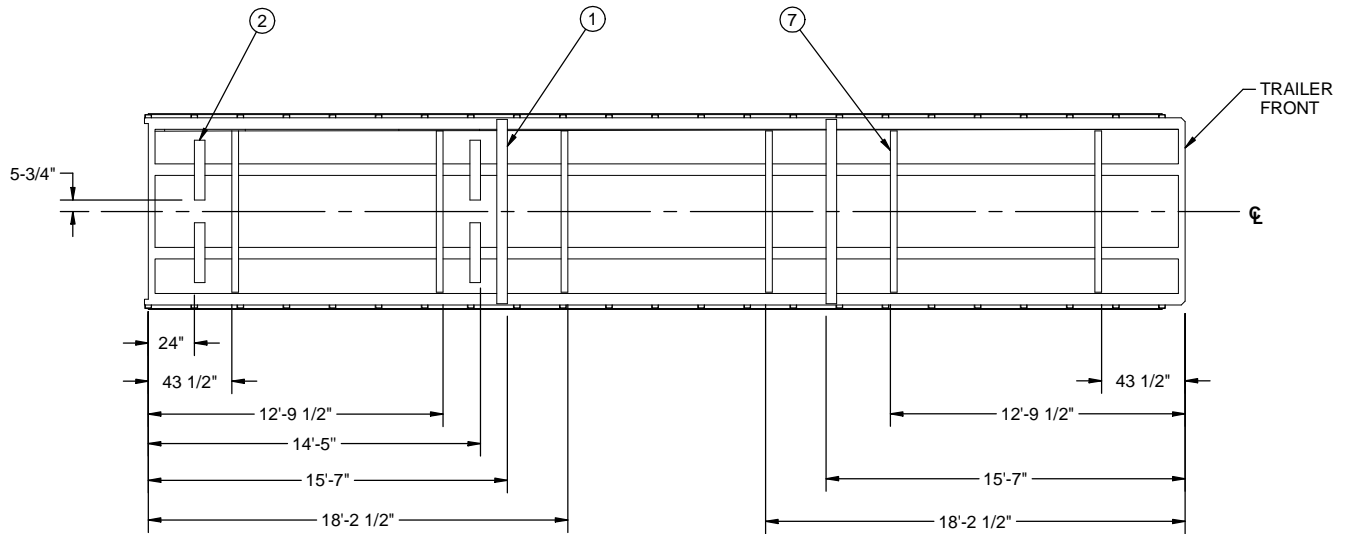

PREPOSITIONED DUNNAGE PLAN VIEW B
KEY NUMBERS REFER TO KEY NUMBERS ON PAGE 6

BILL OF MATERIAL		
LUMBER	LINEAR FEET	BOARD FEET
1" x 4"	57	19
2" x 4"	193	128
2" x 6"	185	185
NAILS	NO. REQD	POUNDS
6d (2")	64	1/4
10d (3")	320	5
20d (4")	32	1-1/4
CHAIN, BINDING, 5/16"	-- 108' REQD	-- 130 LBS
BINDER, LOAD	-- 6 REQD	-- 36 LBS
WIRE, .0800" DIAMETER	-- 18' REQD	-- 1/2 LB

LOAD AS SHOWN

ITEM	QUANTITY	WEIGHT (APPROX)
PrSM LPMC	8	36,920 LBS
DUNNAGE		837 LBS
TOTAL WEIGHT		37,757 LBS (APPROX)

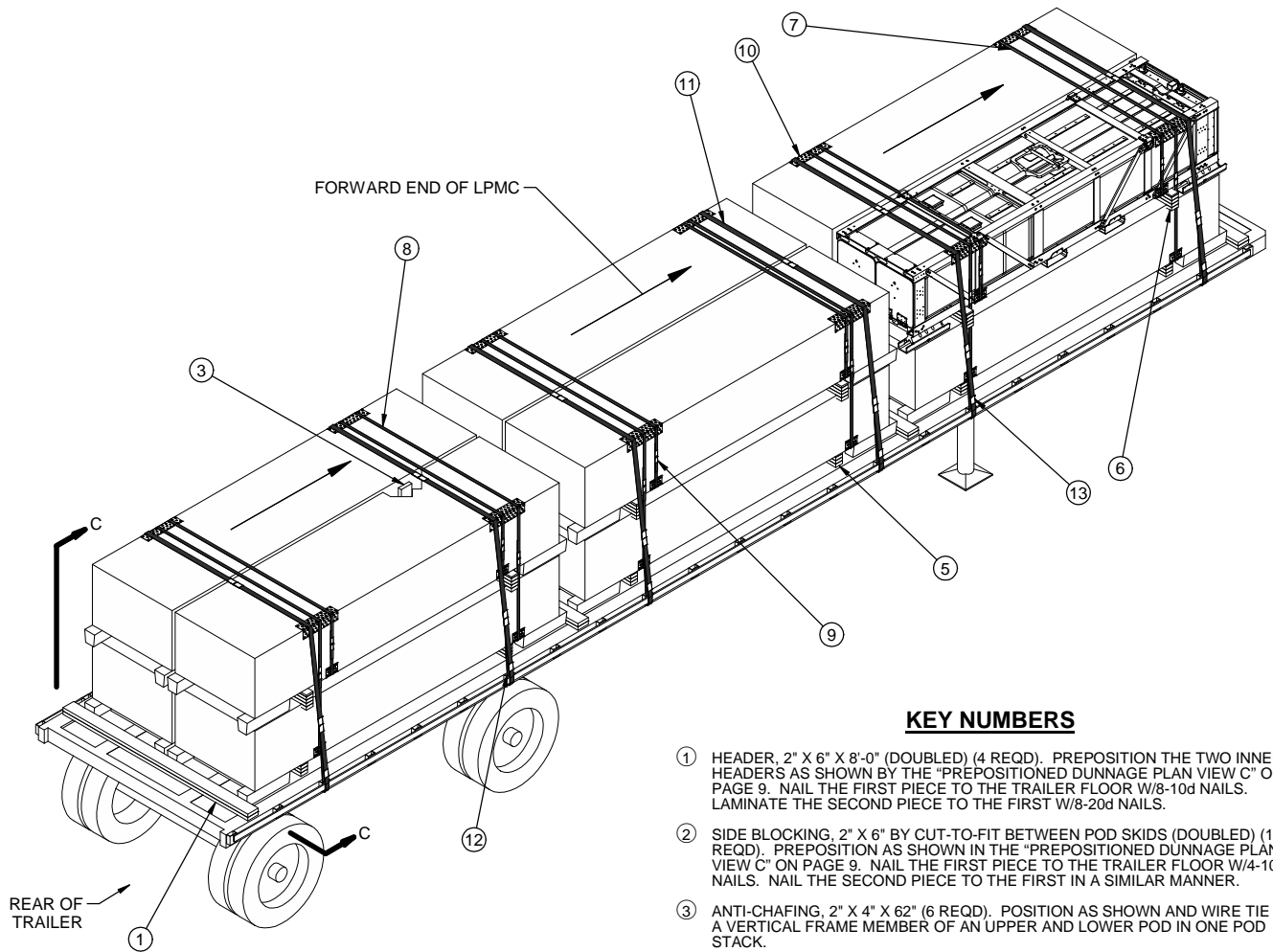

ISOMETRIC VIEW

KEY NUMBERS

- ① HEADER, 2" X 6" X 8'-0" (DOUBLED) (4 REQD). PREPOSITION THE TWO INNER HEADERS AS SHOWN BY THE "PREPOSITIONED DUNNAGE PLAN VIEW C" ON PAGE 9. NAIL THE FIRST PIECE TO THE TRAILER FLOOR W/8-10d NAILS. LAMINATE THE SECOND PIECE TO THE FIRST W/8-20d NAILS.
- ② SIDE BLOCKING, 2" X 6" BY CUT-TO-FIT BETWEEN POD SKIDS (DOUBLED) (12 REQD). PREPOSITION AS SHOWN IN THE "PREPOSITIONED DUNNAGE PLAN VIEW C" ON PAGE 9. NAIL THE FIRST PIECE TO THE TRAILER FLOOR W/4-10d NAILS. NAIL THE SECOND PIECE TO THE FIRST IN A SIMILAR MANNER.
- ③ ANTI-CHAFING, 2" X 4" X 62" (6 REQD). POSITION AS SHOWN AND WIRE TIE TO A VERTICAL FRAME MEMBER OF AN UPPER AND LOWER POD IN ONE POD STACK.
- ④ TIE WIRE, .0800" DIA, 18" LONG (12 REQD). INSTALL THE WIRE TO FORM A COMPLETE LOOP AROUND THE ANTI-CHAFING PIECE AND A VERTICAL FRAME MEMBER OF A POD. BRING ENDS TOGETHER AND TWIST TAUT.
- ⑤ SUPPORT A (6 REQD). PREPOSITION AS SHOWN IN THE "PREPOSITIONED DUNNAGE PLAN VIEW C" ON PAGE 9. NAIL THE FIRST 2" X 4" TO THE TRAILER FLOOR W/6-10d NAILS. NAIL THE REMAINING PIECES ACCORDING TO DETAIL ON PAGE 12.
- ⑥ SUPPORT B (6 REQD). SEE THE DETAIL ON PAGE 12.
- ⑦ BUNDLING STRAP, 1-1/4" X .035" OR .031" X 19'-6" LONG STEEL STRAPPING (6 REQD). INSTALL TO ENCIRCLE LATERALLY ADJACENT PODS IN THE TOP LAYER AS SHOWN.
- ⑧ STACK UNITIZING STRAP, 1-1/4" X .035" OR .031" X 25'-0" LONG STEEL STRAPPING (6 REQD, 2 PER STACK). INSTALL TO ENCIRCLE ALL FOUR PODS IN A LOAD BAY. SEE THE "SPECIAL HANDLING GUIDANCE" ON PAGE 3 AND SPECIAL NOTE 5 ON PAGE 9.
- ⑨ SEAL FOR 1-1/4" STEEL STRAPPING (24 REQD, 2 PER STRAP). DOUBLE CRIMP EACH SEAL. SEE GENERAL NOTE "N" ON PAGE 2.
- ⑩ ANTI-CHAFING NEUTRAL BARRIER MATERIAL (AS REQD). POSITION UNDER ALL STRAPS AT POINTS OF CONTACT WITH THE POD.
- ⑪ HOLD-DOWN STRAP, 2" X .050" OR .044" X 27'-6" LONG STEEL STRAPPING (6 REQD). INSTALL EACH STRAP FROM TWO 13'-9" LONG PIECES. STAPLE TO THE STRAPPING BOARD W/2 STAPLES. DO NOT OVERTENSION THE HOLD-DOWN STRAP.
- ⑫ PAD, 2" X .050" OR .044" X 18" LONG STEEL STRAPPING (12 REQD). POSITION BETWEEN THE HOLD-DOWN STRAP AND THE TRAILER STAKE POCKET AND SEAL TO THE HOLD-DOWN STRAP. SEE "DETAIL A" ON PAGE 13. ALT: STAKE POCKET PROTECTOR (24 REQD). USE TWO UNDER EACH ANCHORING FACILITY WITH A HOLD-DOWN STRAP. SEE "DETAIL B" ON PAGE 13.
- ⑬ SEAL FOR 2" STEEL STRAPPING (48 REQD, 8 PER STRAP). DOUBLE CRIMP EACH SEAL, EXCEPT THOSE USED TO SECURE THE PADS. SEE GENERAL NOTE "N" ON PAGE 2.

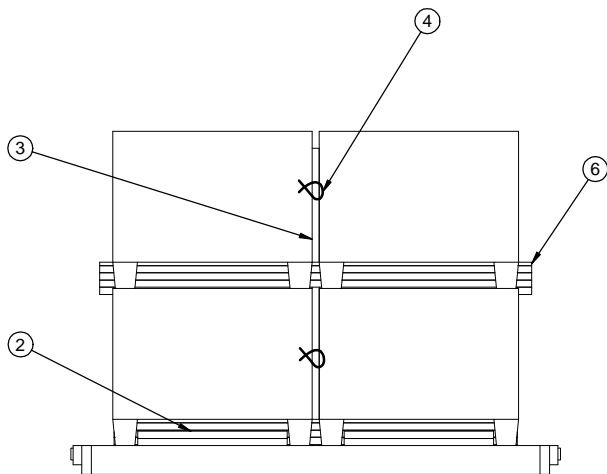

SECTION C-C

STRAPPING OMITTED FOR CLARITY PURPOSES.

SPECIAL NOTES:

1. A 12 UNIT LOAD (EMPTY) IS SHOWN ON A 45'-0" LONG BY 8'-6" WIDE FLAT-BED TRAILER. OTHER LENGTH AND WIDTH TRAILERS MAY BE USED.
2. ALL STRAPS AND SUPPORTS MUST BE INSTALLED NEAR THE STRONG POINTS OR VERTICALLY REINFORCED AREAS OF THE PODS AS SHOWN IN THE LOAD VIEWS ON PAGE 8.
3. IF WEB STRAPS ARE TO BE USED FOR LOAD SECUREMENT IN LIEU OF THE STEEL HOLD-DOWN STRAPS, REFER TO THE PROCEDURES ON PAGES 4 AND 5 FOR GUIDANCE. IF CHAINS AND LOAD BINDERS ARE TO BE USED FOR LOAD SECUREMENT, REFER TO THE PROCEDURES ON PAGES 6 AND 7 FOR GUIDANCE.
4. THE DEPICTED LOAD CAN BE REDUCED TO SUIT THE QUANTITY TO BE SHIPPED. SEE THE DETAILS ON PAGES 4, 6, 10 AND 11 FOR OTHER LOADING CONFIGURATIONS AND QUANTITIES.
5. **CAUTION:** THE LOAD BUNDLING STRAPS MUST BE INSTALLED WITH CARE SO AS NOT TO HAVE EDGE-TO-EDGE CONTACT WITH THE STACK UNITIZING STRAPS.

(CONTINUED AT RIGHT)

(SPECIAL NOTES CONTINUED)

6. THE DIMENSIONS SHOWN IN THE "PREPOSITIONED DUNNAGE PLAN VIEW C" BELOW ARE BASED UPON THE LOAD SIDE OF THE HEADERS BEING LOCATED 10" FROM THE END OF THE TRAILER.
7. PREPOSITION THE INSIDE HEADERS, THE SIDE BLOCKING PIECES AND THE SUPPORT "A" PIECES AS SHOWN IN THE "PRE-POSITIONED DUNNAGE PLAN VIEW C" BELOW.
8. DO NOT PREPOSITION THE END HEADERS. INSTALL THESE HEADERS AFTER THE PODS HAVE BEEN LOADED. PLACE THESE HEADERS TIGHT AGAINST THE POD SKIDS.
9. THE STRAPPING BOARD MUST REST ON THE TOP OF POD AND SHALL BE GREATER THAN 12" BUT LESS THAN 60" FROM THE END OF A POD. **CAUTION:** THE STRAPPING BOARDS AND HOLD-DOWN STRAPS MUST BE IN VERTICAL ALIGNMENT WITH THE TRAILER STAKE POCKET PROVISIONS. SHIFT THE LOAD FORE OR AFT AS NECESSARY TO ACCOMMODATE VARIATIONS IN STAKE POCKET LOCATIONS.
10. SUPPORT "A" MAY BE PREASSEMBLED, IF DESIRED; TOENAIL TO THE TRAILER FLOOR W/4-10d NAILS ON EACH SIDE.

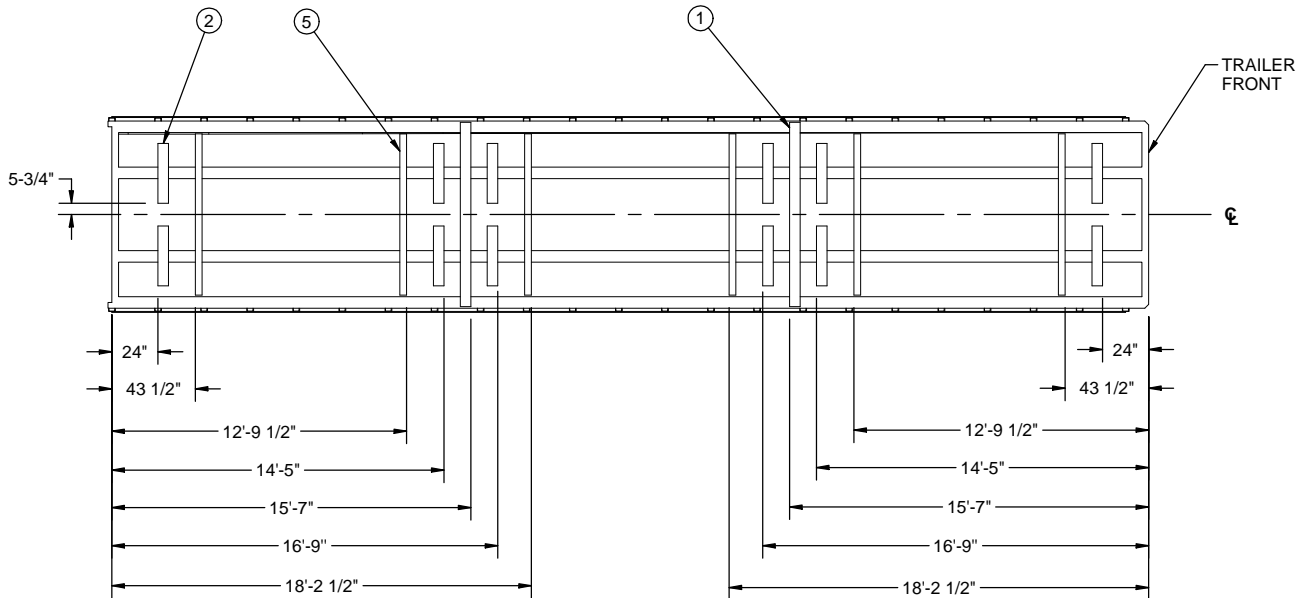

PREPOSITIONED DUNNAGE PLAN VIEW C
KEY NUMBERS REFER TO KEY NUMBERS ON PAGE 8

BILL OF MATERIAL		
LUMBER	LINEAR FEET	BOARD FEET
1" x 4"	87	29
2" x 4"	295	197
2" x 6"	126	126
NAILS	NO. REQD	POUNDS
6d (2")	96	1/2
10d (3")	380	5-3/4
20d (4")	32	1-1/4
STEEL STRAPPING, 1-1/4" - 267' REQD - 38-1/4 LBS		
SEAL FOR 1-1/4" STRAPPING - 24 REQD - 1-1/4 LBS		
STEEL STRAPPING, 2" - - - 183' REQD - - - 61 LBS		
SEAL FOR 2" STRAPPING - - - 48 REQD - - 9-3/4 LBS		
ANTI-CHAFING MATERIAL - - - AS REQD - - - - - NIL		
WIRE, .0800" DIAMETER - - 18' REQD - - - 1/2 LB		
STAPLES, 2" - - - - - 12 REQD - - - 1/4 LB		

LOAD AS SHOWN

ITEM	QUANTITY	WEIGHT (APPROX)
PrSM LPMC (EMPTY)	- - 12	- - - - - 16,236 LBS
DUNNAGE	- - - - -	- - - - - 822 LBS
TOTAL WEIGHT		- - - - - 17,058 LBS (APPROX)

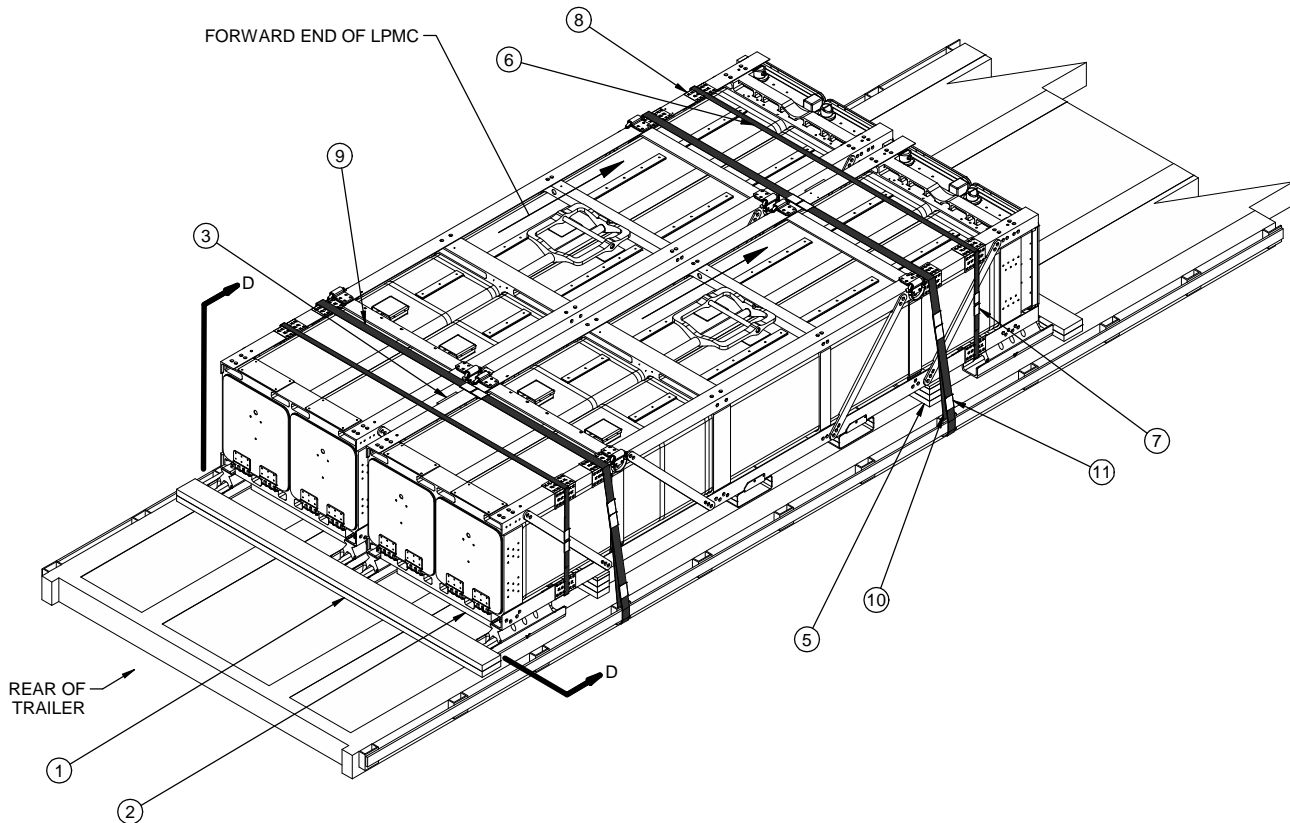

ISOMETRIC VIEW

KEY NUMBERS

SPECIAL NOTES:

1. A 2 UNIT LTL LOAD IS SHOWN ON A 8'-0" WIDE FLATBED TRAILER. OTHER WIDTH TRAILERS MAY BE USED.
2. IF CHAINS AND LOAD BINDERS ARE TO BE USED FOR LOAD SECUREMENT IN LIEU OF THE WEB STRAPPING, REFER TO THE PROCEDURES ON PAGES 6 AND 7 FOR GUIDANCE. IF WEB STRAPS ARE TO BE USED FOR LOAD SECUREMENT, REFER TO THE PROCEDURES ON PAGES 4 AND 5 FOR GUIDANCE.
3. THE DEPICTED LOAD CAN BE INCREASED OR REDUCED TO SUIT THE QUANTITY TO BE SHIPPED. SEE THE DETAILS ON PAGES 4, 6, 8, AND 11 FOR OTHER LOADING CONFIGURATIONS AND QUANTITIES.
4. ALL STRAPS AND SUPPORTS MUST BE INSTALLED NEAR THE STRONG POINTS OR VERTICALLY REINFORCED AREAS OF THE PODS AS SHOWN ABOVE.
5. SUPPORT "A" MAY BE PREASSEMBLED, IF DESIRED; TOENAIL TO THE TRAILER FLOOR W/4-10d NAILS ON EACH SIDE.
6. **CAUTION:** THE HOLD-DOWN STRAPS MUST BE INSTALLED WITH CARE SO AS NOT TO HAVE EDGE-TO-EDGE CONTACT WITH THE LOAD BUNDLING STRAPS.

- ① HEADER, 2" X 6" X 7'-6" (DOUBLED) (2 REQD). NAIL THE FIRST PIECE TO THE TRAILER FLOOR W/6-10d NAILS. LAMINATE THE SECOND PIECE TO THE FIRST W/6-20d NAILS.
- ② SIDE BLOCKING, 2" X 6" BY CUT-TO-FIT BETWEEN POD SKIDS (DOUBLED) (4 REQD). PREPOSITION AS SHOWN IN THE "PREPOSITIONED DUNNAGE PLAN VIEW" ON PAGES 5 OR 7. NAIL THE FIRST PIECE TO THE TRAILER FLOOR W/3-10d NAILS. NAIL THE SECOND PIECE TO THE FIRST IN A SIMILAR MANNER.
- ③ ANTI-CHAFING, 2" X 4" X 31" (2 REQD). POSITION AS SHOWN AND WIRE TIE TO A VERTICAL FRAME MEMBER OF ONE POD AT TWO LOCATIONS.
- ④ TIE WIRE, .0800" DIA, 18" LONG (4 REQD). INSTALL THE WIRE TO FORM A COMPLETE LOOP AROUND THE ANTI-CHAFING PIECE AND A VERTICAL FRAME MEMBER OF A POD. BRING ENDS TOGETHER AND TWIST TAUT.
- ⑤ SUPPORT A (2 REQD). PREPOSITION AS SHOWN IN THE "PREPOSITIONED DUNNAGE PLAN VIEW" ON PAGES 5 OR 7. NAIL THE FIRST 2" X 4" TO THE TRAILER FLOOR W/6-10d NAILS. NAIL THE REMAINING PIECES ACCORDING TO DETAIL ON PAGE 12. SEE SPECIAL NOTE 5 AT LEFT.
- ⑥ BUNDLING STRAP, 1-1/4" X .035" OR .031" X 19'-6" LONG STEEL STRAPPING (2 REQD). INSTALL TO ENCIRLCE LATERALLY ADJACENT PODS AS SHOWN.
- ⑦ SEAL FOR 1-1/4" STEEL STRAPPING (4 REQD, 2 PER STRAP). DOUBLE CRIMP EACH SEAL. SEE GENERAL NOTE "N" ON PAGE 2.
- ⑧ ANTI-CHAFING NEUTRAL BARRIER MATERIAL (AS REQD). POSITION UNDER ALL STRAPS AT POINTS OF CONTACT WITH THE POD.
- ⑨ HOLD-DOWN STRAP, 2" X .050" OR .044" X 22'-0" LONG STEEL STRAPPING (2 REQD). INSTALL EACH STRAP FROM TWO 11'-0" LONG PIECES. STAPLE TO THE STRAPPING BOARD W/2 STAPLES. DO NOT OVERTENSION THE HOLD-DOWN STRAP.
- ⑩ PAD, 2" X .050" OR .044" X 18" LONG STEEL STRAPPING (4 REQD). POSITION BETWEEN THE HOLD-DOWN STRAP AND THE TRAILER STAKE POCKET AND SEAL TO THE HOLD-DOWN STRAP. SEE "DETAIL A" ON PAGE 13. ALT: STAKE POCKET PROTECTOR (24 REQD). USE TWO UNDER EACH ANCHORING FACILITY WITH A HOLD-DOWN STRAP. SEE "DETAIL B" ON PAGE 13.
- ⑪ SEAL FOR 2" STEEL STRAPPING (16 REQD, 8 PER STRAP). DOUBLE CRIMP EACH SEAL, EXCEPT THOSE USED TO SECURE THE PADS. SEE GENERAL NOTE "N" ON PAGE 2.

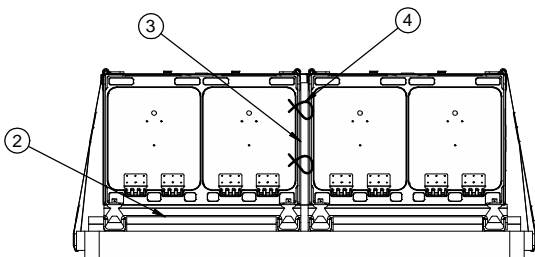

SECTION D-D

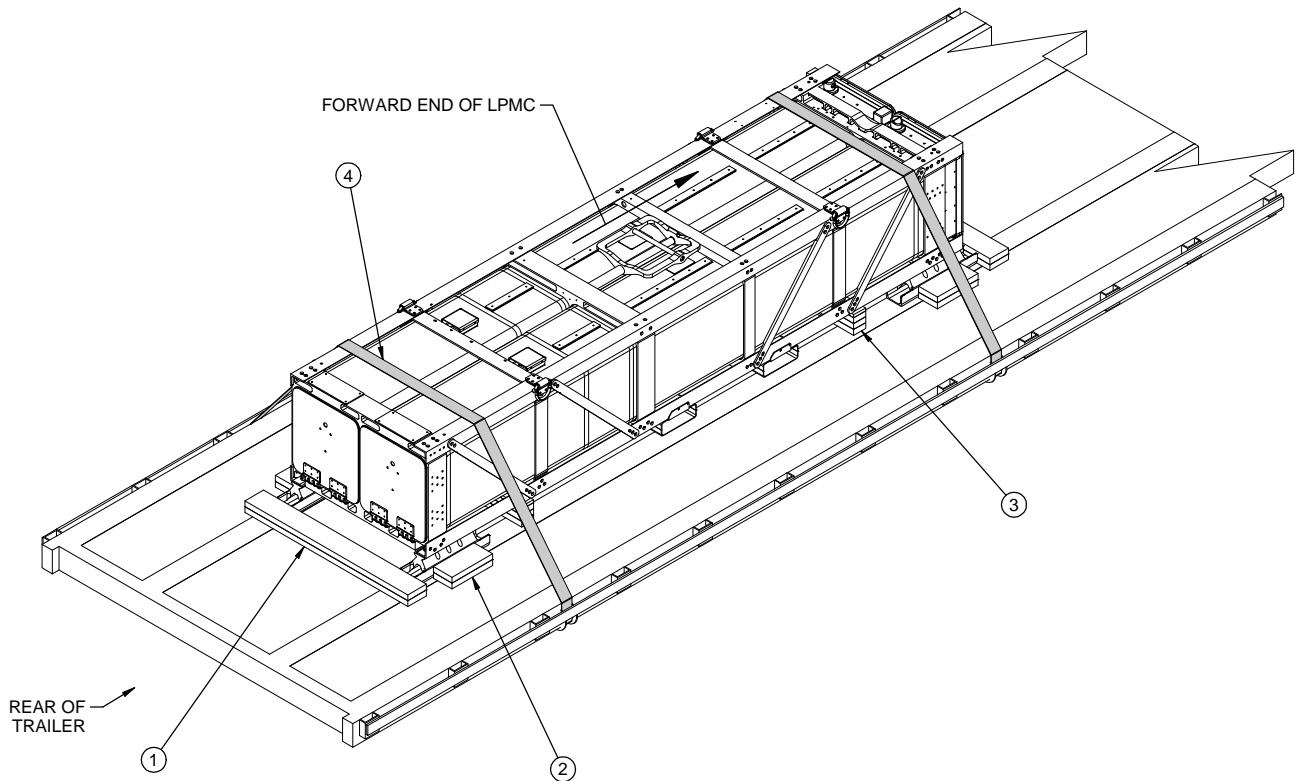

ISOMETRIC VIEW

KEY NUMBERS

SPECIAL NOTES:

1. A 1 UNIT LTL LOAD IS SHOWN ON A 8'-0" WIDE FLATBED TRAILER. OTHER WIDTH TRAILERS MAY BE USED.
2. IF CHAINS AND LOAD BINDERS ARE TO BE USED FOR LOAD SECUREMENT IN LIEU OF THE WEB STRAPPING, REFER TO THE PROCEDURES ON PAGES 6 AND 7 FOR GUIDANCE. IF STEEL STRAPS ARE TO BE USED FOR LOAD SECUREMENT, REFER TO THE PROCEDURES ON PAGES 8 AND 9 FOR GUIDANCE.
3. THE DEPICTED LOAD CAN BE INCREASED TO SUIT THE QUANTITY TO BE SHIPPED. SEE THE DETAILS ON PAGES 4, 6, 8, AND 10 FOR OTHER LOADING CONFIGURATIONS AND QUANTITIES.
4. ALL STRAPS AND SUPPORTS MUST BE INSTALLED NEAR THE STRONG POINTS OR VERTICALLY REINFORCED AREAS OF THE POD AS SHOWN ABOVE.

- ① HEADER, 2" X 6" X 48" (DOUBLED) (2 REQD). NAIL THE FIRST PIECE TO THE TRAILER FLOOR W/4-10d NAILS. LAMINATE THE SECOND PIECE TO THE FIRST W/4-20d NAILS.
- ② SIDE BLOCKING, 2" X 6" X 12" (DOUBLED) (4 REQD). POSITION AGAINST A POD SKID AND NAIL THE FIRST PIECE TO THE TRAILER FLOOR W/3-10d NAILS. LAMINATE THE SECOND PIECE TO THE FIRST IN A SIMILAR MANNER.
- ③ SUPPORT A, 42" LONG PIECES (2 REQD). PREPOSITION AS SHOWN IN THE "PREPOSITIONED DUNNAGE PLAN VIEW" ON PAGE 5 OR 7. NAIL THE FIRST 2" X 4" TO THE TRAILER FLOOR W/4-10d NAILS. NAIL THE REMAINING PIECES ACCORDING TO DETAIL ON PAGE 12, WITH 4 NAILS PER PIECE.
- ④ WEB STRAP ASSEMBLY (2 REQD). POSITION TO EXTEND FROM A WINCH ON ONE SIDE OF THE TRAILER, OVER THE CONTAINERS, TO AN ATTACHMENT POINT ON THE OPPOSITE SIDE. SEE THE "SPECIAL PROVISIONS FOR WEB STRAP TIEDOWN" ON PAGE 15.

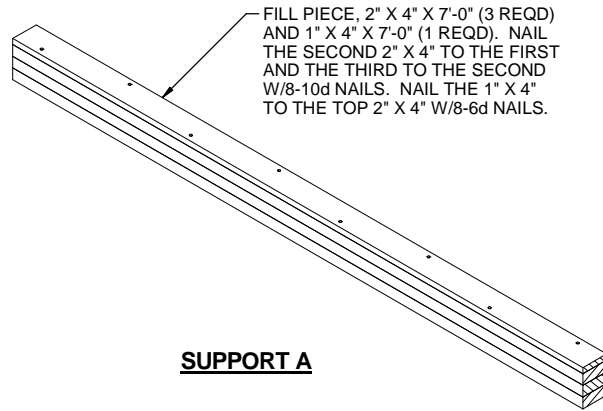

SUPPORT A

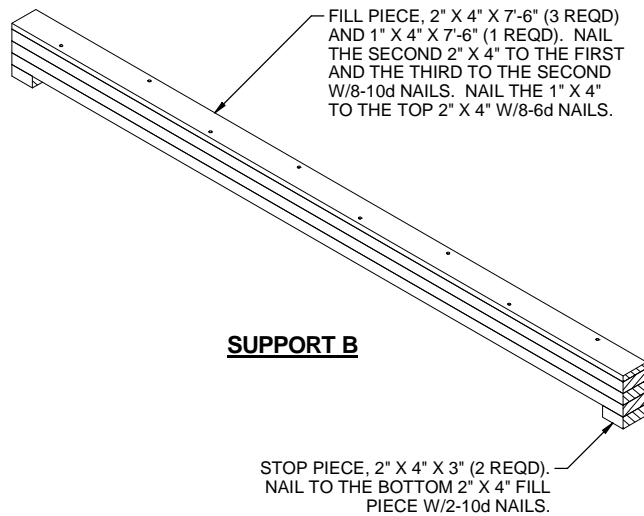

SUPPORT B

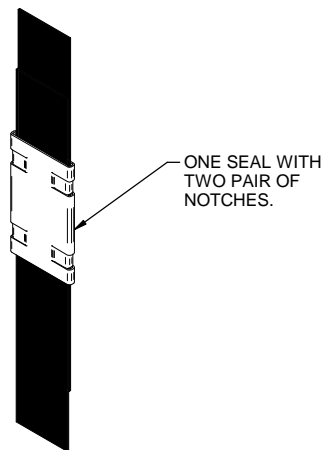

STRAP JOINT A

METHOD OF SECURING A STRAP JOINT WHEN USING A NOTCH-TYPE SEALER.

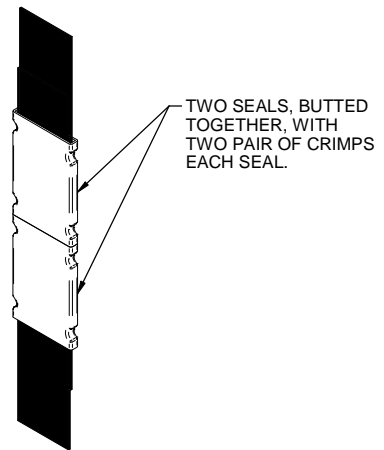

STRAP JOINT B

METHOD OF SECURING A STRAP JOINT WHEN USING A CRIMP-TYPE SEALER.

END-OVER-END LAP JOINT DETAILS

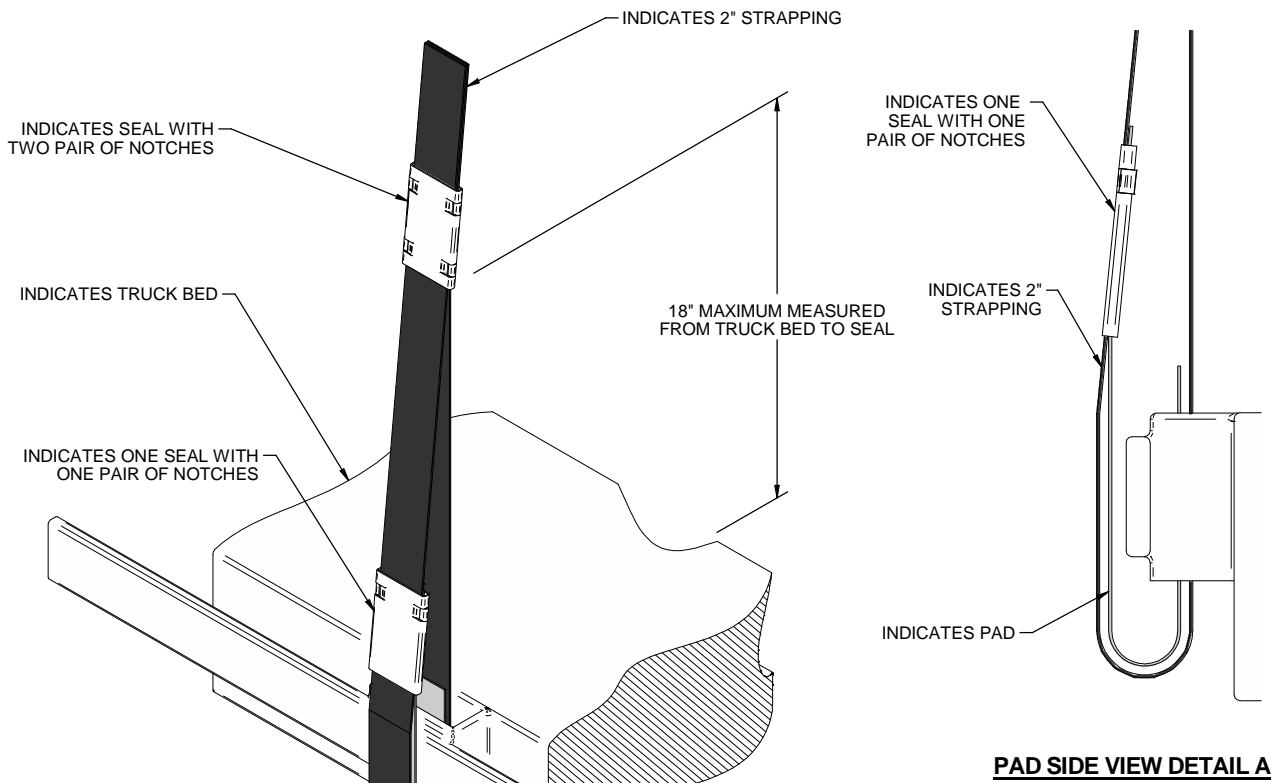

DETAIL A
 METHOD OF INSTALLING 2" STRAPPING AND PAD AT ANCHORING FACILITY.

PAD SIDE VIEW DETAIL A

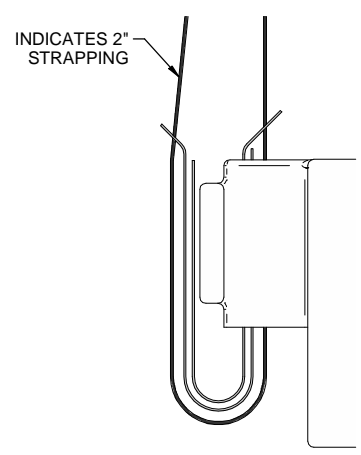

POCKET PROTECTOR SIDE VIEW DETAIL B

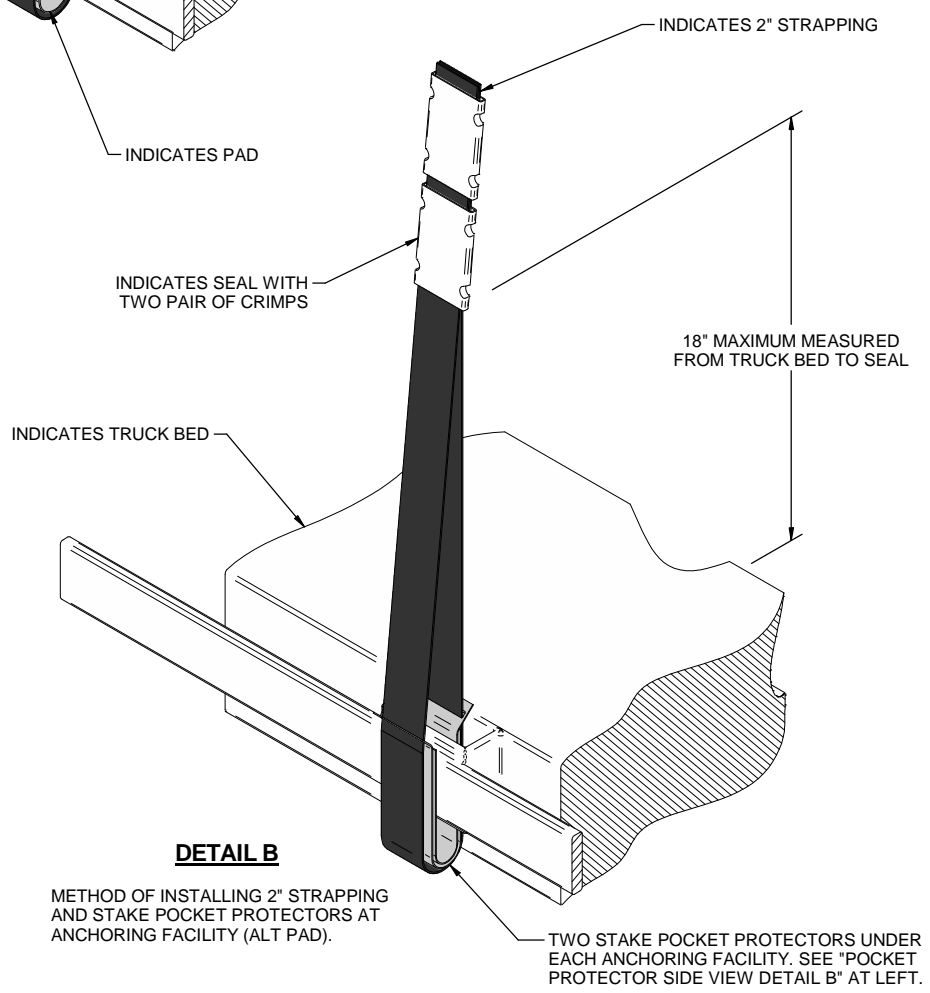

DETAIL B
 METHOD OF INSTALLING 2" STRAPPING AND STAKE POCKET PROTECTORS AT ANCHORING FACILITY (ALT PAD).

TWO STAKE POCKET PROTECTORS UNDER EACH ANCHORING FACILITY. SEE "POCKET PROTECTOR SIDE VIEW DETAIL B" AT LEFT.

STAKE POCKET STRAP DETAILS

SPECIAL PROVISIONS FOR WEB STRAP TIEDOWN

LADING MAY BE SECURED TO A FLATBED TRAILER BY WEB STRAP ASSEMBLIES IN LIEU OF STEEL STRAPPING OR CHAINS AND LOAD BINDERS, PROVIDED THE FOLLOWING CONDITIONS ARE MET.

1. ONLY WEB STRAPS OF GOOD QUALITY WILL BE USED. ALL WEB STRAPS AND ASSOCIATED HARDWARE SHALL CONFORM TO THE WEB SLING & TIEDOWN ASSOCIATION RECOMMENDED STANDARD SPECIFICATION FOR SYNTHETIC WEB TIEDOWNS, REVISED IN 2005.
2. ALL WEB STRAP TIEDOWN ASSEMBLIES SHALL BE PERMANENTLY LABELED WITHIN 18" OF ONE END TO SHOW:
 - A. NAME OR TRADEMARK OF MANUFACTURER
 - B. WORKING LOAD LIMIT (WLL)
3. WEB STRAP ASSEMBLY MINIMUM BREAKING STRENGTH WILL BE AT LEAST THREE TIMES THE WLL MARKED ON THE STRAP.
4. THE TOTAL MINIMUM BREAKING STRENGTH (MBS) OF THE STRAPS USED TO RESTRAIN AMMUNITION ITEMS WILL BE AT LEAST 1-1/2 TIMES THE TOTAL WEIGHT OF THE ITEMS, WITH A MINIMUM OF TWO STRAPS POSITIONED OVER EACH LOAD UNIT ON A TRAILER. THE CARRIER SHALL PROVIDE WRITTEN PROOF OF THE MBS OF THE STRAPS TO THE SHIPPING ACTIVITY IF REQUESTED.
5. CARRIERS MUST COMPLY WITH ALL FEDERAL, STATE, AND LOCAL REGULATIONS APPLICABLE TO CARGO RESTRAINT USING WEB STRAPS.
6. WHEN USING STRAPS AND WINCHES FOR CARGO RESTRAINT, THE STRAPS WILL BE TENSIONED UNTIL TIGHT WITHOUT CAUSING DAMAGE TO THE CARGO. ONLY WINCH BARS WILL BE USED FOR OPERATING THE STRAP WINCHES.
7. BEFORE AND DURING INSTALLATION, THE WEB STRAP ASSEMBLIES SHALL BE INSPECTED FOR DEFECTS. STRAPS HAVING ANY OF THE FOLLOWING DEFECTS WILL NOT BE USED FOR THE RESTRAINT OF ANY AMMUNITION LOAD, WITH THE EXCEPTION OF ONE WITH FRAYED ENDS. A STRAP HAVING FRAYED ENDS CAN BE USED IF THE FRAYED END IS TRIMMED AND MELTED WITH HEAT OR FLAME UNTIL ALL STRANDS ARE SEIZED.

(CONTINUED AT RIGHT)

(SPECIAL PROVISIONS FOR WEB STRAP TIEDOWN CONTINUED)

- A. STRAP ASSEMBLY HARDWARE: SHALL BE INSPECTED FOR BENT HOOKS, GOUGES, CORROSION, SIGNS OF REPAIR, BENT RATCHETS OR WINCHES, WEAR, OR ANY OTHER NOTICEABLE DEFECTS.
 - B. STRAP WEBBING: SHALL BE INSPECTED FOR KNOTS, EXCESSIVE ABRASIVE WEAR, TEARS, PUNCTURES, CUTS, ACID OR CAUSTIC BURNS, BROKEN STITCHES, FRAYED ENDS, OIL OR GREASE SPOTS EXCEEDING 6 SQUARE INCHES, BLEACHING OF COLOR, INCREASED STIFFNESS, SPLICES, VISIBLE WEAR INDICATOR THREADS, OR ANY OTHER NOTICEABLE DEFECTS.
8. RATCHET HANDLES MUST BE IN THE LOCKED POSITION AND/OR WINCH LOCKING DEVICES MUST BE FULLY SEATED IN THE TEETH OF THE WINCH.
 9. IF THE WINCHES BEING USED ARE THE REMOVABLE TYPE HAVING BOLTS FOR ATTACHMENT TO THE TRAILER, CARE MUST BE EXERCISED WHEN ATTACHING THE WINCHES TO THE TRAILER. IF EXCESSIVE FORCE IS EXERTED ON THE BOLT DURING TENSIONING, DEFORMATION OF THE WINCH BRACKET MAY OCCUR, AND SUBSEQUENTLY CAUSE FAILURE OF THE WINCH BRACKET DURING TRANSPORT. WINCHES MUST BE FASTENED TO THE TRAILER WITH A MINIMUM OF TWO BOLTS.
 10. DRIVERS MUST BE INSTRUCTED TO PERIODICALLY CHECK THE TIGHTNESS OF THE WEB STRAP ASSEMBLIES AND RETIGHTEN, IF NECESSARY.
 11. IF PROVIDED ON OR WITH THE WEB STRAP ASSEMBLIES, SCUFF SLEEVES/WEB PROTECTORS WILL BE USED WHEREVER THE STRAP PASSES OVER A SHARP CORNER OR IRREGULAR SURFACE. IF NOT PROVIDED, ANTI-CHAFING MATERIAL OF A SUITABLE THICKNESS WILL BE USED TO ENSURE THAT THE STRAP WEBBING IS NOT DAMAGED DURING TRANSPORT OF THE LOAD.
 12. THE HARDWARE FITTING OF THE TIEDOWN ASSEMBLIES MUST BE ATTACHED TO THE TRAILER IN SUCH A MANNER THAT THEY WILL REMAIN IN PLACE IF SLACK DEVELOPS IN THE STRAP DURING TRANSPORT.

SPECIAL PROVISIONS FOR CHAIN TIEDOWN

LADING MAY BE SECURED TO THE FLATBED TRAILER BY CARRIER-OWNED CHAINS AND LOAD BINDERS IN LIEU OF SPECIFIED STRAPPING, PROVIDED THE FOLLOWING CONDITIONS ARE MET AND THE PROCEDURES CONTAINED ON PAGES 6 AND 7 ARE FOLLOWED.

1. ONLY CHAINS AND LOAD BINDERS OF GOOD QUALITY WILL BE USED. ALL CHAINS AND LOAD BINDERS SHALL CONFORM TO THE NATIONAL ASSOCIATION OF CHAIN MANUFACTURER'S WELDED CHAIN SPECIFICATION ADOPTED APRIL 2010.
2. ALL CHAINS SHALL BE MARKED AS PRESCRIBED BY THE NATIONAL ASSOCIATION OF CHAIN MANUFACTURER'S WELDED CHAIN SPECIFICATION ADOPTED APRIL 2010. AT LEAST ONE LINK IN EVERY 36 LINKS SHALL CARRY THE MANUFACTURER'S PERMANENT AND DISTINCTIVE MARK IDENTIFYING THE GRADE OF CHAIN. CHAINS NOT MARKED IN THIS MANNER SHALL NOT BE USED. IN ADDITION TO THE GRADE MARKING, THE CHAIN MAY ALSO CARRY LETTER MARKINGS OR SYMBOLS IDENTIFYING THE CHAIN MANUFACTURER. THE PRESENCE OF THE MANUFACTURER'S IDENTIFICATION MARKING IS NOT MANDATORY.
3. BEFORE AND DURING INSTALLATION, THE CHAINS AND LOAD BINDERS SHALL BE INSPECTED FOR BENT HOOKS, STRETCH, GOUGES, BENT LINKS, WEAR, OR ANY OTHER NOTICEABLE DEFECTS. ANY DEFICIENCY SHALL BE CAUSE FOR REJECTION OF A CHAIN OR LOAD BINDER. CHAINS MUST NOT BE TWISTED DURING INSTALLATION. **CAUTION:** EXTREME CARE MUST BE EXERCISED WHEN TENSIONING CHAINS TO PREVENT DAMAGE OR PERMANENT DEFORMATION TO THE LADING.
4. CHAIN SIZES AND GRADES APPROVED FOR USE WITH FLATBED TRAILER LOADS ARE AS FOLLOWS:
 - A. 3/8", GRADE 43 HIGH TEST CHAIN
 - B. 5/16", GRADE 70 TRANSPORT CHAIN
 - C. 3/8", GRADE 70 TRANSPORT CHAIN
 - D. 5/16", GRADE 80 ALLOY STEEL CHAIN
 - E. 3/8", GRADE 80 ALLOY STEEL CHAIN

(CONTINUED AT RIGHT)

(SPECIAL PROVISIONS FOR CHAIN TIEDOWN CONTINUED)

5. THE GRABHOOKS ON THE ENDS OF THE CHAIN MAY BE OF THE FOLLOWING TYPES WITH GRADE MARKINGS AS INDICATED.
 - A. CLEVIS GRABHOOKS, 3/8" SIZE, DO NOT REQUIRE GRADE MARKING. ALLOY GRABHOOKS, 5/16" SIZE, SHALL CARRY THE MANUFACTURER'S GRADE MARK OF 7, 70, OR 700. THE HOOKS SHALL BE USED ON THE APPROPRIATE SIZE CHAIN.
 - B. CLOSED EYE GRABHOOKS, 3/8" AND 5/16" SIZE, MAY BE USED ON THE APPROPRIATE SIZE CHAIN IF THEY ARE A PART OF A CHAIN ASSEMBLY WHICH WAS PROVIDED BY A CHAIN MANUFACTURER, AND THE CHAIN ASSEMBLY CARRIES THE CORRECT GRADE IDENTIFICATION MARKING AS PREVIOUSLY STATED. CLOSED EYE GRABHOOKS THAT FORM A PART OF THE CHAIN ASSEMBLY ARE EXEMPT FROM GRADE MARKINGS.
6. CONNECTING LINKS USED FOR CHAIN REPAIR MUST BE CORRECTLY MARKED AND BE EQUAL TO OR GREATER IN STRENGTH THAN THE CHAIN THEY ARE REPAIRING. CHAINS WITH UNMARKED CONNECTING LINKS SHALL NOT BE USED.
7. CHAIN AND FITTING OF A HIGHER GRADE MAY BE SUBSTITUTED FOR THE GRADES SPECIFIED IN NOTE 4.
8. LOAD BINDERS SHALL BE 5/16" TO 3/8" SIZE AND HAVE A MINIMUM BREAKING STRENGTH OF 16,200 POUNDS (WORKING LOAD LIMIT OF 5,400 POUNDS). OVERCENTER TYPE LOAD BINDERS SHALL BE SAFETY WIRED TO PREVENT ACCIDENTAL OPENING DURING TRANSPORT. LOAD BINDER SIZE SHALL BE COMPATIBLE WITH THE SIZE OF THE CHAIN BEING USED.

**PROVISIONS FOR THE USE OF FIRE HOSE IN LIEU OF
CHAIN BOARDS OR STRAPPING BOARDS**

FIRE HOSE THAT IS NO LONGER SUITABLE FOR USE IN FIRE FIGHTING APPLICATIONS CAN BE SUBSTITUTED FOR THE DOUBLED 2" BY 6" WOODEN CHAIN BOARDS OR SINGLE 2" BY 6" STRAPPING BOARDS, AS SPECIFIED HEREIN, PROVIDED THE FOLLOWING CONDITIONS ARE MET.

1. SUBSTITUTION AND APPLICATION GUIDANCE

- A. FIRE HOSE MAY BE USED WHEREVER A CHAIN OR STRAPPING BOARD CONTACTS A RIGID SURFACE OF THE LOAD PROVIDED GOUGING, SCRATCHING, CRACKING, BENDING, CRUSHING, OR OTHER VISIBLE DAMAGE DOES NOT OCCUR TO THE LOAD.
- B. ONE OR MORE SEGMENTS OF FIRE HOSE MAY BE USED TO REPLACE EACH CHAIN OR STRAPPING BOARD PROVIDING LOAD PROTECTION DURING TENSIONING OF TIEDOWNS AND LOAD SHIPMENT; I.E., A CHAIN BOARD NEED NOT BE REPLACED BY A SINGLE SEGMENT OF HOSE, MULTIPLE SEGMENTS MAY BE USED INSTEAD, AS LONG AS THEY ARE SECURELY FASTENED TO THE TIEDOWN. REGARDLESS OF THE NUMBER OF SEGMENTS USED, THE HOSE LENGTH WILL BE SUCH THAT IT EXTENDS AT LEAST 6" BEYOND THE EDGE OF THE LOAD.

2. ACCEPTABLE FIRE HOSE

- A. FIRE HOSE TO BE USED WILL BE A RUBBER LINED SINGLE OR DOUBLE JACKETED TYPE; I.E., IT MUST HAVE A RUBBER LINING INSIDE A SINGLE OR DOUBLED FABRIC (COTTON, LINEN, ETC.) JACKET.
- B. THE COLLAPSED WIDTH OF THE HOSE MUST BE A MINIMUM OF 2-1/2".
- C. THE HOSE SEGMENTS USED MUST NOT CONTAIN DEFECTS THAT WILL ALLOW DIRECT CONTACT OF THE CHAIN OR LOAD BINDER WITH THE LOAD. THE HOSE THICKNESS MUST ALSO BE OF SUCH A THICKNESS THAT DENTING OR DAMAGE TO THE LOAD DOES NOT OCCUR DURING CHAIN OR STRAP TENSIONING.

3. SECUREMENT TO CHAINS OR STRAPS

- A. THE SEGMENTS OF HOSE USED UNDER EACH CHAIN OR STRAP WILL BE SECURED TO THE CHAIN OR STRAP WITH ONE FASTENER EVERY 12", WITH A MINIMUM OF TWO FASTENERS REQUIRED PER HOSE SEGMENT.
- B. FASTENERS CAN CONSIST OF PLASTIC ELECTRICAL TIES, .0800" DIA WIRE, OR TAPE. REGARDLESS OF THE TYPE OF FASTENING USED, IT MUST PROVIDE A POSITIVE MEANS OF SECUREMENT OF THE HOSE TO THE CHAIN OR STRAP AND MUST NOT DAMAGE THE SURFACE OF THE POD, OR ITEM IT CONTACTS.

