

# JAVELIN

## LOADING AND TIEDOWN IN/ON TACTICAL VEHICLES OF GUIDED MISSILES PACKED ONE PER PLASTIC CONTAINER, PALLETIZED AND UNPALLETIZED

### INDEX

<u>ITEM</u>	<u>PAGE(S)</u>
GENERAL NOTES AND MATERIAL SPECIFICATIONS - - - - -	2
LOADING AND TIEDOWN GUIDANCE - - - - -	3, 4
ITEMIZED INDEX - - - - -	4

### U.S. ARMY MATERIEL COMMAND DRAWING

APPROVED, U.S. ARMY AVIATION AND MISSILE COMMAND  	<b>CAUTION: VERIFY PRIOR TO USE AT WWW.DAC.ARMY.MIL THAT THIS IS THE MOST CURRENT VERSION OF THIS DOCUMENT. THIS IS PAGE 1 OF 26.</b>							
APPROVED BY ORDER OF COMMANDING GENERAL, U.S. ARMY MATERIEL COMMAND  	<b>DO NOT SCALE</b>			<b>MAY 2004</b>				
	ENGINEER OR TECHNICIAN	BASIC REV.	<b>MARK GRACE</b>					
	TRANSPORTATION ENGINEERING DIVISION							
VALIDATION ENGINEERING DIVISION		TESTED	CLASS	DIVISION	DRAWING	FILE		
ENGINEERING DIRECTORATE			<b>19</b>	<b>48</b>	<b>8218</b>	<b>GM17JV2</b>		
U.S. ARMY DEFENSE AMMUNITION CENTER								

## GENERAL NOTES

- A. THIS DOCUMENT HAS BEEN PREPARED AND ISSUED IN ACCORDANCE WITH AR 740-1.
- B. THIS DRAWING COVERS PROCEDURES APPLICABLE TO THE TRANSPORT OF THE JAVELIN GUIDED MISSILE PACKED ONE PER CYLINDRICAL PLASTIC CONTAINER. SUBSEQUENT REFERENCE TO CONTAINER MEANS THE SHIPPING CONTAINER WITH CONTENTS. ALSO, SUBSEQUENT REFERENCE TO PALLET UNIT MEANS THE PALLETIZED UNIT OF SIX CONTAINERS WITH CONTENTS.
- C. FOR DETAIL OF THE CONTAINER, SEE MICOM DRAWING NO. 13303015 AND PAGE 5. FOR DETAIL OF THE PALLET UNIT, SEE AMC DRAWING 19-48-5270-GM20JV2.
- D. DEPICTED PROCEDURES APPLY TO TACTICAL VEHICLES HAVING FACTORY INSTALLED TIEDOWN ANCHORS AND/OR TACTICAL VEHICLES WHICH HAVE BEEN MODIFIED TO INCLUDE THE UNIVERSALLY APPLICABLE "TIEDOWN KIT" WHICH CONSISTS OF THE TIEDOWN FITTINGS OR ANCHOR DEVICES FOR INSTALLATION IN/ON CARGO BEDS, SIDEWALLS, AND/OR ENDWALLS, FOR USE WITH WEB STRAP TIEDOWN ASSEMBLIES. SEE PAGE 23 FOR GUIDANCE.
- E. ALL LOADS AND VEHICLES SHOWN HEREIN ARE TYPICAL AND ARE BASED ON TESTED PROCEDURES FOR OFF HIGHWAY TRANSPORT OF LOOSE AND/OR PALLETIZED ITEMS. COMBINATIONS OF PROCEDURES MAY BE USED IN/ON ANY TACTICAL VEHICLE. HOWEVER, THE APPROVED METHODS SPECIFIED HEREIN MUST BE FOLLOWED AS CLOSELY AS POSSIBLE.
- F. **CAUTION:** REGARDLESS OF RATED CAPACITY OF A SPECIFIC TACTICAL TRAILER, THE ACTUAL LOAD CONFIGURATION FOR A MISSION MUST NOT EXCEED RATED CAPACITY OF THE TOWING TRACTOR TO BE USED.
- G. WEB STRAP TIEDOWN ASSEMBLIES MUST BE SECURELY HOOKED INTO ANCHORING DEVICES ON THE TRANSPORTING VEHICLE AND FIRMLY TENSIONED. FIRMLY TENSIONED MEANS, WHEN THE OPERATOR PULLS ON THE RATCHET HANDLE BY HAND, THE RATCHET WILL NOT ADVANCE ANOTHER NOTCH. NO TYPE OF MECHANICAL EXTENSION OR LEVER WILL BE USED. EXERCISE CARE DURING STRAP APPLICATION. AVOID TWISTS IN THE STRAP TO THE EXTENT POSSIBLE (IF TIME PERMITS) BUT ENSURE THERE ARE NO KNOTS IN THE STRAP. ON THE TAKE-UP SPOOL OF THE RATCHET, ENSURE STRAIGHT LAY OF THE STRAP WHEN TENSIONING. AFTER INITIAL WEBBING-TO-WEBBING CONTACT HAS BEEN MADE, BY ROTATING THE TAKE-UP SPOOL UNTIL NO METAL ON THE SPOOL IS SHOWING AND THE STRAP HAS MADE CONTACT WITH ITSELF, THE TENSIONED STRAP MUST FORM AT LEAST 1/2 BUT NOT MORE THAN 1-1/2 WRAPS OF STRAP ON THE TAKE-UP SPOOL OF THE TENSIONING RATCHET. AFTER TENSIONING IS COMPLETED, ENSURE THAT THE SPOOL LOCKING LATCH IS FULLY SEATED AT BOTH ENDS OF THE SPOOL IN MATCHING LOCKING NOTCHES. TIE BACK THE LOOSE END OF THE STRAP AFTER TENSIONING IS COMPLETED (LOOSE ENDS MAY BE FOLDED AND TAPED OR TIED TO THE TENSIONING STRAP IF TIME PERMITS). FOR ADDITIONAL GUIDANCE, SEE "RATCHET/RATCHETING DETAILS" ON PAGES 24 AND 25.
- H. ADJUSTABLE SCUFF SLEEVES PROVIDED ON WEB STRAP ASSEMBLIES WILL BE LOCATED TO PROVIDE A PAD WHERE STRAPS PASS OVER SHARP EDGES, OR RATCHETS AND HOOKS ON PREVIOUSLY INSTALLED WEB STRAP TIEDOWN ASSEMBLIES. METAL PARTS OF A STRAP ASSEMBLY SHOULD BE LOCATED SO AS TO AVOID CONTACT WITH THE CARGO. IF CONTACT CANNOT BE AVOIDED, A SUITABLE ANTI-CHAFING MATERIAL, AS LISTED UNDER THE MATERIAL SPECIFICATIONS BELOW, MUST BE POSITIONED BETWEEN THE METAL PARTS OF A STRAP ASSEMBLY AND THE CARGO AND IF NECESSARY, TAPED OR TIED IN POSITION.

(CONTINUED AT RIGHT)

## MATERIAL SPECIFICATIONS

STRAP - - - - - : WEBBING, UNIVERSAL TIEDOWN,  
NSN 5340-00-980-9277, PN10900880,  
OR NSN 1670-00-725-1437, PN1376-013,  
OR NSN 5340-01-089-4997, PN11669588,  
OR NSN 5340-01-204-3009, PN9392419.

ANTI-CHAFING  
MATERIAL - - - - - : CANVAS, BURLAP, TAPE OR ANY  
OTHER SUITABLE MATERIAL.

## (GENERAL NOTES CONTINUED)

- J. IF THE SIDE RACKS FOR A SEMITRAILER ARE TO BE TRANSPORTED ON THE LOADED TRAILER, THEY WILL BE STACKED ON THE TRAILER AND SECURED WITH A SUFFICIENT QUANTITY OF WEB STRAP TIEDOWN ASSEMBLIES TO PREVENT LOSS DURING TRANSPORT. **NOTE:** IF DESIRED, THE SIDE RACKS FOR THE M871 AND M872 SEMITRAILERS MAY BE POSITIONED IN PLACE AFTER THE LOAD HAS BEEN SECURED. AFTER ALL SIDE PANELS AND REAR PANELS ARE IN POSITION, THE STAKES MUST BE SECURELY "PINNED" OR "WIRE-TIED" TO THE STAKE POCKETS TO PREVENT VERTICAL DISPLACEMENT DURING TRANSPORT. ALSO, THE SIDE PANELS MUST BE SECURED AT THE TOP WITH THE CROSS-CHAINS WHICH ARE PROVIDED WITH THE VEHICLE.
- K. PROCEDURES DEPICTED HEREIN ARE TYPICAL IN NATURE. ITEM LOCATION AND QUANTITIES OF THE DESIGNATED ITEM MAY BE VARIED TO SATISFY OPERATIONAL REQUIREMENTS, PROVIDING LOADING AND TIEDOWN PRINCIPLES SPECIFIED HEREIN ARE RETAINED.
- L. WHEN ONE WEB TIEDOWN STRAP ASSEMBLY IS NOT LONG ENOUGH TO SPAN THE DISTANCE DEPICTED, TWO ASSEMBLIES MAY BE HOOKED TOGETHER TO GAIN THE NECESSARY LENGTH.
- M. SOME TIEDOWN METHODS WITHIN THIS DRAWING SHOW TWO HOOKS TO BE CONNECTED TO ONE TIEDOWN EYE. THIS IS AUTHORIZED AS SPECIFIED HEREIN. WHEN TWO STRAPS ARE TO BE ATTACHED TO THE SAME TIEDOWN ANCHOR, ATTACH THE RATCHET END OF ONE STRAP AND THE NON-RATCHET END OF THE SECOND STRAP TO THE TIEDOWN ANCHOR PRIOR TO RATCHETING STRAPS TIGHT.
- N. STRAP RATCHETS SHOULD BE POSITIONED ON THE SAME SIDE OF THE LOAD, WHERE POSSIBLE, EXCEPT AS DELINEATED IN GENERAL NOTE "N" ABOVE.
- O. TIEDOWN PROCEDURES SHOWN WITHIN THIS DRAWING ALSO APPLY TO DROP SIDE VEHICLES HAVING TIEDOWN ANCHORS INSTALLED ON THE DROP SIDES. THE TAILGATE MUST ALWAYS BE IN THE CLOSED POSITION TO HELP STRENGTHEN THE DROP SIDES.
- P. DURING LONG HAULS, WHEN POSSIBLE, STRAPS SHOULD BE CHECKED DURING VEHICLE STOPS AND TIGHTENED, IF NECESSARY.
- Q. ONLY THE CARGO BODIES OR BEDS OF THE TACTICAL VEHICLES HAVE BEEN SHOWN HEREIN TO PREVENT DISTRACTION FROM THE DELINEATED LOADING AND TIEDOWN PROCEDURES, AND ARE SHOWN IN OUTLINE FORM WITH THE STRUCTURAL PORTIONS OMITTED AS NECESSARY TO IMPROVE THE CLARITY OF THE DEPICTED PROCEDURES.
- R. DUE TO VARIOUS REASONS, SUCH AS ROUGH TERRAIN DURING OFF HIGHWAY TRANSPORT, PANIC STOPS, METAL FLOORS ON VEHICLES AND NORMAL STRETCH OF WEB STRAPS, LOADED ITEMS MAY SLIDE SLIGHTLY LATERALLY AND/OR LONGITUDINALLY DURING TRANSPORT. THIS IS AN ACCEPTABLE CHARACTERISTIC AND IS NOT DETRIMENTAL TO LOAD SECUREMENT.
- S. IF THE TIEDOWN ANCHORS ON THE SIDE OF THE VEHICLE ARE TOO CLOSE TOGETHER, TOO FAR APART, OR ARE NOT IN A LOCATION THAT WILL ALLOW ADEQUATE HOLD DOWN OF LOAD WHEN WEB STRAPS ARE POSITIONED STRAIGHT OVER TOP, THE LOAD HOLD DOWN STRAPS MAY BE CROSSED OVER THE TOP OF THE LOAD AS SHOWN IN THE LOAD ON PAGE 9.
- T. ALL THE PALLETIZED LOADS SHOWN HEREIN ARE CONFIGURED AS ONE HIGH LOADS, WITH THE EXCEPTION OF THE LOADS ON PAGES 12, 15 AND 16. THESE LOADS DEPICT A METHOD FOR LOADING PALLET UNITS TWO HIGH ON A VEHICLE. THE TWO HIGH LOADING METHOD MAY BE ADAPTED FOR ANY OF THE LOADS SHOWN ON PAGES 7, AND 9 THROUGH 17, IF DESIRED, AS LONG AS THE MAXIMUM VEHICLE PAYLOAD AND LOAD HEIGHT ARE NOT EXCEEDED.
- U. CONVERSION TO METRIC EQUIVALENTS: DIMENSIONS WITHIN THIS DOCUMENT ARE EXPRESSED IN INCHES, AND WEIGHTS ARE EXPRESSED IN POUNDS. WHEN NECESSARY, THE METRIC EQUIVALENTS MAY BE COMPUTED ON THE BASIS OF ONE INCH EQUALS 25.4MM AND ONE POUND EQUALS 0.454 KG.
- V. FOR ADDITIONAL GUIDANCE SEE THE "LOADING, TIEDOWN, AND UNLOADING PROCEDURES" ON PAGES 3 AND 4, THE "SPECIAL NOTES" ON LOAD PAGES, AND THE "LOAD PLANNING GUIDANCE CHART" ON PAGE 26.

## LOADING AND TIEDOWN GUIDANCE

## (LOADING AND TIEDOWN GUIDANCE CONTINUED)

1. PRIOR TO LOADING AND/OR UNLOADING, SET BRAKES ON TACTICAL VEHICLE AND DROP TAILGATE. IF LOADING AND/OR UNLOADING TRUCK OR TRAILER, REMOVE SIDE RACKS FROM SEMITRAILERS, AND CANVAS COVERS AND BOWS FROM TRUCK OR TRAILER.
2. AFTER ALL LOADING PROCEDURES ARE COMPLETE, CHECK ALL WEB STRAP TIEDOWN ASSEMBLIES FOR MAXIMUM TIGHTNESS AND RATCHET TIGHTER, IF REQUIRED, PRIOR TO FOLDING UP AND SECURING THE LOOSE ENDS OF STRAP.
3. WHEN TWO STRAPS ARE TO BE ATTACHED TO THE SAME TIEDOWN ANCHOR, ATTACH THE RATCHET END OF ONE STRAP AND THE NON-RATCHET END OF THE SECOND STRAP TO THE TIEDOWN ANCHOR, PRIOR TO RATCHETING STRAPS TIGHT.
4. IF THE WEB STRAP TIEDOWN ASSEMBLIES BEING USED DO NOT HAVE SWIVEL HOOKS ON EACH END, ASSURE THAT ALL TWISTS ARE OUT OF STRAP PRIOR TO ATTACHING HOOKS TO TIEDOWN ANCHORS.
5. WHEN TRANSPORTING LESS THAN FULL LOADS ON TRUCKS AND/OR SEMITRAILERS, DO NOT POSITION PALLETES OR OTHER ITEMS OF LADING, WITHIN FIVE FEET OF AFT END, IF POSSIBLE, AS THIS IS THE ROUGHEST RIDING AREA IN/ON THE VEHICLE.
6. WHEN SECURING ITEMS IN THE 1-1/4 TON M998 HIGH MOBILITY MULTIPURPOSE WHEELED VEHICLE (HMMWV), USE THE FOLLOWING GUIDANCE.
  - A. THE CARGO AREA OF THE HMMWV IS EQUIPPED WITH EITHER EIGHT ORIGINAL OR MODIFIED TIEDOWN ANCHORS. ONLY THE SIX TIEDOWN ANCHORS LOCATED BETWEEN THE WHEEL WELLS MAY BE USED. HOWEVER, THESE ARE FIXED TIEDOWN ANCHORS DESIGNED FOR LONGITUDINAL FRONT-TO-REAR PULL AND ARE LIMITED TO THAT DIRECTION ONLY. NOTE THAT SIDE LOADING ON THE ORIGINAL OR MODIFIED TIEDOWN ANCHOR WILL CAUSE DAMAGE TO THE TIEDOWN ANCHOR AND/OR CAUSE THE TIEDOWN ANCHOR BOLT TO BECOME LOOSE. THE TWO TIEDOWN ANCHORS AT THE FORWARD END OF THE CARGO AREA ARE LOCATED UNDER THE FORWARD BULKHEAD AND CANNOT BE USED FOR TIEDOWN OF AMMUNITION AS THEY ARE NOT IN LONGITUDINAL ALIGNMENT WITH ANY OTHER TIEDOWN ANCHORS.
  - B. **CAUTION:** THE HMMWVS EQUIPPED WITH ORIGINAL TIEDOWN ANCHORS MUST NOT BE USED FOR RAIL TRANSPORT OF AMMUNITION. THE ORIGINAL TIEDOWN ANCHORS CAN BE IDENTIFIED BY THE HEX HEAD BOLT SECURING THE TIEDOWN ANCHOR TO THE FLOOR OF THE VEHICLE. THE ORIGINAL TIEDOWN ANCHOR SHOULD BE REPLACED WITH THE MODIFIED TIEDOWN ANCHORS AS INSTRUCTED IN PARAGRAPH C OR MODIFIED BY USING EYE BOLTS AS INSTRUCTED IN PARAGRAPH D.
  - C. THE HMMWVS EQUIPPED WITH MODIFIED TIEDOWN ANCHORS CAN BE IDENTIFIED BY THE PHILLIPS HEAD SCREW SECURING THE TIEDOWN ANCHOR TO THE FLOOR OF THE VEHICLE, IN LIEU OF A HEX HEAD BOLT. THE STATIC RATED WORKING LOAD OF THE MODIFIED TIEDOWN ANCHORING ASSEMBLY IS 2,500 POUNDS APPLIED LONGITUDINALLY ONLY. SIDE LOADING WILL AGAIN CAUSE DAMAGE TO THE ANCHOR AND/OR CAUSE THE ANCHOR SCREW TO BECOME LOOSE. THESE TIEDOWN ANCHORS MAY BE USED TO SECURE LOOSE AND/OR PALLETIZED AMMUNITION AND/OR OTHER ITEMS FOR TRANSPORT BY RAIL AND/OR SHIP. THE HOLD-DOWN WEB STRAPS MAY BE POSITIONED AT AN ANGLE OF 0° TO 90°. SINCE JANUARY 1990 ALL NEW PRODUCTION HMMWVS HAVE THE MODIFIED TIEDOWN ANCHOR FACTORY INSTALLED (ALL VEHICLES WITH SERIAL NO. 100,000 AND ABOVE). IF THE VEHICLE BEING USED IS NOT EQUIPPED WITH THE MODIFIED TIEDOWN ANCHOR IT IS THE RESPONSIBILITY OF THE USING UNIT TO ORDER THEM FROM GOVERNMENT SUPPLY (NSN 3990-01-314-8393, P/N 12342077). TECHNICAL MANUAL 9-2320-280-20 & P DELINEATES THIS NEWER MODIFIED TIEDOWN ANCHOR.
  - D. THE HMMWVS EQUIPPED WITH ORIGINAL TIEDOWN ANCHORS MAY ALSO BE MODIFIED BY USING EYE BOLTS IN LIEU OF THE ORIGINAL TIEDOWN ANCHORS. THESE INTERIM PROCEDURES MAY BE USED TEMPORARILY UNTIL THE MODIFIED TIEDOWN ANCHORS ARE ORDERED AND INSTALLED. REMOVE THE ORIGINAL TIEDOWN ANCHORS AND REPLACE WITH 1/2" SHOULDER EYE BOLTS, MS51937, SIZE 1/2", 13 UNC-2A, NSN 5306-00-050-0347. THE EYE BOLTS ARE TO BE TIGHTENED TO 75 FOOT-POUNDS. THE FINAL ORIENTATION OF THE EYE BOLT SHOULD HAVE THE DIAMETER OF THE EYE POSITIONED PARALLEL TO THE VEHICLE SIDEWALL. THESE TIEDOWN ANCHORS MAY BE USED TO SECURE LOOSE AND/OR PALLETIZED AMMUNITION AND/OR OTHER ITEMS FOR TRANSPORT BY RAIL AND/OR SHIP. THE HOLD-DOWN WEB STRAPS MAY BE POSITIONED AT AN ANGLE OF 0° TO 90°.
7. WHEN USING WEB STRAP TIEDOWN ASSEMBLIES THAT HAVE THE RATCHET AND NON-SWIVEL HOOK ON THE END OF THE STRAP, IT MAY NOT BE POSSIBLE TO PROPERLY OPERATE THE RATCHET IF THE SPACE BETWEEN THE LOAD AND THE VEHICLE SIDEWALL IS LESS THAN 12" AND THE STRAP IS POSITIONED AT A STEEP, NEAR VERTICAL ANGLE. IF THE RATCHET CANNOT BE PROPERLY OPERATED TO ATTAIN A TIGHT STRAP, USE ONE OR MORE OF THE FOLLOWING METHODS:
  - A. HOOK THE RATCHET ENDS OF TWO WEB STRAP TIEDOWN ASSEMBLIES TOGETHER. POSITION THE RATCHETS ON TOP OF THE PALLET UNITS, AND ATTACH THE NON-RATCHET HOOK END OF EACH STRAP TO A TIEDOWN ANCHOR ON EACH SIDE OF THE VEHICLE. MAKE SURE THERE IS ONE-HALF TO ONE-AND-ONE-HALF WRAPS OF STRAP ON ONE RATCHET, THEN TAKE UP EXCESS SLACK IN REMAINING RATCHET AND RATCHET TIGHT. THIS METHOD REQUIRES TWO WEB STRAP TIEDOWN ASSEMBLIES IN LIEU OF ONE STRAP AT EACH LOCATION A STRAP IS POSITIONED OVER THE TOP OF A LOAD.
  - B. IF A MAXIMUM LOAD IS NOT REQUIRED, THE PALLET UNITS CAN BE POSITIONED ONE WIDE, DOWN THE CENTER OF THE VEHICLE LENGTH, IN LIEU OF TWO WIDE. SEE THE LOAD ON PAGE 17 FOR GUIDANCE.
  - C. WHEN LOADING LATERALLY ADJACENT PALLET UNITS ACROSS THE WIDTH OF A VEHICLE HAVING SIDEWALLS, RATCHET OPERATING SPACE CAN BE GAINED BY ATTACHING NON-RATCHET ENDS OF STRAP TO TIEDOWN ANCHORS IN THE SIDEWALL AND THEN POSITIONING THE PALLET UNITS AS CLOSE TO THAT SIDEWALL AS POSSIBLE, LEAVING EXCESS SPACE BETWEEN THE LOAD AND THE SIDEWALL ON THE OPPOSITE SIDE OF THE VEHICLE WHERE THE RATCHET WILL BE LOCATED. THIS METHOD MAY ALSO BE USED IN VEHICLES HAVING TIEDOWN ANCHORS LOCATED ON THE FLOOR ALONG EACH SIDE OF THE VEHICLE. AFTER ATTACHING NON-RATCHET ENDS OF THE STRAP TO TIEDOWN ANCHORS IN THE FLOOR, POSITION THE PALLET UNITS AS CLOSE TO THE TIEDOWN ANCHORS ON THAT SIDE AS POSSIBLE.
  - D. A WEB STRAP ASSEMBLY, SUCH AS NSN 5340-01-204-3009, HAVING A SHORT LENGTH OF STRAP (AT LEAST 15") BETWEEN THE RATCHET AND THE HOOK END MAY BE USED. THIS TYPE OF WEB STRAP POSITIONS THE RATCHET ABOVE THE SIDEWALLS IN CARGO TRUCKS, AND ALLOWS FOR EASY OPERATION OF THE RATCHET HANDLE.
8. "LOOSE" CONTAINERS MAY BE POSITIONED ON TOP OF A PALLET UNIT AND SECURED WITH WEB STRAP TIEDOWN ASSEMBLIES, AS SHOWN ON PAGES 20 AND 21. "LOOSE" CONTAINERS MAY BE STACKED AND/OR BUNDLED ON TOP OF EACH OTHER AS SHOWN ON PAGES 18 THROUGH 21. STACKS MUST BE STABLE, SECURED TIGHTLY TO VEHICLE FLOOR, AND MUST NOT EXCEED THE LOAD HEIGHT OF THE VEHICLE BEING LOADED.
9. THE M871 SEMITRAILER IS EQUIPPED WITH THREE DIFFERENT TYPES OF TIEDOWN ANCHORS. TYPE I IS A REMOVABLE TIEDOWN ANCHOR THAT HAS ONE RING AND IS POSITIONED BY REACHING UNDER THE FLOOR OF THE TRAILER, INSERTING IT UP THRU THE HOLE AND ROTATING IT INTO POSITION (NOTE THAT THIS REMOVABLE TIEDOWN ANCHOR IS ALSO USED ON THE M872 SEMITRAILER). THERE ARE LOCATIONS FOR 10 OF THESE TIEDOWN ANCHORS ON EACH SIDE OF THE M871 SEMITRAILER. TYPE II IS A REMOVABLE TIEDOWN ANCHOR THAT HAS TWO RINGS AND IS POSITIONED BY DEPRESSING A SPRING LOCK LEVER AND INSERTING IT INTO A 1-3/4" DIAMETER HOLE FROM THE TOP. ASSURE THAT THE TIEDOWN ANCHOR IS FIRMLY SEATED AND ROTATED SO THE SPRING LOCK LEVER IS POINTING AWAY FROM THE DIRECTION OF THE PULL ON THE ATTACHED WEB STRAP ASSEMBLY. THERE ARE LOCATIONS FOR 10 OF THESE TIEDOWN ANCHORS ON EACH SIDE OF THE M871 SEMITRAILER. TYPE III IS A FIXED TIEDOWN ANCHOR THAT HAS ONE RING AND IS RECESSED INTO THE FLOOR. THERE ARE FIVE OF THESE TIEDOWN ANCHORS ON EACH SIDE OF THE M871 SEMITRAILER. NORMALLY TYPE II AND TYPE III TIEDOWN ANCHORS ARE USED TO SECURE THE LOAD. HOWEVER, TYPE I TIEDOWN ANCHORS MAY BE USED, IF AVAILABLE WHEN THERE IS AN INSUFFICIENT QUANTITY OF TYPE II TIEDOWN ANCHORS. SEE TIEDOWN ANCHOR DETAILS ON PAGE 23.

(CONTINUED ON PAGE 4)

(CONTINUED AT RIGHT)

10. THE M872 SEMITRAILER IS EQUIPPED WITH TWO DIFFERENT TYPES OF TIEDOWN ANCHORS. TYPE I IS A REMOVABLE TIEDOWN ANCHOR THAT HAS ONE RING AND IS POSITIONED BY REACHING UNDER THE FLOOR OF THE TRAILER, INSERTING IT UP THROUGH THE HOLE AND ROTATING IT INTO POSITION (NOTE THAT THIS REMOVABLE TIEDOWN ANCHOR MAY ALSO BE USED ON THE M871 SEMITRAILER). THERE ARE 28 LOCATIONS FOR THESE TIEDOWN ANCHORS ON EACH SIDE OF THE M872 SEMITRAILERS, THE QUANTITY AND LOCATION MAY VARY ON SOME M872 SEMITRAILERS. THE SECOND TYPE OF TIEDOWN ANCHOR IS THE "TEE-HOOK". THIS IS A REMOVABLE TIEDOWN ANCHOR EQUIPPED WITH ONE ELONGATED RING AND IS POSITIONED BY INSERTING IT INTO ONE OF THE ELONGATED SLOTTED HOLES WHICH ARE AT A 45° ANGLE TO THE SIDE OF THE TRAILER. THERE ARE FIVE LOCATIONS FOR THESE TIEDOWN ANCHORS ON EACH SIDE OF THE M872 SEMITRAILERS. THE QUANTITY AND LOCATION MAY VARY ON SOME M872 SEMITRAILERS. ASSURE THAT THE TIEDOWN ANCHOR IS FIRMLY SEATED AND ROTATED APPROXIMATELY 45° TO ENGAGED POSITION BEFORE ATTACHING THE WEB STRAP TIEDOWN ASSEMBLY. EITHER TYPE I OR TYPE II TIEDOWN ANCHORS MAY BE USED TO SECURE A LOAD. SEE "TIEDOWN ANCHOR DETAILS" ON PAGE 23.
11. WHEN A LOAD RESTRAINING WEB STRAP IS ATTACHED TO A VEHICLE TIEDOWN ANCHOR, THE WEB STRAP, THE STRAP HOOK, AND/OR RATCHET IF USING A STRAP HAVING THE RATCHETS AT THE VERY END OF THE STRAP, MUST FORM A STRAIGHT LINE IN THE DIRECTION OF PULL FROM THE VEHICLE TIEDOWN ANCHOR. THE STRAP HOOK, AND/OR END-OF-STRAP RATCHET MUST NOT BIND AGAINST THE VEHICLE FLOOR, AND/OR EDGE OF VEHICLE FLOOR IF VEHICLE TIEDOWN ANCHORS ARE LOCATED ALONG THE SIDE, SUCH AS ON THE M127 SEMITRAILER. IF THE STRAP HOOK, AND/OR END-OF-STRAP RATCHET, CONTACT THE FLOOR IN SUCH MANNER THAT THE DIRECTION OF THE PULL IS NOT A STRAIGHT LINE, AN INTERFACE, SUCH AS A CLEVIS, HAVING THE SAME STRENGTH AS THE VEHICLE TIEDOWN ANCHOR, MUST BE ATTACHED TO THE VEHICLE TIEDOWN ANCHOR. THE WEB STRAP WILL THEN BE ATTACHED TO THE INTERFACE. NOTE THAT CONTACT OF THE STRAP HOOK AND/OR END-OF-STRAP RATCHET WITH THE FLOOR OF THE VEHICLE IS PERMITTED AS LONG AS THE LOAD RESTRAINING STRAP, STRAP HOOK, AND/OR END-OF-STRAP RATCHET FORMS A STRAIGHT LINE IN THE DIRECTION OF PULL FROM THE VEHICLE TIEDOWN ANCHOR.

<u>ITEM</u>	<u>PAGES(S)</u>
GENERAL NOTES AND MATERIAL SPECIFICATIONS - - - - -	2
LOADING AND TIEDOWN GUIDANCE - - - - -	3, 4
JAVELIN CONTAINER AND PALLET UNIT DETAILS - - - - -	5
 <u>SECUREMENT OF PALLET UNITS</u>	
ONE PALLET UNIT IN A 3/4 TON M101 CARGO TRAILER - - -	6
ONE PALLET UNIT IN A 1-1/4 TON M1008 CUCV - - - - -	7
ONE PALLET UNIT IN A 1-1/2 TON M1102 HMT - - - - -	8
TWO PALLET UNITS IN A 2-1/2 TON M1078 CARGO TRUCK - -	9
THREE PALLET UNITS IN A 2-1/2 TON M35 CARGO TRUCK - -	10
THREE PALLET UNITS IN A 5 TON M1083 CARGO TRUCK - - -	11
10 PALLET UNITS IN A 5 TON M927A1 CARGO TRUCK - - - -	12
FOUR PALLET UNITS ON A 10 TON M977/M985 HEMTT - - - -	13
EIGHT PALLET UNITS ON A 16-1/2 TON M1077 PLS FLATRACK	14
12 PALLET UNITS ON AN M1 PLS FLATRACK - - - - -	15
14 PALLET UNITS ON A 22-1/2 TON M871 SEMITRAILER - - -	16
10 PALLET UNITS ON A 34 TON M872 SEMITRAILER - - - -	17
 <u>SECUREMENT OF LOOSE CONTAINERS</u>	
NINE LOOSE CONTAINERS IN A 1-1/4 TON M998 HMMWV - - -	18
15 LOOSE CONTAINERS IN A 1-1/4 TON M1008 CUCV - - - -	19
15 LOOSE CONTAINERS AND ONE PALLET UNIT IN A 5 TON M1083 CARGO TRUCK - - - - -	20
23 LOOSE CONTAINERS AND TWO PALLET UNITS ON AN M1 PLS FLATRACK - - - - -	21
ALTERNATIVE METHOD FOR SHIPMENT OF LOOSE CONTAINERS -	22
 <u>DETAILS</u>	
TIEDOWN ANCHOR DETAILS - - - - -	23
RATCHET/RATCHETING DETAILS - - - - -	24, 25
LOAD PLANNING GUIDANCE CHART - - - - -	26
 NOTE: THE TACTICAL VEHICLES LISTED IN THE INDEX ABOVE AND SHOWN WITHIN THIS DRAWING WERE SELECTED AS TYPICAL ONLY. OTHER TYPES OF VEHICLES MAY BE USED IN LIEU OF THOSE SHOWN AS LONG AS THEY COMPLY WITH GENERAL NOTE "D" ON PAGE 2.	

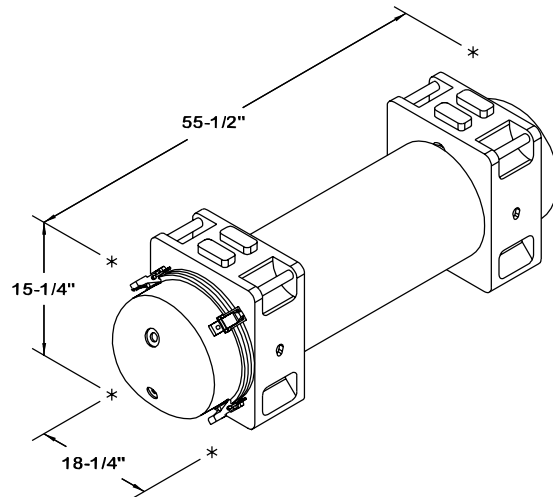

**CONTAINER DATA**

GROSS WEIGHT - - - - - 96 LBS (APPROX)  
 CUBE - - - - - 8.90 CUBIC FEET (APPROX)

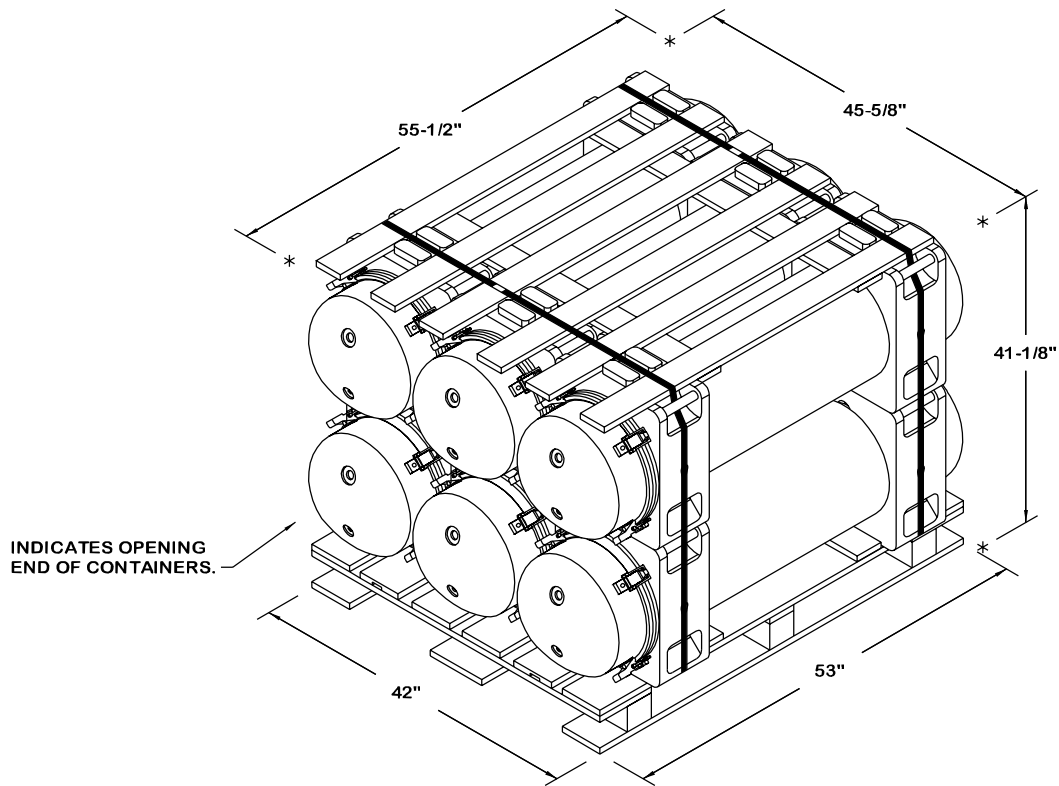

**PALLET UNIT**

GROSS WEIGHT - - - - - 695 LBS (APPROX)  
 CUBE - - - - - 60.30 CUBIC FEET (APPROX)

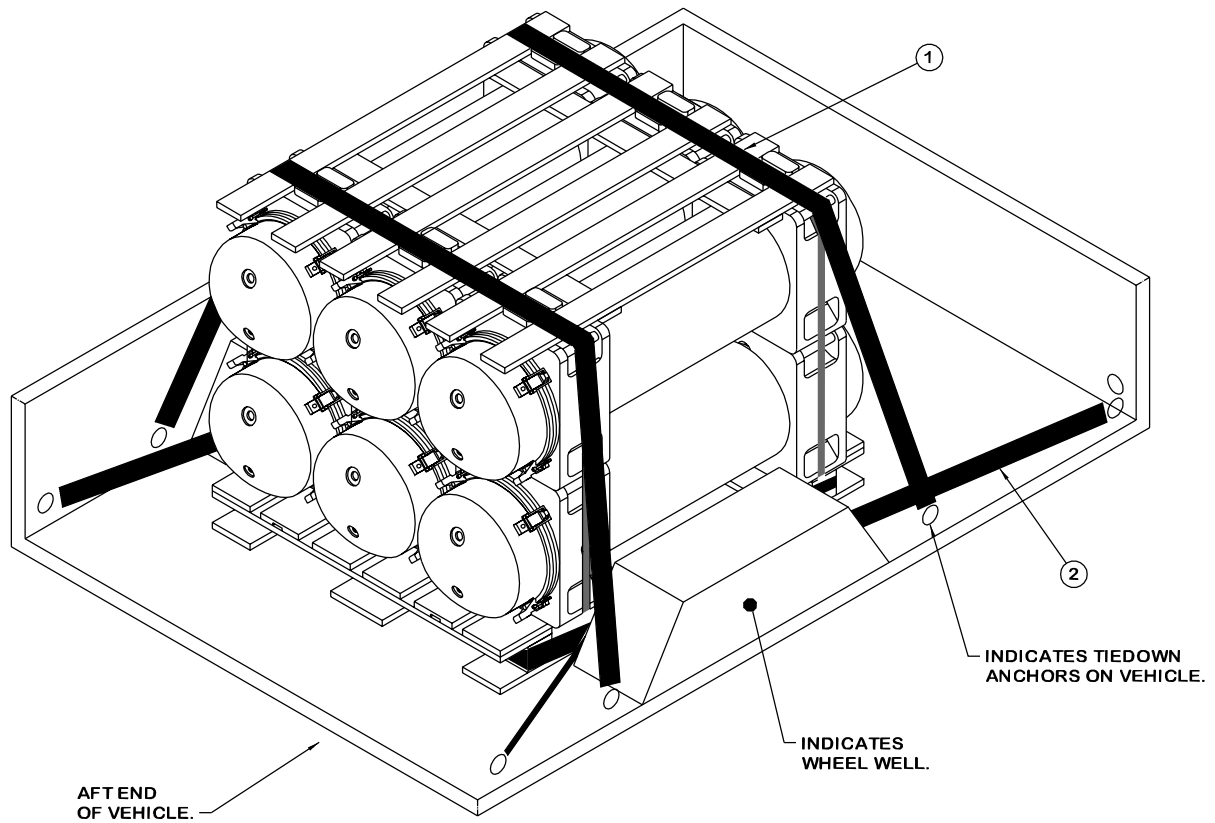

**ISOMETRIC VIEW**

**SPECIAL NOTES:**

1. A TYPICAL LOAD OF ONE PALLET UNIT IS SHOWN IN A 3/4 TON M101 CARGO TRAILER HAVING INSIDE DIMENSIONS OF 96" LONG BY 66" WIDE.
2. CENTER THE PALLET UNIT LONGITUDINALLY BETWEEN THE TWO TIEDOWN ANCHORS LOCATED ALONG ONE SIDE OF THE VEHICLE TO WHICH WEB STRAPS MARKED ① WILL BE ATTACHED. ALSO CENTER THE UNIT LATERALLY ACROSS THE VEHICLE WIDTH.
3. A TOTAL OF FOUR WEB STRAP TIEDOWN ASSEMBLIES ARE REQUIRED FOR THE LOAD SHOWN.

**KEY NUMBERS**

- ① WEB STRAP TIEDOWN ASSEMBLY (2 REQD). INSTALL EACH STRAP TO EXTEND FROM A TIEDOWN ANCHOR ON SIDE OF VEHICLE, OVER TOP OF PALLET UNIT, TO A TIEDOWN ANCHOR ON THE OPPOSITE SIDE OF THE VEHICLE.
- ② WEB STRAP TIEDOWN ASSEMBLY (2 REQD). INSTALL EACH STRAP TO EXTEND FROM A TIEDOWN ANCHOR ON ONE SIDE OF VEHICLE, AROUND PALLET AS SHOWN, TO A TIEDOWN ANCHOR ON THE OPPOSITE SIDE OF THE VEHICLE.

**LOAD AS SHOWN**

<u>ITEM</u>	<u>QUANTITY</u>	<u>WEIGHT (APPROX)</u>
PALLET UNIT	1	695 LBS

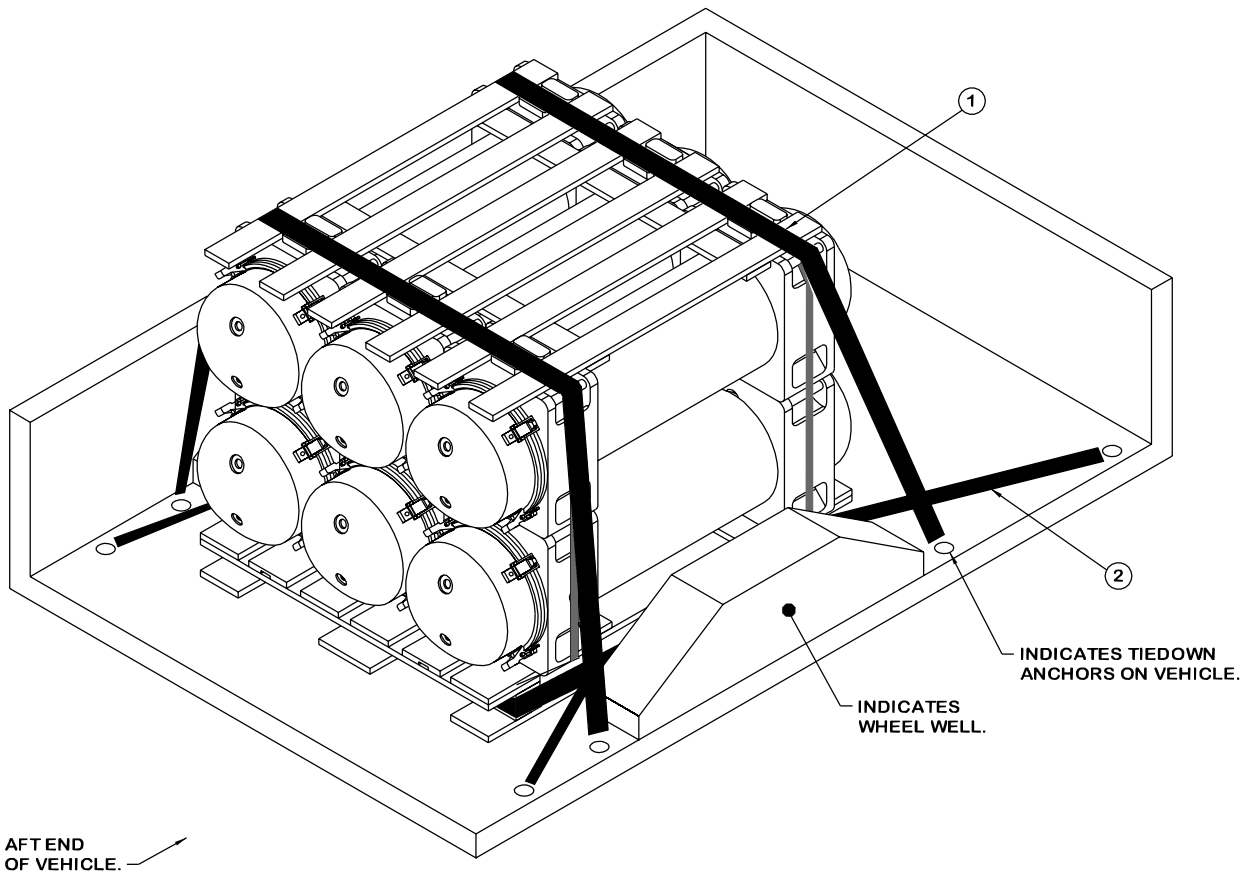

**ISOMETRIC VIEW**

**SPECIAL NOTES:**

1. A TYPICAL LOAD OF ONE PALLET UNIT IS SHOWN IN A 1-1/4 TON M1008 COMMERCIAL UTILITY CARGO VEHICLE (CUCV) HAVING INSIDE DIMENSIONS OF 98" LONG BY 65" WIDE.
2. PALLET UNITS MAY BE LOADED TWO UNITS HIGH, AS LONG AS THE CAPACITY OF THE VEHICLE IS NOT EXCEEDED. SEE THE LOADS ON PAGES 12, 15, AND 16 FOR DETAILS.
3. CENTER THE PALLET UNIT LONGITUDINALLY BETWEEN THE TWO TIEDOWN ANCHORS LOCATED ALONG ONE SIDE OF THE VEHICLE TO WHICH WEB STRAPS MARKED ① WILL BE ATTACHED. ALSO CENTER THE UNIT LATERALLY ACROSS THE VEHICLE WIDTH.
4. A TOTAL OF FOUR WEB STRAP TIEDOWN ASSEMBLIES ARE REQUIRED FOR THE LOAD SHOWN.

**KEY NUMBERS**

- ① WEB STRAP TIEDOWN ASSEMBLY (2 REQD). INSTALL EACH STRAP TO EXTEND FROM A TIEDOWN ANCHOR ON SIDE OF VEHICLE, OVER TOP OF PALLET UNIT, TO A TIEDOWN ANCHOR ON THE OPPOSITE SIDE OF THE VEHICLE.
- ② WEB STRAP TIEDOWN ASSEMBLY (2 REQD). INSTALL EACH STRAP TO EXTEND FROM A TIEDOWN ANCHOR ON ONE SIDE OF VEHICLE, AROUND PALLET AS SHOWN, TO A TIEDOWN ANCHOR ON THE OPPOSITE SIDE OF THE VEHICLE.

**LOAD AS SHOWN**

<u>ITEM</u>	<u>QUANTITY</u>	<u>WEIGHT (APPROX)</u>
PALLET UNIT	1	695 LBS

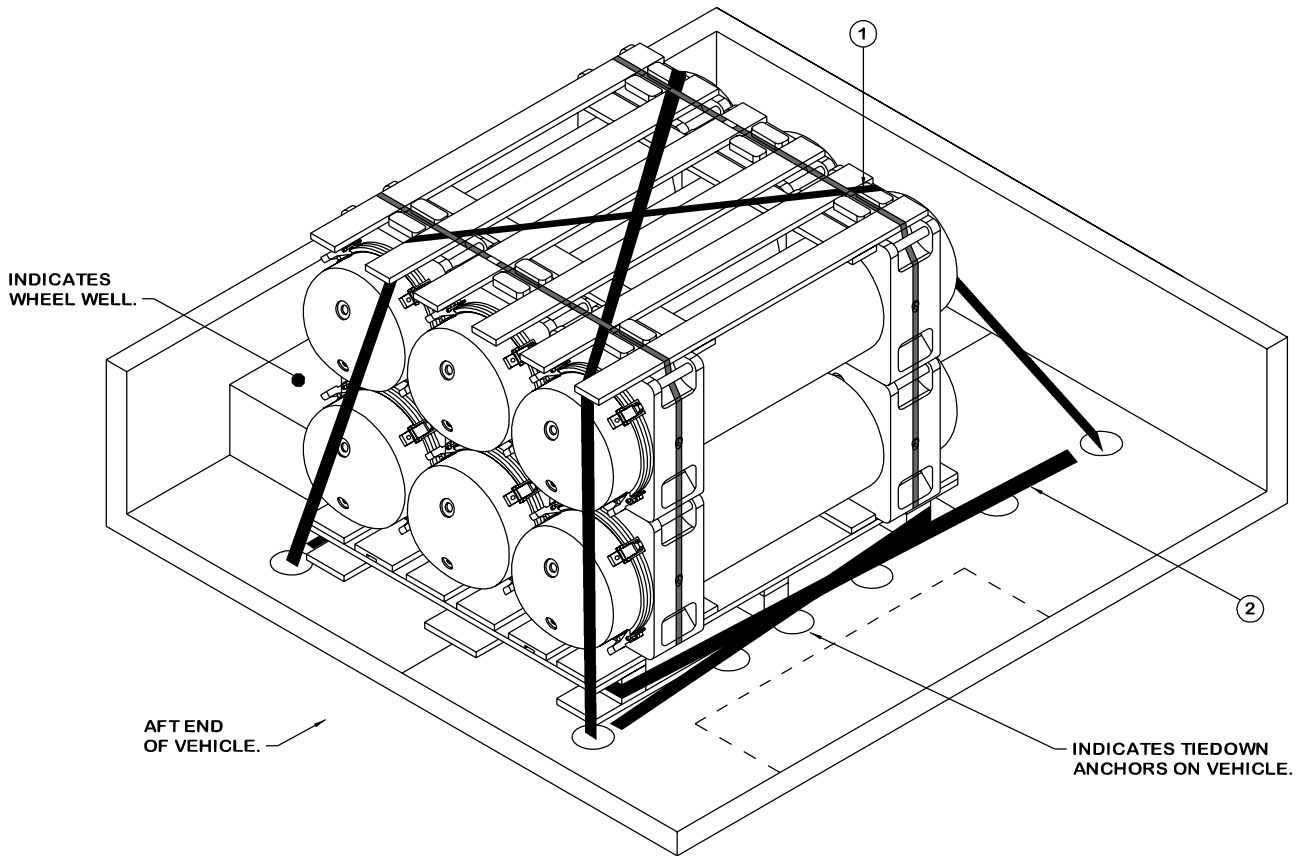

**ISOMETRIC VIEW**

**SPECIAL NOTES:**

1. A TYPICAL LOAD OF ONE PALLET UNIT IS SHOWN IN A 1-1/2 TON M1102 HIGH MOBILITY TRAILER (HMT) HAVING INSIDE DIMENSIONS OF 86" LONG BY 80-1/4" WIDE.
2. CENTER THE PALLET UNIT LONGITUDINALLY BETWEEN THE TWO TIEDOWN ANCHORS LOCATED ALONG ONE SIDE OF THE VEHICLE TO WHICH WEB STRAPS MARKED ① WILL BE ATTACHED. ALSO CENTER THE UNIT LATERALLY ACROSS THE VEHICLE WIDTH.
3. A TOTAL OF FOUR WEB STRAP TIEDOWN ASSEMBLIES ARE REQUIRED FOR THE LOAD SHOWN.

**KEY NUMBERS**

- ① WEB STRAP TIEDOWN ASSEMBLY (2 REQD). INSTALL EACH STRAP TO EXTEND FROM A TIEDOWN ANCHOR ON SIDE OF VEHICLE, OVER TOP OF PALLET UNIT, TO A TIEDOWN ANCHOR ON THE OPPOSITE SIDE OF THE VEHICLE.
- ② WEB STRAP TIEDOWN ASSEMBLY (2 REQD). INSTALL EACH STRAP TO EXTEND FROM A TIEDOWN ANCHOR ON ONE SIDE OF VEHICLE, AROUND PALLET AS SHOWN, TO A TIEDOWN ANCHOR ON THE OPPOSITE SIDE OF THE VEHICLE.

**LOAD AS SHOWN**

<u>ITEM</u>	<u>QUANTITY</u>	<u>WEIGHT (APPROX)</u>
PALLET UNIT	1	695 LBS



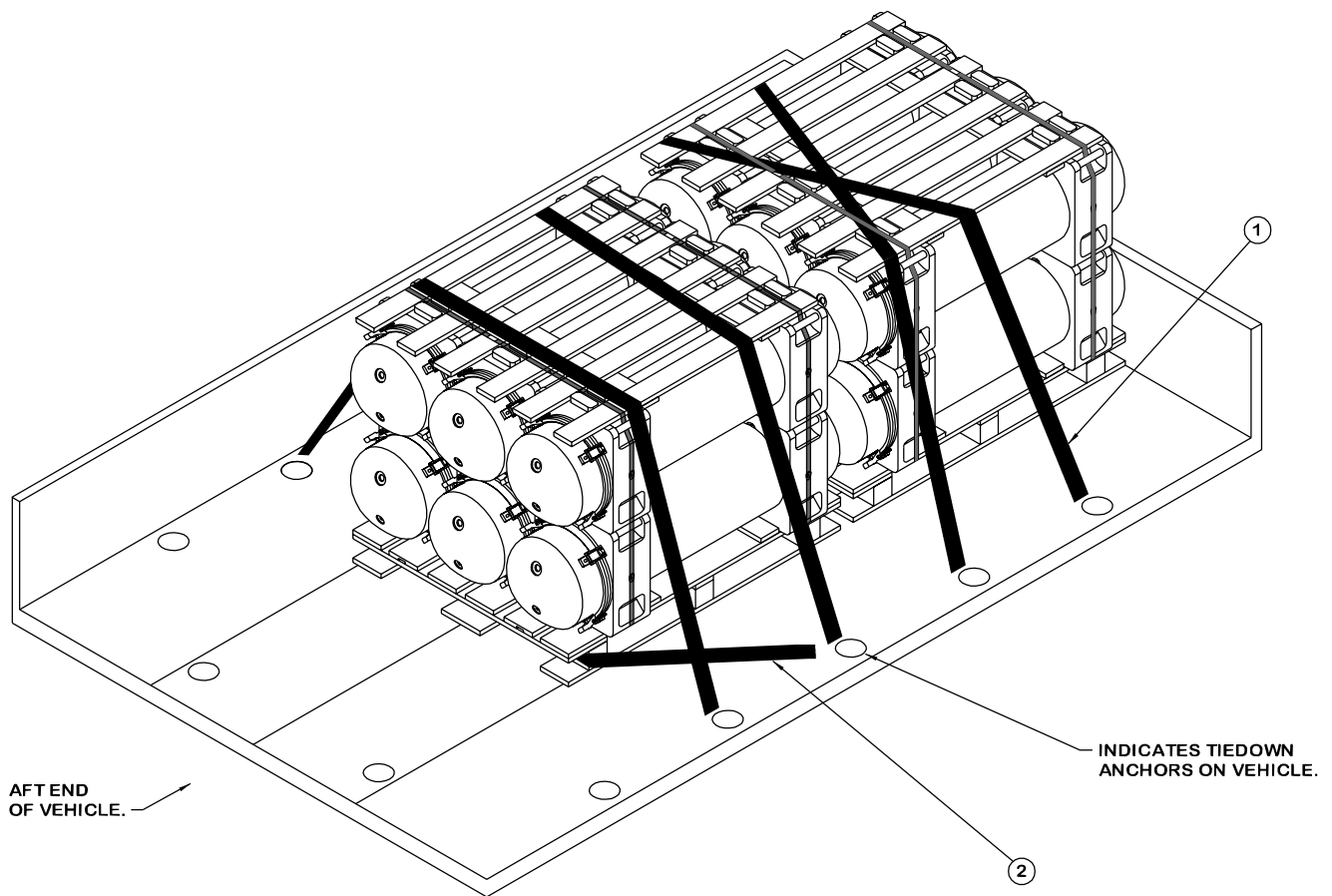

**ISOMETRIC VIEW**

**SPECIAL NOTES:**

1. A TYPICAL LOAD OF TWO PALLET UNITS IS SHOWN IN A 2-1/2 TON M1078 CARGO TRUCK HAVING INSIDE DIMENSIONS OF 149" LONG BY 91" WIDE.
2. PALLET UNITS MAY BE LOADED TWO UNITS HIGH, AS LONG AS THE CAPACITY OF THE VEHICLE IS NOT EXCEEDED. SEE THE LOADS ON PAGES 12, 15, AND 16 FOR DETAILS.
3. POSITION THE LOAD AGAINST THE FORWARD ENDWALL AND CENTER THE PALLET UNITS Laterally ACROSS THE VEHICLE WIDTH.
4. A TOTAL OF FIVE WEB STRAP TIEDOWN ASSEMBLIES ARE REQUIRED FOR THE LOAD SHOWN.

**KEY NUMBERS**

- ① WEB STRAP TIEDOWN ASSEMBLY (4 REQD). INSTALL EACH STRAP TO EXTEND FROM A TIEDOWN ANCHOR ON SIDE OF VEHICLE, OVER TOP OF PALLET UNIT, TO A TIEDOWN ANCHOR ON THE OPPOSITE SIDE OF THE VEHICLE.
- ② WEB STRAP TIEDOWN ASSEMBLY (1 REQD). INSTALL THE STRAP TO EXTEND FROM A TIEDOWN ANCHOR ON ONE SIDE OF VEHICLE, AROUND PALLET AS SHOWN, TO A TIEDOWN ANCHOR ON THE OPPOSITE SIDE OF THE VEHICLE.

**LOAD AS SHOWN**

<u>ITEM</u>	<u>QUANTITY</u>	<u>WEIGHT (APPROX)</u>
PALLET UNIT	2	1,390 LBS

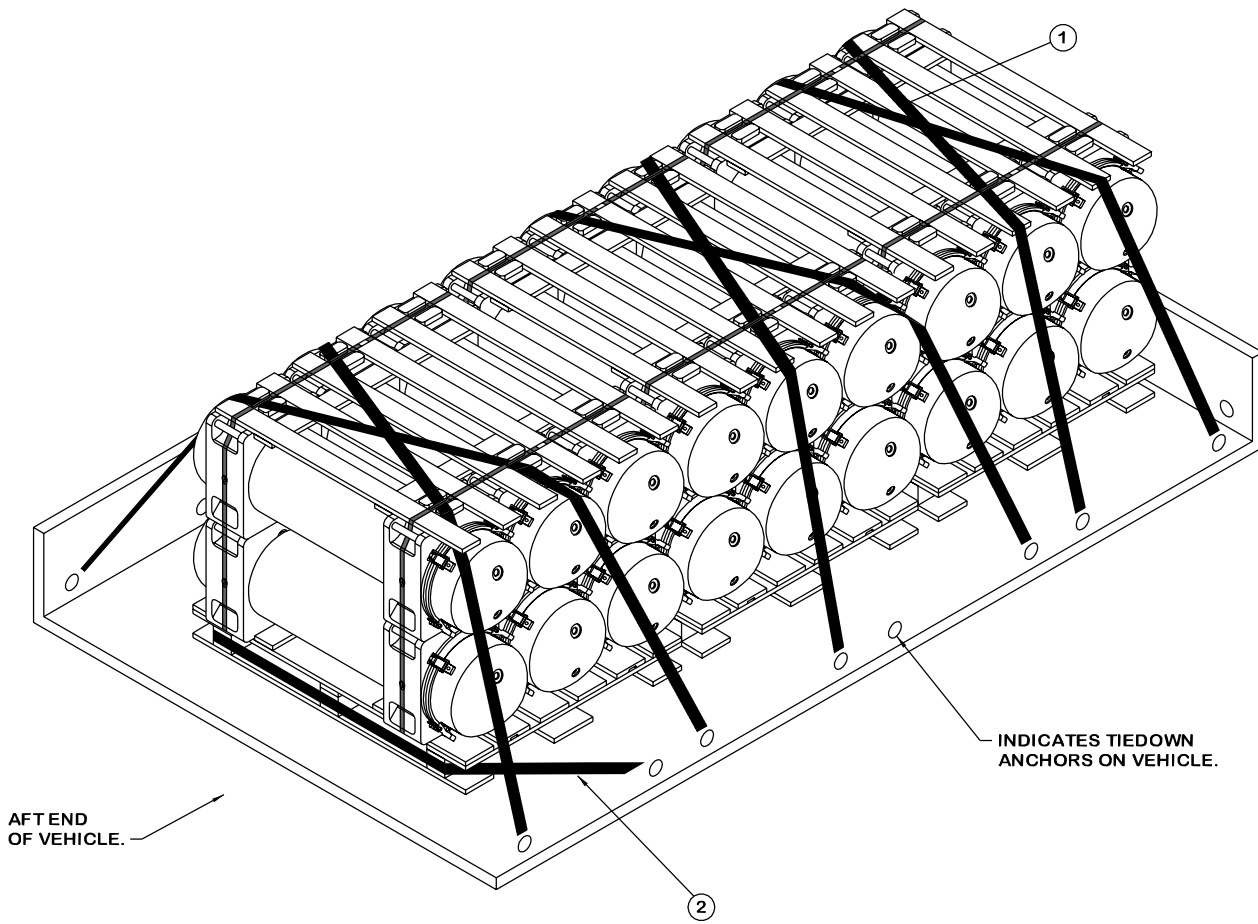

**ISOMETRIC VIEW**

**SPECIAL NOTES:**

1. A TYPICAL LOAD OF THREE PALLET UNITS IS SHOWN IN A 2-1/2 TON M35 CARGO TRUCK HAVING INSIDE DIMENSIONS OF 147" LONG BY 88" WIDE.
2. PALLET UNITS MAY BE LOADED TWO UNITS HIGH, AS LONG AS THE CAPACITY OF THE VEHICLE IS NOT EXCEEDED. SEE THE LOADS ON PAGES 12, 15 AND 16 FOR DETAILS.
3. POSITION THE LOAD AGAINST THE FORWARD ENDWALL AND CENTER THE PALLET UNITS Laterally ACROSS THE VEHICLE WIDTH.
4. A TOTAL OF SEVEN WEB STRAP TIEDOWN ASSEMBLIES ARE REQUIRED FOR THE LOAD SHOWN.

**KEY NUMBERS**

- ① WEB STRAP TIEDOWN ASSEMBLY (6 REQD). INSTALL EACH STRAP TO EXTEND FROM A TIEDOWN ANCHOR ON SIDE OF VEHICLE, OVER TOP OF PALLET UNIT, TO A TIEDOWN ANCHOR ON THE OPPOSITE SIDE OF THE VEHICLE.
- ② WEB STRAP TIEDOWN ASSEMBLY (1 REQD). INSTALL THE STRAP TO EXTEND FROM A TIEDOWN ANCHOR ON ONE SIDE OF VEHICLE, AROUND PALLET AS SHOWN, TO A TIEDOWN ANCHOR ON THE OPPOSITE SIDE OF THE VEHICLE.

**LOAD AS SHOWN**

<u>ITEM</u>	<u>QUANTITY</u>	<u>WEIGHT (APPROX)</u>
PALLET UNIT	3	2,085 LBS

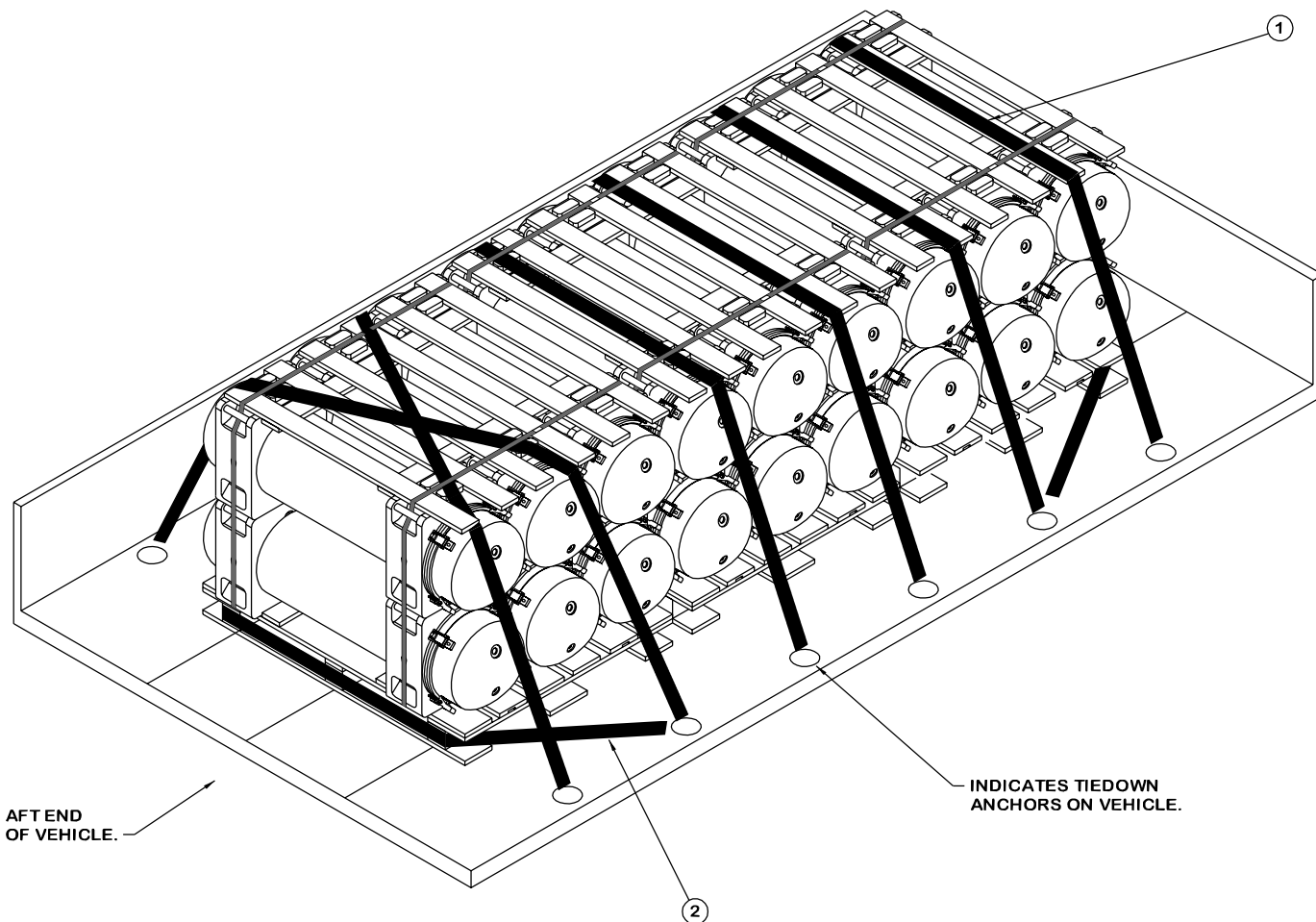

**ISOMETRIC VIEW**

**SPECIAL NOTES:**

1. A TYPICAL LOAD OF THREE PALLET UNITS IS SHOWN IN A 5 TON M1083 SHORT WHEEL BASE CARGO TRUCK HAVING INSIDE DIMENSIONS OF 170-1/4" LONG BY 91" WIDE.
2. PALLET UNITS MAY BE LOADED TWO UNITS HIGH, AS LONG AS THE CAPACITY OF THE VEHICLE IS NOT EXCEEDED. SEE THE LOADS ON PAGES 12, 15, AND 16 FOR DETAILS.
3. CENTER THE PALLET UNITS LONGITUDINALLY AND Laterally WITHIN THE VEHICLE CARGO AREA.
4. A TOTAL OF EIGHT WEB STRAP TIEDOWN ASSEMBLIES ARE REQUIRED FOR THE LOAD SHOWN.

**KEY NUMBERS**

- ① WEB STRAP TIEDOWN ASSEMBLY (6 REQD). INSTALL EACH STRAP TO EXTEND FROM A TIEDOWN ANCHOR ON SIDE OF VEHICLE, OVER TOP OF PALLET UNIT, TO A TIEDOWN ANCHOR ON THE OPPOSITE SIDE OF THE VEHICLE.
- ② WEB STRAP TIEDOWN ASSEMBLY (2 REQD). INSTALL EACH STRAP TO EXTEND FROM A TIEDOWN ANCHOR ON ONE SIDE OF VEHICLE, AROUND PALLET AS SHOWN, TO A TIEDOWN ANCHOR ON THE OPPOSITE SIDE OF THE VEHICLE.

**LOAD AS SHOWN**

<u>ITEM</u>	<u>QUANTITY</u>	<u>WEIGHT (APPROX)</u>
PALLET UNIT	3	2,085 LBS

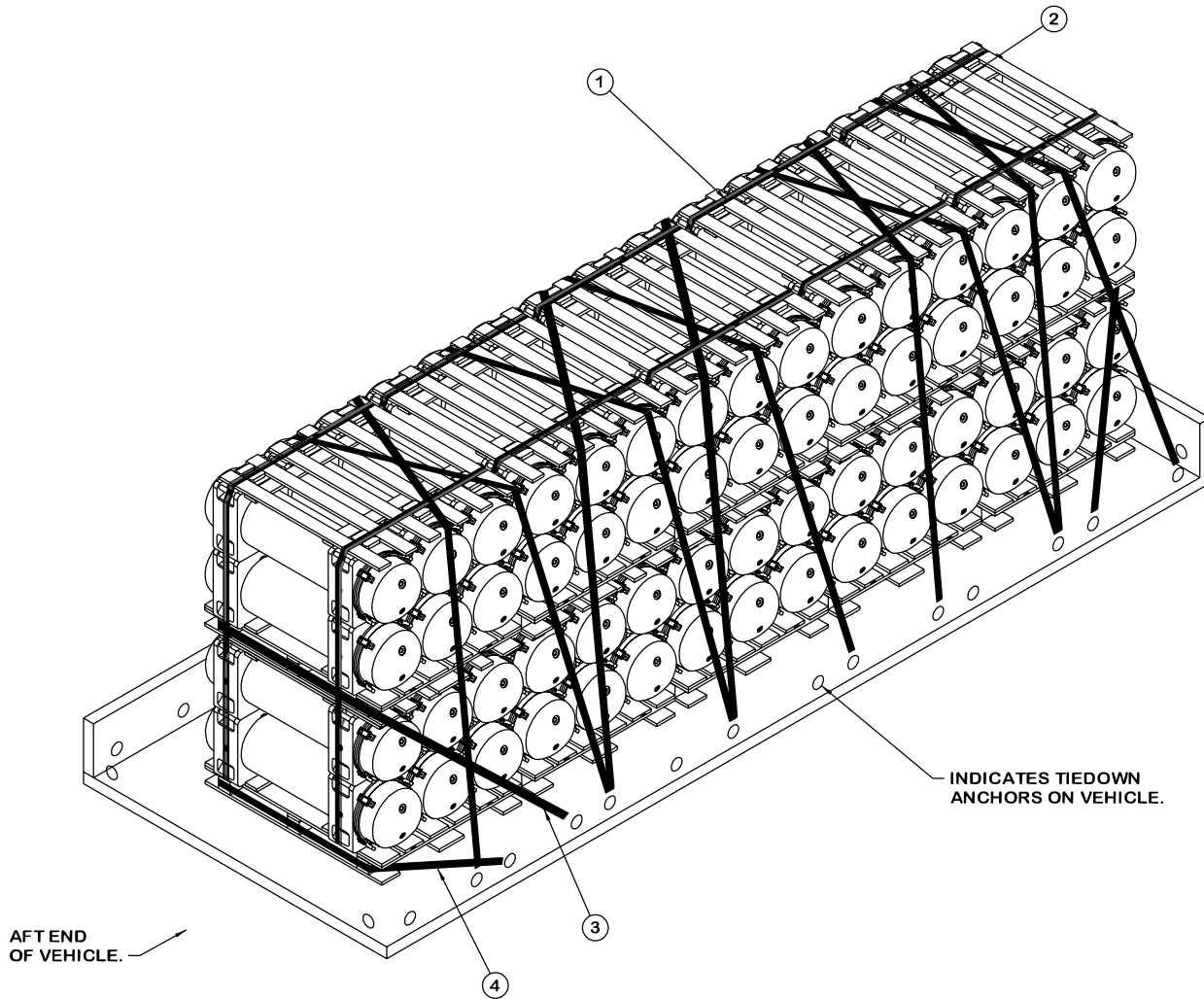

**ISOMETRIC VIEW**

**SPECIAL NOTES:**

1. A TYPICAL LOAD OF 10 PALLET UNITS IS SHOWN IN A 5 TON M927A1 CARGO TRUCK HAVING INSIDE DIMENSIONS OF 244" LONG BY 88" WIDE.
2. POSITION THE LOAD AGAINST THE FORWARD ENDWALL AND CENTER THE PALLET UNITS Laterally ACROSS THE VEHICLE WIDTH.
3. A TOTAL OF 43 WEB STRAP TIEDOWN ASSEMBLIES ARE REQUIRED FOR THE LOAD SHOWN.

**KEY NUMBERS**

- ① WEB STRAP TIEDOWN ASSEMBLY (10 REQD). HOOK TWO STRAPS TOGETHER AND ENCIRCLE EACH STACK OF TWO PALLET UNITS AT TWO PLACES.
- ② WEB STRAP TIEDOWN ASSEMBLY (10 REQD). HOOK TWO STRAPS TOGETHER AND INSTALL TO EXTEND FROM A TIEDOWN ANCHOR ON SIDE OF VEHICLE, OVER TOP OF LOAD, TO A TIEDOWN ANCHOR ON THE OPPOSITE SIDE OF THE VEHICLE.
- ③ WEB STRAP TIEDOWN ASSEMBLY (2 REQD). INSTALL THE STRAP TO EXTEND FROM A TIEDOWN ANCHOR ON ONE SIDE OF VEHICLE, AROUND WOODEN PALLET IN THE UPPER PALLET UNIT, TO A TIEDOWN ANCHOR ON THE OPPOSITE SIDE OF THE VEHICLE. DO NOT INSTALL OVER PIECE MARKED ①. THREAD BEHIND INSTALLED STRAP, FLUSH AGAINST THE PALLET.
- ④ WEB STRAP TIEDOWN ASSEMBLY (1 REQD). INSTALL THE STRAP TO EXTEND FROM A TIEDOWN ANCHOR ON ONE SIDE OF VEHICLE, AROUND THE WOODEN PALLET IN THE LOWER PALLET UNIT AT THE REAR OF THE LOAD, TO A TIEDOWN ANCHOR ON THE OPPOSITE SIDE OF THE VEHICLE.

**LOAD AS SHOWN**

ITEM	QUANTITY	WEIGHT (APPROX)
PALLET UNIT	10	6,950 LBS

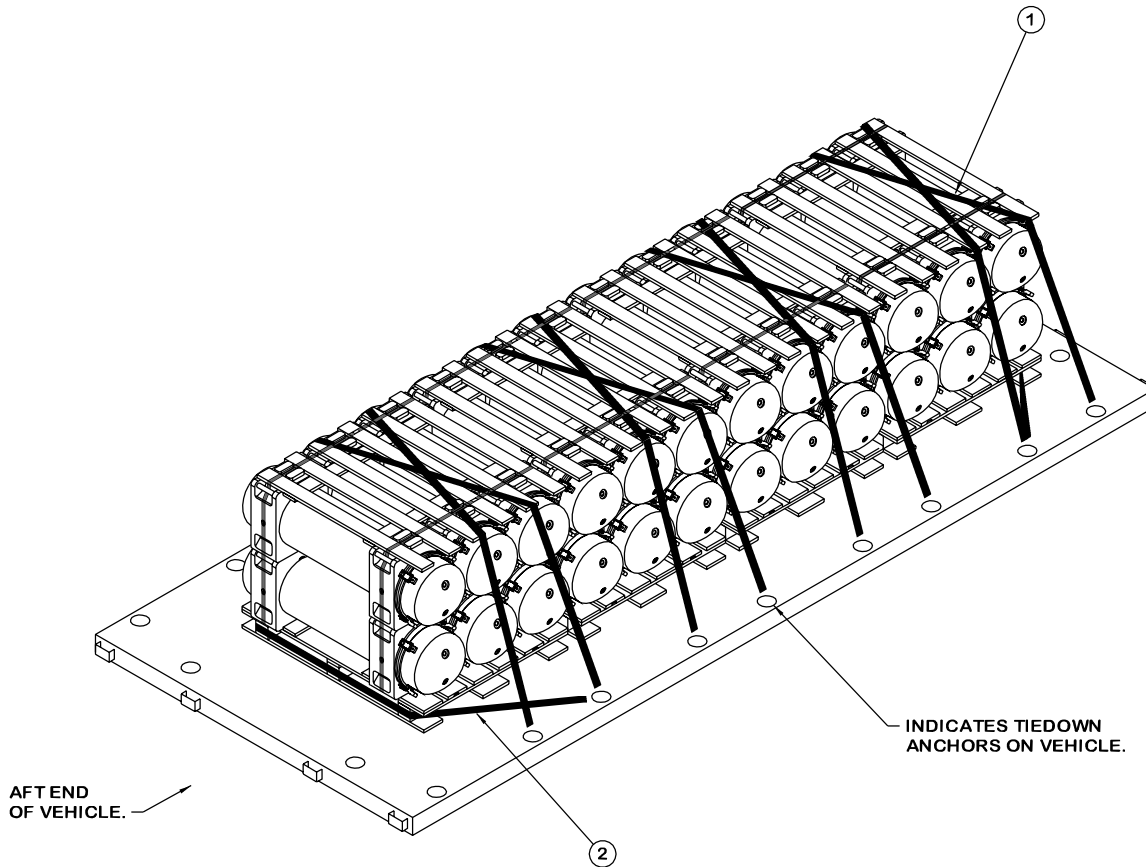

**ISOMETRIC VIEW**

**SPECIAL NOTES:**

1. A TYPICAL LOAD OF FOUR PALLET UNITS IS SHOWN ON A 10 TON M977 AND/OR M985 HEAVY EXPANDED MOBILITY TACTICAL TRUCK (HEMTT) HAVING INSIDE DIMENSIONS OF 216-3/8" LONG BY 90-3/4" WIDE.
2. PALLET UNITS MAY BE LOADED TWO UNITS HIGH, AS LONG AS THE CAPACITY OF THE VEHICLE IS NOT EXCEEDED. SEE THE LOADS ON PAGES 12, 15, AND 16 FOR DETAILS.
3. DO NOT POSITION THE LOAD AGAINST THE ENDWALLS. CENTER THE PALLET UNITS LONGITUDINALLY AND LATERALLY WITHIN THE VEHICLE CARGO AREA.
4. A TOTAL OF 10 WEB STRAP TIEDOWN ASSEMBLIES ARE REQUIRED FOR THE LOAD SHOWN.

**KEY NUMBERS**

- ① WEB STRAP TIEDOWN ASSEMBLY (8 REQD). INSTALL EACH STRAP TO EXTEND FROM A TIEDOWN ANCHOR ON SIDE OF VEHICLE, OVER TOP OF PALLET UNIT, TO A TIEDOWN ANCHOR ON THE OPPOSITE SIDE OF THE VEHICLE.
- ② WEB STRAP TIEDOWN ASSEMBLY (2 REQD). INSTALL EACH STRAP TO EXTEND FROM A TIEDOWN ANCHOR ON ONE SIDE OF VEHICLE, AROUND PALLET AS SHOWN, TO A TIEDOWN ANCHOR ON THE OPPOSITE SIDE OF THE VEHICLE.

**LOAD AS SHOWN**

<u>ITEM</u>	<u>QUANTITY</u>	<u>WEIGHT (APPROX)</u>
PALLET UNIT	4	2,780 LBS

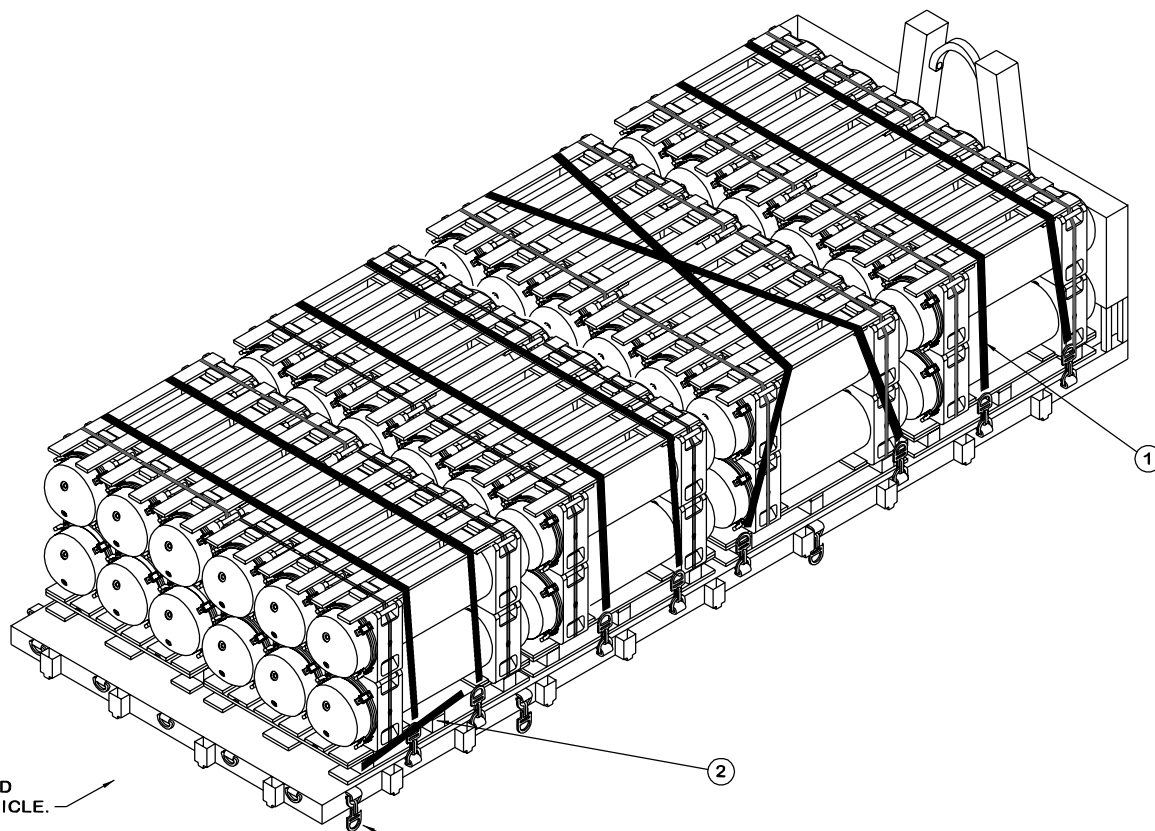

**ISOMETRIC VIEW**

INDICATES TIEDOWN ANCHORS ON VEHICLE.

**SPECIAL NOTES:**

1. A TYPICAL LOAD OF EIGHT PALLET UNITS IS SHOWN ON A 16-1/2 TON M1077 PLS A-FRAME FLATRACK HAVING CARGO DECK DIMENSIONS OF 228" LONG BY 90-1/2" WIDE.
2. PALLET UNITS MAY BE LOADED TWO UNITS HIGH, AS LONG AS THE CAPACITY OF THE VEHICLE IS NOT EXCEEDED. SEE THE LOADS ON PAGES 12, 15, AND 16 FOR DETAILS.
3. POSITION THE LOAD AGAINST THE A-FRAME AND CENTER THE PALLET UNITS Laterally ACROSS THE WIDTH OF THE FLATRACK.
4. A TOTAL OF NINE WEB STRAP TIEDOWN ASSEMBLIES ARE REQUIRED FOR THE LOAD SHOWN.

**KEY NUMBERS**

- ① WEB STRAP TIEDOWN ASSEMBLY (8 REQD). INSTALL EACH STRAP TO EXTEND FROM A TIEDOWN ANCHOR ON SIDE OF FLATRACK, OVER TOP OF PALLET UNIT, TO A TIEDOWN ANCHOR ON THE OPPOSITE SIDE OF FLATRACK.
- ② WEB STRAP TIEDOWN ASSEMBLY (1 REQD). INSTALL THE STRAP TO EXTEND FROM A TIEDOWN ANCHOR ON ONE SIDE OF FLATRACK, AROUND PALLETS AS SHOWN, TO A TIEDOWN ANCHOR ON THE OPPOSITE SIDE OF FLATRACK.

**LOAD AS SHOWN**

ITEM	QUANTITY	WEIGHT (APPROX)
PALLET UNIT	8	5,560 LBS

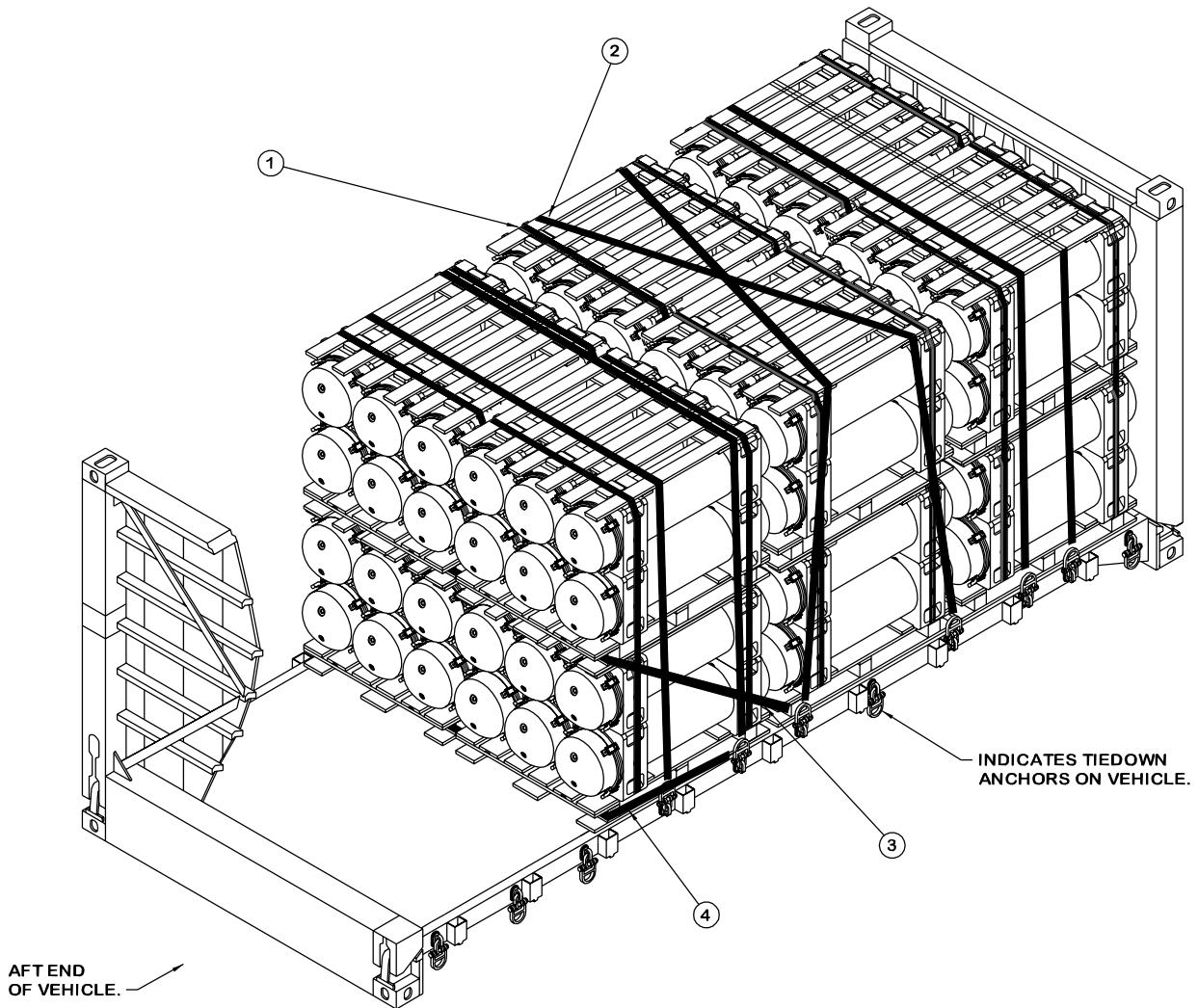

**ISOMETRIC VIEW**

**SPECIAL NOTES:**

1. A TYPICAL LOAD OF 12 PALLET UNITS IS SHOWN ON AN M1 PLS FLATRACK HAVING INSIDE DIMENSIONS OF 222" LONG BY 90" WIDE, AND A MAXIMUM TACTICAL LOAD WEIGHT OF 28,750 POUNDS.
2. POSITION THE LOAD AGAINST THE FORWARD ENDWALL AND CENTER THE PALLET UNITS Laterally ACROSS THE WIDTH OF THE FLATRACK.
3. A TOTAL OF 26 WEB STRAP TIEDOWN ASSEMBLIES ARE REQUIRED FOR THE LOAD SHOWN.

**KEY NUMBERS**

- ① WEB STRAP TIEDOWN ASSEMBLY (6 REQD). HOOK TWO STRAPS TOGETHER AND ENCIRCLE EACH STACK OF FOUR PALLET UNITS AT TWO PLACES.
- ② WEB STRAP TIEDOWN ASSEMBLY (6 REQD). HOOK TWO STRAPS TOGETHER AND INSTALL TO EXTEND FROM A TIEDOWN ANCHOR ON SIDE OF VEHICLE, OVER TOP OF PALLET UNITS, TO A TIEDOWN ANCHOR ON THE OPPOSITE SIDE OF THE VEHICLE.
- ③ WEB STRAP TIEDOWN ASSEMBLY (1 REQD). INSTALL THE STRAP TO EXTEND FROM A TIEDOWN ANCHOR ON ONE SIDE OF VEHICLE, AROUND WOODEN PALLETS IN UPPER LAYER, TO A TIEDOWN ANCHOR ON THE OPPOSITE SIDE OF THE VEHICLE.
- ④ WEB STRAP TIEDOWN ASSEMBLY (1 REQD). INSTALL THE STRAP TO EXTEND FROM A TIEDOWN ANCHOR ON ONE SIDE OF VEHICLE, AROUND WOODEN PALLETS IN LOWER LAYER, TO A TIEDOWN ANCHOR ON THE OPPOSITE SIDE OF THE VEHICLE.

**LOAD AS SHOWN**

<u>ITEM</u>	<u>QUANTITY</u>	<u>WEIGHT (APPROX)</u>
PALLET UNIT	12	8,340 LBS

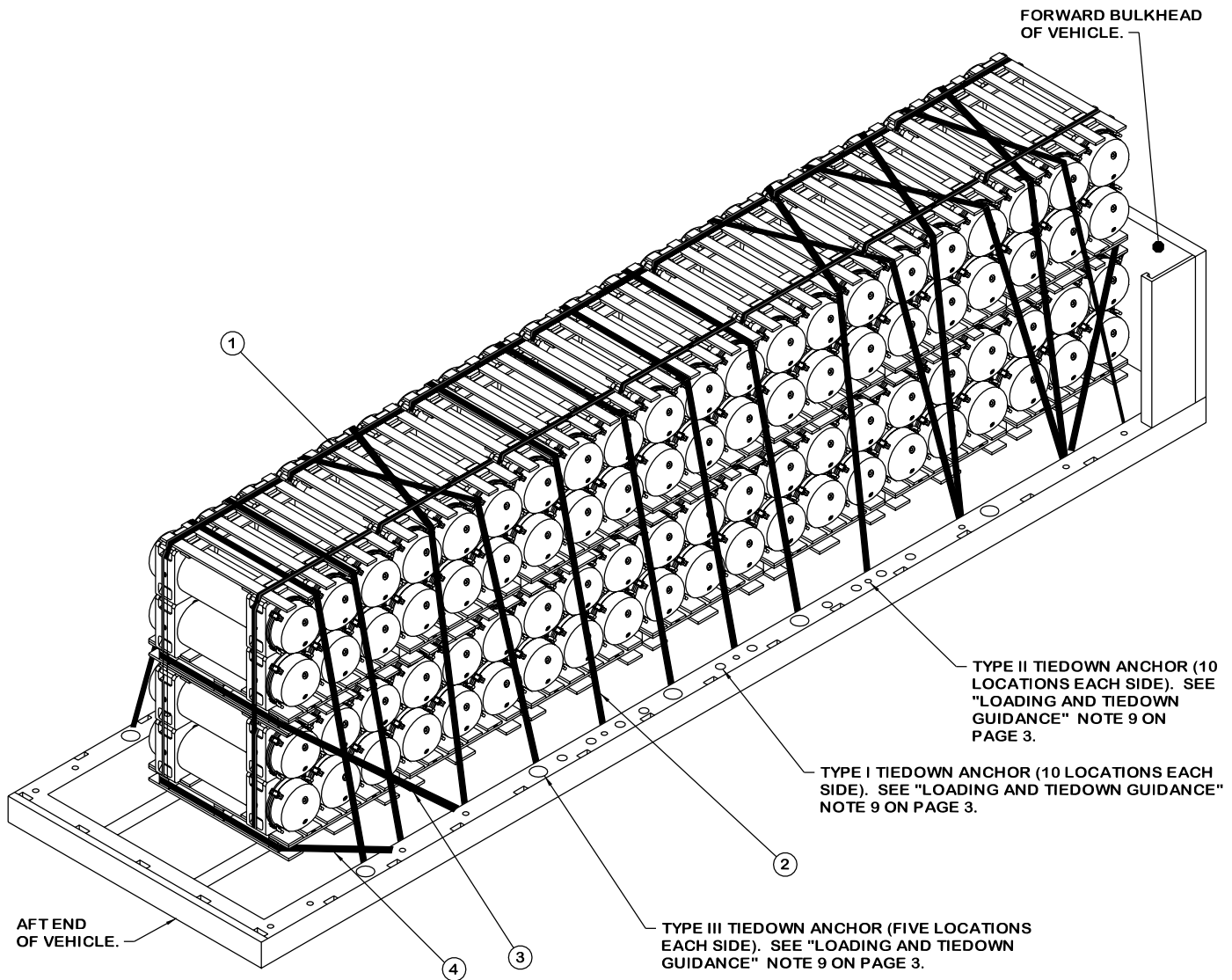

**ISOMETRIC VIEW**

**SPECIAL NOTES:**

1. A TYPICAL LOAD OF 14 PALLET UNITS IS SHOWN ON A 22-1/2 TON M871 SEMITRAILER HAVING INSIDE DIMENSIONS OF 354" LONG BY 96" WIDE.
2. POSITION THE LOAD AGAINST THE FORWARD BULKHEAD AND CENTER THE PALLET UNITS LATERALLY ACROSS THE VEHICLE WIDTH.
3. IF THE FORWARD BULKHEAD HAS ENDWALL TIEDOWN RINGS THAT PREVENT THE LOAD FROM BEING POSITIONED AGAINST IT, ONE MORE STRAP MARKED ④ WILL BE REQUIRED AT THE FORWARD END OF THE LOAD.
4. A TOTAL OF 59 WEB STRAP ASSEMBLIES ARE REQUIRED FOR THE LOAD SHOWN.

**LOAD AS SHOWN**

ITEM	QUANTITY	WEIGHT (APPROX)
PALLET UNIT	14	9,730 LBS

**KEY NUMBERS**

- ① WEB STRAP TIEDOWN ASSEMBLY (14 REQD). HOOK TWO STRAPS TOGETHER AND ENCIRCLE EACH STACK OF TWO PALLET UNITS AT TWO PLACES.
- ② WEB STRAP TIEDOWN ASSEMBLY (14 REQD). HOOK TWO STRAPS TOGETHER AND INSTALL TO EXTEND FROM A TIEDOWN ANCHOR ON SIDE OF VEHICLE, OVER TOP OF LOAD, TO A TIEDOWN ANCHOR ON THE OPPOSITE SIDE OF THE VEHICLE.
- ③ WEB STRAP TIEDOWN ASSEMBLY (2 REQD). INSTALL THE STRAP TO EXTEND FROM A TIEDOWN ANCHOR ON ONE SIDE OF VEHICLE, AROUND WOODEN PALLET IN THE UPPER PALLET UNIT, TO A TIEDOWN ANCHOR ON THE OPPOSITE SIDE OF THE VEHICLE. DO NOT INSTALL OVER PIECE MARKED ①, THREAD BEHIND INSTALLED STRAP, FLUSH AGAINST THE PALLET.
- ④ WEB STRAP TIEDOWN ASSEMBLY (1 REQD). INSTALL THE STRAP TO EXTEND FROM A TIEDOWN ANCHOR ON ONE SIDE OF VEHICLE, AROUND THE WOODEN PALLET IN THE LOWER PALLET UNIT AT THE REAR OF THE LOAD, TO A TIEDOWN ANCHOR ON THE OPPOSITE SIDE OF THE VEHICLE.



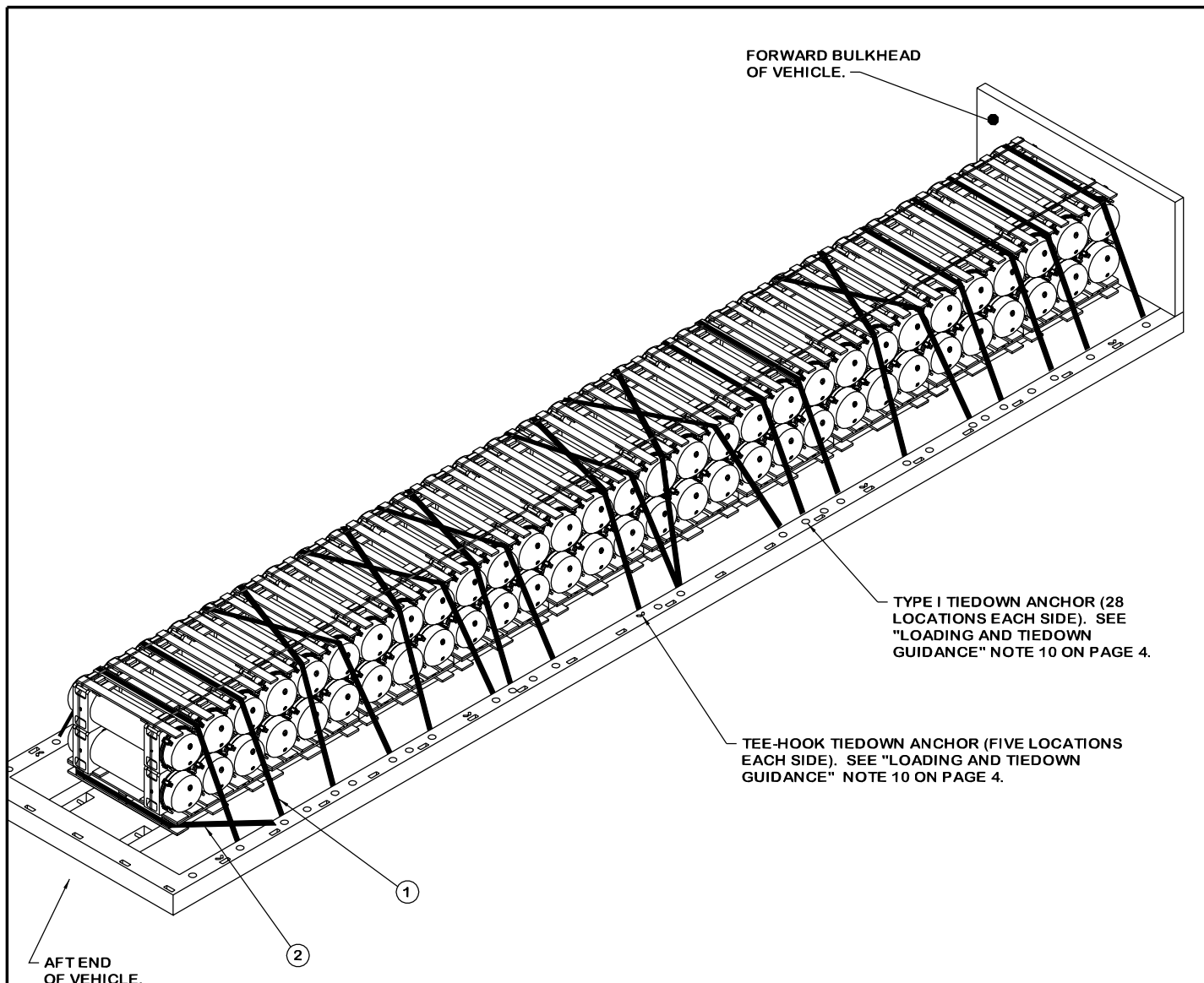

FORWARD BULKHEAD OF VEHICLE.

TYPE I TIEDOWN ANCHOR (28 LOCATIONS EACH SIDE). SEE "LOADING AND TIEDOWN GUIDANCE" NOTE 10 ON PAGE 4.

TEE-HOOK TIEDOWN ANCHOR (FIVE LOCATIONS EACH SIDE). SEE "LOADING AND TIEDOWN GUIDANCE" NOTE 10 ON PAGE 4.

AFT END OF VEHICLE.

**ISOMETRIC VIEW**

**SPECIAL NOTES:**

1. A TYPICAL LOAD OF 10 PALLET UNITS IS SHOWN ON A 34 TON M872 SEMITRAILER HAVING INSIDE DIMENSIONS OF 489-1/2" LONG BY 96" WIDE.
2. PALLET UNITS MAY BE LOADED TWO UNITS HIGH, AS LONG AS THE CAPACITY OF THE VEHICLE IS NOT EXCEEDED. SEE THE LOADS ON PAGES 12, 15, AND 16 FOR DETAILS.
3. POSITION THE LOAD AGAINST THE FORWARD BULKHEAD AND CENTER THE PALLET UNITS Laterally ACROSS THE VEHICLE WIDTH.
4. IF THE FORWARD BULKHEAD HAS GUSSET SUPPORT PIECES THAT PREVENT THE LOAD FROM BEING POSITIONED AGAINST IT, ONE MORE STRAP MARKED ② WILL BE REQUIRED AT THE FORWARD END OF THE LOAD.
5. A TOTAL OF 21 WEB STRAP ASSEMBLIES ARE REQUIRED FOR THE LOAD SHOWN.

**KEY NUMBERS**

- ① WEB STRAP TIEDOWN ASSEMBLY (20 REQD). INSTALL EACH STRAP TO EXTEND FROM A TIEDOWN ANCHOR ON SIDE OF VEHICLE, OVER TOP OF PALLET UNIT, TO A TIEDOWN ANCHOR ON THE OPPOSITE SIDE OF THE VEHICLE.
- ② WEB STRAP TIEDOWN ASSEMBLY (1 REQD). INSTALL THE STRAP TO EXTEND FROM A TIEDOWN ANCHOR ON ONE SIDE OF VEHICLE, AROUND WOODEN PALLET AS SHOWN, TO A TIEDOWN ANCHOR ON THE OPPOSITE SIDE OF THE VEHICLE.

**LOAD AS SHOWN**

ITEM	QUANTITY	WEIGHT (APPROX)
PALLET UNIT	10	6,950 LBS

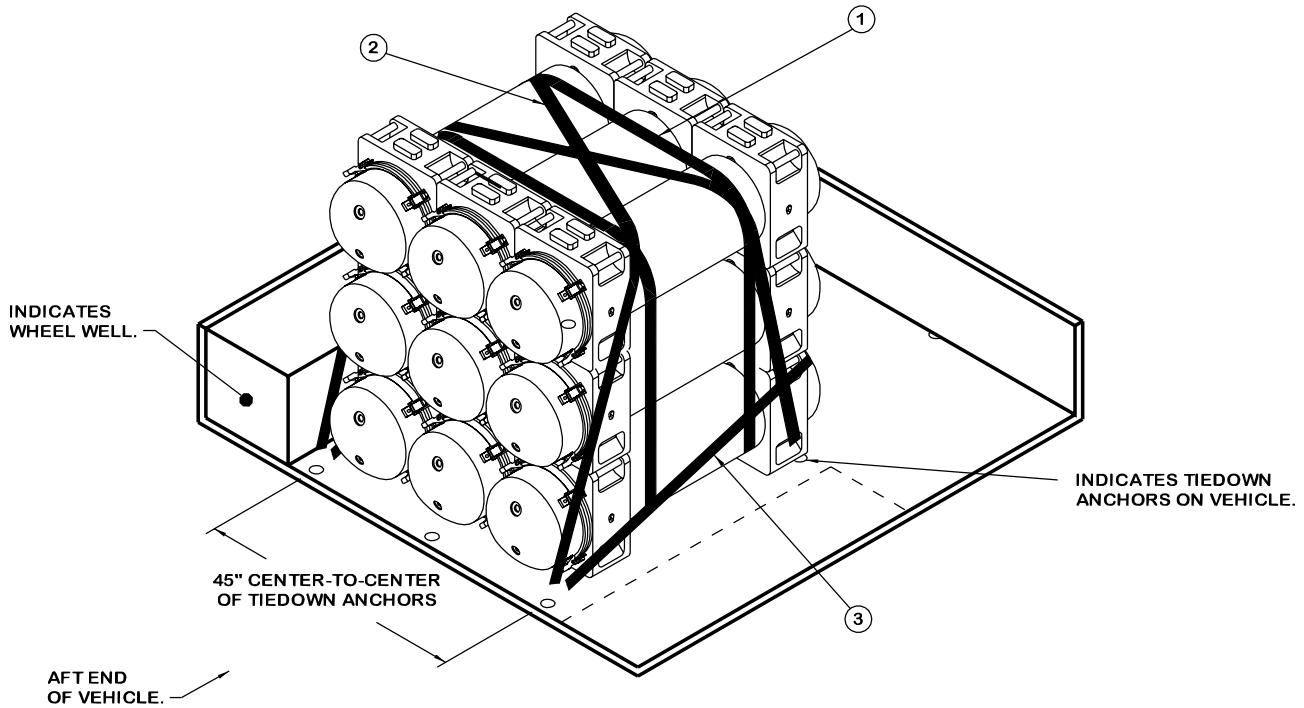

**ISOMETRIC VIEW**

**SPECIAL NOTES:**

1. A TYPICAL LOAD OF NINE LOOSE CONTAINERS IS SHOWN IN A 1-1/4 TON M998 HIGH MOBILITY MULTIPURPOSE WHEELED VEHICLE (HMMWV) HAVING INSIDE DIMENSIONS OF 83-1/4" LONG BY 84" WIDE (52" BETWEEN WHEEL WELLS).
2. WHEN LOADING A HMMWV, THE PROVISIONS STATED IN "LOADING AND TIEDOWN GUIDANCE" NOTE 6 ON PAGE 3 MUST BE COMPLIED WITH, I.E., ONLY FRONT-TO-REAR LONGITUDINAL PULL MUST BE APPLIED TO THE VEHICLE TIEDOWN ANCHORS, NOT SIDE-TO-SIDE LATERAL PULL.
3. POSITION THE CONTAINERS AGAINST THE TAILGATE, THREE CONTAINERS WIDE AND THREE CONTAINERS HIGH AND CENTERED BETWEEN THE WHEEL WELLS, AS SHOWN. DO NOT COVER CARGO TIEDOWN ANCHORS. CAUTION: NEVER POSITION THE LOAD AGAINST THE FORWARD BULKHEAD, LOAD SECURING WEB STRAPS MAY ONLY BE ATTACHED TO THE TIEDOWN ANCHORS LOCATED BETWEEN THE WHEEL WELLS. DUE TO THE LOCATION OF THE REARMOST TIEDOWN ANCHORS, THE HOLD-DOWN STRAPS, PIECE MARKED ②, MUST BE CROSSED OVER THE TOP OF THE LOAD.
4. A TOTAL OF FIVE WEB STRAP TIEDOWN ASSEMBLIES ARE REQUIRED FOR THE LOAD SHOWN.

**KEY NUMBERS**

- ① WEB STRAP TIEDOWN ASSEMBLY (2 REQD). INSTALL EACH STRAP TO ENCIRCLE ALL CONTAINERS IN THE BUNDLE. PRE-POSITION THESE TWO STRAPS ON THE FLOOR OF THE VEHICLE, AT THE PROPER LOCATION, PRIOR TO LOADING CONTAINERS. MAKE SURE STRAPS LAY FLAT ACROSS THE FLOOR AND POSITION BOTH STRAP RATCHETS ON THE SAME SIDE OF THE VEHICLE. AFTER ALL THE CONTAINERS ARE STACKED, BRING ENDS OF STRAPS OVER TOP OF LOAD AND HOOK ENDS TOGETHER.
- ② WEB STRAP TIEDOWN ASSEMBLY (2 REQD). INSTALL EACH STRAP TO EXTEND FROM A TIEDOWN ANCHOR ON SIDE OF VEHICLE, OVER TOP OF CONTAINERS, TO A TIEDOWN ANCHOR ON THE OPPOSITE SIDE OF THE VEHICLE. CROSS STRAPS OVER THE TOP OF THE LOAD AS SHOWN.
- ③ WEB STRAP TIEDOWN ASSEMBLY (1 REQD). INSTALL THE STRAP TO EXTEND FROM A TIEDOWN ANCHOR ON ONE SIDE OF VEHICLE, AROUND THE BOTTOM LAYER OF CONTAINERS AS SHOWN, TO A TIEDOWN ANCHOR ON THE OPPOSITE SIDE OF THE VEHICLE.

**LOAD AS SHOWN**

ITEM	QUANTITY	WEIGHT (APPROX)
CONTAINER	9	864 LBS

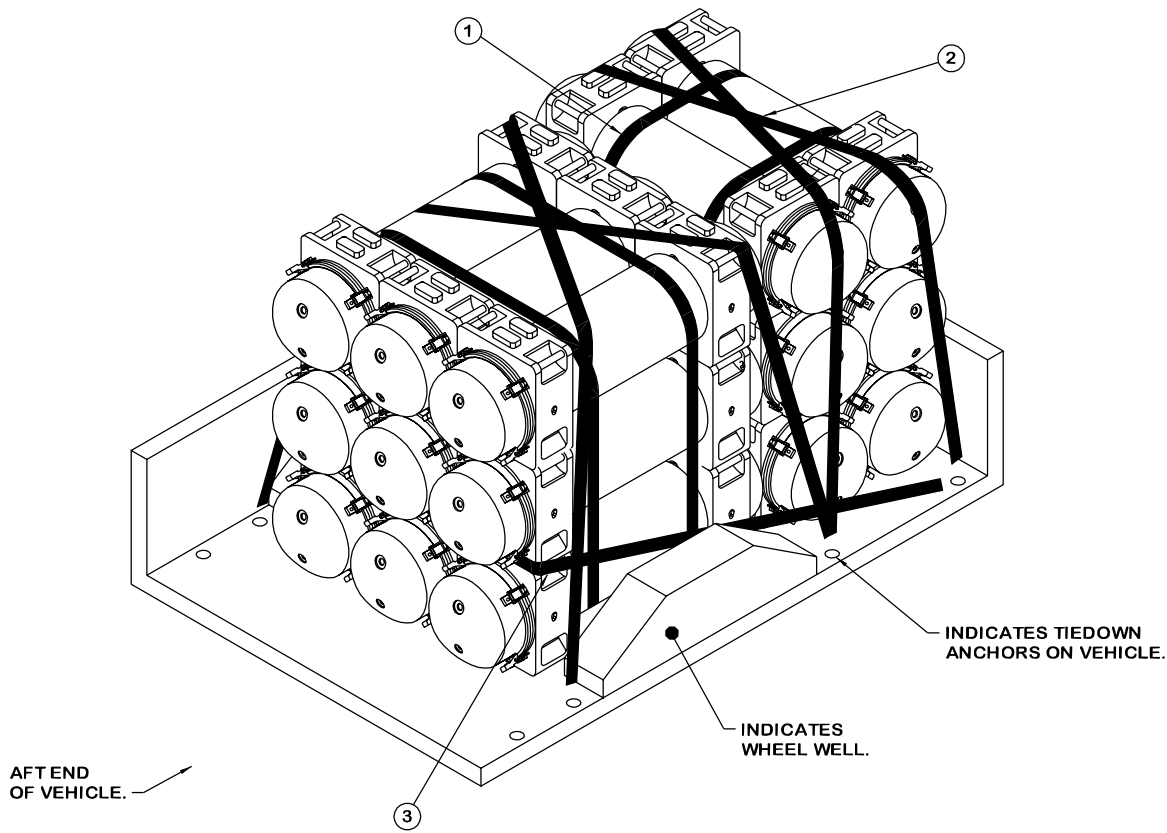

**ISOMETRIC VIEW**

**SPECIAL NOTES:**

1. A TYPICAL LOAD OF 15 LOOSE CONTAINERS IS SHOWN IN A 1-1/4 TON M1008 COMMERCIAL UTILITY CARGO VEHICLE (CUCV) HAVING INSIDE DIMENSIONS OF 98" LONG BY 65" WIDE.
2. POSITION THE LOAD AGAINST THE FORWARD ENDWALL AND CENTER THE CONTAINERS LATERALLY ACROSS THE VEHICLE WIDTH.
3. A TOTAL OF NINE WEB STRAP TIEDOWN ASSEMBLIES ARE REQUIRED FOR THE LOAD SHOWN.

**KEY NUMBERS**

- ① WEB STRAP TIEDOWN ASSEMBLY (4 REQD, 2 FOR EACH BUNDLE). INSTALL EACH STRAP TO ENCIROLE ALL CONTAINERS IN THE BUNDLE. PRE-POSITION THESE STRAPS ON THE FLOOR OF THE VEHICLE, AT THE PROPER LOCATION, PRIOR TO LOADING CONTAINERS. MAKE SURE STRAPS LAY FLAT ACROSS THE FLOOR AND DRAPE THE ENDS OVER THE SIDE OF THE VEHICLE. AFTER ALL THE CONTAINERS IN A BUNDLE ARE STACKED, BRING ENDS OF STRAPS OVER TOP OF LOAD AND HOOK ENDS TOGETHER. THE RATCHETS MAY BE POSITIONED ANYWHERE ACROSS THE TOP OF THE STACK OR SINGLE LAYER ROW.
- ② WEB STRAP TIEDOWN ASSEMBLY (4 REQD). INSTALL EACH STRAP TO EXTEND FROM A TIEDOWN ANCHOR ON SIDE OF VEHICLE, OVER TOP OF CONTAINERS, TO A TIEDOWN ANCHOR ON THE OPPOSITE SIDE OF THE VEHICLE. POSITION THE STRAPS STRAIGHT ACROSS THE BUNDLE IF POSSIBLE, HOWEVER, DUE TO THE LOCATION AND QUANTITY OF TIEDOWN ANCHORS, IT MAY BE NECESSARY TO POSITION THESE STRAPS DIAGONALLY ACROSS THE BUNDLE.
- ③ WEB STRAP TIEDOWN ASSEMBLY (1 REQD). INSTALL THE STRAP TO EXTEND FROM A TIEDOWN ANCHOR ON ONE SIDE OF VEHICLE, AROUND THE BOTTOM LAYER OF CONTAINERS AS SHOWN, TO A TIEDOWN ANCHOR ON THE OPPOSITE SIDE OF THE VEHICLE.

**LOAD AS SHOWN**

ITEM	QUANTITY	WEIGHT (APPROX)
CONTAINER	----- 15 -----	----- 1,440 LBS

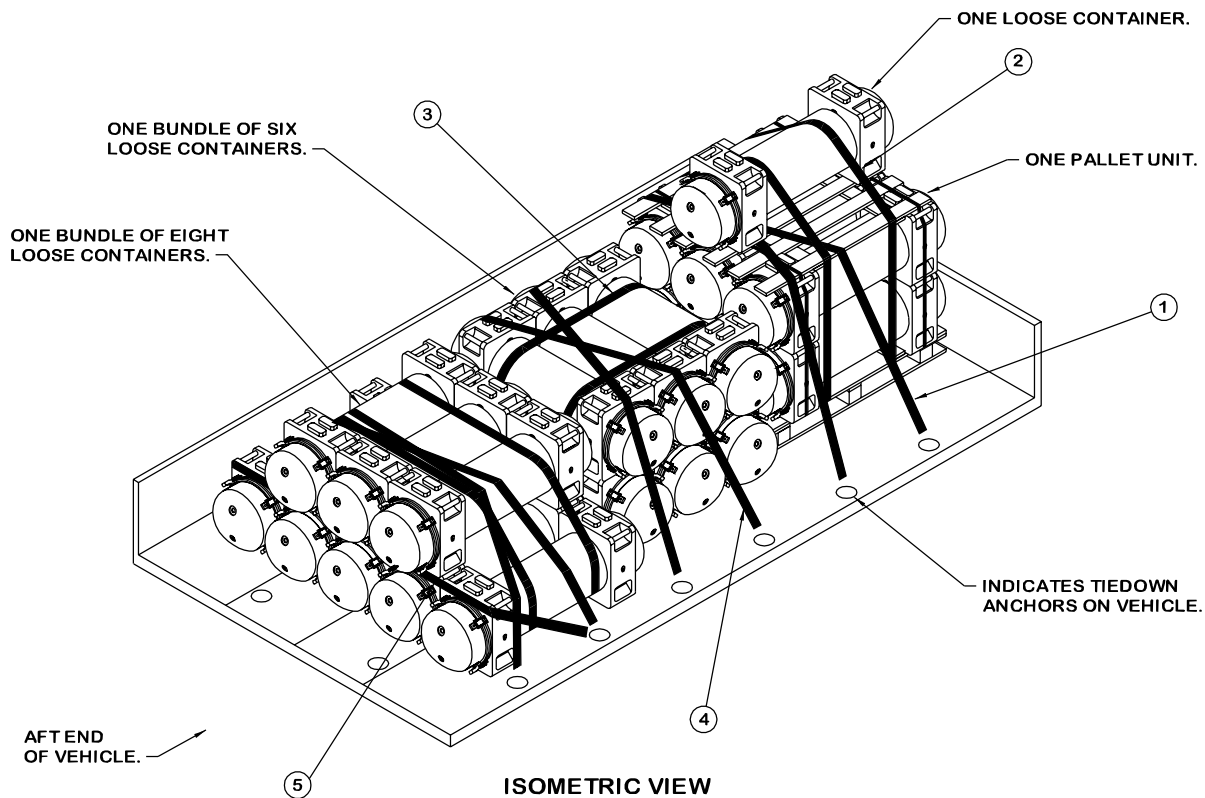

**ISOMETRIC VIEW**

**SPECIAL NOTES:**

1. A TYPICAL LOAD OF 15 LOOSE CONTAINERS AND ONE PALLET UNIT ARE SHOWN IN A 5 TON M1083 CARGO TRUCK HAVING INSIDE DIMENSIONS OF 170-1/4" LONG BY 91" WIDE.
2. THE PROCEDURES SHOWN ABOVE DEPICT METHODS OF SECURING PALLET UNITS AND/OR LOOSE CONTAINERS ON THE VEHICLE FLOOR AND/OR ON TOP OF A PALLET UNIT WHICH IS SECURED TO THE VEHICLE. HOLD DOWN STRAPS MARKED ① ARE POSITIONED OVER TOP OF THE PALLET UNIT AND MUST NOT BE POSITIONED OVER TOP OF LOOSE CONTAINER(S) ON TOP OF THE PALLET UNIT. SEE KEY NUMBERS ① AND ② AT RIGHT FOR GUIDANCE WHEN LOADING LOOSE CONTAINERS ON TOP OF A PALLET UNIT.
3. THE PALLET UNIT IS POSITIONED AGAINST THE FORWARD END-WALL AND ONE LOOSE CONTAINER IS POSITIONED ON TOP OF THE PALLET UNIT. ONE BUNDLE OF SIX LOOSE CONTAINERS AND ONE BUNDLE OF EIGHT LOOSE CONTAINERS ARE POSITIONED ON THE VEHICLE FLOOR, TIGHT AGAINST THE PALLET UNIT AND EACH OTHER. IF THE LOAD IS NOT POSITIONED AGAINST A FORWARD ENDWALL, ONE ADDITIONAL STRAP MARKED ⑤ IS REQUIRED AT THE FORWARD END.
4. THE QUANTITY OF LOOSE CONTAINERS THAT CAN BE SECURED ON TOP OF A PALLET UNIT MAY BE ONE OR TWO CONTAINERS. ALL LOOSE CONTAINERS POSITIONED ON TOP OF A PALLET UNIT MUST BE SECURED TO THE PALLET UNIT WITH TWO UNITIZING STRAPS AS SHOWN.
5. A TOTAL OF 13 WEB STRAP TIEDOWN ASSEMBLIES ARE REQUIRED FOR THE LOAD SHOWN.

**KEY NUMBERS**

- ① WEB STRAP TIEDOWN ASSEMBLY (2 REQD). INSTALL STRAP TO EXTEND FROM A TIEDOWN ANCHOR ON SIDE OF VEHICLE, OVER TOP OF PALLET UNIT, TO A TIEDOWN ANCHOR ON THE OPPOSITE SIDE OF THE VEHICLE. NOTE: STRAPS MARKED ① MUST BE INSTALLED OVER TOP OF THE PALLET UNIT PRIOR TO POSITIONING THE LOOSE CONTAINER(S) ON TOP.
- ② WEB STRAP TIEDOWN ASSEMBLY (2 REQD). POSITION LOOSE CONTAINER ON TOP OF PALLET UNIT. INSTALL EACH STRAP TO ENCIRCLE THE PALLET UNIT AND LOOSE CONTAINER. THREAD STRAP UNDER DECK OF PALLET UNIT, BRING ENDS OF STRAPS UP OVER TOP OF LOOSE CONTAINERS AND HOOK ENDS TOGETHER.
- ③ WEB STRAP TIEDOWN ASSEMBLY (4 REQD, 2 FOR EACH BUNDLE). INSTALL EACH STRAP TO ENCIRCLE ALL CONTAINERS IN THE BUNDLE. PRE-POSITION THESE STRAPS ON THE FLOOR OF THE VEHICLE, AT THE PROPER LOCATIONS, PRIOR TO LOADING CONTAINERS. MAKE SURE STRAPS LAY FLAT ACROSS THE FLOOR. AFTER ALL CONTAINERS IN A BUNDLE ARE STACKED, BRING ENDS OF STRAPS UP OVER TOP OF STACK, HOOK ENDS OF STRAPS TOGETHER. THE RATCHETS MAY BE POSITIONED ANYWHERE ACROSS THE TOP OF THE STACK OR SINGLE LAYER ROW.
- ④ WEB STRAP TIEDOWN ASSEMBLY (4 REQD). INSTALL EACH STRAP TO EXTEND FROM A TIEDOWN ANCHOR ON SIDE OF VEHICLE, OVER TOP OF BUNDLE, TO A TIEDOWN ANCHOR ON THE OPPOSITE SIDE OF THE VEHICLE. POSITION THE STRAPS STRAIGHT ACROSS THE BUNDLE IF POSSIBLE, HOWEVER, DUE TO THE LOCATION AND QUANTITY OF TIEDOWN ANCHORS, IT MAY BE NECESSARY TO POSITION THESE STRAPS DIAGONALLY ACROSS THE BUNDLE.
- ⑤ WEB STRAP TIEDOWN ASSEMBLY (1 REQD). INSTALL STRAP TO EXTEND FROM A TIEDOWN ANCHOR ON ONE SIDE OF VEHICLE, AROUND END OF BOTTOM LAYER OF CONTAINERS AS SHOWN, TO A TIEDOWN ANCHOR ON THE OPPOSITE SIDE OF THE VEHICLE.

**LOAD AS SHOWN**

ITEM	QUANTITY	WEIGHT (APPROX)
CONTAINER	15	1,440 LBS
PALLET UNIT	1	695 LBS
<b>TOTAL WEIGHT</b>		<b>2,135 LBS</b>

**LOAD AS SHOWN**

ITEM	QUANTITY	WEIGHT (APPROX)
CONTAINER	23	2,208 LBS
PALLET UNIT	2	1,390 LBS
TOTAL WEIGHT		3,598 LBS

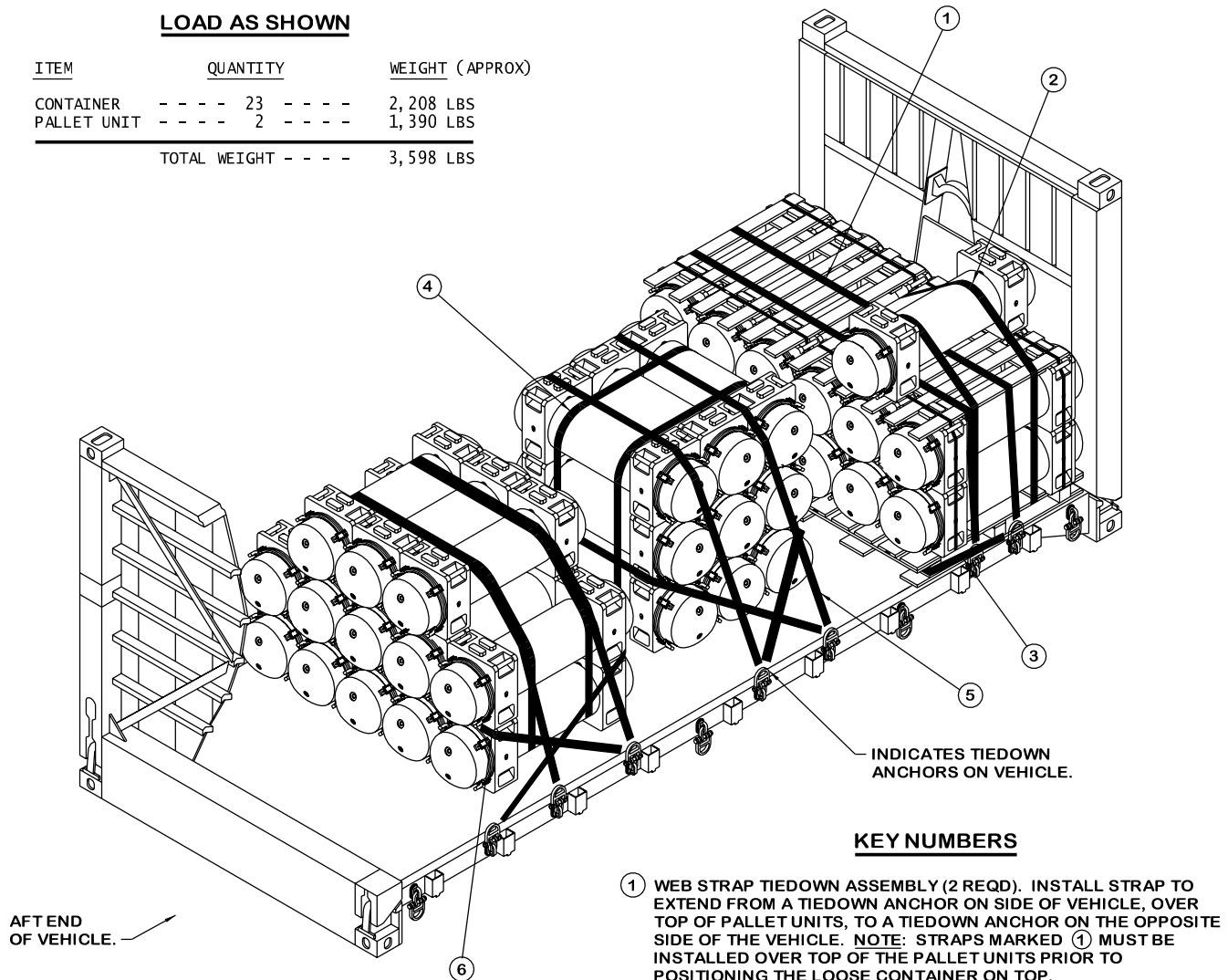

**ISOMETRIC VIEW**

**SPECIAL NOTES:**

1. A TYPICAL LOAD OF 23 LOOSE CONTAINERS AND TWO PALLET UNITS ARE SHOWN ON AN M1 PLS FLATRACK HAVING INSIDE DIMENSIONS OF 222" LONG BY 90" WIDE, AND A MAXIMUM TACTICAL LOAD WEIGHT OF 28,750 POUNDS.
2. THE PROCEDURES SHOWN ABOVE DEPICT METHODS OF SECURING PALLET UNITS AND/OR LOOSE CONTAINERS ON THE VEHICLE FLOOR AND/OR ON TOP OF A PALLET UNIT WHICH IS SECURED TO THE VEHICLE. HOLD DOWN STRAPS MARKED ① ARE POSITIONED OVER TOP OF THE PALLET UNITS AND MUST NOT BE POSITIONED OVER TOP OF LOOSE CONTAINER(S) ON TOP OF THE PALLET UNIT. SEE KEY NUMBERS ① AND ② AT RIGHT FOR GUIDANCE WHEN LOADING LOOSE CONTAINERS ON TOP OF A PALLET UNIT.
3. THE PALLET UNITS ARE POSITIONED AGAINST THE FORWARD ENDWALL AND ONE LOOSE CONTAINER IS POSITIONED ON TOP OF ONE OF THE PALLET UNITS. ONE BUNDLE OF NINE LOOSE CONTAINERS AND ONE BUNDLE OF 13 LOOSE CONTAINERS ARE POSITIONED ON THE VEHICLE FLOOR. IF THE PALLET UNITS ARE NOT POSITIONED AGAINST A FORWARD ENDWALL, ONE ADDITIONAL STRAP MARKED ③ IS REQUIRED AT THE FORWARD END. PIECE MARKED ⑥ MAY BE ELIMINATED ON ANY END FOR A BUNDLE THAT IS IN TIGHT CONTACT WITH ANOTHER BUNDLE OR ROW OF PALLET UNITS AT THAT END.
4. THE QUANTITY OF LOOSE CONTAINERS THAT CAN BE SECURED ON TOP OF A PALLET UNIT MAY BE ONE OR TWO CONTAINERS. ALL LOOSE CONTAINERS POSITIONED ON TOP OF A PALLET UNIT MUST BE SECURED TO THE PALLET UNIT WITH TWO UNITIZING STRAPS AS SHOWN.
5. A TOTAL OF 17 WEB STRAP TIEDOWN ASSEMBLIES ARE REQUIRED FOR THE LOAD SHOWN.

**KEY NUMBERS**

- ① WEB STRAP TIEDOWN ASSEMBLY (2 REQD). INSTALL STRAP TO EXTEND FROM A TIEDOWN ANCHOR ON SIDE OF VEHICLE, OVER TOP OF PALLET UNITS, TO A TIEDOWN ANCHOR ON THE OPPOSITE SIDE OF THE VEHICLE. NOTE: STRAPS MARKED ① MUST BE INSTALLED OVER TOP OF THE PALLET UNITS PRIOR TO POSITIONING THE LOOSE CONTAINER ON TOP.
- ② WEB STRAP TIEDOWN ASSEMBLY (2 REQD). POSITION LOOSE CONTAINER ON TOP OF PALLET UNIT. INSTALL EACH STRAP TO ENIRCLE THE PALLET UNIT AND LOOSE CONTAINER. THREAD STRAP UNDER DECK OF PALLET UNIT, BRING ENDS OF STRAPS UP OVER TOP OF LOOSE CONTAINER AND HOOK ENDS TOGETHER. NOTE: STRAPS MARKED ② MUST BE PRE-POSITIONED AROUND THE FIRST PALLET UNIT PRIOR TO LOADING THE SECOND PALLET UNIT AND PRIOR TO THE INSTALLATION OF PIECE MARKED ①.
- ③ WEB STRAP TIEDOWN ASSEMBLY (1 REQD). INSTALL STRAP TO EXTEND FROM A TIEDOWN ANCHOR ON ONE SIDE OF VEHICLE, AROUND WOODEN PALLET AS SHOWN, TO A TIEDOWN ANCHOR ON THE OPPOSITE SIDE OF THE VEHICLE.
- ④ WEB STRAP TIEDOWN ASSEMBLY (4 REQD, 2 FOR EACH BUNDLE). INSTALL EACH STRAP TO ENIRCLE ALL CONTAINERS IN THE BUNDLE. PRE-POSITION THESE STRAPS ON THE FLOOR OF THE VEHICLE, AT THE PROPER LOCATIONS, PRIOR TO LOADING CONTAINERS. MAKE SURE STRAPS LAY FLAT ACROSS THE FLOOR. AFTER ALL CONTAINERS ARE STACKED, BRING ENDS OF STRAPS UP OVER TOP OF STACK, HOOK ENDS OF STRAPS TOGETHER. THE RATCHETS MAY BE POSITIONED ANYWHERE ACROSS THE TOP OF THE STACK OR SINGLE LAYER ROW.
- ⑤ WEB STRAP TIEDOWN ASSEMBLY (4 REQD). INSTALL EACH STRAP TO EXTEND FROM A TIEDOWN ANCHOR ON SIDE OF VEHICLE, OVER TOP OF BUNDLE, TO A TIEDOWN ANCHOR ON THE OPPOSITE SIDE OF THE VEHICLE. POSITION THE STRAPS STRAIGHT ACROSS THE BUNDLE IF POSSIBLE, HOWEVER, DUE TO THE LOCATION AND QUANTITY OF TIEDOWN ANCHORS, IT MAY BE NECESSARY TO POSITION THESE STRAPS DIAGONALLY ACROSS THE BUNDLE.
- ⑥ WEB STRAP TIEDOWN ASSEMBLY (4 REQD). INSTALL STRAP TO EXTEND FROM A TIEDOWN ANCHOR ON ONE SIDE OF VEHICLE, AROUND END OF BOTTOM LAYER OF CONTAINERS AS SHOWN, TO A TIEDOWN ANCHOR ON THE OPPOSITE SIDE OF THE VEHICLE.

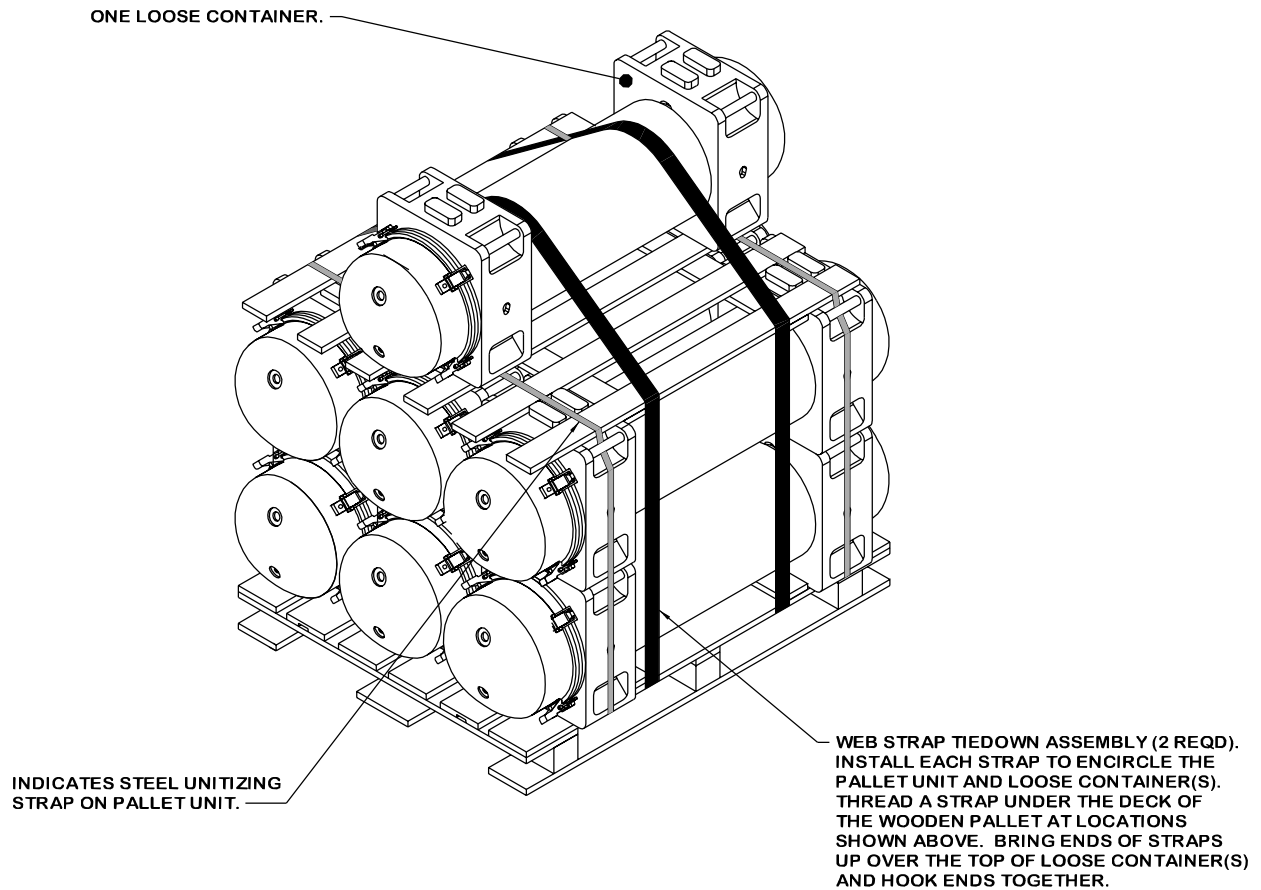

**SECUREMENT OF LOOSE CONTAINERS ON TOP OF A FULL PALLET UNIT**

ONE OR TWO LOOSE CONTAINERS MAY BE SECURED ON TOP OF A PALLET UNIT.

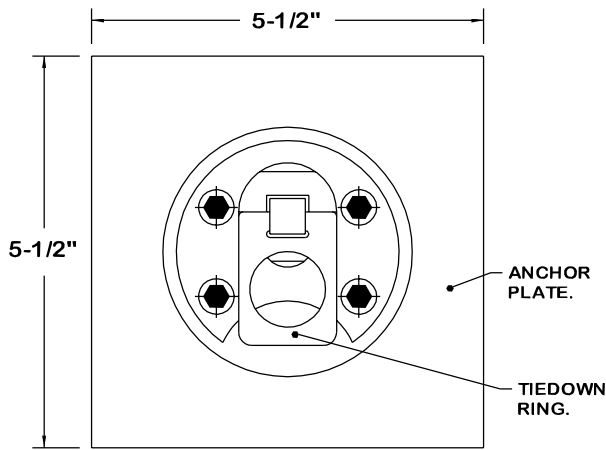

**UNIVERSAL TIEDOWN ANCHOR (FRONT VIEW)**

SEE SPECIAL NOTE 1.

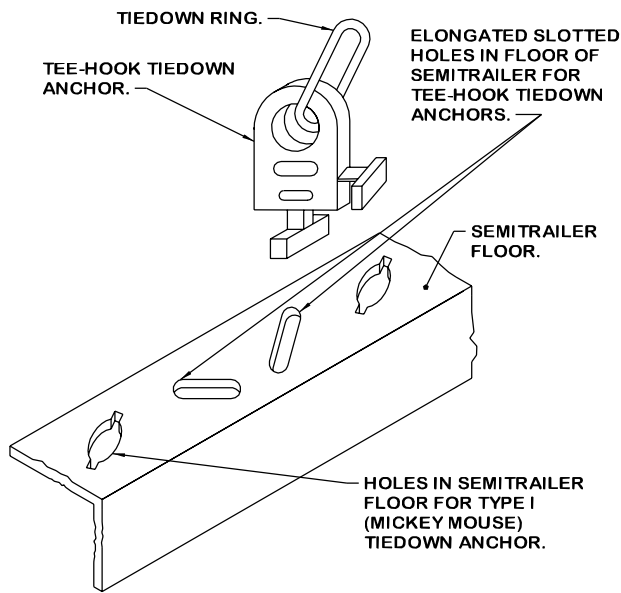

**TEE-HOOK TIEDOWN ANCHOR (ISOMETRIC VIEW)**

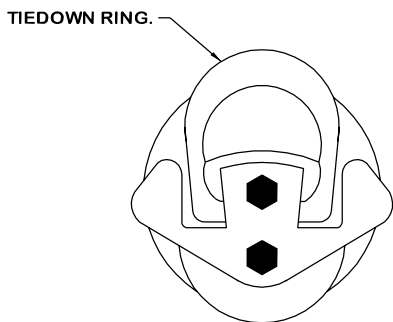

**REMOVABLE TIEDOWN ANCHOR (TOP VIEW)**

SEE SPECIAL NOTE 3.

**SPECIAL NOTES:**

1. IF THE TACTICAL VEHICLES BEING USED ARE NOT EQUIPPED WITH THE 5,000 POUND UNIVERSAL TIEDOWN ANCHOR SHOWN AT LEFT, SEE TB 9-2300-280-30 FOR VEHICLE MODIFICATION PROCEDURES AND INSTALLATION OF THE TIEDOWN ANCHOR. WITH THE EXCEPTION OF THE HEAVY EXPANDED MOBILITY TACTICAL TRUCK (HEMTT), M977 AND/OR M985, WHICH HAS THE TIEDOWN ANCHORS INSTALLED IN THE FLOOR, THESE TIEDOWN ANCHORS ARE TO BE INSTALLED IN THE SIDEWALLS AND ENDWALLS OF CARGO TRUCKS AND CARGO TRAILERS. IF AN M127, 12-TON SEMITRAILER IS BEING USED, SEE INFORMATION IN TB 9-2300-280-30. THE M127 SEMITRAILER REQUIRES A DIFFERENT TYPE OF TIEDOWN ANCHOR.
2. THIS TIEDOWN ANCHOR IS RATED AT 5,000 POUNDS AND IS ONLY INSTALLED ON THE M872 SEMITRAILER. THERE ARE FIVE TIEDOWN ANCHOR LOCATIONS ON EACH SIDE OF THE M872 SEMITRAILER. THIS TIEDOWN ANCHOR IS POSITIONED BY INSERTING IT FROM THE TOP INTO ONE OF THE ELONGATED SLOTTED HOLES LOCATED ON THE SIDE OF THE SEMITRAILER FLOOR. THIS TIEDOWN ANCHOR IS FURTHER IDENTIFIED AS NSN 2540-01-113-9285.
3. THIS TIEDOWN ANCHOR IS RATED AT 10,000 POUNDS AND IS INSTALLED ON THE M871 AND M872 SEMITRAILERS. IT IS COMMONLY REFERRED TO AS "MICKEY MOUSE". THERE ARE TEN TIEDOWN ANCHOR LOCATIONS ON EACH SIDE OF THE M871 SEMITRAILER AND APPROXIMATELY TWENTY-EIGHT ON EACH SIDE OF THE M872 SEMITRAILER. THIS TIEDOWN ANCHOR IS POSITIONED BY REACHING UNDER THE FLOOR OF THE SEMITRAILER, INSERTING IT UP THROUGH THE HOLE AND ROTATING IT INTO POSITION. THIS TIEDOWN ANCHOR IS FURTHER IDENTIFIED AS NSN 2540-01-112-1732.
4. THIS TIEDOWN ANCHOR IS RATED AT 10,000 POUNDS AND IS ONLY FOR USE ON THE M871 SEMITRAILER. IT IS COMMONLY REFERRED TO AS "BIG FOOT". THERE ARE TEN TIEDOWN ANCHOR LOCATIONS ON EACH SIDE OF THE SEMITRAILER. IT HAS A SPRING/LOADED LOCKING DEVICE TO HOLD IT IN PLACE, IS INSERTED FROM THE TOP INTO A 1-3/4" DIAMETER HOLE LOCATED ON THE SIDE OF THE SEMITRAILER FLOOR, AND IT SWIVELS. THIS TIEDOWN IS FURTHER IDENTIFIED AS NSN 2540-01-117-3043.
5. THIS TIEDOWN ANCHOR IS RATED AT 10,000 POUNDS, IS NOT REMOVABLE AND IS ONLY INSTALLED ON THE M871 SEMITRAILER. THERE ARE FIVE ON EACH SIDE OF THE M871 SEMITRAILER AND THEY DO NOT SWIVEL.

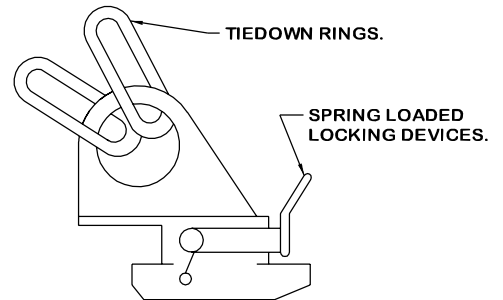

**REMOVABLE TIEDOWN ANCHOR (SIDE VIEW)**

SEE SPECIAL NOTE 4.

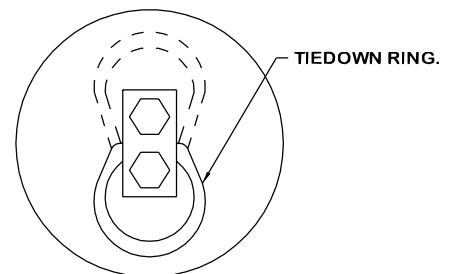

**FIXED TIEDOWN ANCHOR (TOP VIEW)**

SEE SPECIAL NOTE 5.

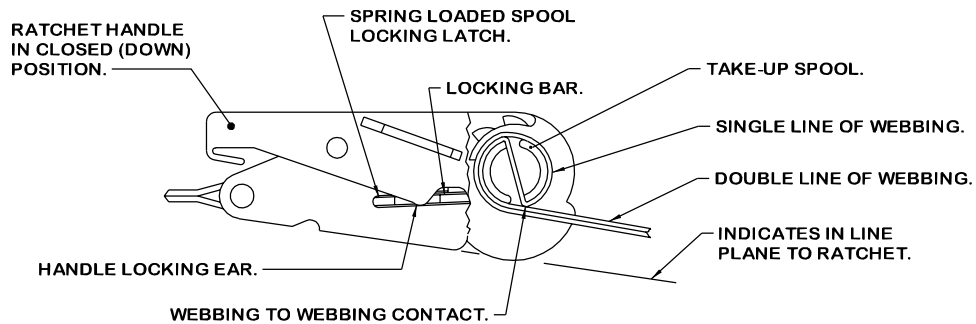

**STEP 1**

IN THIS VIEW PART OF THE RATCHET HOUSING IS SHOWN BROKEN AWAY TO DEPICT WEBBING-TO-WEBBING CONTACT ON THE TAKE-UP SPOOL OF THE RATCHET. WEBBING-TO-WEBBING CONTACT IS ACHIEVED WHEN THE OPERATOR HOLDS THE DOUBLE LINE OF WEBBING IN AN "IN LINE PLANE TO THE RATCHET" AND IT MAKES CONTACT WITH THE SINGLE LINE OF WEBBING.

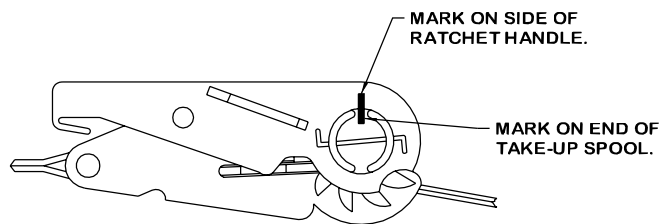

THIS VIEW DEPICTS THE LOCATION OF THE FIXED MARK ON THE RATCHETING HANDLE, WITH ANOTHER MATCHING MARK ON THE TAKE-UP SPOOL, AFTER WEBBING-TO-WEBBING CONTACT HAS BEEN MADE.

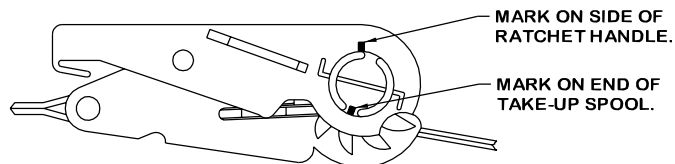

**STEP 3**

THIS VIEW DEPICTS THE LOCATION OF THE MARK ON THE END OF THE TAKE-UP SPOOL AFTER THE SPOOL HAS BEEN ROTATED ONE-HALF TURN, AFTER WEBBING-TO-WEBBING CONTACT HAS BEEN MADE.

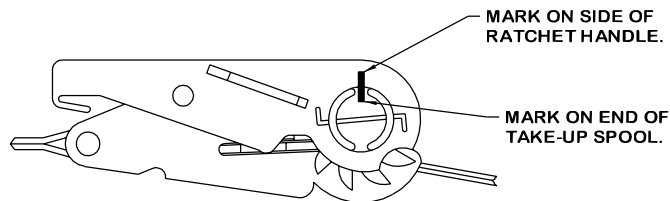

**STEP 4**

THIS VIEW DEPICTS THE LOCATION OF THE MARK ON THE END OF THE TAKE-UP SPOOL AFTER THE SPOOL HAS BEEN ROTATED ONE FULL TURN, AFTER WEBBING-TO-WEBBING CONTACT HAS BEEN MADE.



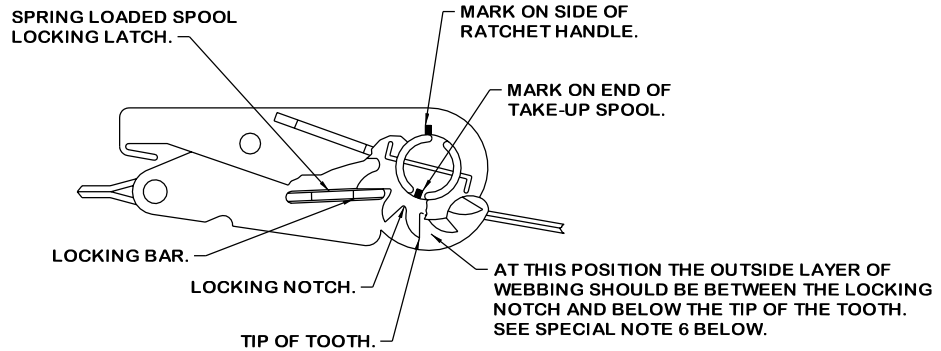

### STEP 5

THIS VIEW DEPICTS THE LOCATION OF THE MARK ON THE END OF THE TAKE-UP SPOOL AFTER THE SPOOL HAS BEEN ROTATED ONE AND ONE-HALF TURNS, AFTER WEBBING-TO-WEBBING CONTACT HAS BEEN MADE. ALSO IN THIS VIEW, PART OF THE RATCHET HANDLE IS BROKEN AWAY TO SHOW THE LOCKING BAR FULLY SEATED IN THE MATCHING LOCKING NOTCH (SPROCKET GEAR TEETH).

#### SPECIAL NOTES:

1. THE PURPOSE OF THE RATCHET DETAILS ON PAGE 24 AND THE DETAIL AND NOTES ON THIS PAGE ARE TO AUGMENT THE GUIDANCE SET FORTH WITHIN GENERAL NOTE "G" ON PAGE 2.
2. THE REQUIREMENTS FOR 1/2 BUT NOT MORE THAN 1-1/2 WRAPS OF STRAP ON THE TAKE-UP SPOOL OF THE TENSIONING RATCHET, AS SPECIFIED WITHIN GENERAL NOTE "O" ON PAGE 2, ACTUALLY MEANS 1/2 TO 1-1/2 WRAPS OF DOUBLE WEBBING, THE 1/2 TO 1-1/2 TURNS. ALSO, THE 1/2 TO 1-1/2 WRAPS (TURNS) ARE TO BE ACCOMPLISHED ONLY AFTER ENOUGH WEBBING HAS BEEN WOUND ONTO THE SPOOL TO ACHIEVE A WEBBING-TO-WEBBING CONFIGURATION, AS SHOWN IN THE "STEP 1" DETAIL ON PAGE 24.
3. ONE METHOD THAT CAN BE USED TO ENSURE THAT THE 1/2 TO 1-1/2 WRAPS ARE WOUND ONTO THE TAKE-UP SPOOL, AFTER WEBBING-TO-WEBBING CONTACT HAS BEEN MADE, IS TO PLACE A FIXED MARK (PAINT OR SIMILAR MATERIAL) ON THE SIDE OF THE RATCHETING HANDLE, WITH THE HANDLE IN ITS CLOSED (DOWN) POSITION, AND ANOTHER SHORT MATCHING MARK ON THE END OF THE SPOOL, AS SHOWN IN THE "STEP 2" DETAIL ON PAGE 24. AS THE SPOOL IS ROTATED TO TENSION A TIEDOWN STRAP ASSEMBLY, THE NUMBER OF WRAPS (TURNS) CAN BE DETERMINED VISUALLY BY COMPARING THE "MARK" LOCATION ON THE SPOOL TO THE "MARK" LOCATION ON THE RATCHETING HANDLE WITH THE HANDLE IN CLOSED POSITION. SEE THE "STEP 3" AND "STEP 4" DETAILS ON PAGE 24, AND "STEP 5" ABOVE.
4. ANOTHER METHOD THAT CAN BE USED TO ENSURE THAT THE 1/2 TO 1-1/2 WRAPS ARE ACHIEVED, AFTER WEBBING-TO-WEBBING CONTACT HAS BEEN MADE, IS TO COUNT THE AUDIBLE CLICKS MADE BY THE RATCHET ASSEMBLY AS A WEB STRAP ASSEMBLY IS BEING TENSIONED. THE RATCHET ASSEMBLY ON MOST WEB STRAP ASSEMBLIES HAVE 11 TEETH ON THE GEARLIKE DEVICE ON EACH END OF THE TAKE-UP SPOOL; SOME OTHER STRAP ASSEMBLIES HAVE ONLY 9 TEETH. THEREFORE, AFTER INITIAL WEBBING-TO-WEBBING CONTACT HAS BEEN MADE, ROTATE (TURN) THE SPOOL THROUGH A MINIMUM OF 6 TO A MAXIMUM OF 17 CLICKS (1/2 TO 1-1/2 WRAPS) WHEN THE GEAR HAS 11 TEETH, AND ROTATE (TURN) THE SPOOL THROUGH A MINIMUM OF 5 TO A MAXIMUM OF 14 CLICKS (1/2 TO 1-1/2 WRAPS) IF THE GEAR HAS 9 TEETH.

(CONTINUED AT RIGHT)

#### (SPECIAL NOTES CONTINUED)

5. AFTER A STRAP ASSEMBLY HAS BEEN PROPERLY TENSIONED, CARE MUST BE EXERCISED TO ASSURE THAT THE TAKE-UP SPOOL LOCKING LATCH (SPRING LOADED DEVICE WITH A LOCKING BAR ON EACH SIDE OF THE RATCHET ASSEMBLY) IS FULLY SEATED ON BOTH SIDES IN MATCHING LOCKING NOTCHES, WHICH ARE SIMILAR TO SPROCKET GEAR TEETH, THAT ARE LOCATED ON EACH END OF THE TAKE-UP SPOOL. SEE "STEP 5" DETAIL ABOVE. THE LOCKING LATCH IS "FULLY SEATED" WHEN THE HANDLE WILL CLOSE AND THE LOCKING EAR, OR SIMILAR DEVICE ON THE HANDLE, PREVENTS THE ACCIDENTAL WITHDRAWAL OF THE LOCKING LATCH. SEE "STEP 1" DETAIL ON PAGE 24. IF THE FULLY SEATED CONDITION CANNOT BE ACHIEVED, THE STRAP MUST BE RELEASED AND HAND RETENSIONED AS TIGHT AS POSSIBLE TO ACHIEVE THE FULLY SEATED CONDITION.
6. ANOTHER VISUAL METHOD OF DETERMINING WHEN THERE IS 1/2 TO 1-1/2 WRAPS OF WEBBING ON THE TAKE-UP SPOOL, AFTER INITIAL WEBBING-TO-WEBBING CONTACT HAS BEEN MADE, IS TO LOOK AT THE SPOOL. WHEN A TIEDOWN IS COMPLETE, THE STRAP WEBBING ON THE SPOOL OF THE RATCHET SHOULD BE ABOVE THE LOWER CURVE OF THE LOCKING NOTCH, AND SHOULD BE BELOW THE TIPS OF THE TEETH OF THE RATCHET AS IDENTIFIED IN "STEP 5" ABOVE. IT SHOULD BE NOTED THAT ANY PROCEDURES THAT ENSURE PROPER TENSIONING ARE ACCEPTABLE AND METHODS ON THE DRAWING ONLY PROVIDE SOME METHODS.

## LOAD PLANNING GUIDANCE CHART

WHEN TRANSPORTING PALLET UNITS AND/OR CONTAINERS ON TACTICAL VEHICLES, USE THE FOLLOWING CHART FOR LOAD PLANNING GUIDANCE. ALL THE VEHICLES LISTED IN THE CHART ARE NOT SHOWN IN THIS DOCUMENT. OTHER TYPES OF VEHICLES NOT LISTED IN THIS CHART MAY BE USED AS LONG AS THEY COMPLY WITH GENERAL NOTE "G" ON PAGE 2. SEE NOTES AT RIGHT.

### LOAD PLANNING NOTES:

1. DETERMINE THE QUANTITY OF PALLET UNITS AND/OR LOOSE CONTAINERS TO BE LOADED IN/ON THE TACTICAL VEHICLE.
2. SELECT THE BEST METHOD OF SECURING THE UNIT(S) AND/OR LOOSE CONTAINER(S) FROM THE METHODS SHOWN ON THE REFERENCED PAGES. NOTE: A COMBINATION OF METHODS MAY BE USED IN/ON THE SAME TACTICAL VEHICLE.

TACTICAL VEHICLE			JAVELIN MISSILE	
			PALLET SEE PAGE(S)	CONTAINER SEE PAGE(S)
M1	FLATRACK	14-3/8 TON	6 - 15	18 - 21
M34	CARGO TRUCK	2-1/2 TON	6 - 11	18 - 19
M35	CARGO TRUCK	2-1/2 TON	6 - 11	18 - 19
M36/M36C	CARGO TRUCK	2-1/2 TON	6 - 11, 13	18 - 20
M37	CARGO TRUCK	3/4 TON	6 - 8	18 - 19
M41	CARGO TRUCK	5 TON	6 - 11	18 - 20
M47	DUMP TRUCK	2-1/2 TON	6 - 9	18 - 19
M51	DUMP TRUCK	5 TON	6 - 9	18 - 19
M54	CARGO TRUCK	5 TON	6 - 11	18 - 20
M55	CARGO TRUCK	5 TON	6 - 15	18 - 21
M59	DUMP TRUCK	2-1/2 TON	6 - 9	18 - 19
M100	CARGO TRAILER	1/4 TON	NONE	18
M101	CARGO TRAILER	3/4 TON	6 - 9	18 - 19
M105	CARGO TRAILER	1-1/2 TON	6 - 9	18 - 19
M125	CARGO TRUCK	10 TON	6 - 11	18 - 20
M127	SEMITRAILER	12 TON	6 - 17	18 - 21
M135	CARGO TRUCK	2-1/2 TON	6 - 11	18 - 19
M211	CARGO TRUCK	2-1/2 TON	6 - 11	18 - 19
M215	DUMP TRUCK	2-1/2 TON	6 - 9	18 - 19
M332	AMMO TRAILER	1-1/2 TON	6 - 8	18 - 19
M342	DUMP TRUCK	2-1/2 TON	6 - 9	18 - 19
M520	CARGO TRUCK	8 TON	6 - 11, 13	18 - 20
M548	CARGO CARRIER	6 TON	6 - 9	18 - 19
M561	CARGO TRUCK	1-1/4 TON	6 - 8	18 - 19
M602	CARGO TRUCK	2-1/2 TON	6 - 11	18 - 19
M656	CARGO TRUCK	5 TON	6 - 11	18 - 20
M715	CARGO TRUCK	1-1/4 TON	6 - 9	18 - 19
M813	CARGO TRUCK	5 TON	6 - 11	18 - 20
M814	CARGO TRUCK	5 TON	6 - 11	18 - 20
M817	DUMP TRUCK	5 TON	6 - 9	18 - 19
M871	SEMITRAILER	22-1/2 TON	6 - 16	18 - 21
M872	SEMITRAILER	34 TON	6 - 17	18 - 21
M925A1	CARGO TRUCK	5 TON	6 - 11	18 - 20
M927A1	CARGO TRUCK	5 TON	6 - 15	18 - 21
M939 (SWB)	CARGO TRUCK	5 TON	6 - 11	18 - 20
M939 (LWB)	CARGO TRUCK	5 TON	6 - 15	18 - 21
M977/M985	HEMTT	10 TON	6 - 11, 13	18 - 21
M989A1	HEMAT	11 TON	6 - 11	18 - 20
M998	HMMWV	1-1/4 TON	6 - 8	18 - 19
M1008	CUCV	1-1/4 TON	6 - 9	18 - 19
M1077	FLATRACK	16-1/2 TON	6 - 15	18 - 21
M1078	CARGO TRUCK	2-1/2 TON	6 - 11	18 - 19
M1083	CARGO TRUCK	5 TON	6 - 11	18 - 20
M1084	CARGO TRUCK	5 TON	6 - 11	18 - 20
M1085	CARGO TRUCK	5 TON	6 - 15	18 - 21
M1086	CARGO TRUCK	5 TON	6 - 15	18 - 21
M1102	HMT	1-1/4 TON	6 - 8	18 - 19