

# AADCP

## LOADING AND BRACING ON EUROPEAN RAILCAR OF AN/TSQ-73 SYSTEM SUPPORT EQUIPMENT, MOUNTED ON A 5-TON CARGO TRUCK, M814

 DELINEATED LOADING AND BRACING PROCEDURES COMPLY WITH THE REQUIREMENTS OF APPENDIX C TO TM 55-601.

NOTICE: DEPICTED LOAD IS OVERSIZE, MOVEMENT MUST BE COORDINATED WITH DB OR SNCB.

U.S. ARMY MATERIEL COMMAND DRAWING			
APPROVED, U.S. ARMY MISSILE COMMAND  <i>Paul W. Honea</i>	DRAFTSMAN B. KUNDERT	TECHNICIAN R. HAYNES	ENGINEER D. WILLIS
APPROVED BY ORDER OF COMMANDING GENERAL, U.S. ARMY MATERIEL COMMAND  <i>William F. Ernst</i>	VALIDATION ENGINEERING DIVISION <i>JFK</i>	TRANSPORTATION ENGINEERING DIVISION <i>W. Frensch</i>	LOGISTICS ENGINEERING OFFICE <i>W F Ernst</i>
AUGUST 1992			
	CLASS	DIVISION	DRAWING
	19	48	7845
	FILE		GSE5A08

NOT NECESSARILY  
DRAWN TO SCALE

**GENERAL NOTES**

- A. THIS DOCUMENT HAS BEEN PREPARED AND ISSUED IN ACCORDANCE WITH AR 740-1.
- B. THE OUTLOADING PROCEDURES SHOWN HEREIN ARE APPLICABLE TO EUROPEAN RAILCARS WHICH CONFORM TO THE RIV REQUIREMENTS.
- C. THE LOAD AS SHOWN IS BASED ON RIV RAILCARS (KBS 442/443 AND KLS 442/443) 41'-0-1/8" (12,500 MM) LONG BY 9'-1-3/64" (2,770 MM) WIDE WITH 18" (457 MM) CAR SIDES. ADDITIONAL UNITS OR OTHER ITEMS MAY BE LOADED ON THE CAR, WITH THE VIEW TOWARD FULL UTILIZATION OF CARRIER EQUIPMENT.
- D. LADING DATA:  
 ITEM DIMENSIONS ----- 32'-2" (9,804 MM) LONG BY 8'-2" (2,489 MM) WIDE BY 9'-10" (2,997 MM) HIGH.  
 ITEM GROSS WEIGHT ----- 32,840 POUNDS (14,896 KG) (APPROX).
- E. A LIST OF RAILCARS THAT MAY BE USED FOR SHIPMENTS OF THE DEPICTED LOAD IS SHOWN IN THE CHART ON THIS PAGE. OTHER TYPES OF RAILCARS CAN BE USED PROVIDING THESE OTHER CARS ARE PROPERLY EQUIPPED FOR THE APPLICATION OF THE PRESCRIBED LOAD-SECURING BLOCKING IN ACCORDANCE WITH THE SPECIFIED PROCEDURES. MINOR DEVIATIONS FROM THE LOCATIONS SHOWN IN THE LOAD VIEWS FOR INSTALLING BLOCKING AND TIE DOWN COMPONENTS ON A CAR ARE PERMITTED. HOWEVER, THE INTENT OF THE SPECIFIED BLOCKING PROCEDURES MUST BE ACHIEVED.
- F. REMOVE ALL POSTS FROM SIDE OF CAR AND PLACE IN RACKS UNDER CAR, IF APPLICABLE.
- G. THE NUMBER OF UNITS MAY BE ADJUSTED TO FIT THE RAILCAR CONCERNED, OR THE QUANTITY TO BE SHIPPED; HOWEVER, THE APPROVED METHODS CONTAINED HEREIN, FOR FULL OR PARTIAL CARLOAD, MUST BE FOLLOWED FOR BLOCKING, BRACING, AND STAYING OF THIS ITEM.
- H. NOTICE: A STAGGERED NAILING PATTERN WILL BE USED WHEREVER POSSIBLE WHEN NAILS ARE DRIVEN INTO JOINTS OF DUNNAGE ASSEMBLIES. ALSO, A STAGGERED NAILING PATTERN WILL BE USED WHEN DUNNAGE IS NAILED TO THE FLOOR OF THE RAILCAR, OR WHEN LAMINATING DUNNAGE. THE NAILING PATTERN WILL BE ADJUSTED AS REQUIRED SO THAT A NAIL DOES NOT PENETRATE INTO OR NEAR A CRACK BETWEEN FLOOR BOARDS. ADDITIONALLY, THE NAILING PATTERN FOR AN UPPER PIECE OF LAMINATED DUNNAGE WILL BE ADJUSTED AS REQUIRED SO THAT A NAIL FOR THAT PIECE WILL NOT BE DRIVEN THROUGH ONTO OR RIGHT BESIDE A NAIL IN A LOWER PIECE.
- J. NAILS USED FOR FLOOR LINE BLOCKING WILL HAVE A MINIMUM DIAMETER OF 5 MM. NAIL SIZES WILL BE SELECTED TO PROVIDE A MINIMUM OF 40MM PENETRATION INTO THE CAR FLOOR. HOWEVER, THE LENGTH OF THE NAIL WILL BE SUCH THAT THE NAIL DOES NOT COMPLETELY PENETRATE THE CAR FLOOR. SEE THE "NAIL CHART" AT THE RIGHT AND THE "TYPICAL NAILING OF FLOOR LINE BLOCKING TO CAR FLOOR" DETAIL ON PAGE 3. NAILS WHICH ARE OF OTHER SIZES OR WHICH HAVE A NOMENCLATURE DIFFERENT THAN THAT USED HEREIN, MAY ALSO BE USED PROVIDED THEY MEET THE MINIMUM REQUIREMENTS STIPULATED WITHIN THIS DOCUMENT.
- K. CAUTION: DURING WIRE ROPE INSTALLATION AVOID ALL CONTACT WITH ELECTRICAL WIRING, VEHICLE CONTROLS AND OTHER APPURTENANCES.
- L. FIVE-EIGHTH INCH (5/8") STEEL WIRE ROPE IS SPECIFIED WHERE REQUIRED FOR TIEDOWNS TO SECURE THE ITEM. IF DESIRED, OR IF 5/8" STEEL WIRE ROPE IS NOT AVAILABLE, STEEL WIRE ROPE OF A LARGER DIAMETER MAY BE USED. WIRE ROPE CABLE MUST BE TENSIONED SUFFICIENTLY TO CAUSE SLIGHT VEHICLE BODY DEPRESSION. TENSIONING CAN BE ACCOMPLISHED BY EMPLOYING TWO (2) CABLE "GRIPPERS" AND AN APPLICABLE SIZED "COME-A-LONG" TYPE MECHANICAL HOIST.
- M. ALL HAND BRAKES MUST BE "SET" WITH THE HAND LEVERS WIRE TIED OR BLOCKED, AND TIRES WILL BE INFLATED TO 10 PSI ABOVE REGULAR OPERATING PRESSURE.
- N. THE PROCEDURES DEPICTED WITHIN THIS DRAWING ARE BASED ON THE USE OF DIMENSIONAL SIZED LUMBER. IN MOST CASES THE METRIC EQUIVALENT IS GIVEN IN PARENTHESIS FOLLOWING THE DIMENSION. HOWEVER, WHERE THE METRIC EQUIVALENT IS NOT SHOWN, IT MAY BE COMPUTED BY USING 1" EQUALS 25.4 MM. METRIC EQUIVALENTS FOR WEIGHTS ARE BASED ON 1 LB EQUALS 0.454 KG. METRIC EQUIVALENTS FOR TORQUE ARE BASED ON 1 FOOT-POUND EQUALS 0.7376 NEWTON-METERS.

LIST OF RAILCARS THAT MAY BE USED FOR SHIPMENTS			
TYPE OF RAILCAR	LENGTH OF RAILCAR	NO. OF ITEMS	MAXIMUM TOTAL WEIGHT (APPROX) OF ITEMS
KLMS 440	34'-11-11/16" (10,660 MM)	1	32,840 LBS (14,896 KG)
KLM 506	34'-8-1/2" (10,580 MM)	1	32,840 LBS (14,896 KG)
KBS 442/443	41'-0-1/8" (12,500 MM)	1	32,840 LBS (14,896 KG)
KLS 442/443	41'-0-1/8" (12,500 MM)	1	32,840 LBS (14,896 KG)
RMMS 663/664	41'-5-51/64" (12,644 MM)	1	32,840 LBS (14,896 KG)
RS 680/681	60'-8-23/64" (18,500 MM)	1	32,840 LBS (14,896 KG)
RS 683/684	60'-8-23/64" (18,500 MM)	1	32,840 LBS (14,896 KG)
SAS 710	49'-2-9/16" (15,000 MM)	1	32,840 LBS (14,896 KG)

**MATERIAL SPECIFICATIONS**

- LUMBER** ----- DOUGLAS FIR OR COMPARABLE LUMBER WITH STRAIGHT GRAIN AND FREE FROM MATERIAL DEFECTS. REF: FED SPEC MM-L-751.
- NAILS** ----- COMMON. REF: FED SPEC FF-N-105.
- ROPE** ----- STEEL WIRE, PLAIN, PREFORMED, REGULAR LAY. REF: FED SPEC RR-W-410.
- CLIP** ----- "U" BOLT, CROSBY, HEAVY DUTY (OR EQUAL). REF: FED SPEC FF-C-450, TYPE 1, CLASS 1.
- ANTI-CHAFING MATERIAL** ----- NEUTRAL BARRIER MATERIAL, MIL-B-121 (OR EQUAL).

NAIL CHART			
SIZE	LENGTH	DIAMETER	
10d	3" ( 76 MM )	0.1483"	( 3.77 MM )
12d	3-1/4" ( 83 MM )	0.1483"	( 3.77 MM )
16d	3-1/2" ( 89 MM )	0.1620"	( 4.11 MM )
20d	4" ( 102 MM )	0.1920"	( 4.88 MM )
30d *	4-1/2" ( 114 MM )	0.2070"	( 5.26 MM )
40d *	5" ( 127 MM )	0.2253"	( 5.72 MM )
50d *	5-1/2" ( 140 MM )	0.2437"	( 6.19 MM )
60d *	6" ( 152 MM )	0.2625"	( 6.67 MM )

\* NAILS WHICH HAVE ADEQUATE DIAMETER FOR NAILING FLOOR LINE BLOCKING. THE LENGTH OF THE NAIL MUST MEET THE REQUIREMENTS OF GENERAL NOTE "J".

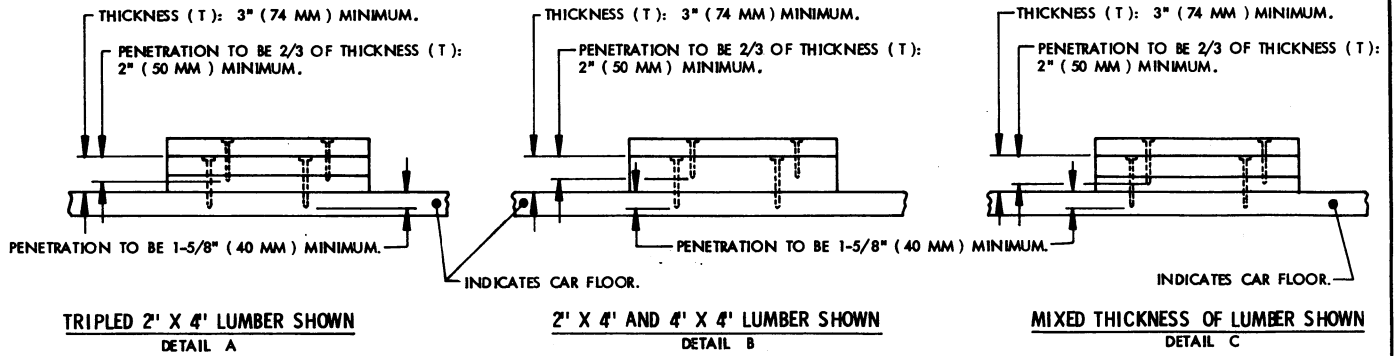

TYPICAL NAILING OF FLOOR LINE BLOCKING TO CAR FLOOR

SPECIAL NOTES:

1. THE DETAILS ON THIS PAGE DEPICT POSSIBLE VARIATIONS THAT MAY RESULT FROM USING AVAILABLE LUMBER FOR FLOOR LINE BLOCKING. KEY NUMBERS THROUGHOUT THIS DOCUMENT SPECIFY TRIPLED PIECES OF LUMBER WHICH ARE 2" X 4" IN SIZE FOR SIDE BLOCKING, AS SHOWN IN DETAIL A ABOVE. IT IS PERMISSABLE TO USE MIXED THICKNESSES OF LUMBER AS TYPICALLY SHOWN IN DETAILS B AND C, IN LIEU OF THE SPECIFIED TRIPLED 2" X 4" LUMBER. THE INTENT OF THE SPECIFIED BLOCKING PROCEDURE MUST BE OBTAINED.
2. THE NUMBER OF NAILS USED TO SECURE EACH PIECE OF BLOCKING WILL BE SPECIFIED IN THE KEY NUMBERS FOR EACH SPECIFIC PROCEDURE. THE LENGTH OF THE NAILS SELECTED WILL BE ADEQUATE TO NAIL THROUGH THE BLOCKING AND ACHIEVE THE PENETRATION OF THE CAR FLOOR AS SPECIFIED. WHEN NAILING FLOOR LINE BLOCKING TO THE CAR FLOOR, AS DEPICTED IN DETAILS A, B, AND C, THE FOLLOWING APPLIES:

THICKNESS ( T ) OF BLOCKING		SIZE OF NAIL	
MINIMUM	MAXIMUM		
3" ( 74 MM )	3" ( 74 MM )	30d ( 4-1/2" )	( 114 MM )
3" ( 74 MM )	3-3/8" ( 87 MM )	40d ( 5" )	( 127 MM )
3-3/8" ( 87 MM )	4" ( 100 MM )	50d ( 5-1/2" )	( 140 MM )
4" ( 100 MM )	4-3/8" ( 112 MM )	60d ( 6" )	( 152 MM )

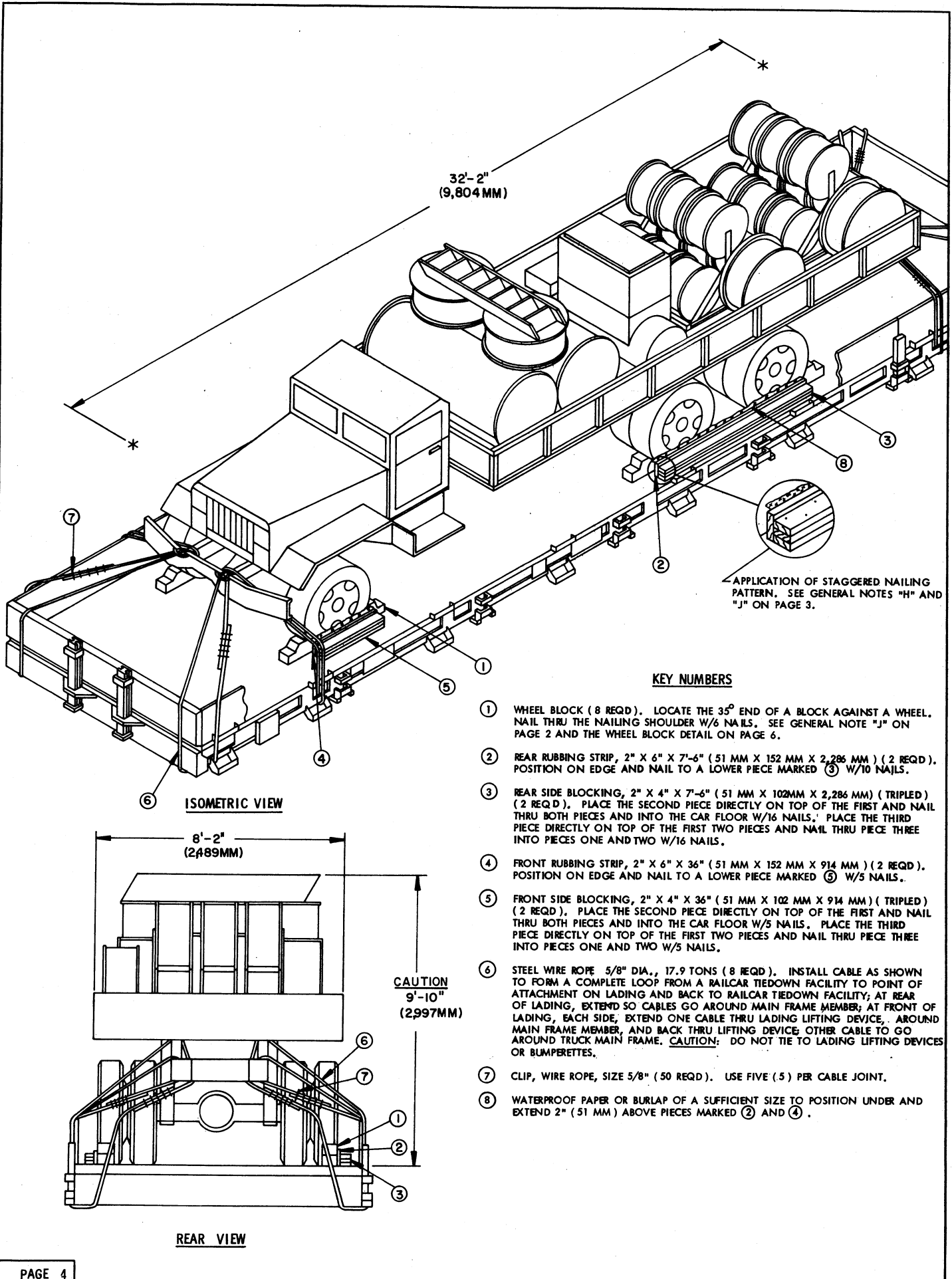

32'-2"  
(9,804 MM)

ISOMETRIC VIEW

8'-2"  
(2,489 MM)

REAR VIEW

CAUTION  
9'-10"  
(2,997 MM)

APPLICATION OF STAGGERED NAILING PATTERN. SEE GENERAL NOTES "H" AND "J" ON PAGE 3.

**KEY NUMBERS**

- ① WHEEL BLOCK (8 REQD). LOCATE THE 35° END OF A BLOCK AGAINST A WHEEL. NAIL THRU THE NAILING SHOULDER W/6 NAILS. SEE GENERAL NOTE "J" ON PAGE 2 AND THE WHEEL BLOCK DETAIL ON PAGE 6.
- ② REAR RUBBING STRIP, 2" X 6" X 7'-6" (51 MM X 152 MM X 2,286 MM) (2 REQD). POSITION ON EDGE AND NAIL TO A LOWER PIECE MARKED ③ W/10 NAILS.
- ③ REAR SIDE BLOCKING, 2" X 4" X 7'-6" (51 MM X 102MM X 2,286 MM) (TRIPLED) (2 REQD). PLACE THE SECOND PIECE DIRECTLY ON TOP OF THE FIRST AND NAIL THRU BOTH PIECES AND INTO THE CAR FLOOR W/16 NAILS. PLACE THE THIRD PIECE DIRECTLY ON TOP OF THE FIRST TWO PIECES AND NAIL THRU PIECE THREE INTO PIECES ONE AND TWO W/16 NAILS.
- ④ FRONT RUBBING STRIP, 2" X 6" X 36" (51 MM X 152 MM X 914 MM) (2 REQD). POSITION ON EDGE AND NAIL TO A LOWER PIECE MARKED ⑤ W/5 NAILS.
- ⑤ FRONT SIDE BLOCKING, 2" X 4" X 36" (51 MM X 102 MM X 914 MM) (TRIPLED) (2 REQD). PLACE THE SECOND PIECE DIRECTLY ON TOP OF THE FIRST AND NAIL THRU BOTH PIECES AND INTO THE CAR FLOOR W/5 NAILS. PLACE THE THIRD PIECE DIRECTLY ON TOP OF THE FIRST TWO PIECES AND NAIL THRU PIECE THREE INTO PIECES ONE AND TWO W/5 NAILS.
- ⑥ STEEL WIRE ROPE 5/8" DIA., 17.9 TONS (8 REQD). INSTALL CABLE AS SHOWN TO FORM A COMPLETE LOOP FROM A RAILCAR TIEDOWN FACILITY TO POINT OF ATTACHMENT ON LADING AND BACK TO RAILCAR TIEDOWN FACILITY; AT REAR OF LADING, EXTEND SO CABLES GO AROUND MAIN FRAME MEMBER; AT FRONT OF LADING, EACH SIDE, EXTEND ONE CABLE THRU LADING LIFTING DEVICE, AROUND MAIN FRAME MEMBER, AND BACK THRU LIFTING DEVICE; OTHER CABLE TO GO AROUND TRUCK MAIN FRAME. CAUTION: DO NOT TIE TO LADING LIFTING DEVICES OR BUMPERETTES.
- ⑦ CLIP, WIRE ROPE, SIZE 5/8" (50 REQD). USE FIVE (5) PER CABLE JOINT.
- ⑧ WATERPROOF PAPER OR BURLAP OF A SUFFICIENT SIZE TO POSITION UNDER AND EXTEND 2" (51 MM) ABOVE PIECES MARKED ② AND ④.

**SPECIAL NOTES:**

1. A ONE UNIT LOAD IS SHOWN ON A 9'-1-3/64" ( 2,770 MM ) WIDE EUROPEAN RAILCAR. SEE GENERAL NOTE "E" ON PAGE 2.
2. STEEL WIRE ROPE WILL PASS THRU A RAILCAR TIEDOWN FACILITY, THRU AN ANCHOR AND ALSO AROUND THE FRAME ON THE LADING AS SHOWN AND BACK TOWARD THE RAILCAR TIEDOWN FACILITY TO FORM A COMPLETE LOOP. FIVE CLIPS WILL BE USED TO SECURE EACH CABLE JOINT. SEE THE "CABLE JOINT" DETAIL ON PAGE 6. TENSIONING OF THE STEEL WIRE ROPE CAN BE ACCOMPLISHED BY EMPLOYING TWO CABLE GRIPPERS ON AN APPLICABLY SIZED COME-A-LONG TYPE MECHANICAL HOIST. THE STEEL WIRE ROPE SHALL BE TENSIONED SUFFICIENTLY SO AS TO BE TAUT, BUT NOT SO AS MUCH AS TO DAMAGE THE ITEM TIEDOWN POINTS. THE NUTS ON THE CABLE CLIPS SHALL BE TIGHTENED TO A TORQUE OF APPROXIMATELY 135 TO 150 FOOT-POUNDS. A PROPER TORQUE CAN BE ACHIEVED BY USING A WRENCH WHICH HAS A HANDLE THAT IS AT LEAST 24" LONG. WHEN USING A STEEL WIRE ROPE WHICH IS LARGER THAN 5/8", THE NUTS WILL BE TIGHTENED SECURELY. SEE GENERAL NOTE "L" ON PAGE 2.
3. NARROWER CARS CAN BE USED FOR SHIPMENT OF THIS ITEM. THE TRIPLED SIDE BLOCKING PIECES AND RUBBING STRIPS MUST BE PRE-POSITIONED AND NAILED PRIOR TO LOADING OF THE TRUCK. THE ITEM WILL BE FIELD CHECKED AND THE SIDE BLOCKING MATERIAL MARKED AS KEY NUMBERS ② , ③ , ④ , ⑤ , AND ⑥ , WILL BE POSITIONED SO AS TO BEAR AGAINST THE INSIDE SURFACE OF THE TIRES OF THE TRUCK.

BILL OF MATERIAL		
LUMBER	LENGTH	BOARD FEET
2" X 4" ( 51 MM X 102 MM )	63 ( 19,202 MM )	42
2" X 6" ( 51 MM X 152 MM )	21 ( 6,405 MM )	21
8" X 8" ( 203 MM X 203 MM )	12 ( 3,658 MM )	64
NAILS	NO. REQD	WEIGHT
SIZE AS REQD	162	11 LBS
ROPE, STEEL WIRE, 5/8" DIA	200' REQD	138 LBS
CLIP, 5/8"	50 REQD	32 LBS
WATERPROOF PAPER OR BURLAP	AS REQD	NIL

**LOAD AS SHOWN**

ITEM	QUANTITY	WEIGHT ( APPROX )
SUPPORT EQUIPMENT TRUCK	1	32,804 LBS ( 14,896 KG )
DUNNAGE		499 LBS ( 227 KG )
<b>TOTAL WEIGHT</b>		<b>33,339 LBS ( 15,123 KG )</b>

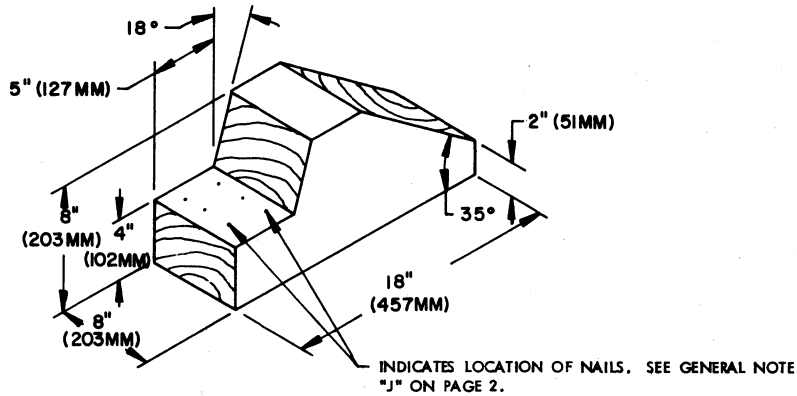

WHEEL BLOCK

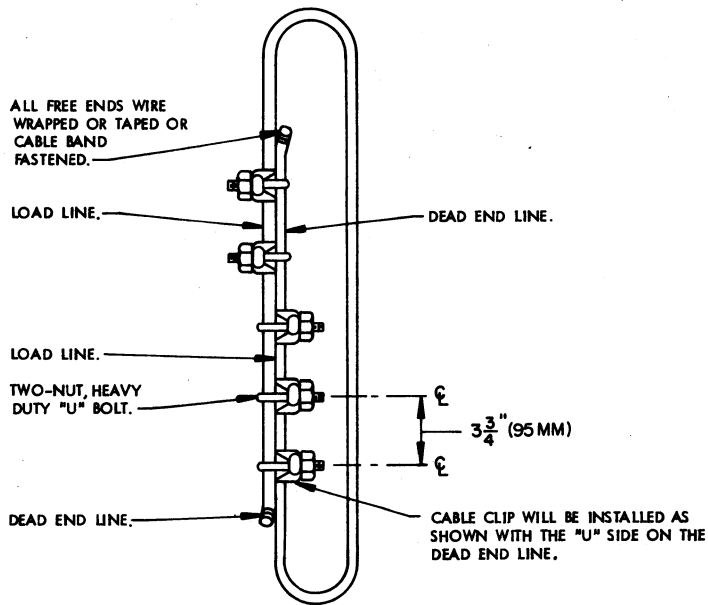

CABLE JOINT

PROPER TIGHTENING OF THE WIRE ROPE CLIP NUTS CAN BE ACCOMPLISHED BY UTILIZING A PROPER SIZED TORQUE WRENCH. AFTER THE NUTS HAVE BEEN INITIALLY TIGHTENED TO THE SPECIFIED TORQUE, THE "U" SIDE OF EACH CLIP MUST BE STRUCK SEVERAL TIMES WITH A HAMMER TO INSURE PROPER SEATING INTO THE DEAD END LINE. FINAL TORQUE WILL BE ACQUIRED BY REPEATEDLY AND ALTERNATELY TIGHTENING EACH CLIP NUT.