















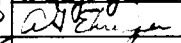

# LANCE

## LOADING AND BRACING ON EUROPEAN RAILCAR OF SHELTER, ELECTRICAL EQUIPMENT, MODIFIED S 250-G (CRATED)

 DELINEATED LOADING AND BRACING PROCEDURES COMPLY  
 WITH THE REGOLAMENTO INTERNAZIONALE VEICOLI  
 (RIV): REGULATIONS GOVERNING THE RECIPROCAL  
 USE OF WAGONS IN INTERNATIONAL TRAFFIC

NOTICE: DEPICTED LOAD IS NOT OVERSIZE

DO NOT SCALE

REVISIONS				DRAFTSMAN	PROJ. ENG.	AMCPM - LCOM
1	MAR 76	 	 	    	  	
				APPROVED		
				 U. S. ARMY MATERIEL COMMAND		
				APPROVED BY ORDER OF COMMANDING GENERAL U. S. ARMY MATERIEL COMMAND		
				 USAMC AMMO CENTER		
				U. S. ARMY MATERIEL COMMAND		
				JUNE 1973		
		CLASS	DIVISION	DRAWING	FILE	
		19	48	7808	GSE 5LC17	

**GENERAL NOTES**

- A. THIS DOCUMENT HAS BEEN PREPARED AND ISSUED IN ACCORDANCE WITH AR 740-1.
- B. THE OUTLOADING PROCEDURES SHOWN HEREIN ARE APPLICABLE TO EUROPEAN RAILCARS WHICH CONFORM TO THE RIV REQUIREMENTS.
- C. THE LOAD AS SHOWN IS BASED ON RIV RAILCARS ( K85 442/443 AND KLS 442/443 ) 41'-0-1/8" ( 12,500 MM ) LONG BY 9'-1-3/4" ( 2,770 MM ) WIDE WITH 18" ( 457 MM ) CAR SIDES. ADDITIONAL UNITS OR OTHER ITEMS MAY BE LOADED ON THE CAR, WITH THE VIEW TOWARD FULL UTILIZATION OF CARRIER EQUIPMENT.
- D. LADING DATA:  
 ITEM DIMENSIONS ---- 9' - 7" ( 2,921 MM ) LONG BY 7' - 4-1/2" ( 2,248 MM ) WIDE BY 6' - 10" ( 2,083 MM ) HIGH.  
 ITEM GROSS WEIGHT -- 1,675 POUNDS ( 760 KG ) ( APPROX ).
- E. A LIST OF RAILCARS THAT MAY BE USED FOR SHIPMENTS OF THE DEPICTED LOAD IS SHOWN IN THE CHART ON THIS PAGE. OTHER TYPES OF RAILCARS CAN BE USED PROVIDING THESE OTHER CARS ARE PROPERLY EQUIPPED FOR THE APPLICATION OF THE PRESCRIBED LOAD-SECURING BLOCKING IN ACCORDANCE WITH THE SPECIFIED PROCEDURES. MINOR DEVIATIONS FROM THE LOCATIONS SHOWN IN THE LOAD VIEWS FOR INSTALLING BLOCKING AND TIE DOWN COMPONENTS ON A CAR ARE PERMITTED. HOWEVER, THE INTENT OF THE SPECIFIED BLOCKING PROCEDURES MUST BE ACHIEVED.
- F. REMOVE ALL POSTS FROM SIDE OF CAR AND PLACE IN RACKS UNDER CAR, IF APPLICABLE.
- G. THE NUMBER OF UNITS MAY BE ADJUSTED TO FIT THE RAILCAR CONCERNED, OR THE QUANTITY TO BE SHIPPED; HOWEVER, THE APPROVED METHODS CONTAINED HEREIN, FOR FULL OR PARTIAL CARLOAD, MUST BE FOLLOWED FOR BLOCKING, BRACING, AND STAYING OF THIS ITEM.
- H. **NOTICE:** A STAGGERED NAILING PATTERN WILL BE USED WHEREVER POSSIBLE WHEN NAILS ARE DRIVEN INTO JOINTS OF DUNNAGE ASSEMBLIES. ALSO, A STAGGERED NAILING PATTERN WILL BE USED WHEN DUNNAGE IS NAILED TO THE FLOOR OF THE RAILCAR, OR WHEN LAMINATING DUNNAGE. THE NAILING PATTERN WILL BE ADJUSTED AS REQUIRED SO THAT A NAIL DOES NOT PENETRATE INTO OR NEAR A CRACK BETWEEN FLOOR BOARDS. ADDITIONALLY, THE NAILING PATTERN FOR AN UPPER PIECE OF LAMINATED DUNNAGE WILL BE ADJUSTED AS REQUIRED SO THAT A NAIL FOR THAT PIECE WILL NOT BE DRIVEN THROUGH ON-TO OR RIGHT BESIDE A NAIL IN A LOWER PIECE.
- J. NAILS USED FOR FLOOR LINE BLOCKING WILL HAVE A MINIMUM DIAMETER OF 5 MM. NAIL SIZES WILL BE SELECTED TO PROVIDE A MINIMUM OF 40 MM PENETRATION INTO THE CAR FLOOR. HOWEVER, THE LENGTH OF THE NAIL WILL BE SUCH THAT THE NAIL DOES NOT COMPLETELY PENETRATE THE CAR FLOOR. SEE THE "NAIL CHART" AT THE RIGHT AND THE "TYPICAL NAILING OF FLOOR LINE BLOCKING TO CAR FLOOR" DETAIL ON PAGE 3. NAILS WHICH ARE OF OTHER SIZES OR WHICH HAVE A NOMENCLATURE DIFFERENT THAN THAT USED HEREIN, MAY ALSO BE USED PROVIDED THEY MEET THE MINIMUM REQUIREMENTS STIPULATED WITHIN THIS DOCUMENT.
- K. NAILS USED FOR FABRICATING DUNNAGE ASSEMBLIES SHALL BE OF THE MAXIMUM PRACTICAL LENGTH WHICH WILL PREVENT THE NAIL POINT FROM COMPLETELY PENETRATING THE DUNNAGE ASSEMBLY. THE NAIL POINT IS TO BE CONCEALED WITHIN THE DUNNAGE ASSEMBLY TO PREVENT DAMAGE TO THE LADING.
- L. STEEL WIRE USED FOR HOLD-DOWNS MUST HAVE A MINIMUM DIAMETER OF 3 MM, WHERE REQUIRED WITHIN THIS DOCUMENT, NO. 8 GAGE BLACK ANNEALED WIRE HAS BEEN SPECIFIED FOR WIRE HOLD-DOWNS. IF DESIRED, OR IF NO. 8 GAGE WIRE IS NOT AVAILABLE, WIRE OF A LARGER DIAMETER, OR 3/8" ( OR LARGER ) STEEL WIRE ROPE, MAY BE SUBSTITUTED.
- M. THE PROCEDURES DEPICTED WITHIN THIS DRAWING ARE BASED ON THE USE OF DIMENSIONAL SIZED LUMBER. IN MOST CASES THE METRIC EQUIVALENT IS GIVEN IN PARENTHESIS FOLLOWING THE DIMENSION. HOWEVER, WHERE THE METRIC EQUIVALENT IS NOT SHOWN, IT MAY BE COMPUTED BY USING 1" EQUALS 25.4 MM. METRIC EQUIVALENTS FOR WEIGHTS ARE BASED ON 1 LB EQUALS 0.454 KG. METRIC EQUIVALENTS FOR TORQUE ARE BASED ON 1 FOOT-POUND EQUALS 0.7376 NEWTON-METERS.

NAIL CHART		
SIZE	LENGTH	DIAMETER
10d	3" ( 76 MM )	0.1483" ( 3.77 MM )
12d	3-1/4" ( 83 MM )	0.1483" ( 3.77 MM )
16d	3-1/2" ( 89 MM )	0.1620" ( 4.11 MM )
20d	4" ( 102 MM )	0.1920" ( 4.88 MM )
30d *	4-1/2" ( 114 MM )	0.2070" ( 5.26 MM )
40d *	5" ( 127 MM )	0.2253" ( 5.72 MM )
50d *	5-1/2" ( 140 MM )	0.2437" ( 6.19 MM )
60d *	6" ( 152 MM )	0.2625" ( 6.67 MM )

\* NAILS WHICH HAVE ADEQUATE DIAMETER FOR NAILING FLOOR LINE BLOCKING. THE LENGTH OF THE NAIL MUST MEET THE REQUIREMENTS OF GENERAL NOTE "J".

LIST OF RAILCARS THAT MAY BE USED FOR SHIPMENTS			
TYPE OF RAILCAR	LENGTH OF RAILCAR	NO. OF ITEMS	MAXIMUM TOTAL WEIGHT ( APPROX ) OF ITEMS
KLMS 440	34'-11-11/16" ( 10,660 MM )	2	3,350 LBS ( 1,520 KG )
KLM 505	30'-4-9/16" ( 9,260 MM )	2	3,350 LBS ( 1,520 KG )
KLM 506	34'-8-1/2" ( 10,580 MM )	2	3,350 LBS ( 1,520 KG )
KBS 442/443	41'-0-1/8" ( 12,500 MM )	3	5,025 LBS ( 2,279 KG )
KLS 442/443	41'-0-1/8" ( 12,500 MM )	3	5,025 LBS ( 2,279 KG )
RMMS 663/664	41'-5-51/64" ( 12,644 MM )	3	5,025 LBS ( 2,279 KG )
RS 680/681	60'-8-23/64" ( 18,500 MM )	4	6,700 LBS ( 3,039 KG )
RS 683/684	60'-8-23/64" ( 18,500 MM )	4	6,700 LBS ( 3,039 KG )
SAS 710	49'-2-9/16" ( 15,000 MM )	3	5,025 LBS ( 2,279 KG )

**MATERIAL SPECIFICATIONS**

- LUMBER** ----- : DOUGLAS FIR OR COMPARABLE LUMBER WITH STRAIGHT GRAIN AND FREE FROM MATERIAL DEFECTS. REF: FED SPEC MM-L-751.
- NAILS** ----- : COMMON, CEMENT COATED OR CHEMICALLY ETCHED. REF: FED SPEC FF-N-105. ALT: ANNULAR-RING TYPE NAIL OF THE SAME SIZE.
- WIRE** ----- : ANNEALED, BLACK. REF: FED SPEC QQ-W-461.
- EDGE PROTECTOR** ----- : COMMERCIAL GRADE.
- ROPE** ----- : STEEL WIRE, PLAIN, PREFORMED, REGULAR LAY. REF: FED SPEC RR-W-410.
- CLIP** ----- : "U" BOLT, CROSBY, HEAVY DUTY ( OR EQUAL ). REF: FED SPEC FF-C-450, TYPE 1, CLASS 1.

**REVISIONS**

- REVISION NO. 1, DATED MARCH 1976, CONSISTS OF:
1. UPDATING THE DRAWING FORMAT.
  2. UPDATING THE GENERAL NOTES.

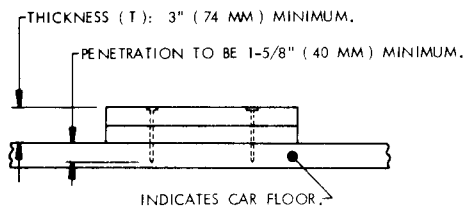

DOUBLED 2' X 6' LUMBER SHOWN

DETAIL A

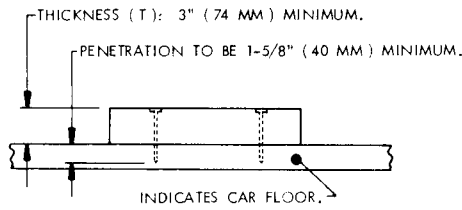

4' X 6' LUMBER SHOWN

DETAIL B

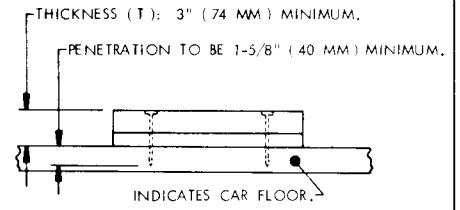

MIXED THICKNESSES OF LUMBER SHOWN

DETAIL C

TYPICAL NAILING OF FLOOR LINE BLOCKING TO CAR FLOOR

SPECIAL NOTES:

1. THE DETAILS ON THIS PAGE DEPICT POSSIBLE VARIATIONS THAT MAY RESULT FROM USING AVAILABLE LUMBER FOR FLOOR LINE BLOCKING. KEY NUMBERS THROUGHOUT THIS DOCUMENT SPECIFY DOUBLED OR TRIPLED PIECES OF LUMBER 2" X 6" IN SIZE FOR HEADERS, BACK-UP CLEATS, AND SIDE-BLOCKING, AS TYPICALLY SHOWN IN DETAIL A ABOVE AND DETAIL D BELOW. IT IS PERMISSIBLE TO USE 4" X 6" LUMBER, OR MIXED THICKNESSES OF LUMBER, AS TYPICALLY SHOWN IN DETAILS B AND C, IN LIEU OF THE SPECIFIED DOUBLED 2" X 6" LUMBER. WHERE TRIPLED 2" X 6" LUMBER IS SPECIFIED, AS TYPICALLY SHOWN IN DETAIL D BELOW, IT IS PERMISSIBLE TO USE MIXED THICKNESSES OF LUMBER, AS TYPICALLY SHOWN IN DETAILS E AND F, IN LIEU OF THE SPECIFIED TRIPLED 2" X 6" LUMBER. THE INTENT OF THE SPECIFIED BLOCKING PROCEDURE MUST BE OBTAINED.
2. THE NUMBER OF NAILS USED TO SECURE EACH PIECE OF BLOCKING WILL BE AS SPECIFIED IN THE KEY NUMBERS FOR EACH SPECIFIC PROCEDURE. THE LENGTH OF THE NAILS SELECTED WILL BE ADEQUATE TO NAIL THROUGH THE BLOCKING AND ACHIEVE THE PENETRATION OF THE CAR FLOOR AS SPECIFIED. WHEN NAILING FLOOR LINE BLOCKING TO THE CAR FLOOR, AS DEPICTED IN DETAILS A, B, AND C, THE FOLLOWING APPLIES:

THICKNESS (T) OF BLOCKING		SIZE OF NAIL
MINIMUM	MAXIMUM	
3" (74 MM)	3" (74 MM)	30d (4-1/2") (114 MM)
3" (74 MM)	3-3/8" (87 MM)	40d (5") (127 MM)
3-3/8" (87 MM)	4" (100 MM)	50d (5-1/2") (140 MM)
4" (100 MM)	4-3/8" (112 MM)	60d (6") (152 MM)

3. WHEN NAILING AN ADDITIONAL LAMINATION TO FLOOR LINE BLOCKING, THE LENGTH OF THE NAIL WILL BE ADEQUATE TO PENETRATE THE ADDITIONAL LAMINATION AND PROVIDE THE PENETRATION OF THE FLOOR LINE BLOCKING AS SPECIFIED IN DETAILS D, E, AND F.

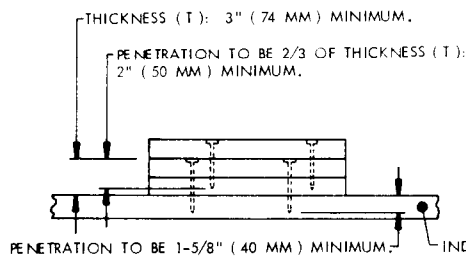

TRIPLED 2' X 6' LUMBER SHOWN

DETAIL D

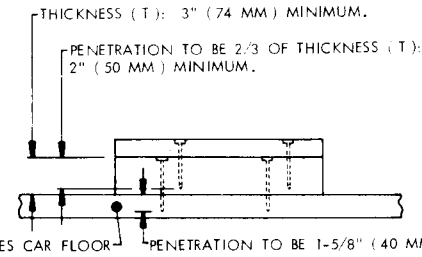

2' X 6' AND 4' X 6' LUMBER SHOWN

DETAIL E

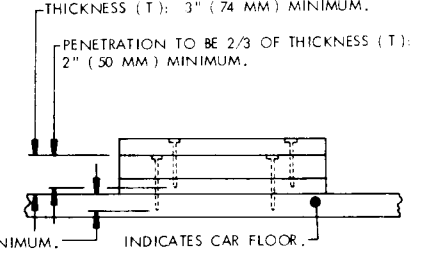

MIXED THICKNESSES OF LUMBER SHOWN

DETAIL F

TYPICAL NAILING OF ADDITIONAL LAMINATIONS TO FLOOR LINE BLOCKING

APPLICATION OF STAGGERED NAILING PATTERN. SEE GENERAL NOTE "H" ON PAGE 2.

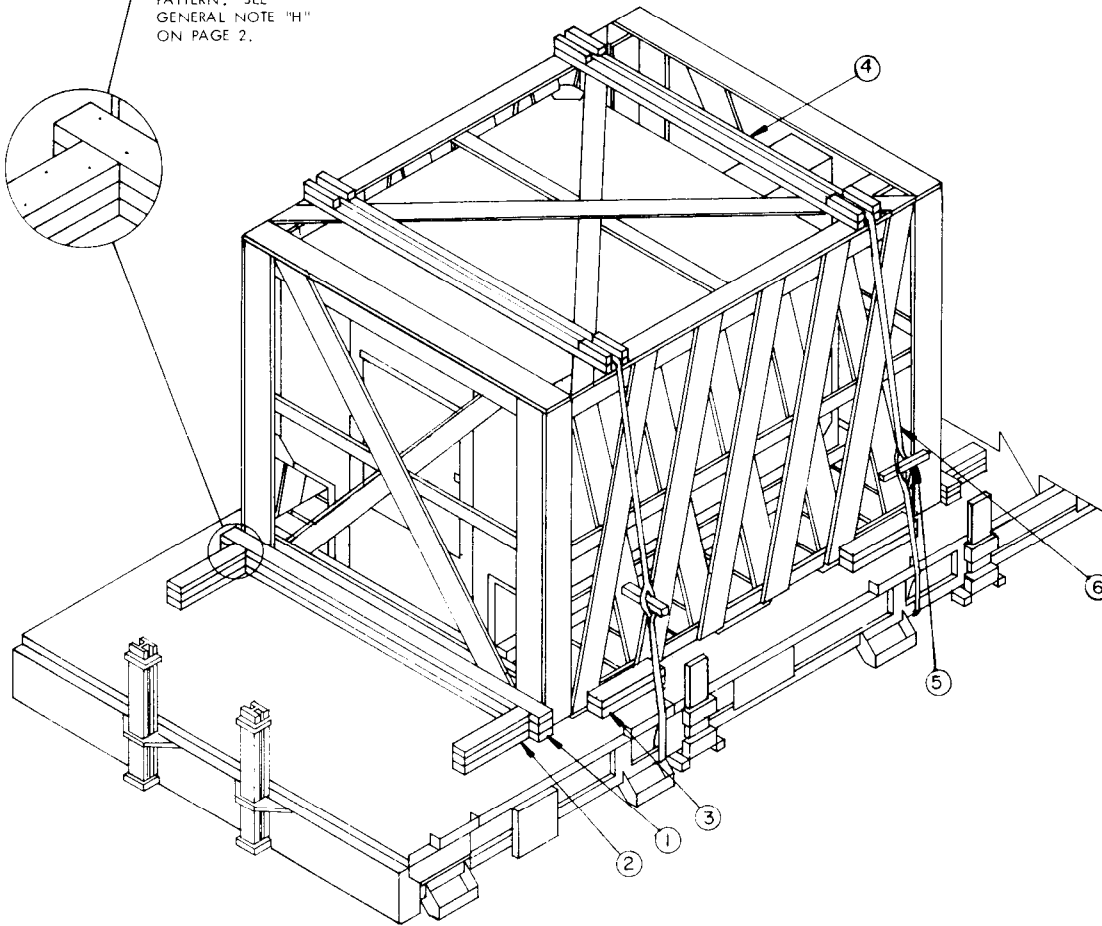

ISOMETRIC VIEW

KEY NUMBERS

- ① HEADER, 2" X 6" X 7'-6" (51 MM X 152 MM X 2,286 MM) (TRIPLED) (2 REQD). PLACE THE SECOND PIECE DIRECTLY ON TOP OF THE FIRST AND NAIL THRU BOTH PIECES AND INTO THE CAR FLOOR W/20 NAILS. PLACE THE THIRD PIECE DIRECTLY ON TOP OF THE FIRST TWO PIECES AND NAIL THRU PIECE THREE INTO PIECES ONE AND TWO W/20 NAILS. SEE GENERAL NOTE "H" ON PAGE 2. REFER TO THE "TYPICAL NAILING OF FLOOR LINE BLOCKING TO CAR FLOOR" DETAIL ON PAGE 3.
- ② BACK-UP CLEAT, 2" X 6" X 24" (51 MM X 152 MM X 610 MM) (TRIPLED) (4 REQD). POSITION AS SHOWN TO ALIGN WITH A SKID ON THE CRATE. PLACE THE SECOND PIECE DIRECTLY ON TOP OF THE FIRST AND NAIL THRU BOTH PIECES AND INTO THE CAR FLOOR W/6 NAILS. PLACE THE THIRD PIECE DIRECTLY ON TOP OF THE FIRST TWO PIECES AND NAIL THRU PIECE THREE INTO PIECES ONE AND TWO W/6 NAILS.
- ③ SIDE BLOCKING, 2" X 6" X 18" (51 MM X 152 MM X 457 MM) (DOUBLED) (4 REQD). POSITION AGAINST A SKID ON THE CRATE, AS SHOWN. PLACE ONE PIECE DIRECTLY ON TOP OF ANOTHER AND NAIL THRU BOTH PIECES AND INTO THE CAR FLOOR W/3 NAILS.
- ④ TIE DOWN BOARD ASSEMBLY (2 REQD). SEE THE "TIE DOWN BOARD ASSEMBLY" DETAIL ON PAGE 5.
- ⑤ WIRE TWISTER, 2" X 2" (51 MM X 51 MM) BY A LENGTH TO SUIT (4 REQD). SEE SPECIAL NOTE 2 ON PAGE 5.
- ⑥ WIRE HOLD-DOWN, SIX (6) STRANDS OF NO. 8 GAGE (3 MM MINIMUM DIAMETER) BLACK ANNEALED WIRE (2 REQD). PASS THRU A RAILCAR TIEDOWN FACILITY, OVER THE LADING AND THRU A TIEDOWN FACILITY ON THE OPPOSITE SIDE OF THE RAILCAR, AND BACK OVER THE LADING TO FORM A COMPLETE LOOP. TWIST TAUT WITH PIECE MARKED ⑤. SEE GENERAL NOTE "L" ON PAGE 2, AND SPECIAL NOTES 3 AND 4 ON PAGE 5.

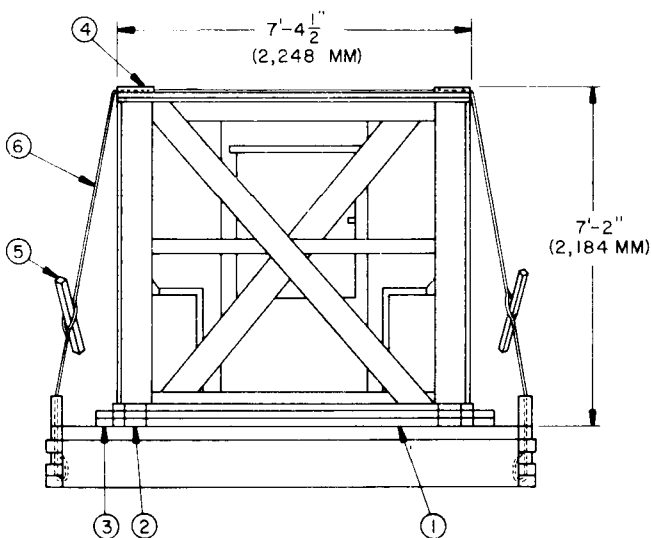

END VIEW

**SPECIAL NOTES:**

1. A ONE UNIT LOAD IS SHOWN ON A 9'-1-3/64" (2,770 MM) WIDE EUROPEAN RAILCAR. SEE GENERAL NOTE "E" ON PAGE 2.
2. THE WIRE TWISTERS, PIECES MARKED (S), MUST NOT PROTRUDE BEYOND THE SIDES OF THE CAR WHEN SECURED FOR MOVEMENT. THE TWISTER SHALL BE SECURED TO PREVENT UNTWISTING AND LOOSENING OF THE WIRE HOLD-DOWN.
3. AT ANY LOCATION WHERE THE TWISTED WIRE HOLD-DOWN PASSES AROUND A SHARP CORNER, PROVIDE SUITABLE CUSHIONING OR BUFFERING MATERIAL TO PROTECT THE WIRE FROM BEING CUT ON THE SHARP CORNER.
4. IF DESIRED, OR IF ANNEALED WIRE IS NOT AVAILABLE FOR FABRICATING TWISTED WIRE HOLD-DOWNS, MARKED AS KEY NUMBER (C), 3/8" (OR LARGER) STEEL WIRE ROPE MAY BE INSTALLED IN LIEU OF THE TWISTED WIRE HOLD-DOWNS. ONE END OF THE STEEL WIRE ROPE WILL PASS THRU A RAILCAR TIEDOWN FACILITY, WILL BE FOLDED BACK UPON THE OTHER LEG OF THE ROPE, AND BE SECURED WITH THREE CLIPS, AS SHOWN IN THE "CABLE JOINT" DETAIL ON THIS PAGE. THE STEEL WIRE ROPE WILL THEN PASS OVER THE LADING, ON TOP OF THE TIE-DOWN BOARD, AND THE OTHER END OF THE STEEL WIRE ROPE WILL BE PASSED THROUGH A RAILCAR TIEDOWN FACILITY ON THE OPPOSITE SIDE OF THE CAR AND BE SECURED IN THE SAME MANNER. TENSIONING OF THE STEEL WIRE ROPE CAN BE ACCOMPLISHED BY EMPLOYING TWO CABLE GRIPPERS ON AN APPLICABLE SIZED COME-ALONG TYPE MECHANICAL JOIST. THE STEEL WIRE ROPE SHALL BE TENSIONED SUFFICIENTLY SO AS TO BE TAUT, BUT NOT SO MUCH AS TO DAMAGE THE CONTAINER. THE NUTS ON THE CABLE CLIPS SHALL BE TIGHTENED TO A TORQUE OF APPROXIMATELY 40 FOOT-POUNDS. A PROPER TORQUE CAN BE ACHIEVED BY USING A WRENCH WHICH HAS A HANDLE THAT IS AT LEAST 12" LONG. PROVIDE A THIMBLE OR OTHER SUITABLE PROTECTION AT ANY POINT WHERE THE WIRE ROPE PASSES AROUND A SHARP CORNER. SECURE EACH THIMBLE WITH AN ADDITIONAL CLIP OR BY EQUIVALENT MEANS. WHEN USING A STEEL WIRE ROPE WHICH IS LARGER THAN 3/8", THE NUTS ON THE CABLE CLIPS SHALL BE TIGHTENED TO A TORQUE OF AT LEAST 60 FOOT-POUNDS. A WRENCH WHICH HAS A HANDLE THAT IS AT LEAST 15" LONG MAY BE USED TO OBTAIN THE 60 FOOT-POUND TORQUE. SEE GENERAL NOTE "M" ON PAGE 2.
5. WHEN SHIPPING TWO OR MORE LOAD UNITS REFER TO THE "TYPICAL PLAN VIEW" SHOWN ON PAGE 6 FOR GUIDANCE CONCERNING PLACEMENT OF HEADERS AND BACKUP CLFATS. EXCEPT AS DESCRIBED ABOVE, ALL BLOCKING, BRACING, AND TIEDOWN COMPONENTS FOR EACH LOAD UNIT WILL BE INSTALLED AS SPECIFIED IN THE KEY NUMBERS ON PAGE 4.

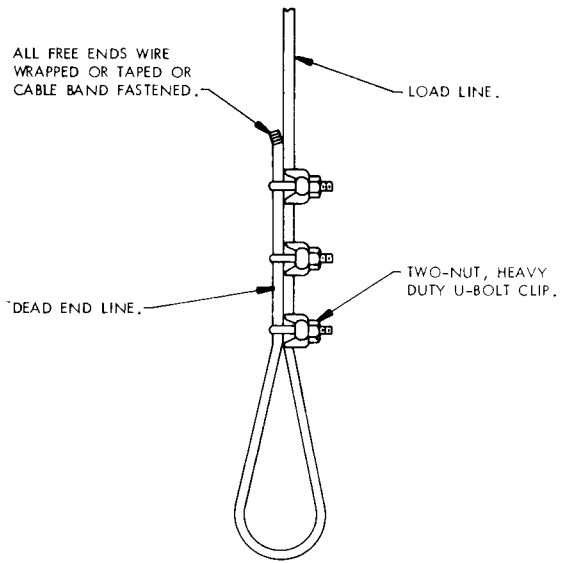

**CABLE JOINT**

PROPER TIGHTENING OF THE WIRE ROPE CLIP NUTS CAN BE ACCOMPLISHED BY UTILIZING A PROPER SIZED TORQUE WRENCH. AFTER THE NUTS HAVE BEEN INITIALLY TIGHTENED, THE "U" SIDE OF EACH CLIP MUST BE STRUCK SEVERAL TIMES WITH A HAMMER TO INSURE PROPER SEATING INTO THE DEAD END LINE. FINAL TORQUE WILL BE ACQUIRED BY REPEATEDLY AND ALTERNATELY TIGHTENING EACH CLIP NUT.

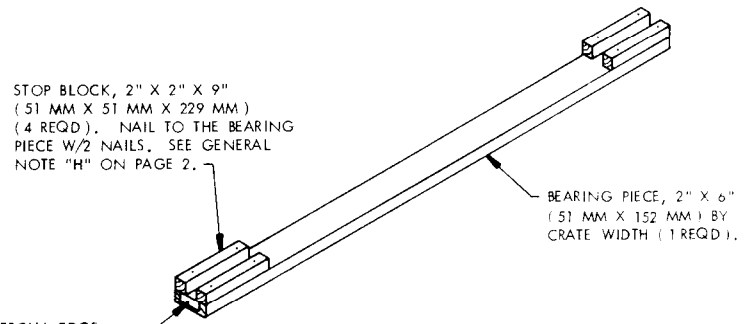

EDGE PROTECTOR (2 REQD). USE COMMERCIAL EDGE PROTECTOR OR FABRICATE FROM A 4" X 4" PIECE OF 18 GAGE SHEET STEEL. INSTALL PRIOR TO NAILING STOP BLOCK TO BEARING PIECE.

**TIE DOWN BOARD ASSEMBLY**

BILL OF MATERIAL		
LUMBER	LENGTH	BOARD FEET
2" X 2" (51 MM X 51 MM)	12 FT (3,658 MM)	4
2" X 6" (51 MM X 152 MM)	96 FT (29,261 MM)	96
NAILS	NO. REQD	WEIGHT
SIZE AS REQD	196	10 LBS
WIRE NO. 8 GAGE (3 MM DIA)	150' REQD	14 LBS
EDGE PROTECTOR	4 REQD	NIL

**LOAD AS SHOWN**

ITEM	QUANTITY	WEIGHT (APPROX)
SHELTER (CRATED)	1	1,675 LBS (760 KG)
DUNNAGE		274 LBS (124 KG)
<b>TOTAL WEIGHT</b>		<b>1,949 LBS (884 KG)</b>

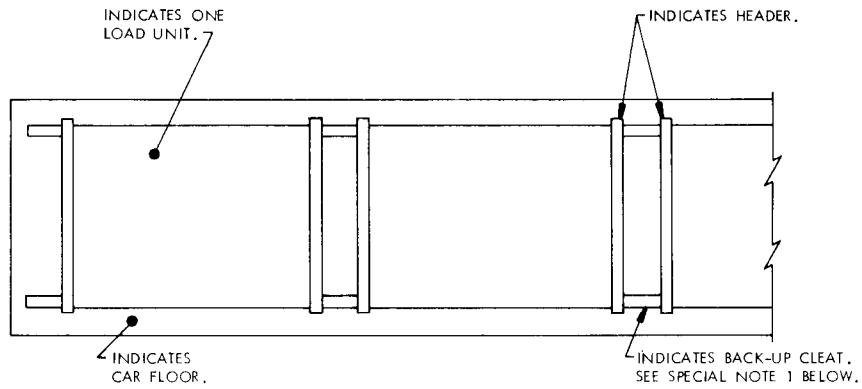

TYPICAL PLAN VIEW

SIDE BLOCKING AND TIEDOWN COMPONENTS HAVE BEEN OMITTED FOR CLARITY PURPOSES.

SPECIAL NOTES:

1. FOR SHIPMENT OF TWO OR MORE CRATED ITEMS, REFER TO THE TYPICAL PLAN VIEW ABOVE, AND ADJUST THE NUMBER OF HEADERS AND BACKUP CLEATS AS SHOWN. EXCEPT AS DESCRIBED ABOVE, ALL BLOCKING, BRACING, AND TIEDOWN COMPONENTS FOR EACH LOAD UNIT WILL BE INSTALLED AS SPECIFIED IN THE KEY NUMBERS ON PAGE 4.