

APPROVED BY
MTMTS

Frank L. Pluse

TEA, MTMTS

DATE *2/4/72*

HAWK

MINIMUM REQUIREMENTS FOR THE HANDLING, STOWAGE AND BRACING ABOARD SHIPS OF LAUNCHER, ZERO LENGTH, GUIDED MISSILE, XM78E3 AND / OR XM192

REVISIONS				DRAFTSMAN	PROJ. ENG.		
				<i>LCM/sib</i>	<i>JNW/llw</i>		
				CHECKED	ADE OFFICE	AMM1-SP	
				<i>WJL/SBZ</i>	<i>John Boyd</i>	<i>EA Baker</i>	
				APPROVED			
				<i>Morris E Johnson</i>			
				U. S. ARMY MISSILE COMMAND			
				APPROVED BY ORDER OF COMMANDING GENERAL			
				U. S. ARMY MATERIEL COMMAND			
				<i>WJ Ehringer</i>			
				USAMC AMMO CENTER			
				U. S. ARMY MATERIEL COMMAND			
				FEBRUARY 1972			
				CLASS	DIVISION	DRAWING	FILE
				19	48	7223	GSE 18HA 4

DO NOT SCALE

NOTES

GENERAL:

- A. THIS DOCUMENT HAS BEEN PREPARED AND ISSUED IN ACCORDANCE WITH AMCR 740-13.
- B. THIS DRAWING DEPICTS MINIMUM PROCEDURES APPLICABLE TO THE HANDLING, STOWAGE, AND BRACING ABOARD SHIPS OF LAUNCHER, ZERO LENGTH, GUIDED MISSILE, XM7BE3 AND/OR XM192 FOR THE HAWK MISSILE SYSTEM.
- C. THE LAUNCHER SHOWN HEREIN MAY BE STOWED IN THE SAME HOLD OR TWEEN DECK WITH OTHER TYPES OF CARGO.
- D. LADING DATA:
 - DIMENSIONS ----- 14'-7" LONG X 8'-0" WIDE X 7'-8" HIGH.
 - GROSS WEIGHT --- 4,380 LBS (APPROX).
 - CUBE ----- 894.4 CU. FT.

HANDLING:

- A. PERTINENT PROVISIONS OF TITLE 46 CODE OF FEDERAL REGULATIONS APPLY.
- B. HANDLING OF THE LAUNCHER SHOULD BE ACCOMPLISHED BY USING THE LIFT POINTS DESIGNATED HEREIN.
- C. THE HANDLING SLING SHALL BE OF A DESIGN AND CONFIGURATION TO LIFT THE ITEM IN SUCH A MANNER THAT THE CABLE LEGS DO NOT COME IN CONTACT WITH OR APPLY PRESSURE AGAINST THE FRAMING, SUPERSTRUCTURE OR OTHER MEMBERS OF THE ITEM WHEN BEING LIFTED.
- D. EACH LEG OF THE HANDLING SLING MUST BE SECURELY ATTACHED TO A LIFT POINT PRIOR TO LIFTING.
- E. ALTHOUGH DESIRABLE, A LEVEL LIFT IS NOT MANDATORY. THE CENTER OF GRAVITY OF THIS ITEM IS SHOWN TO ASSIST IN DETERMINING CABLE LENGTHS TO ASSURE A SAFE LIFT.

STOWAGE AND BRACING:

- A. WHEN STOWING THE LAUNCHER WITHIN THE HOLD OR TWEEN DECK, BRACING BETWEEN LAUNCHERS OR BETWEEN A LAUNCHER AND OTHER CARGO SHALL ONLY BE APPLIED AGAINST THE WHEELS OF THE LAUNCHER TRAILER. ALSO, OTHER CARGO ITEMS MUST NOT BE STACKED ON TOP OF OR BE BRACED AGAINST ANY OTHER PART OF THE LAUNCHER THAN AS IDENTIFIED IMMEDIATELY ABOVE.
- B. SPECIES, GRADE AND SIZE OF LUMBER TO BE USED WILL COMPLY WITH REQUIREMENTS OF CURRENT SHIPWRIGHT-CARPENTRY AND RELATED SERVICES CONTRACTS. BRACING METHODS AND LUMBER SIZES DEPICTED IN THIS DRAWING ARE CONSIDERED MINIMUM AND ARE NOT INTENDED TO CONFLICT WITH CONTRACT REQUIREMENTS.
- C. THE LAUNCHER IS EQUIPPED WITH TIE DOWN DEVICES AS SHOWN HEREIN WHICH ARE SYMMETRICAL ABOUT THE LONGITUDINAL LINE OF CENTER. THE LAUNCHER SHOULD BE SECURED FORE AND AFT TO SHIP TIE DOWN POINTS USING A MINIMUM OF TWO SYMMETRICALLY LOCATED TIE DOWN DEVICES IN EACH DIRECTION AS TYPICALLY SHOWN WITHIN THIS DOCUMENT.
- D. A TYPICAL TIE DOWN PROCEDURE IS SHOWN AND DEPICTS THE PREFERRED METHOD OF USING CABLES AND TURNBUCKLES. IF USED, A TURNBUCKLE MUST BE OF A SIZE EQUAL IN STRENGTH TO THE MINIMUM SIZE CABLE REQUIRED TO SECURE THE ITEM. IN LIEU OF CABLES AND TURNBUCKLES, SECUREMENT MAY BE ACCOMPLISHED BY OTHER ACCEPTED METHODS.

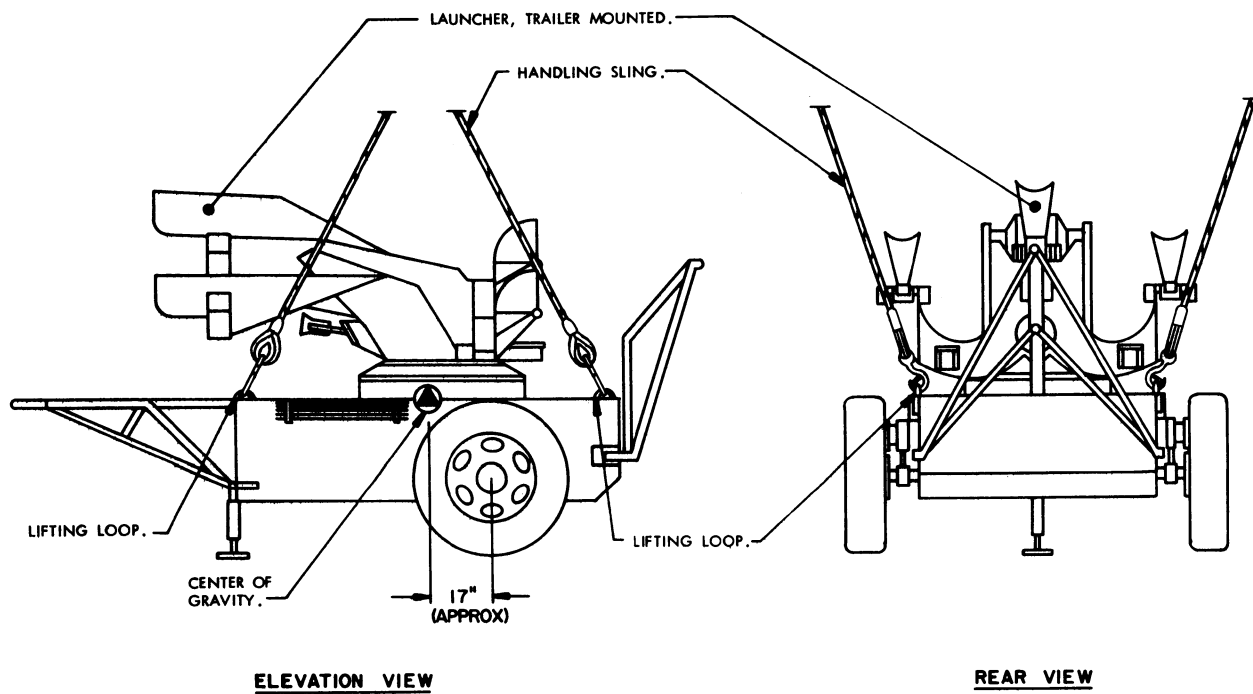

PRECAUTIONARY PROVISIONS FOR HANDLING, STOWAGE AND BRACING AS SPECIFIED IN THE NOTES ON PAGE 2 MUST BE OBSERVED.

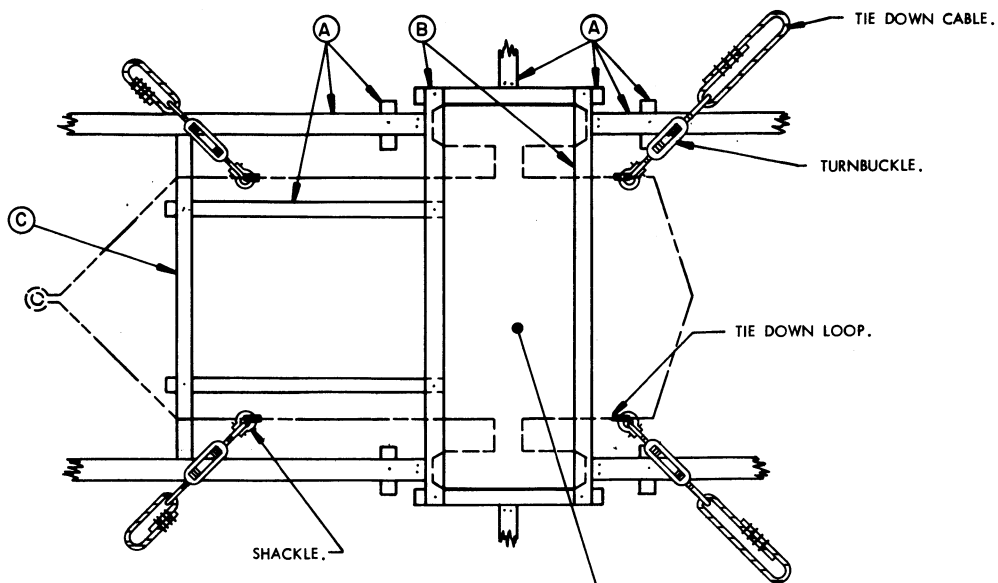

PLAN VIEW
 PHANTOM LINES INDICATE
 TRAILER AND TIRES.

LAUNCHER, TRAILER MOUNTED.

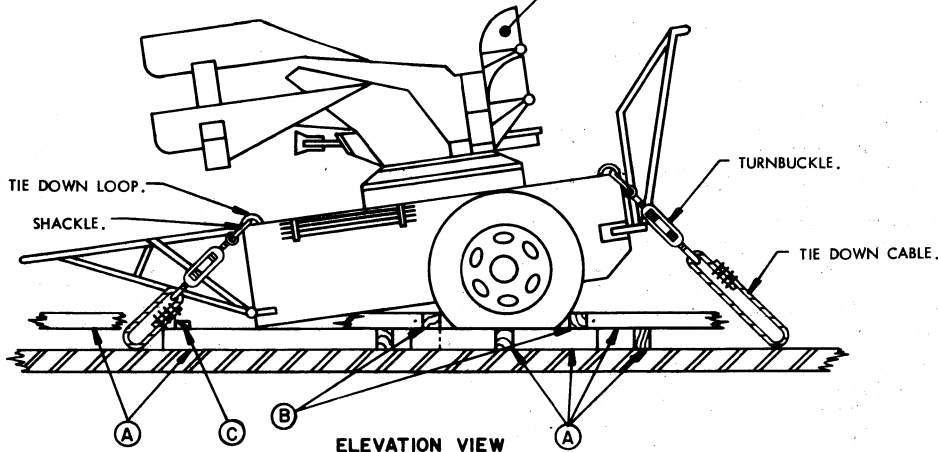

ELEVATION VIEW

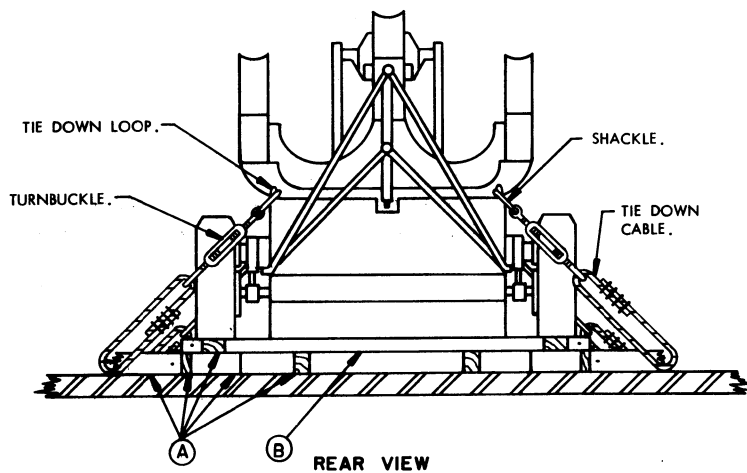

REAR VIEW

MINIMUM LUMBER SIZES	
(A)	4" X 6"
(B)	4" X 4"
(C)	2" X 4"

PRECAUTIONARY PROVISIONS FOR HANDLING,
 STOWAGE AND BRACING AS SPECIFIED IN THE
 NOTES ON PAGE 2 MUST BE OBSERVED.