





LOADING AND BRACING (TL & LTL) ON FLATBED TRAILERS * OF AIM-120 (AMRAAM) MISSILES PACKED IN CNU-431/E METAL CONTAINERS

INDEX

ITEM	PAGE(S)
GENERAL NOTES AND MATERIAL SPECIFICATIONS - - - - -	2
CONTAINER DETAIL - - - - -	3
16-CONTAINER LOAD ON A 40'-0" LONG FLATBED TRAILER - - - - -	4, 5
16-CONTAINER LOAD ON A 40'-0" LONG FLATBED TRAILER (CHAIN TIEDOWN METHOD) - - - - -	6, 7
16-CONTAINER LOAD ON A 40'-0" LONG FLATBED TRAILER (WEB STRAP TIEDOWN METHOD) - - - - -	8, 9
18-CONTAINER LOAD ON A 48'-0" LONG FLATBED TRAILER - - - - -	10, 11
TYPICAL LTL (2-CONTAINER LOAD) - - - - -	12
DETAILS - - - - -	13
PROVISIONS FOR THE USE OF FIRE HOSE - - - - -	14

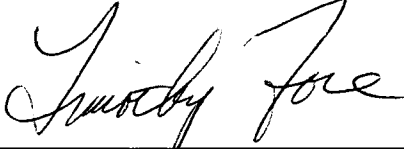
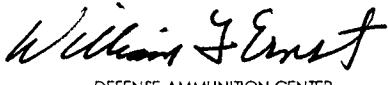
* **CAUTION:** THE OUTLOADING PROCEDURES SHOWN HEREIN ARE ONLY APPLICABLE TO HIGHWAY MOVEMENTS; NOT TRAILER-ON-FLAT CAR MOVEMENTS.

U.S. ARMY MATERIEL COMMAND DRAWING

APPROVED, U.S. ARMY INDUSTRIAL OPERATIONS COMMAND 	ENGINEER	BASIC	SANDRA SCHULTZ	DO NOT SCALE			
		REV.	MICHAEL SARDONE	WEBSITE: HTTP://WWW.DAC.ARMY.MIL			
	TECHNICIAN	BASIC		MAY 1988			
		REV.		REVISION NO. 1	JUNE 1997		
APPROVED BY ORDER OF COMMANDING GENERAL, U.S. ARMY MATERIEL COMMAND  DEFENSE AMMUNITION CENTER	TRANSPORTATION ENGINEERING DIVISION			SEE THE REVISION LISTING ON PAGE 2			
	VALIDATION ENGINEERING DIVISION		 TESTED	CLASS	DIVISION	DRAWING	FILE
	LOGISTICS ENGINEERING OFFICE			19	48	7103	SP11J6

GENERAL NOTES

- A. THIS DOCUMENT HAS BEEN PREPARED AND ISSUED IN ACCORDANCE WITH AR 740-1, AND AUGMENTS TM 743-200-1 (CHAPTER 5).
- B. THE OUTLOADING PROCEDURES CONTAINED HEREIN ARE APPLICABLE TO AIM-120 MISSILES PACKED IN CNU-431/E METAL CONTAINERS. SUBSEQUENT REFERENCE TO CONTAINER HEREIN MEANS THE CNU-431/E CONTAINER WITH CONTENTS.
- C. FOR DETAILS OF THE CNU-431/E CONTAINER, SEE AIR FORCE DRAWING NO. 8644140 AND DETAIL ON PAGE 3.
- CONTAINER DIMENSIONS --- 14'-6" LONG X 38-1/8" WIDE X
18-15/16" HIGH
GROSS WEIGHT ----- 1,913 POUNDS (APPROX)
- D. THE LOADS SHOWN HEREIN ARE BASED ON 8'-0" WIDE BY 40'-0" LONG AND 8'-0" WIDE BY 40'-0" LONG FLATBED TRAILERS. WIDER TRAILERS AND TRAILERS OF OTHER LENGTHS MAY BE USED. TRAILERS MUST HAVE WOOD OR WOOD AND METAL FLOORS. TRAILERS HAVING ALL-METAL FLOORS CANNOT BE USED. CAUTION: IF THE TRAILER FLOOR IS EQUIPPED WITH EXPOSED METAL DECKING ABOVE THE BOGIE ASSEMBLY, OR ELSEWHERE, FIELD MEASUREMENTS SHOULD BE MADE TO ENSURE THAT THE METAL DECKING DOES NOT INTERFERE WITH THE PROPER POSITIONING AND NAILING OF THE DUNNAGE AS SPECIFIED BY THE PROCEDURES SHOWN HEREIN.
- E. SELECTION OF A VEHICLE USED TO TRANSPORT THE DESIGNATED ITEM MUST COMPLY WITH AR 55-355, CHAPTER 29, FOR EXPLOSIVES AND OTHER DANGEROUS ARTICLES, IN FULL.
- F. GROSS WEIGHT AND AXLE DISTRIBUTION OF WEIGHT FOR A LOAD WILL BE THE RESPONSIBILITY OF THE CARRIER. THE CARRIER WILL ADVISE THE SHIPPER OF APPLICABLE LOADING REQUIREMENTS, AND THE SHIPPER WILL LOAD ACCORDINGLY.
- G. NOTICE: A SHIPMENT WILL BE POSITIONED ON A TRAILER CONSISTENT WITH STATE WEIGHT LAWS.
- H. OTHER TYPES OF LADING ITEMS MAY BE LOADED ON A TRAILER WHICH IS PARTIALLY LOADED WITH THE DESIGNATED ITEM, PROVIDING THE TOTAL LOAD IS COMPATIBLE, EXISTING DIRECTIVES ARE NOT VIOLATED, AND THE OTHER LADING ITEMS ARE BLOCKED AND BRACED TO EQUAL THE BLOCKING AND BRACING CRITERIA SPECIFIED HEREIN.

(CONTINUED AT RIGHT)

MATERIAL SPECIFICATIONS

- LUMBER -----: SEE TM 743-200-1 (DUNNAGE LUMBER) AND FED SPEC MM-L-751.
- NAILS -----: FED SPEC FF-N-105; COMMON.
- STRAP, WEB -----: WEB SLING AND TIEDOWN ASSOCIATION RECOMMENDED STANDARD SPECIFICATION FOR SYNTHETIC WEB TIEDOWNS, FIRST PUBLISHED IN 1991.
- STRAPPING, STEEL ---: ASTM D3953; FLAT STRAPPING, TYPE 1, HEAVY DUTY, FINISH A, B (GRADE 2), OR C.
- SEAL, STRAP -----: ASTM D3953; CLASS H, FINISH A, B (GRADE 2), OR C, DOUBLE NOTCH TYPE, STYLE I, II, OR IV.
- STAPLE, STRAP -----: COMMERCIAL GRADE.
- CHAIN -----: NATIONAL ASSOCIATION OF CHAIN MANUFACTURER'S WELDED CHAIN SPECIFICATION ADOPTED NOVEMBER 1975.
- BINDER, LOAD -----: FED SPEC GGG-B-325.
- ANTI-CHAFING MATERIAL -----: MIL-B-121 (OR EQUAL); NEUTRAL BARRIER MATERIAL.

(GENERAL NOTES CONTINUED)

- J. CAUTION: REGARDLESS OF THE TYPE OF TRAILER INVOLVED, ONLY THOSE TRAILERS HAVING TIEDOWN ANCHORING FACILITIES WHICH PROVIDE HOLDING STRENGTH EQUAL TO OR GREATER THAN THE STRENGTH OF THE HOLD-DOWN STRAPS OR CHAINS AND WHICH ALIGN NEAR THE INDICATED LOCATIONS FOR THE HOLD-DOWN STRAPS OR CHAINS SHOULD BE USED. IF THE TRAILER ANCHOR DEVICES ARE NOT PROPERLY POSITIONED TO RECEIVE STRAPPING OR CHAINS, AS SHOWN, OR IF THE ANCHOR DEVICES ARE NOT EQUAL TO OR GREATER THAN THE STRENGTH OF THE TIEDOWN STRAPS OR CHAINS, STEEL STRAPS MAY BE APPLIED TO FORM A COMPLETE LOOP WHICH ENCOMPASSES BOTH THE LADING AND THE TRAILER FRAME AND/OR BED. CAUTION: AVOID TRAILER WHEELS, FIFTH WHEEL PLATE CONTROLS AND OTHER APPURTENANCES. USE EDGE PROTECTORS OR PADS ON ALL SHARP EDGES. NEITHER CHAINS NOR WEB STRAPS WILL BE APPLIED TO FORM A COMPLETE LOOP WHICH ENCOMPASSES BOTH THE LADING AND THE TRAILER FRAME AND/OR BED.
- K. DUNNAGE LUMBER SPECIFIED THROUGHOUT THIS PROCEDURAL DRAWING IS OF NOMINAL SIZE. FOR EXAMPLE, 2" X 6" MATERIAL IS ACTUALLY 1-1/2" THICK BY 5-1/2" WIDE AND 1" X 4" MATERIAL IS ACTUALLY 3/4" THICK BY 3-1/2" WIDE.
- L. A STAGGERED NAILING PATTERN WILL BE USED WHEN DUNNAGE IS NAILED TO THE FLOOR OF THE TRANSPORTING VEHICLE, OR WHEN LAMINATING DUNNAGE. THE NAILING PATTERN WILL BE ADJUSTED AS REQUIRED SO THAT A NAIL DOES NOT PENETRATE INTO OR NEAR A CRACK BETWEEN FLOOR BOARDS. ADDITIONALLY, THE NAILING PATTERN FOR AN UPPER PIECE OF LAMINATED DUNNAGE WILL BE ADJUSTED AS REQUIRED SO THAT A NAIL FOR THAT PIECE WILL NOT BE DRIVEN THROUGH ONTO OR RIGHT BESIDE A NAIL IN A LOWER PIECE.
- M. WHEN STEEL STRAPPING IS SEALED AT AN END-OVER-END LAP JOINT, A MINIMUM OF ONE SEAL WITH TWO PAIR OF NOTCHES WILL BE USED TO SEAL THE JOINT WHEN A NOTCH-TYPE SEALER IS BEING USED. A MINIMUM OF TWO SEALS, BUTTED TOGETHER, WITH TWO PAIR OF CRIMPS PER SEAL WILL BE USED TO SEAL THE JOINT WHEN A CRIMP-TYPE SEALER IS BEING USED. REFER TO THE "END-OVER-END LAP JOINT DETAILS" ON PAGE 13.
- N. FOR ADDITIONAL GUIDANCE, ATTENTION IS DIRECTED TO THE "SPECIAL NOTES" SECTION WHICH IS IMMEDIATELY ADJACENT TO A DEPICTED OUTLOADING METHOD.
- O. CONVERSION TO METRIC EQUIVALENTS: DIMENSIONS WITHIN THIS DOCUMENT ARE EXPRESSED IN INCHES, AND WEIGHTS ARE EXPRESSED IN POUNDS. WHEN NECESSARY, THE METRIC EQUIVALENTS MAY BE COMPUTED ON THE BASIS OF ONE INCH EQUALS 25.4MM, AND ONE POUND EQUALS 0.454KG.
- P. IF CHAINS AND LOAD BINDERS ARE BEING USED IN LIEU OF STEEL STRAPPING, THE "SPECIAL PROVISIONS FOR CHAIN TIEDOWN" ON PAGE 7 AND THE LOAD SHOWN ON PAGE 6 MUST BE APPLIED TO ENSURE ADEQUATE SECUREMENT OF THE LOAD PRIOR TO SHIPMENT.
- Q. THE TRANSPORTING VEHICLE OPERATOR SHOULD BE INSTRUCTED TO PERIODICALLY INSPECT THE TIEDOWN CHAINS AND LOAD BINDERS DURING TRANSIT AND TIGHTEN IF NECESSARY.
- R. IF WEB STRAPS ARE BEING USED IN LIEU OF STEEL STRAPPING, THE "SPECIAL PROVISIONS FOR WEB STRAP TIEDOWN" ON PAGE 9 AND THE LOAD SHOWN ON PAGE 8 MUST BE APPLIED TO ENSURE ADEQUATE SECUREMENT OF THE LOAD PRIOR TO SHIPMENT.

REVISION

REVISION NO. 1, DATED JUNE 1997, CONSISTS OF:

1. CHANGING CONTAINER WIDTH TO 38-1/8".
2. REMOVING BACK-UP CLEATS FROM LOAD DRAWINGS.
3. MODIFYING SIDE BLOCKING IN LOAD DRAWINGS.
4. ADDING PROCEDURES FOR USE OF 48'-0" LONG TRAILERS.
5. ADDING WEB STRAP TIEDOWN METHOD.
6. INCLUDING PROVISIONS FOR THE USE OF FIREHOSE.
7. UPDATING DRAWING FORMAT.

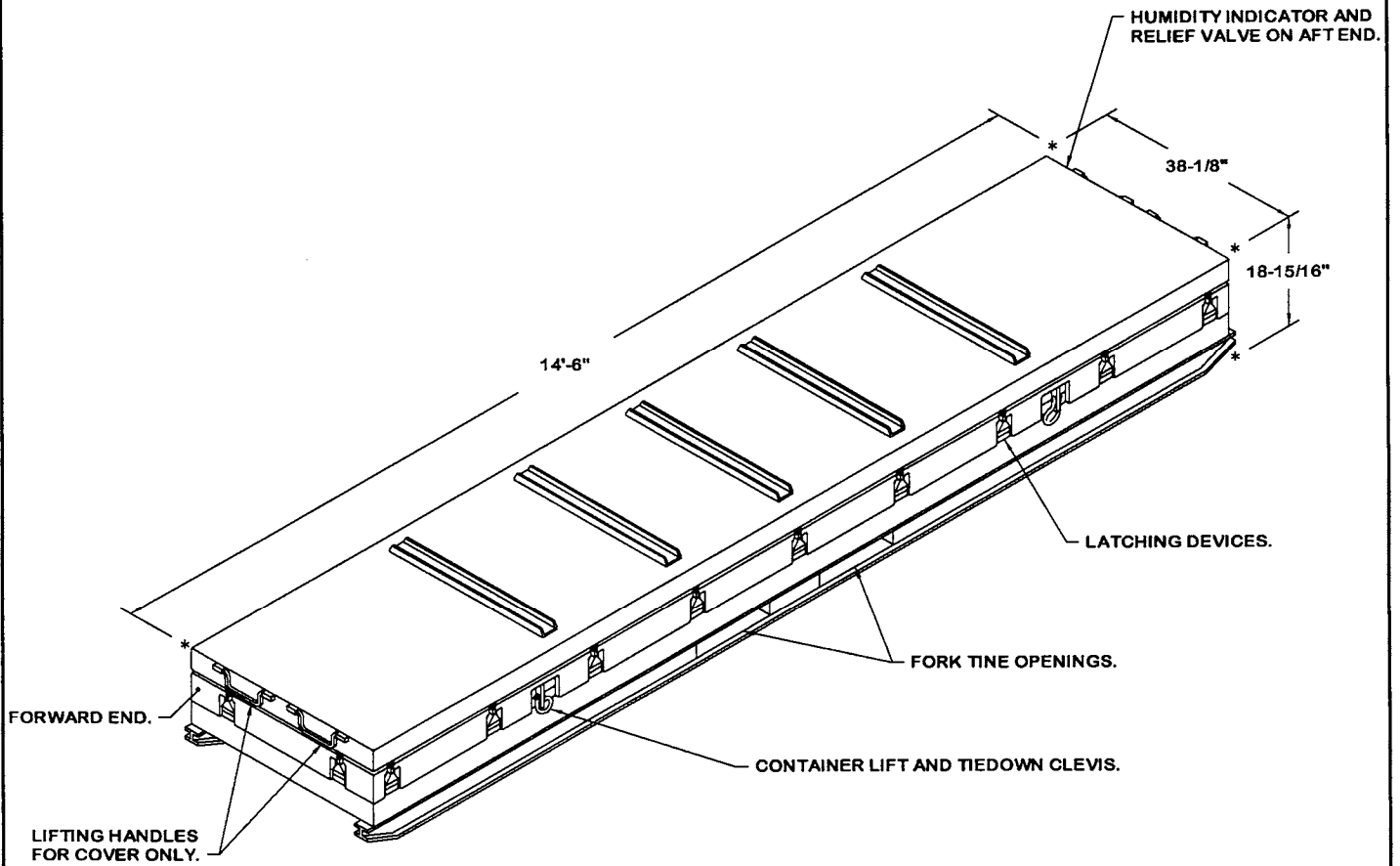

CNU-431/E CONTAINER

(STACKING HEIGHT 17-11/16")

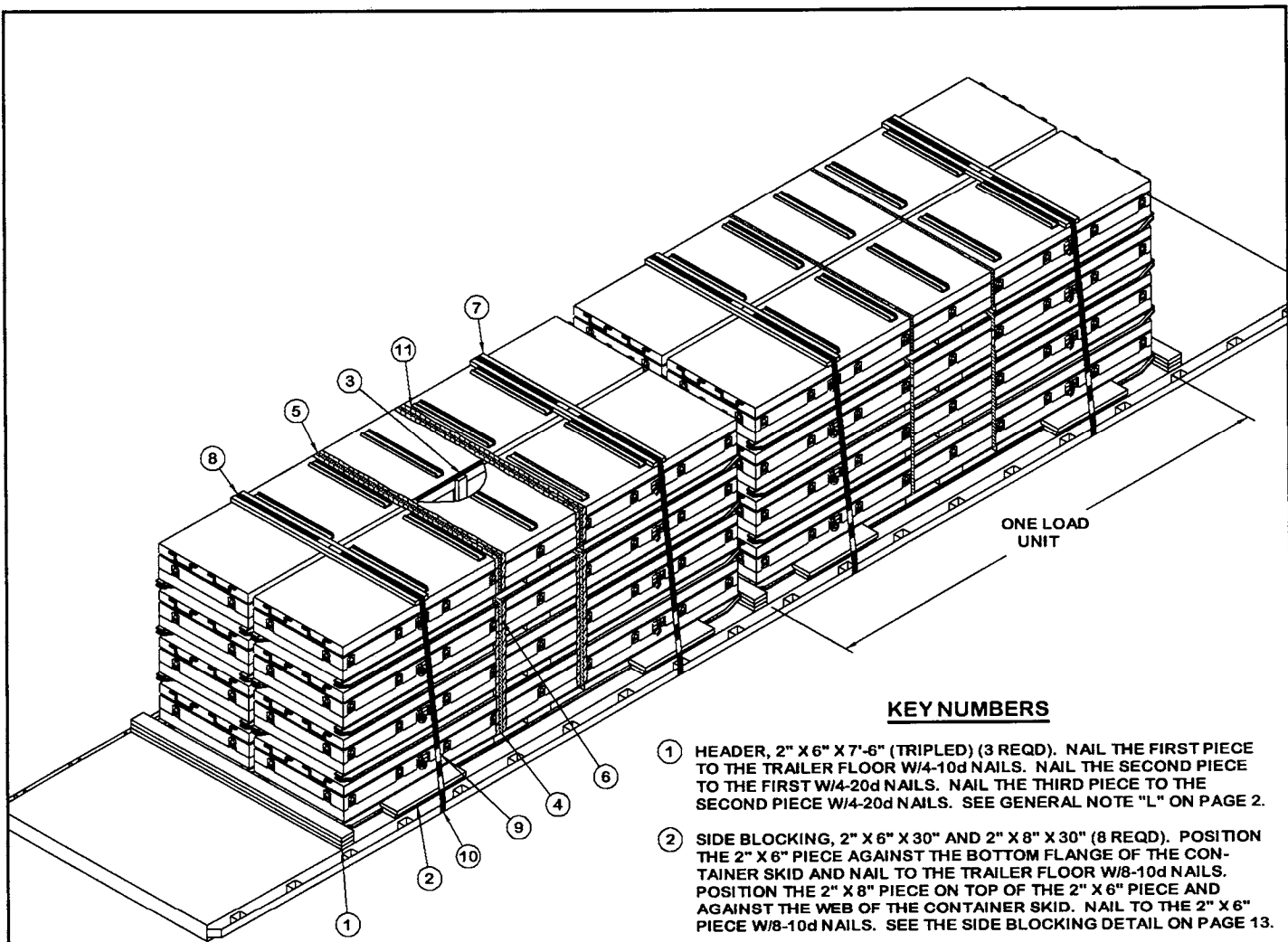

ISOMETRIC VIEW

KEY NUMBERS

- ① HEADER, 2" X 6" X 7'-6" (TRIPLED) (3 REQD). NAIL THE FIRST PIECE TO THE TRAILER FLOOR W/4-10d NAILS. NAIL THE SECOND PIECE TO THE FIRST W/4-20d NAILS. NAIL THE THIRD PIECE TO THE SECOND PIECE W/4-20d NAILS. SEE GENERAL NOTE "L" ON PAGE 2.
- ② SIDE BLOCKING, 2" X 6" X 30" AND 2" X 8" X 30" (8 REQD). POSITION THE 2" X 6" PIECE AGAINST THE BOTTOM FLANGE OF THE CONTAINER SKID AND NAIL TO THE TRAILER FLOOR W/8-10d NAILS. POSITION THE 2" X 8" PIECE ON TOP OF THE 2" X 6" PIECE AND AGAINST THE WEB OF THE CONTAINER SKID. NAIL TO THE 2" X 6" PIECE W/8-10d NAILS. SEE THE SIDE BLOCKING DETAIL ON PAGE 13.
- ③ ANTI-CHAFING ASSEMBLY (2 REQD). SEE THE DETAIL ON PAGE 5.
- ④ STACK UNITIZING STRAP, 1-1/4" X .035" OR .031" X 16'-6" LONG STEEL STRAPPING (8 REQD, 2 PER STACK). INSTALL THROUGH FORK TINE OPENINGS OF UPPER AND LOWER CONTAINERS. STRAPS SHOULD BE POSITIONED AS FAR APART AS THE FORK TINE OPENINGS PERMIT. SEE SPECIAL NOTE 2 ON PAGE 5.
- ⑤ BUNDLING STRAP, 1-1/4" X .035" OR .031" X 17'-0" LONG STEEL STRAPPING (4 REQD, 2 PER LOAD UNIT). INSTALL THROUGH FORK TINE OPENINGS OF TWO LATERALLY ADJACENT CONTAINERS IN THE TOP LAYER, AS SHOWN. STRAPS SHOULD BE POSITIONED AS FAR APART AS THE FORK TINE OPENINGS PERMIT.
- ⑥ SEAL FOR 1-1/4" STRAPPING (24 REQD, 2 PER STRAP). CRIMP EACH SEAL WITH TWO PAIR OF CRIMPS. SEE GENERAL NOTE "M" ON PAGE 2 AND "END-OVER-END LAP JOINT DETAILS" ON PAGE 13.
- ⑦ STRAPPING BOARD, 2" X 6" X 6'-7" (4 REQD).
- ⑧ HOLD-DOWN STRAP, 2" X .050" OR .044" X 27'-6" LONG STEEL STRAPPING (4 REQD). INSTALL EACH STRAP FROM TWO 13'-9" LONG PIECES. STAPLE TO STRAPPING BOARD, PIECE MARKED ⑦, W/2 STAPLES. SEE GENERAL NOTE "M" ON PAGE 2.
- ⑨ SEAL FOR 2" STRAPPING (24 REQD, 6 PER STRAP). CRIMP EACH SEAL WITH TWO PAIR OF CRIMPS, EXCEPT THOSE USED TO SECURE THE PADS, PIECES MARKED ⑩. SEE "HOLD-DOWN STRAP ANCHORING DETAILS" AND "END-OVER-END LAP JOINT DETAILS" ON PAGE 13.
- ⑩ PAD, 2" X .050" OR .044" X 18" LONG STEEL STRAPPING (8 REQD). POSITION UNDER ANCHORING FACILITY AND SEAL TO HOLD-DOWN STRAP, PIECE MARKED ⑧. ALT: STAKE POCKET PROTECTOR (16 REQD). USE TWO UNDER EACH ANCHORING FACILITY WITH A HOLD-DOWN STRAP. SEE "HOLD-DOWN STRAP ANCHORING DETAILS" ON PAGE 13.
- ⑪ ANTI-CHAFING NEUTRAL BARRIER MATERIAL (AS REQD). POSITION UNDER ALL STRAPS AT POINTS OF CONTACT WITH THE CONTAINER, EXCEPT FORK TINE OPENINGS.

SPECIAL NOTES:

1. A 16-CONTAINER LOAD IS SHOWN ON A 40'-0" LONG BY 8'-0" WIDE FLATBED TRAILER. SHORTER AND/OR LONGER TRAILERS MAY BE USED FOR SHIPMENT OF A 16-CONTAINER LOAD.
2. IF DESIRED, AND IF THE CAPACITY OF THE FORKLIFT TRUCK PERMITS, TWO, THREE, OR FOUR CONTAINERS MAY BE STACKED AND UNITIZED WITH STEEL STRAPS, AS SPECIFIED, PRIOR TO PLACEMENT ON THE TRAILER.
3. THE DEPICTED PROCEDURES ALSO APPLY TO TWO AND THREE LAYER LOADS. THE HOLD-DOWN STRAPS WILL BE 24'-0" FOR THREE LAYER (2 WIDE) LOADS AND 21'-0" FOR TWO LAYER (2 WIDE) LOADS.

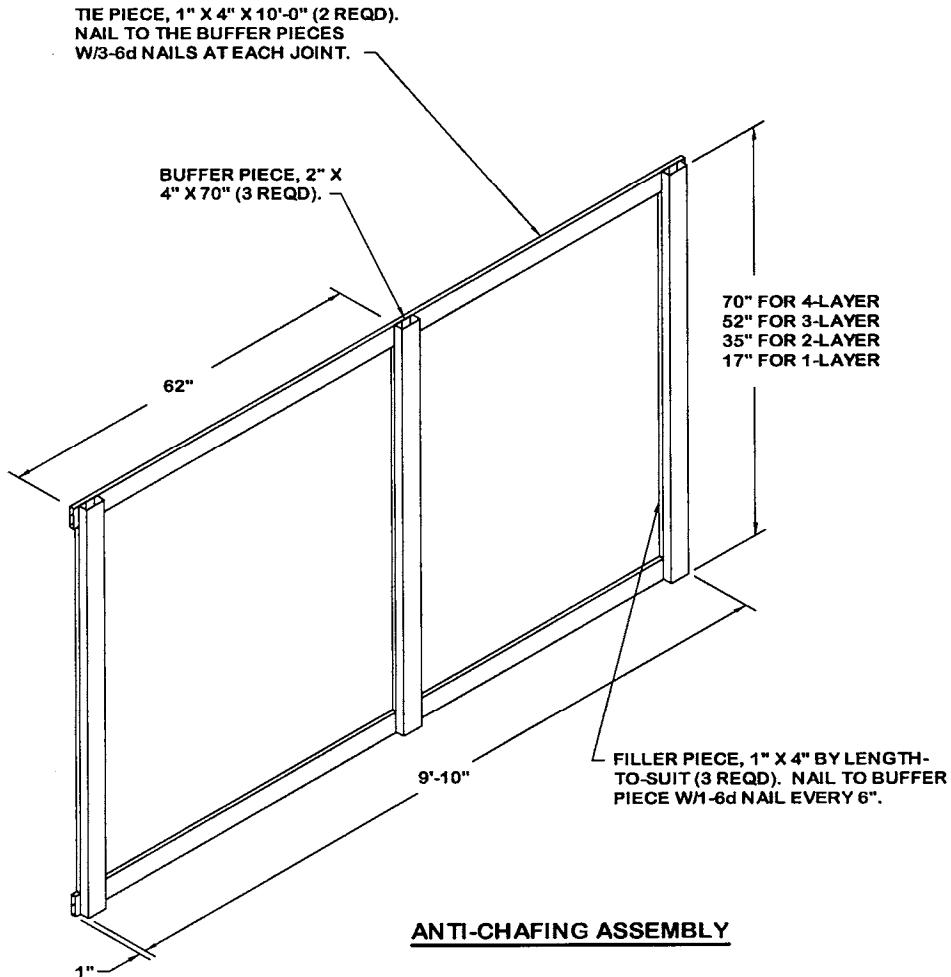

ANTI-CHAFING ASSEMBLY

BILL OF MATERIAL		
LUMBER	LINEAR FEET	BOARD FEET
1" X 4"	72	24
2" X 4"	35	24
2" X 6"	115	115
2" X 8"	20	27
NAILS	NO. REQD	POUNDS
6d (2")	102	3/4
10d (3")	140	2-1/4
20d (4")	24	1
1-1/4" STEEL STRAPPING	----- 200' REQD	----- 28-3/4 LBS
2" STEEL STRAPPING	----- 122' REQD	----- 40-3/4 LBS
SEAL FOR 1-1/4" STRAPPING	----- 24 REQD	----- 1-1/4 LBS
SEAL FOR 2" STRAPPING	----- 24 REQD	----- 5 LBS
STAPLE FOR 2" STRAPPING	----- 8 REQD	----- NIL
ANTI-CHAFING MATERIAL	----- AS REQD	----- NIL

LOAD AS SHOWN

ITEM	QUANTITY	WEIGHT (APPROX)
CONTAINER	----- 16	----- 30,608 LBS
DUNNAGE	-----	----- 460 LBS

TOTAL WEIGHT ----- 31,068 LBS (APPROX)

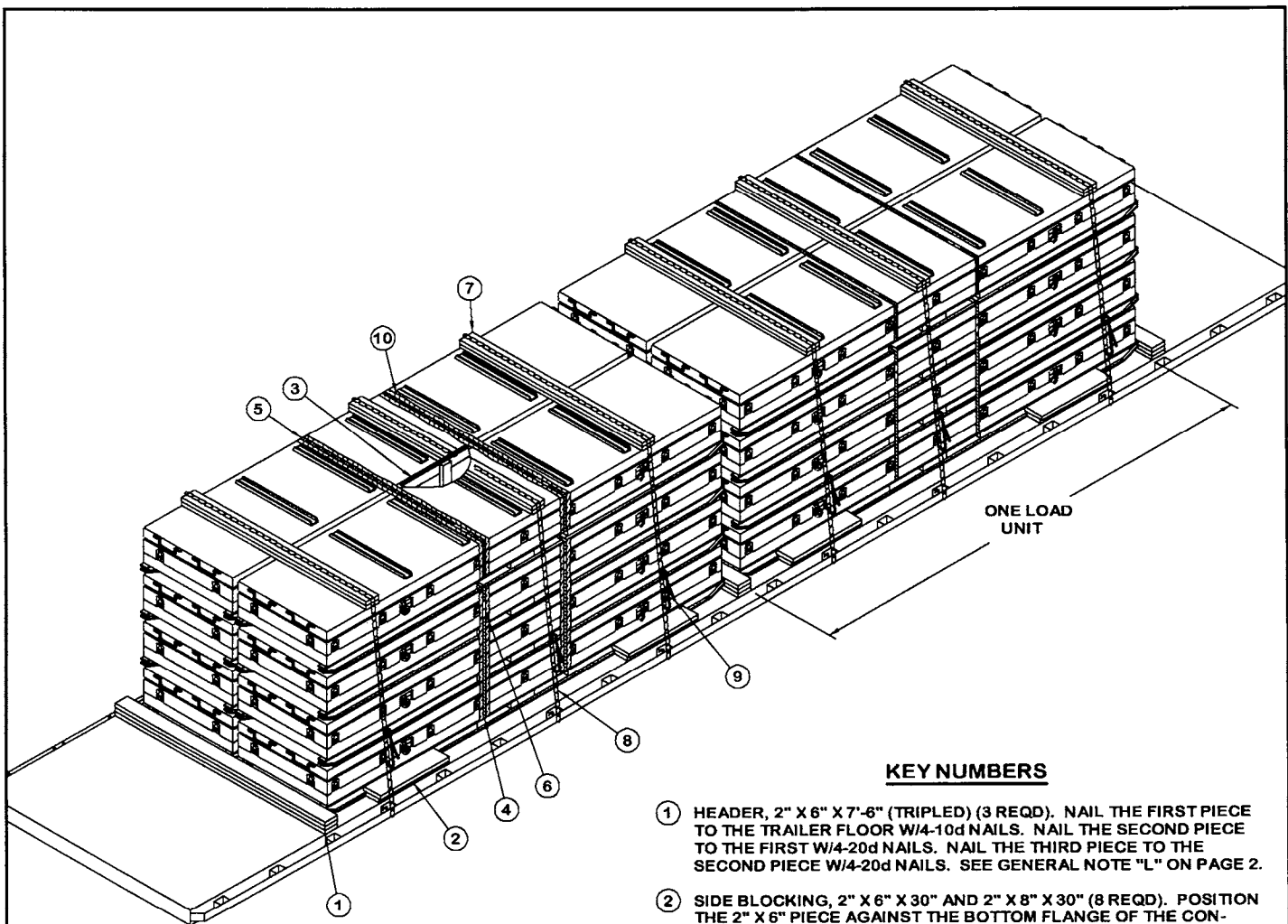

ISOMETRIC VIEW

KEY NUMBERS

- ① HEADER, 2" X 6" X 7'-6" (TRIPLED) (3 REQD). NAIL THE FIRST PIECE TO THE TRAILER FLOOR W/4-10d NAILS. NAIL THE SECOND PIECE TO THE FIRST W/4-20d NAILS. NAIL THE THIRD PIECE TO THE SECOND PIECE W/4-20d NAILS. SEE GENERAL NOTE "L" ON PAGE 2.
- ② SIDE BLOCKING, 2" X 6" X 30" AND 2" X 8" X 30" (8 REQD). POSITION THE 2" X 6" PIECE AGAINST THE BOTTOM FLANGE OF THE CONTAINER SKID AND NAIL TO THE TRAILER FLOOR W/8-10d NAILS. POSITION THE 2" X 8" PIECE ON TOP OF THE 2" X 6" PIECE AND AGAINST THE WEB OF THE CONTAINER SKID. NAIL TO THE 2" X 6" PIECE W/8-10d NAILS. SEE THE SIDE BLOCKING DETAIL ON PAGE 13.
- ③ ANTI-CHAFING ASSEMBLY (2 REQD). SEE THE DETAIL ON PAGE 5.
- ④ STACK UNITIZING STRAP, 1-1/4" X .035" OR .031" X 16'-6" LONG STEEL STRAPPING (8 REQD, 2 PER STACK). INSTALL THROUGH FORK TINE OPENINGS OF UPPER AND LOWER CONTAINERS. STRAPS SHOULD BE POSITIONED AS FAR APART AS THE FORK TINE OPENINGS PERMIT. SEE SPECIAL NOTE 2 ON PAGE 5.
- ⑤ BUNDLING STRAP, 1-1/4" X .035" OR .031" X 17'-0" LONG STEEL STRAPPING (4 REQD, 2 PER LOAD UNIT). INSTALL THROUGH FORK TINE OPENINGS OF TWO LATERALLY ADJACENT CONTAINERS IN THE TOP LAYER, AS SHOWN. STRAPS SHOULD BE POSITIONED AS FAR APART AS THE FORK TINE OPENINGS PERMIT.
- ⑥ SEAL FOR 1-1/4" STRAPPING (24 REQD, 2 PER STRAP). CRIMP EACH SEAL WITH TWO PAIR OF CRIMPS. SEE GENERAL NOTE "M" ON PAGE 2 AND "END-OVER-END LAP JOINT DETAILS" ON PAGE 13.
- ⑦ CHAIN BOARD, 2" X 6" X 6'-7" (DOUBLED) (6 REQD). LAMINATE W/1-10d NAIL EVERY 8".
- ⑧ CHAIN, BINDING, 5/16" GRADE 70 BY A LENGTH TO SUIT (6 REQD). POSITION AS SHOWN ABOVE, FASTENING THE CHAIN GRABHOOKS TO THE TRAILER STAKE POCKETS. SEE THE "SPECIAL PROVISIONS FOR CHAIN TIEDOWN" ON PAGE 7.
- ⑨ LOAD BINDER, 5/16", OVERCENTER TYPE (6 REQD, 1 PER CHAIN). WIRE TIE HANDLE TO PREVENT OPENING DURING TRANSPORT. FASTEN THE TENSIONED CHAIN, PIECE MARKED ⑧, TO THE CHAIN BOARD, PIECE MARKED ⑦, W/1-20d NAIL AT EACH END, BENDING OVER TO FORM A LOOP AROUND THE CHAIN LINK. SEE THE "SPECIAL PROVISIONS FOR CHAIN TIEDOWN" ON PAGE 7.
- ⑩ ANTI-CHAFING NEUTRAL BARRIER MATERIAL (AS REQD). POSITION UNDER ALL STRAPS AT POINTS OF CONTACT WITH THE CONTAINER, EXCEPT FORK TINE OPENINGS.

SPECIAL PROVISIONS FOR CHAIN TIEDOWN

LADING MAY BE SECURED TO THE FLATBED TRAILER BY CARRIER-OWNED CHAINS AND LOAD BINDERS IN LIEU OF SPECIFIED STRAPPING, PROVIDED THE FOLLOWING CONDITIONS ARE MET.

1. ONLY CHAINS AND LOAD BINDERS OF GOOD QUALITY WILL BE USED. ALL CHAINS AND LOAD BINDERS SHALL CONFORM TO THE NATIONAL ASSOCIATION OF CHAIN MANUFACTURER'S WELDED CHAIN SPECIFICATION ADOPTED NOVEMBER 1975.
2. ALL CHAINS SHALL BE MARKED AS PRESCRIBED BY THE NATIONAL ASSOCIATION OF CHAIN MANUFACTURER'S WELDED CHAIN SPECIFICATION ADOPTED NOVEMBER 1975. AT LEAST ONE LINK IN EVERY 36 LINKS SHALL CARRY THE MANUFACTURER'S PERMANENT AND DISTINCTIVE MARK IDENTIFYING THE GRADE OF CHAIN. CHAINS NOT MARKED IN THIS MANNER SHALL NOT BE USED. IN ADDITION TO THE GRADE MARKING, THE CHAIN MAY ALSO CARRY LETTER MARKINGS OR SYMBOLS IDENTIFYING THE CHAIN MANUFACTURER. THE PRESENCE OF THE MANUFACTURER'S IDENTIFICATION MARKING IS NOT MANDATORY.
3. BEFORE AND DURING INSTALLATION, THE CHAINS AND LOAD BINDERS SHALL BE INSPECTED FOR BENT HOOKS, STRETCH, GOUGES, BENT LINKS, WEAR, OR ANY OTHER NOTICEABLE DEFECTS. ANY DEFICIENCY SHALL BE CAUSE FOR REJECTION OF A CHAIN OR LOAD BINDER. CHAINS MUST NOT BE TWISTED DURING INSTALLATION. CAUTION: EXTREME CARE MUST BE EXERCISED WHEN TENSIONING CHAINS TO PREVENT DAMAGE OR PERMANENT DEFORMATION TO THE LADING.
4. CHAIN SIZES AND GRADES APPROVED FOR USE WITH FLATBED TRAILER LOADS ARE AS FOLLOWS:
 - A. 3/8", GRADE 43 HIGH TEST CHAIN
 - B. 5/16", GRADE 70 BINDING CHAIN
 - C. 3/8", GRADE 70 BINDING CHAIN
 - D. 5/16", GRADE 80 ALLOY STEEL CHAIN
 - E. 3/8", GRADE 80 ALLOY STEEL CHAIN
5. THE GRABHOOKS ON THE ENDS OF THE CHAIN MAY BE OF THE FOLLOWING TYPES WITH GRADE MARKINGS AS INDICATED.
 - A. CLEVIS GRABHOOKS, 3/8" SIZE, DO NOT REQUIRE GRADE MARKING. ALLOY GRABHOOKS, 5/16" SIZE, SHALL CARRY THE MANUFACTURER'S GRADE MARK OF 7, 70, OR 700. THE HOOKS SHALL BE USED ON THE APPROPRIATE SIZE CHAIN.
 - B. CLOSED EYE GRABHOOKS, 3/8" AND 5/16" SIZE, MAY BE USED ON THE APPROPRIATE SIZE CHAIN IF THEY ARE A PART OF A CHAIN ASSEMBLY WHICH WAS PROVIDED BY A CHAIN MANUFACTURER, AND THE CHAIN ASSEMBLY CARRIES THE CORRECT GRADE IDENTIFICATION MARKING AS PREVIOUSLY STATED. CLOSED EYE GRABHOOKS THAT FORM A PART OF THE CHAIN ASSEMBLY ARE EXEMPT FROM GRADE MARKINGS.
6. CONNECTING LINKS USED FOR CHAIN REPAIR MUST BE CORRECTLY MARKED AND BE EQUAL TO OR GREATER IN STRENGTH THAN THE CHAIN THEY ARE REPAIRING. CHAINS WITH UNMARKED CONNECTING LINKS SHALL NOT BE USED.
7. CHAIN AND FITTING OF A HIGHER GRADE MAY BE SUBSTITUTED FOR THE GRADES SPECIFIED IN NOTE 4 ABOVE.
8. LOAD BINDERS SHALL BE 5/16" TO 3/8" SIZE AND HAVE A MINIMUM BREAKING STRENGTH OF 16,200 POUNDS (WORKING LOAD LIMIT OF 5,400 POUNDS). OVERCENTER TYPE LOAD BINDERS SHALL BE SAFETY WIRED TO PREVENT ACCIDENTAL OPENING DURING TRANSPORT. LOAD BINDER SIZE SHALL BE COMPATIBLE WITH THE SIZE OF THE CHAIN BEING USED.

SPECIAL NOTES:

1. A 16-CONTAINER LOAD IS SHOWN ON A 40'-0" LONG BY 8'-0" WIDE FLATBED TRAILER. SHORTER AND/OR LONGER TRAILERS MAY BE USED FOR SHIPMENT OF A 16-CONTAINER LOAD.
2. THE PROCEDURE DEPICTED ON PAGES 6 AND 7 CAN BE USED FOR ANY LOADS SHOWN HEREIN. NOTE: THE CHAINS MUST BE ATTACHED TO THE TRAILER STAKE POCKETS AND BE VERTICALLY IN LINE WITH THE CHAIN BOARDS. THE CHAIN BOARDS CAN BE SHIFTED LEFT OR RIGHT BUT MUST NOT BE POSITIONED CLOSER THAN 6" FROM THE CONTAINER ENDS TO PROVIDE FOR VERTICAL ALIGNMENT. IT MAY BE NECESSARY IN SOME LOADS TO SHIFT THE CONTAINERS WITH DUNNAGE TO COMPLY WITH THIS LOADING REQUIREMENT. SEE GENERAL NOTES "P" AND "Q" ON PAGE 2.
3. IF DESIRED, AND IF THE CAPACITY OF THE FORKLIFT TRUCK PERMITS, TWO, THREE, OR FOUR CONTAINERS MAY BE STACKED AND UNITIZED WITH STEEL STRAPS, AS SPECIFIED, PRIOR TO PLACEMENT ON THE TRAILER.

BILL OF MATERIAL		
LUMBER	LINEAR FEET	BOARD FEET
1" X 4"	72	24
2" X 4"	35	24
2" X 6"	167	167
2" X 8"	20	27
NAILS	NO. REQD	POUNDS
6d (2")	102	3/4
10d (3")	200	2-1/4
20d (4")	36	1-1/2
1-1/4" STEEL STRAPPING ----- 200' REQD ----- 28-3/4 LBS		
SEAL FOR 1-1/4" STRAPPING ----- 24 REQD ----- 1-1/4 LBS		
CHAIN, BINDING, 5/16" ----- 132' REQD ----- 158-1/2 LBS		
BINDER, LOAD ----- 6 REQD ----- 36 LBS		
ANTI-CHAFING MATERIAL ----- AS REQD ----- NIL		

LOAD AS SHOWN

ITEM	QUANTITY	WEIGHT (APPROX)
CONTAINER	16	30,608 LBS
DUNNAGE		713 LBS

TOTAL WEIGHT ----- 31,321 LBS (APPROX)

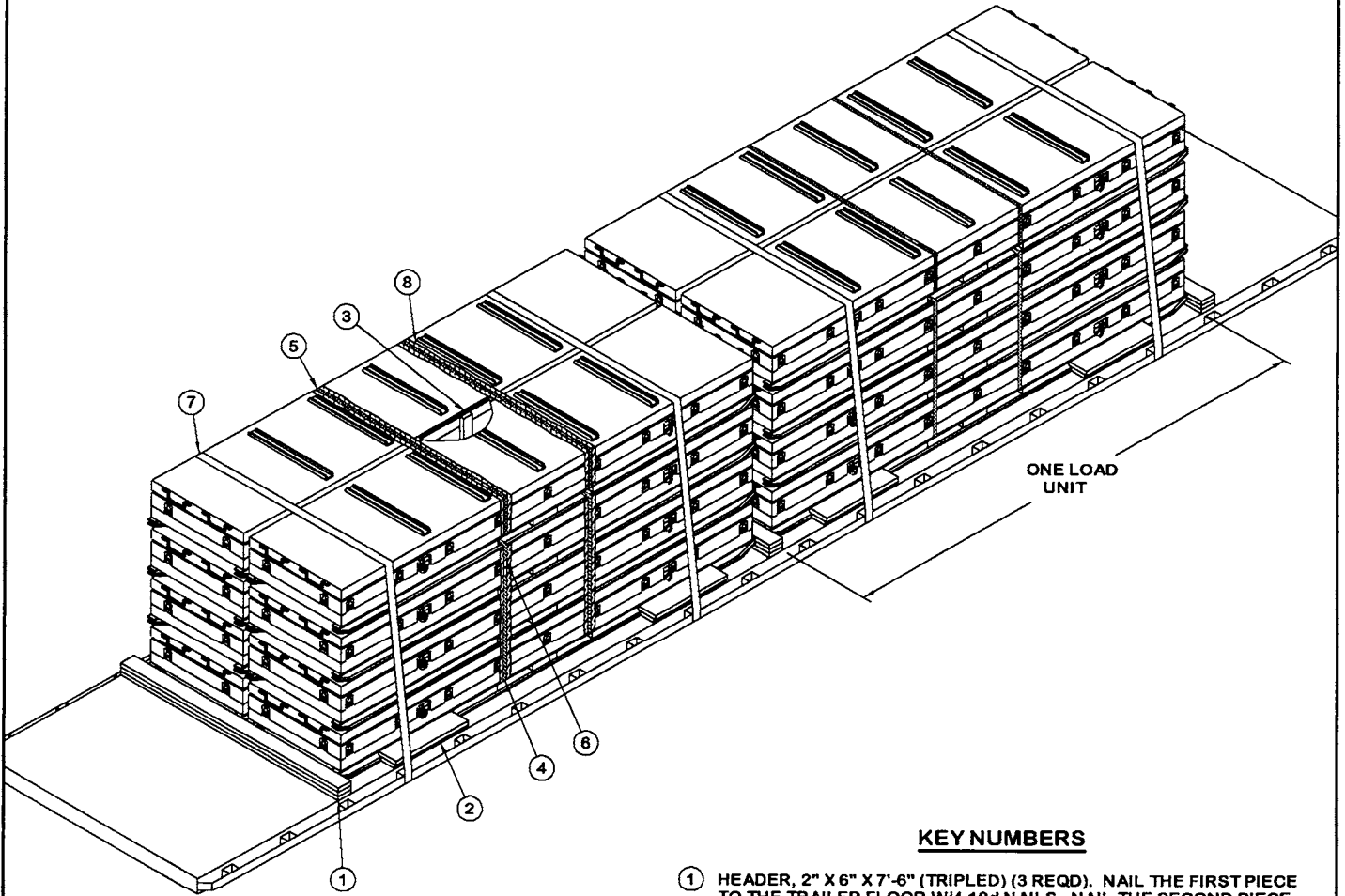

ISOMETRIC VIEW

KEY NUMBERS

- ① HEADER, 2" X 6" X 7'-6" (TRIPLED) (3 REQD). NAIL THE FIRST PIECE TO THE TRAILER FLOOR W/4-10d NAILS. NAIL THE SECOND PIECE TO THE FIRST W/4-20d NAILS. NAIL THE THIRD PIECE TO THE SECOND PIECE W/4-20d NAILS. SEE GENERAL NOTE "L" ON PAGE 2.
- ② SIDE BLOCKING, 2" X 6" X 30" AND 2" X 8" X 30" (8 REQD). POSITION THE 2" X 6" PIECE AGAINST THE BOTTOM FLANGE OF THE CONTAINER SKID AND NAIL TO THE TRAILER FLOOR W/8-10d NAILS. POSITION THE 2" X 8" PIECE ON TOP OF THE 2" X 6" PIECE AND AGAINST THE WEB OF THE CONTAINER SKID. NAIL TO THE 2" X 6" PIECE W/8-10d NAILS. SEE THE SIDE BLOCKING DETAIL ON PAGE 13.
- ③ ANTI-CHAFING ASSEMBLY (2 REQD). SEE THE DETAIL ON PAGE 5.
- ④ STACK UNITIZING STRAP, 1-1/4" X .035" OR .031" X 16'-6" LONG STEEL STRAPPING (8 REQD, 2 PER STACK). INSTALL THROUGH FORK TINE OPENINGS OF UPPER AND LOWER CONTAINERS. STRAPS SHOULD BE POSITIONED AS FAR APART AS THE FORK TINE OPENINGS PERMIT. SEE SPECIAL NOTE 2 ON PAGE 5.
- ⑤ BUNDLING STRAP, 1-1/4" X .035" OR .031" X 17'-0" LONG STEEL STRAPPING (4 REQD, 2 PER LOAD UNIT). INSTALL THROUGH FORK TINE OPENINGS OF TWO LATERALLY ADJACENT CONTAINERS IN THE TOP LAYER, AS SHOWN. STRAPS SHOULD BE POSITIONED AS FAR APART AS THE FORK TINE OPENINGS PERMIT.
- ⑥ SEAL FOR 1-1/4" STRAPPING (24 REQD, 2 PER STRAP). CRIMP EACH SEAL WITH TWO PAIR OF CRIMPS. SEE GENERAL NOTE "M" ON PAGE 2 AND "END-OVER-END LAP JOINT DETAILS" ON PAGE 13.
- ⑦ WEB STRAP ASSEMBLY (4 REQD, 2 PER LOAD UNIT). POSITION TO EXTEND FROM A WINCH ON ONE SIDE OF THE TRAILER, OVER THE CONTAINERS, TO AN ATTACHMENT POINT ON THE OPPOSITE SIDE. SEE THE "SPECIAL PROVISIONS FOR WEB STRAP TIEDOWN" ON PAGE 9.
- ⑧ ANTI-CHAFING NEUTRAL BARRIER MATERIAL (AS REQD). POSITION UNDER ALL STEEL STRAPS AT POINTS OF CONTACT WITH THE CONTAINER, EXCEPT FORK TINE OPENINGS.

SPECIAL PROVISIONS FOR WEB STRAP TIEDOWN

LADING MAY BE SECURED TO A FLATBED TRAILER BY WEB STRAP ASSEMBLIES IN LIEU OF STEEL STRAPPING OR CHAINS AND LOAD BINDERS, PROVIDED THE FOLLOWING CONDITIONS ARE MET.

1. ONLY WEB STRAPS OF GOOD QUALITY WILL BE USED. ALL WEB STRAPS AND ASSOCIATED HARDWARE SHALL CONFORM TO THE WEB SLING & TIEDOWN ASSOCIATION RECOMMENDED STANDARD SPECIFICATION FOR SYNTHETIC WEB TIEDOWNS, FIRST PUBLISHED IN 1991.
2. ALL WEB STRAP TIEDOWN ASSEMBLIES SHALL BE PERMANENTLY LABELED WITHIN 18" OF ONE END TO SHOW:
 - A. NAME OR TRADEMARK OF MANUFACTURER
 - B. WORKING LOAD LIMIT (WLL)
 - C. DATE OF MANUFACTURE (MONTH AND YEAR)
3. WEB STRAP ASSEMBLY MINIMUM BREAKING STRENGTH WILL BE AT LEAST THREE TIMES THE WLL MARKED ON THE STRAP.
4. THE TOTAL MINIMUM BREAKING STRENGTH (MBS) OF THE STRAPS USED TO RESTRAIN AMMUNITION ITEMS WILL BE AT LEAST 1-1/2 TIMES THE TOTAL WEIGHT OF THE ITEMS, WITH A MINIMUM OF TWO STRAPS POSITIONED OVER EACH LOAD UNIT ON A TRAILER. WRITTEN PROOF OF THE MBS OF THE STRAPS SHALL BE PROVIDED BY THE CARRIER TO THE SHIPPING ACTIVITY IF REQUESTED.
5. CARRIERS MUST COMPLY WITH ALL FEDERAL, STATE, AND LOCAL REGULATIONS APPLICABLE TO CARGO RESTRAINT USING WEB STRAPS.
6. WHEN USING STRAPS AND WINCHES FOR CARGO RESTRAINT, THE STRAPS WILL BE TENSIONED UNTIL TIGHT WITHOUT CAUSING DAMAGE TO THE CARGO. ONLY WINCH BARS WILL BE USED FOR OPERATING THE STRAP WINCHES.
7. BEFORE AND DURING INSTALLATION, THE WEB STRAP ASSEMBLIES SHALL BE INSPECTED FOR DEFECTS. STRAPS HAVING ANY OF THE FOLLOWING DEFECTS WILL NOT BE USED FOR THE RESTRAINT OF ANY AMMUNITION LOAD, WITH THE EXCEPTION OF ONE WITH FRAYED ENDS. A STRAP HAVING FRAYED ENDS CAN BE USED IF THE FRAYED END IS TRIMMED AND MELTED WITH HEAT OR FLAME UNTIL ALL STRANDS ARE SEIZED.
 - A. STRAP ASSEMBLY HARDWARE: SHALL BE INSPECTED FOR BENT HOOKS, GOUGES, CORROSION, SIGNS OF REPAIR, BENT RATCHETS OR WINCHES, WEAR, OR ANY OTHER NOTICEABLE DEFECTS.
 - B. STRAP WEBBING: SHALL BE INSPECTED FOR KNOTS, EXCESSIVE ABRASIVE WEAR, TEARS, PUNCTURES, CUTS, ACID OR CAUSTIC BURNS, BROKEN STITCHES, FRAYED ENDS, OIL OR GREASE SPOTS EXCEEDING 6 SQUARE INCHES, BLEACHING OF COLOR, INCREASED STIFFNESS, SPLICES, VISIBLE WEAR INDICATOR THREADS, OR ANY OTHER NOTICEABLE DEFECTS.
8. RATCHET HANDLES MUST BE IN THE LOCKED POSITION AND/OR WINCH LOCKING DEVICES MUST BE FULLY SEATED IN THE TEETH OF THE WINCH.
9. IF THE WINCHES BEING USED ARE THE REMOVABLE TYPE HAVING BOLTS FOR ATTACHMENT TO THE TRAILER, CARE MUST BE EXERCISED WHEN ATTACHING THE WINCHES TO THE TRAILER. IF EXCESSIVE FORCE IS EXERTED ON THE BOLT DURING TENSIONING, DEFORMATION OF THE WINCH BRACKET MAY OCCUR, AND SUBSEQUENTLY CAUSE FAILURE OF THE WINCH BRACKET DURING TRANSPORT. WINCHES MUST BE FASTENED TO THE TRAILER WITH A MINIMUM OF TWO BOLTS.

(CONTINUED AT RIGHT)

BILL OF MATERIAL		
LUMBER	LINEAR FEET	BOARD FEET
1" X 4"	72	24
2" X 4"	35	24
2" X 6"	88	88
2" X 8"	20	27
NAILS	NO. REQD	POUNDS
6d (2")	102	3/4
10d (3")	140	2-1/4
20d (4")	24	1
1-1/4" STEEL STRAPPING ----- 200' REQD ----- 28-3/4 LBS		
SEAL FOR 1-1/4" STRAPPING --- 24 REQD ----- 1-1/4 LBS		
WEB STRAP ASSEMBLIES ----- 4 REQD ----- 4 REQD		
ANTI-CHAFING MATERIAL ----- AS REQD ----- NIL		

SPECIAL NOTES:

1. A 16-CONTAINER LOAD IS SHOWN ON A 40'-0" LONG BY 8'-0" WIDE FLATBED TRAILER. SHORTER AND/OR LONGER TRAILERS MAY BE USED FOR SHIPMENT OF A 16-CONTAINER LOAD.
2. IF DESIRED, AND IF THE CAPACITY OF THE FORKLIFT TRUCK PERMITS, TWO, THREE, OR FOUR CONTAINERS MAY BE STACKED AND UNITIZED WITH STEEL STRAPS, AS SPECIFIED, PRIOR TO PLACEMENT ON THE TRAILER.

(SPECIAL PROVISIONS FOR WEB STRAP TIEDOWN CONTINUED)

10. DRIVERS MUST BE INSTRUCTED TO PERIODICALLY CHECK THE TIGHTNESS OF THE WEB STRAP ASSEMBLIES AND RE-TIGHTEN, IF NECESSARY.
11. IF PROVIDED ON OR WITH THE WEB STRAP ASSEMBLIES, SCUFF SLEEVES/WEB PROTECTORS WILL BE USED WHEREVER THE STRAP PASSES OVER A SHARP CORNER OR IRREGULAR SURFACE. IF NOT PROVIDED, ANTI-CHAFING MATERIAL OF A SUITABLE THICKNESS WILL BE USED TO INSURE THAT THE STRAP WEBBING IS NOT DAMAGED DURING TRANSPORT OF THE LOAD.
12. THE HARDWARE FITTING OF THE TIEDOWN ASSEMBLIES MUST BE ATTACHED TO THE TRAILER IN SUCH A MANNER THAT THEY WILL REMAIN IN PLACE IF SLACK DEVELOPS IN THE STRAP DURING TRANSPORT.

LOAD AS SHOWN

ITEM	QUANTITY	WEIGHT (APPROX)
CONTAINER -----	16 -----	30,608 LBS
DUNNAGE -----	-----	360 LBS
TOTAL WEIGHT -----		30,968 LBS (APPROX)

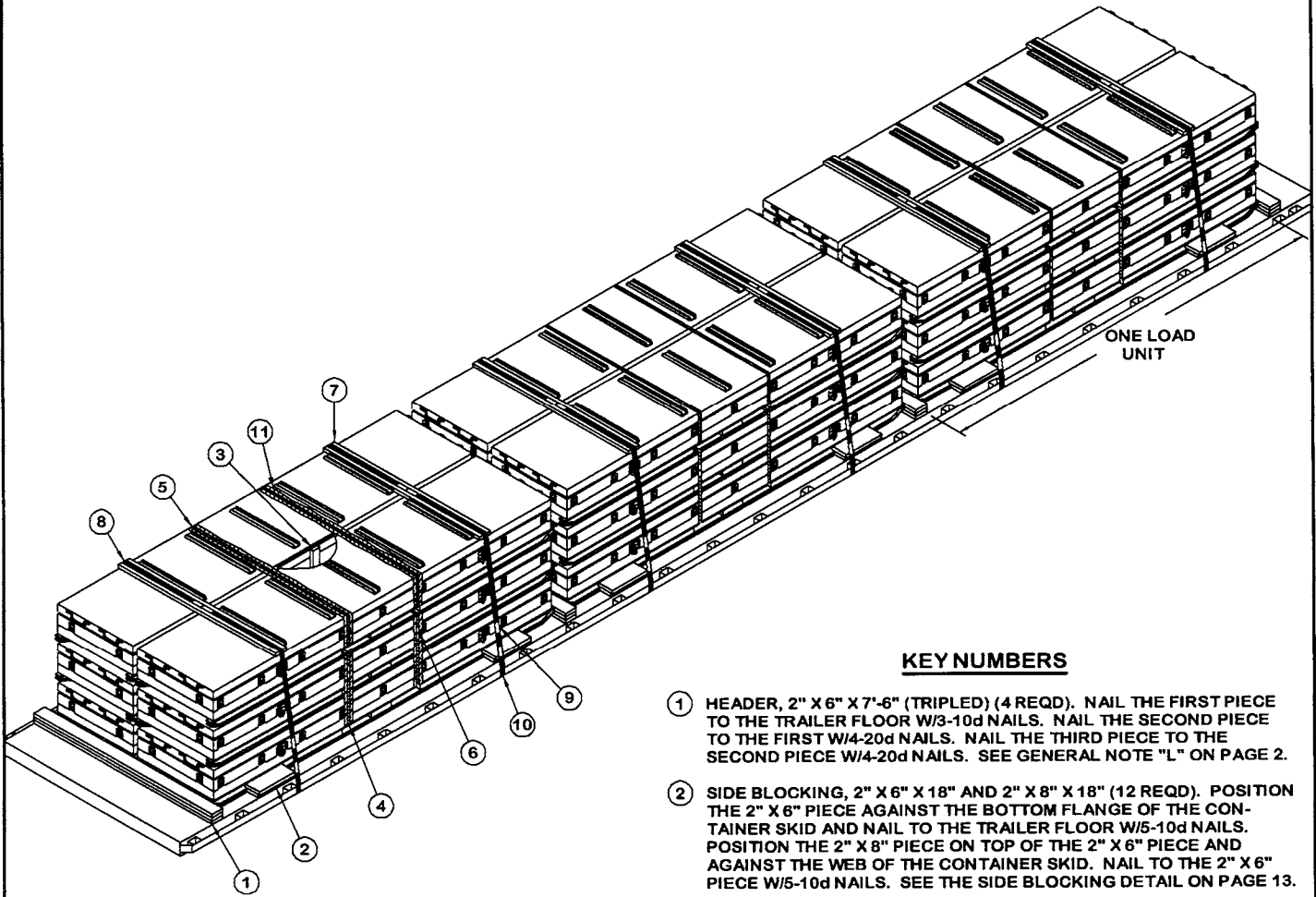

ISOMETRIC VIEW

KEY NUMBERS

- ① HEADER, 2" X 6" X 7'-6" (TRIPLED) (4 REQD). NAIL THE FIRST PIECE TO THE TRAILER FLOOR W/3-10d NAILS. NAIL THE SECOND PIECE TO THE FIRST W/4-20d NAILS. NAIL THE THIRD PIECE TO THE SECOND PIECE W/4-20d NAILS. SEE GENERAL NOTE "L" ON PAGE 2.
- ② SIDE BLOCKING, 2" X 6" X 18" AND 2" X 8" X 18" (12 REQD). POSITION THE 2" X 6" PIECE AGAINST THE BOTTOM FLANGE OF THE CONTAINER SKID AND NAIL TO THE TRAILER FLOOR W/5-10d NAILS. POSITION THE 2" X 8" PIECE ON TOP OF THE 2" X 6" PIECE AND AGAINST THE WEB OF THE CONTAINER SKID. NAIL TO THE 2" X 6" PIECE W/5-10d NAILS. SEE THE SIDE BLOCKING DETAIL ON PAGE 13.
- ③ ANTI-CHAFING ASSEMBLY (3 REQD). SEE THE DETAIL ON PAGE 5.
- ④ STACK UNITIZING STRAP, 1-1/4" X .035" OR .031" X 13'-6" LONG STEEL STRAPPING (12 REQD, 2 PER STACK). INSTALL THROUGH FORK TINE OPENINGS OF UPPER AND LOWER CONTAINERS. STRAPS SHOULD BE POSITIONED AS FAR APART AS THE FORK TINE OPENINGS PERMIT. SEE SPECIAL NOTE 2 ON PAGE 5.
- ⑤ BUNDLING STRAP, 1-1/4" X .035" OR .031" X 17'-0" LONG STEEL STRAPPING (6 REQD, 2 PER LOAD UNIT). INSTALL THROUGH FORK TINE OPENINGS OF TWO LATERALLY ADJACENT CONTAINERS IN THE TOP LAYER, AS SHOWN. STRAPS SHOULD BE POSITIONED AS FAR APART AS THE FORK TINE OPENINGS PERMIT.
- ⑥ SEAL FOR 1-1/4" STRAPPING (36 REQD, 2 PER STRAP). CRIMP EACH SEAL WITH TWO PAIR OF CRIMPS. SEE GENERAL NOTE "M" ON PAGE 2 AND "END-OVER-END LAP JOINT DETAILS" ON PAGE 13.
- ⑦ STRAPPING BOARD, 2" X 6" X 6'-7" (6 REQD).
- ⑧ HOLD-DOWN STRAP, 2" X .050" OR .044" X 24'-6" LONG STEEL STRAPPING (6 REQD). INSTALL EACH STRAP FROM TWO 12'-3" LONG PIECES. STAPLE TO STRAPPING BOARD, PIECE MARKED ⑦, W/2-STAPLES. SEE GENERAL NOTE "M" ON PAGE 2.
- ⑨ SEAL FOR 2" STRAPPING (36 REQD, 6 PER STRAP). CRIMP EACH SEAL WITH TWO PAIR OF CRIMPS, EXCEPT THOSE USED TO SECURE THE PADS, PIECES MARKED ⑩. SEE "HOLD-DOWN STRAP ANCHORING DETAILS" AND "END-OVER-END LAP JOINT DETAILS" ON PAGE 13.
- ⑩ PAD, 2" X .050" OR .044" X 18" LONG STEEL STRAPPING (12 REQD). POSITION UNDER ANCHORING FACILITY AND SEAL TO HOLD-DOWN STRAP, PIECE MARKED ⑧. ALT: STAKE POCKET PROTECTOR (24 REQD). USE TWO UNDER EACH ANCHORING FACILITY WITH A HOLD-DOWN STRAP. SEE "HOLD-DOWN STRAP ANCHORING DETAILS" ON PAGE 13.
- ⑪ ANTI-CHAFING NEUTRAL BARRIER MATERIAL (AS REQD). POSITION UNDER ALL STRAPS AT POINTS OF CONTACT WITH THE CONTAINER, EXCEPT FORK TINE OPENINGS.

SPECIAL NOTES:

1. AN 18-CONTAINER LOAD IS SHOWN ON A 48'-0" LONG BY 8'-0" WIDE FLATBED TRAILER. SHORTER AND/OR LONGER TRAILERS MAY BE USED FOR SHIPMENT OF AN 18-CONTAINER LOAD.
2. IF DESIRED, AND IF THE CAPACITY OF THE FORKLIFT TRUCK PERMITS, TWO OR THREE CONTAINERS MAY BE STACKED AND UNITIZED WITH STEEL STRAPS, AS SPECIFIED, PRIOR TO PLACEMENT ON THE TRAILER.
3. THE DEPICTED PROCEDURES ALSO APPLY TO TWO LAYER LOADS. THE HOLD-DOWN STRAPS WILL BE 21'-0" FOR TWO LAYER (2 WIDE) LOADS.

BILL OF MATERIAL

LUMBER	LINEAR FEET	BOARD FEET
1" X 4"	94	32
2" X 4"	39	26
2" X 6"	148	148
2" X 8"	18	24
NAILS	NO. REQD	POUNDS
6d (2")	126	3/4
10d (3")	140	2-1/4
20d (4")	28	1
1-1/4" STEEL STRAPPING ----- 264' REQD ----- 37-3/4 LBS		
2" STEEL STRAPPING ----- 165' REQD ----- 55 LBS		
SEAL FOR 1-1/4" STRAPPING ---- 36 REQD ----- 1-3/4 LBS		
SEAL FOR 2" STRAPPING ----- 36 REQD ----- 7-1/4 LBS		
STAPLE FOR 2" STRAPPING ----- 12 REQD ----- NIL		
ANTI-CHAFING MATERIAL ----- AS REQD ----- NIL		

LOAD AS SHOWN

ITEM	QUANTITY	WEIGHT (APPROX)
CONTAINER	18	34,434 LBS
DUNNAGE		566 LBS

TOTAL WEIGHT ----- 35,000 LBS (APPROX)

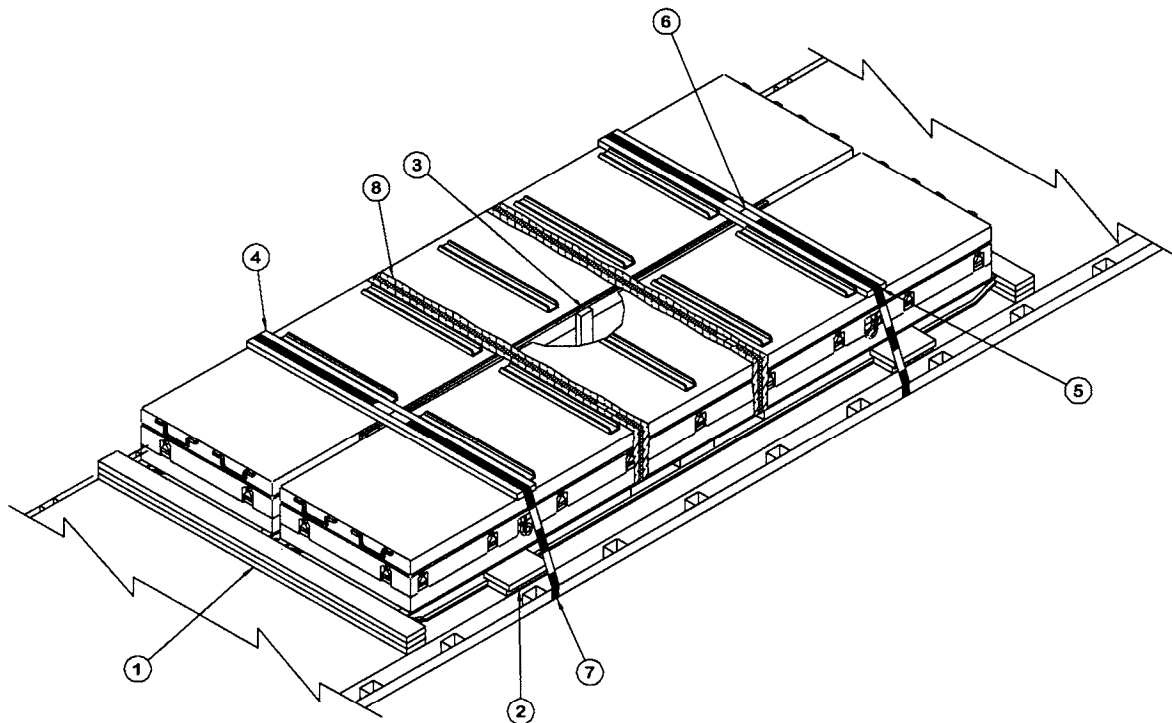

ISOMETRIC VIEW

SPECIAL NOTES:

1. A 2-CONTAINER LOAD IS SHOWN, HOWEVER, THE DEPICTED PROCEDURES CAN ALSO BE USED FOR THE SHIPMENT OF A 1-CONTAINER LOAD BY MODIFYING THE LOAD AS FOLLOWS:
 - A. OMIT PIECES MARKED ③, ⑤, ⑥, AND ⑩ AND CENTER CONTAINER ON TRAILER.
 - B. USE PIECES MARKED ②, ⑧, AND ⑨ AS SPECIFIED.
 - C. REDUCE LENGTH OF THE TWO HEADERS, PIECES MARKED ①, TO 42".
 - D. REDUCE LENGTH OF THE TWO STRAPPING BOARDS, PIECES MARKED ④, TO 38".
 - E. REDUCE LENGTH OF THE TWO HOLD-DOWN STRAPS, PIECES MARKED ⑦, TO 11'-0".
2. REFER TO "SPECIAL PROVISIONS FOR CHAIN TIEDOWN" ON PAGE 7 FOR THE USE OF CHAINS IN LIEU OF STEEL STRAPPING.
3. REFER TO "SPECIAL PROVISIONS FOR WEB STRAP TIEDOWN" ON PAGE 9 FOR THE USE OF WEB STRAPS IN LIEU OF STEEL STRAPPING.

KEY NUMBERS

- ① HEADER, 2" X 6" X 7'-6" (TRIPLED) (2 REQD). NAIL THE FIRST PIECE TO THE TRAILER FLOOR W/3-10d NAILS. NAIL THE SECOND PIECE TO THE FIRST W/3-20d NAILS. NAIL THE THIRD PIECE TO THE SECOND W/3-20d NAILS. SEE GENERAL NOTE "L" ON PAGE 2.
- ② SIDE BLOCKING, 2" X 6" X 12" AND 2" X 8" X 12" (4 REQD). POSITION THE 2" X 6" PIECE AGAINST THE BOTTOM FLANGE OF THE CONTAINER SKID AND NAIL TO THE TRAILER FLOOR W/3-10d NAILS. POSITION THE 2" X 8" PIECE ON TOP OF THE 2" X 6" PIECE AND AGAINST THE WEB OF THE CONTAINER SKID. NAIL TO THE 2" X 6" PIECE W/3-10d NAILS. SEE THE SIDE BLOCKING DETAIL ON PAGE 13.
- ③ ANTI-CHAFING ASSEMBLY (1 REQD). SEE THE DETAIL ON PAGE 5.
- ④ STRAPPING BOARD, 2" X 6" X 6'-7" (2 REQD).
- ⑤ BUNDLING STRAP, 1-1/4" X .035" OR .031" X 17'-0" LONG STEEL STRAPPING (2 REQD). INSTALL THROUGH FORK TINE OPENINGS OF TWO LATERALLY ADJACENT CONTAINERS AS SHOWN. STRAPS SHOULD BE POSITIONED AS FAR APART AS THE FORK TINE OPENINGS PERMIT.
- ⑥ SEAL FOR 1-1/4" STRAPPING (4 REQD, 2 PER STRAP). CRIMP EACH SEAL WITH TWO PAIR OF CRIMPS. SEE GENERAL NOTE "M" ON PAGE 2 AND "END-OVER-END LAP JOINT DETAILS" ON PAGE 13.
- ⑦ HOLD-DOWN STRAP, 2" X .050" OR .044" X 18'-6" LONG STEEL STRAPPING (2 REQD). INSTALL EACH STRAP FROM TWO 9'-3" LONG PIECES. STAPLE TO STRAPPING BOARD, PIECE MARKED ④, W/2 STAPLES. SEE GENERAL NOTE "M" ON PAGE 2.
- ⑧ SEAL FOR 2" STRAPPING (12 REQD, 6 PER STRAP). CRIMP EACH SEAL WITH TWO PAIR OF CRIMPS, EXCEPT THOSE USED TO SECURE THE PADS, PIECES MARKED ⑨. SEE "HOLD-DOWN STRAP ANCHORING DETAILS" AND "END-OVER-END LAP JOINT DETAILS" ON PAGE 13.
- ⑨ PAD, 2" X .050" OR .044" X 18" LONG STEEL STRAPPING (4 REQD). POSITION UNDER ANCHORING FACILITY AND SEAL TO HOLD-DOWN STRAP, PIECE MARKED ⑦. ALT: STAKE POCKET PROTECTOR (8 REQD). USE TWO UNDER EACH ANCHORING FACILITY WITH A HOLD-DOWN STRAP. SEE "HOLD-DOWN STRAP ANCHORING DETAILS" ON PAGE 13.
- ⑩ ANTI-CHAFING NEUTRAL BARRIER MATERIAL (AS REQD). POSITION UNDER ALL STRAPS AT POINTS OF CONTACT WITH THE CONTAINER, EXCEPT FORK TINE OPENINGS.

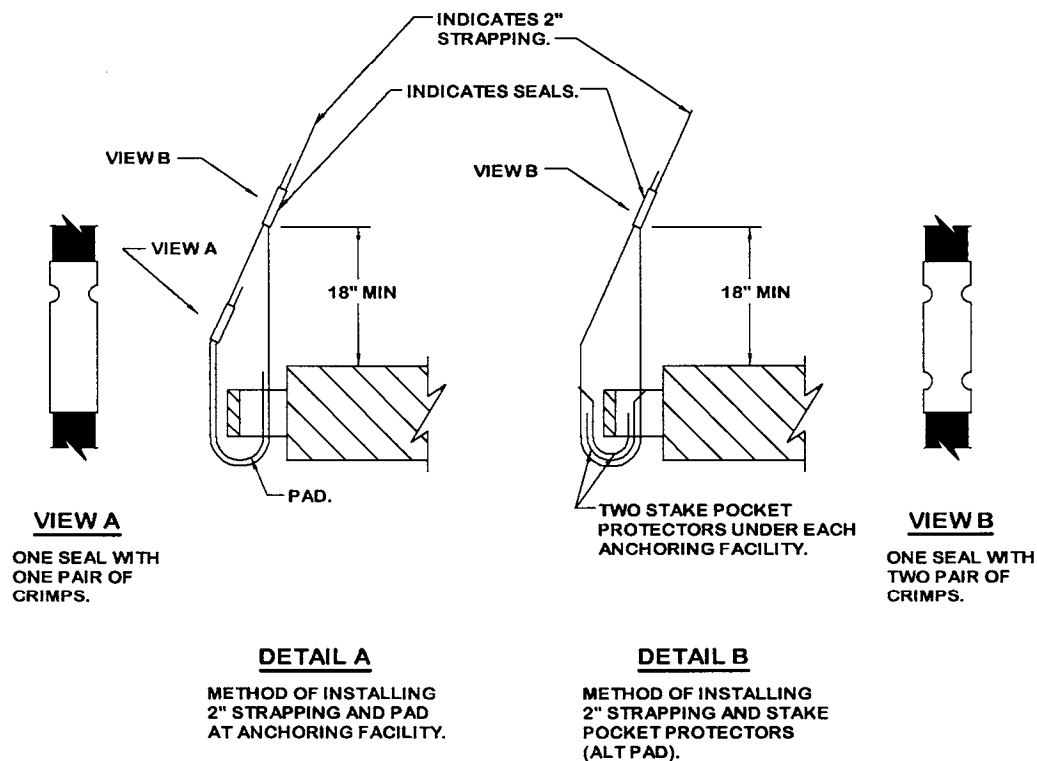

HOLD-DOWN STRAP ANCHORING DETAILS

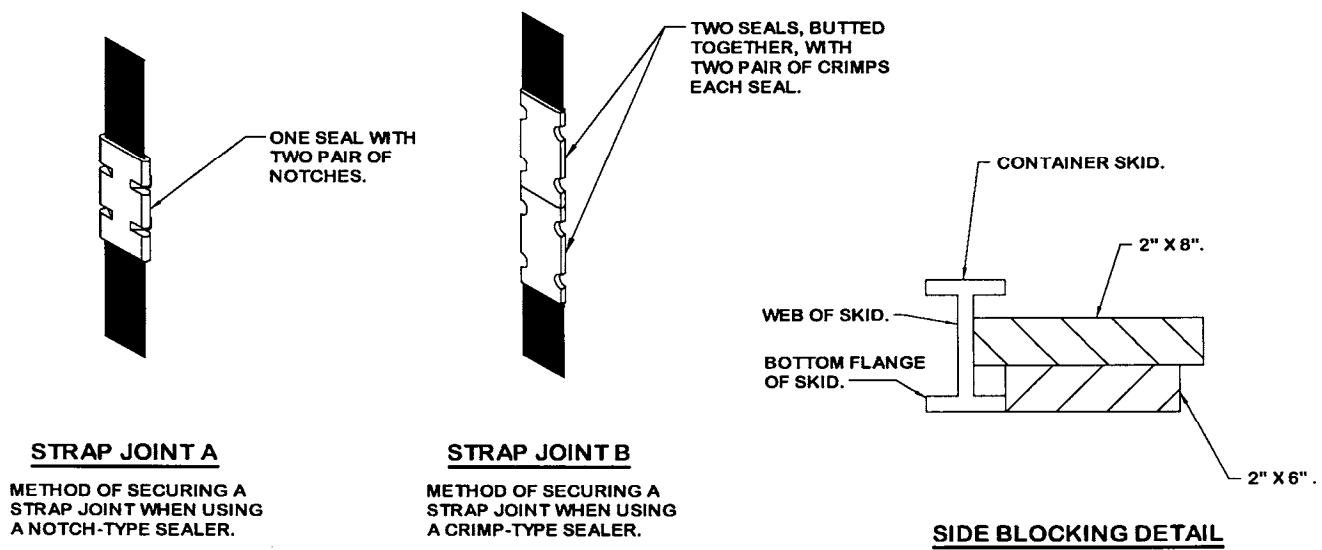

END-OVER-END LAP JOINT DETAILS

**PROVISIONS FOR THE USE OF FIREHOSE IN LIEU
OF CHAIN BOARDS OR STRAPPING BOARDS**

FIRE HOSE THAT IS NO LONGER SUITABLE FOR USE IN FIRE FIGHTING APPLICATIONS CAN BE SUBSTITUTED FOR THE DOUBLED 2" BY 6" WOODEN CHAIN BOARDS OR SINGLE 2" BY 6" STRAPPING BOARDS, AS SPECIFIED HEREIN, PROVIDED THE FOLLOWING CONDITIONS ARE MET.

1. SUBSTITUTION AND APPLICATION GUIDANCE

- A. FIRE HOSE MAY BE USED WHEREVER A CHAIN OR STRAPPING BOARD CONTACTS A RIGID SURFACE OF THE LOAD PROVIDED GOUGING, SCRATCHING, CRACKING, BENDING, CRUSHING, OR OTHER VISIBLE DAMAGE DOES NOT OCCUR TO THE LOAD.
- B. ONE OR MORE SEGMENTS OF FIRE HOSE MAY BE USED TO REPLACE EACH CHAIN OR STRAPPING BOARD PROVIDING LOAD PROTECTION DURING TENSIONING OF TIEDOWNS AND LOAD SHIPMENT; I.E., A CHAIN BOARD NEED NOT BE REPLACED BY A SINGLE SEGMENT OF HOSE, MULTIPLE SEGMENTS MAY BE USED INSTEAD, AS LONG AS THEY ARE SECURELY FASTENED TO THE TIEDOWN. REGARDLESS OF THE NUMBER OF SEGMENTS USED, THE HOSE LENGTH WILL BE SUCH THAT IT EXTENDS AT LEAST 6" BEYOND THE EDGE OF THE LOAD.
- C. FIRE HOSE CANNOT BE USED IN PLACE OF A PURCHASE BOARD ON A LOAD CONSISTING OF MORE THAN TWO PALLETS OR CONTAINERS ACROSS THE WIDTH OF THE TRAILER. THE FIRE HOSE CAN BE APPLIED TO THE OUTER STACKS, HOWEVER, A PURCHASE BOARD ASSEMBLY WILL STILL BE REQUIRED TO PROVIDE VERTICAL HOLD-DOWN ON THE CENTER STACK(S).

2. ACCEPTABLE FIRE HOSE

- A. FIRE HOSE TO BE USED WILL BE A RUBBER LINED SINGLE OR DOUBLE JACKETED TYPE; I.E., IT MUST HAVE A RUBBER LINING INSIDE A SINGLE OR DOUBLED FABRIC (COTTON, LINEN, ETC.) JACKET.
- B. THE COLLAPSED WIDTH OF THE HOSE MUST BE A MINIMUM OF 2-1/2".
- C. THE HOSE SEGMENTS USED MUST NOT CONTAIN DEFECTS THAT WILL ALLOW DIRECT CONTACT OF THE CHAIN OR LOAD BINDER WITH THE LOAD. THE HOSE THICKNESS MUST ALSO BE OF SUCH A THICKNESS THAT DENTING OR DAMAGE TO THE LOAD DOES NOT OCCUR DURING CHAIN OR STRAP TENSIONING.

3. SECUREMENT TO CHAINS OR STRAPS

- A. THE SEGMENTS OF HOSE USED UNDER EACH CHAIN OR STRAP WILL BE SECURED TO THE CHAIN OR STRAP WITH ONE FASTENER EVERY 12", WITH A MINIMUM OF TWO FASTENERS REQUIRED PER HOSE SEGMENT.
- B. FASTENERS CAN CONSIST OF PLASTIC ELECTRICAL TIES, NO. 14 GAGE WIRE, OR TAPE. REGARDLESS OF THE TYPE OF FASTENING USED, IT MUST PROVIDE A POSITIVE MEANS OF SECUREMENT OF THE HOSE TO THE CHAIN OR STRAP AND MUST NOT DAMAGE THE SURFACE OF THE CONTAINER, PALLET, OR ITEM IT CONTACTS.