

# LOADING AND BRACING (TL & LTL) ON FLATBED TRAILERS OF CBU-87/B AND CBU-89/B CLUSTER BOMBS PACKED IN CNU-327/E SHIPPING AND STORAGE CONTAINER

## INDEX

<u>ITEM</u>	<u>PAGE(S)</u>
GENERAL NOTES AND MATERIAL SPECIFICATIONS - - - - -	2
CONTAINER DETAIL - - - - -	3
16-UNIT LOAD ON A 40'-0" LONG BY 8'-0" WIDE FLATBED TRAILER (STEEL STRAP TIEDOWN METHOD) - - - - -	4, 5
16-UNIT LOAD ON A 40'-0" LONG BY 8'-0" WIDE FLATBED TRAILER (CHAIN TIEDOWN METHOD) - - - - -	6, 7
16-UNIT LOAD ON A 40'-0" LONG BY 8'-0" WIDE FLATBED TRAILER (WEB STRAP TIEDOWN METHOD) - - - - -	8, 9
TYPICAL LTL (2-UNIT LOAD) - - - - -	10
DETAILS - - - - -	5, 11
PROVISIONS FOR THE USE OF FIRE HOSE - - - - -	12

● **CAUTION:** THE OUTLOADING PROCEDURES SHOWN HEREIN ARE ONLY APPLICABLE TO HIGHWAY MOVEMENTS; NOT TRAILER-ON-FLAT CAR MOVEMENTS.

## U.S. ARMY MATERIEL COMMAND DRAWING

APPROVED, U.S. ARMY INDUSTRIAL OPERATIONS COMMAND  	ENGINEER	BASIC	WILLIAM MEYER	<b>DO NOT SCALE</b>				
			REV.	MICHAEL SARDONE	WEBSITE: <a href="http://www.dac.army.mil">HTTP://WWW.DAC.ARMY.MIL</a>			
	TECHNICIAN	BASIC	REV.		<b>JULY 1987</b>			
	DRAFTSMAN	BASIC	REV.		REVISION NO. 3		SEPTEMBER 1998	
APPROVED BY ORDER OF COMMANDING GENERAL, U.S. ARMY MATERIEL COMMAND  DEFENSE AMMUNITION CENTER	TRANSPORTATION ENGINEERING DIVISION		<i>W. P. Freink</i>	SEE THE REVISION LISTING ON PAGE 2				
	VALIDATION ENGINEERING DIVISION		<i>William Ernest</i> TESTED	CLASS	DIVISION	DRAWING	FILE	
	LOGISTICS ENGINEERING OFFICE		<i>William Ernest</i>	19	48	7099	SP11M9	

## GENERAL NOTES

- A. THIS DOCUMENT HAS BEEN PREPARED AND ISSUED IN ACCORDANCE WITH AR 740-1, AND AUGMENTS TM 743-200-1 (CHAPTER 5).
- B. THE OUTLOADING PROCEDURES SPECIFIED IN THIS DRAWING ARE APPLICABLE TO LOADS OF CBU-87/B AND CBU-89/B CLUSTER BOMBS PACKED IN CNU-327/E CONTAINERS. SUBSEQUENT REFERENCE TO CONTAINER HEREIN MEANS THE CONTAINER WITH BOMBS INSTALLED. SEE PAGE 3 FOR DETAIL OF THE CONTAINER.
- C. THE LOADS AS SHOWN HEREIN ARE BASED ON 40'-0" LONG BY 8'-0" WIDE FLATBED TRAILERS. TRAILERS OF OTHER LENGTHS AND WIDTHS MAY BE USED. TRAILERS MUST HAVE WOOD OR WOOD AND METAL FLOORS. TRAILERS HAVING ALL-METAL FLOORS CANNOT BE USED. CAUTION: IF THE TRAILER FLOOR IS EQUIPPED WITH EXPOSED METAL DECKING ABOVE THE BOGIE ASSEMBLY, OR ELSEWHERE, FIELD MEASUREMENTS SHOULD BE MADE TO ENSURE THAT THE METAL DECKING DOES NOT INTERFERE WITH THE PROPER POSITIONING AND NAILING OF THE DUNNAGE AS SPECIFIED BY THE PROCEDURES SHOWN HEREIN.
- D. SELECTION OF A VEHICLE FOR THE TRANSPORT OF THE DESIGNATED ITEM IS THE RESPONSIBILITY OF THE ORIGINATING CARRIER AND THE SHIPPER. ONLY VEHICLES IN ACCORDANCE WITH THE REQUIREMENTS OF THE APPLICABLE REGULATORY DOCUMENTS WILL BE SELECTED FOR USE.
- E. GROSS WEIGHT AND AXLE DISTRIBUTION OF WEIGHT FOR A LOAD WILL BE THE RESPONSIBILITY OF THE CARRIER. THE CARRIER WILL ADVISE THE SHIPPER OF APPLICABLE LOADING REQUIREMENTS, AND THE SHIPPER WILL LOAD ACCORDINGLY.
- F. NOTICE: A SHIPMENT WILL BE POSITIONED ON A TRAILER CONSISTENT WITH STATE WEIGHT LAWS.
- G. OTHER TYPES OF LADING ITEMS MAY BE LOADED ON A TRAILER WHICH IS PARTIALLY LOADED WITH THE DESIGNATED ITEM, PROVIDING THE TOTAL LOAD IS COMPATIBLE, EXISTING DIRECTIVES ARE NOT VIOLATED, AND THE OTHER LADING ITEMS ARE BLOCKED AND BRACED TO EQUAL THE BLOCKING AND BRACING CRITERIA SPECIFIED HEREIN.

(CONTINUED AT RIGHT)

## MATERIAL SPECIFICATIONS

LUMBER - - - - -	SEE TM 743-200-1 (DUNNAGE LUMBER) AND VOLUNTARY PRODUCT STANDARD PS 20.
NAILS - - - - -	ASTM F1667; COMMON STEEL NAIL (NLCMS OR NLCMS).
STRAP, WEB - - - - -	WEB SLING AND TIEDOWN ASSOCIATION RECOMMENDED STANDARD SPECIFICATION FOR SYNTHETIC WEB TIEDOWNS, FIRST PUBLISHED IN 1971.
STRAPPING, STEEL - - -	ASTM D3953; FLAT STRAPPING, TYPE 1, HEAVY DUTY, FINISH A, B (GRADE 2), OR C.
SEAL, STRAP - - - - -	ASTM D3953; CLASS H, FINISH A, B (GRADE 2), OR C; DOUBLE NOTCH TYPE, STYLE I, II, OR IV.
STAKE POCKET PROTECTOR - - - - -	COMMERCIAL GRADE.
STRAP STAPLE - - - - -	COMMERCIAL GRADE.
CHAIN - - - - -	NATIONAL ASSOCIATION OF CHAIN MANUFACTURER'S WELDED CHAIN SPECIFICATION ADOPTED NOVEMBER 1975.
LOAD BINDER - - - - -	FED SPEC GGG-B-325.
WIRE, CARBON STEEL - - -	ASTM A853; ANNEALED AT FINISH, BLACK OXIDE FINISH, .0800" DIA, GRADE 1006 OR BETTER.
ANTI-CHAFING MATERIAL - - - - -	MIL-B-121 (OR EQUAL); NEUTRAL BARRIER MATERIAL.

## (GENERAL NOTES CONTINUED)

- H. CAUTION: REGARDLESS OF THE TYPE OF TRAILER INVOLVED, ONLY THOSE TRAILERS HAVING TIEDOWN ANCHORING FACILITIES WHICH PROVIDE HOLDING STRENGTH EQUAL TO OR GREATER THAN THE STRENGTH OF THE HOLD-DOWN STRAPS OR CHAINS AND WHICH ALIGN NEAR THE INDICATED LOCATIONS FOR THE HOLD-DOWN STRAPS OR CHAINS SHOULD BE USED. IF THE TRAILER ANCHOR DEVICES ARE NOT PROPERLY POSITIONED TO RECEIVE STRAPPING OR CHAINS, AS SHOWN, OR IF THE ANCHOR DEVICES ARE NOT EQUAL TO OR GREATER THAN THE STRENGTH OF THE TIEDOWN STRAPS OR CHAINS, STEEL STRAPS MAY BE APPLIED TO FORM A COMPLETE LOOP WHICH ENCOMPASSES BOTH THE LADING AND THE TRAILER FRAME AND/OR BED. CAUTION: AVOID TRAILER WHEELS, FIFTH WHEEL PLATE CONTROLS AND OTHER APPURTENANCES. USE EDGE PROTECTORS OR PADS ON ALL SHARP EDGES. NEITHER CHAINS NOR WEB STRAPS WILL BE APPLIED TO FORM A COMPLETE LOOP WHICH ENCOMPASSES BOTH THE LADING AND THE TRAILER FRAME AND/OR BED.
- J. A STAGGERED NAILING PATTERN WILL BE USED WHEREVER POSSIBLE WHEN NAILS ARE DRIVEN INTO JOINTS OF DUNNAGE ASSEMBLIES. ALSO, A STAGGERED NAILING PATTERN WILL BE USED WHEN DUNNAGE IS NAILED TO THE FLOOR OF THE TRANSPORTING VEHICLE, OR WHEN LAMINATING DUNNAGE. THE NAILING PATTERN WILL BE ADJUSTED AS REQUIRED SO THAT A NAIL DOES NOT PENETRATE INTO OR NEAR A CRACK BETWEEN FLOOR BOARDS. ADDITIONALLY, THE NAILING PATTERN FOR AN UPPER PIECE OF LAMINATED DUNNAGE WILL BE ADJUSTED AS REQUIRED SO THAT A NAIL FOR THAT PIECE WILL NOT BE DRIVEN THROUGH THE PIECE ONTO OR RIGHT BESIDE A NAIL IN A LOWER PIECE.
- K. WHEN STEEL STRAPPING IS SEALED AT AN END-OVER-END LAP JOINT, A MINIMUM OF ONE SEAL WITH TWO PAIR OF NOTCHES WILL BE USED TO SEAL THE JOINT WHEN A NOTCH-TYPE SEALER IS BEING USED. A MINIMUM OF TWO SEALS, BUTTED TOGETHER WITH TWO PAIR OF CRIMPS PER SEAL WILL BE USED TO SEAL THE JOINT WHEN A CRIMP-TYPE SEALER IS BEING USED. REFER TO THE "STRAP JOINT A" AND "STRAP JOINT B" DETAILS ON PAGE 11 FOR GUIDANCE.
- L. THE TRANSPORTING VEHICLE OPERATOR SHOULD BE INSTRUCTED TO PERIODICALLY INSPECT THE TIEDOWN CHAINS AND LOAD BINDERS DURING TRANSIT AND TIGHTEN IF NECESSARY.
- M. THE NUMBER OF LADING UNITS MAY BE ADJUSTED TO FIT THE SIZE OF THE TRAILER TO BE LOADED OR THE QUANTITY TO BE SHIPPED. THE APPROVED METHODS SHOWN HEREIN MUST BE FOLLOWED AS CLOSELY AS POSSIBLE FOR BLOCKING, BRACING AND STAYING OF THE DESIGNATED ITEM.
- N. DUNNAGE LUMBER SPECIFIED IS OF NOMINAL SIZE. FOR EXAMPLE, 1" X 4" MATERIAL IS ACTUALLY 3/4" THICK BY 3-1/2" WIDE AND 2" X 6" MATERIAL IS ACTUALLY 1-1/2" THICK BY 5-1/2" WIDE.
- O. CONVERSION TO METRIC EQUIVALENTS: DIMENSIONS WITHIN THIS DOCUMENT ARE EXPRESSED IN INCHES, AND WEIGHTS ARE EXPRESSED IN POUNDS. WHEN NECESSARY, THE METRIC EQUIVALENTS MAY BE COMPUTED ON THE BASIS OF ONE INCH EQUALS 25.4MM, AND ONE POUND EQUALS 0.454 KG.
- P. FOR ADDITIONAL GUIDANCE, ATTENTION IS DIRECTED TO THE "SPECIAL NOTES" SECTION WHICH IS IMMEDIATELY ADJACENT TO A DEPICTED OUTLOADING METHOD.

## REVISIONS

REVISION NO. 1, DATED JANUARY 1988, CONSISTS OF:

1. CHANGING ANTI-CHAFING ASSEMBLY DETAIL.
2. CHANGING STRAPPING BOARDS FOR LOADS USING CHAIN TIEDOWNS.

REVISION NO. 2, DATED NOVEMBER 1996, CONSISTS OF:

1. REMOVING BACK-UP CLEATS FROM LOAD DRAWINGS.
2. ADDING WEB STRAP TIEDOWN METHOD.
3. CHANGING SIDE BLOCKING FROM 30" TO 24".
4. UPDATING GENERAL NOTES AND DRAWING FORMAT.
5. ADDING PROVISIONS FOR THE USE OF FIRE HOSE.

REVISION NO. 3, DATED SEPTEMBER 1998, CONSISTS OF:

1. CORRECTING CONTAINER DATA ON PAGE 3.
2. UPDATING GENERAL NOTES AND DRAWING FORMAT.

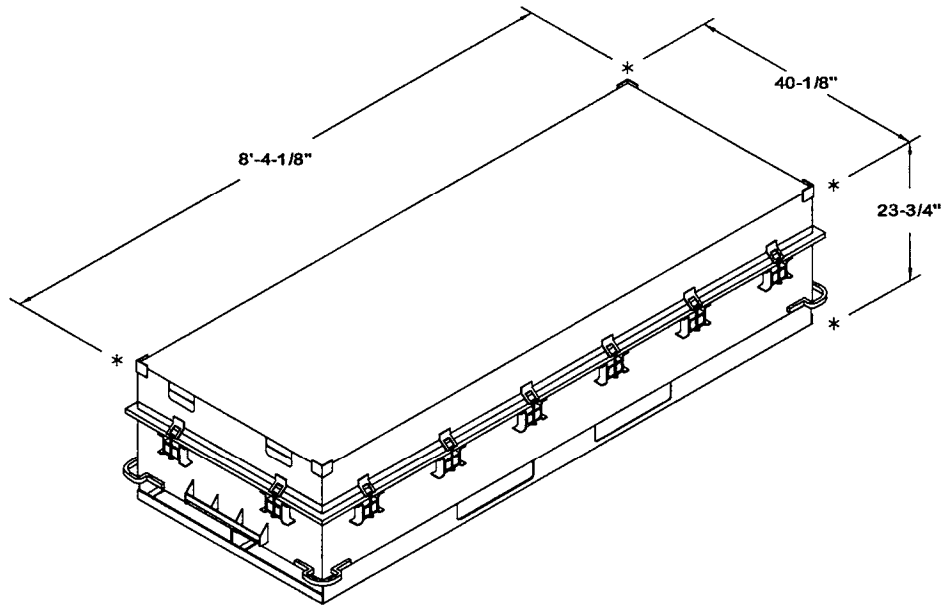

CNU-327/E CONTAINER

GROSS WEIGHT (CBU-87/B) - - - 2,486 POUNDS (APPROX)  
 GROSS WEIGHT (CBU-89/B) - - - 1,886 POUNDS (APPROX)  
 CUBE - - - - - 55.2 CUBIC FEET (APPROX)

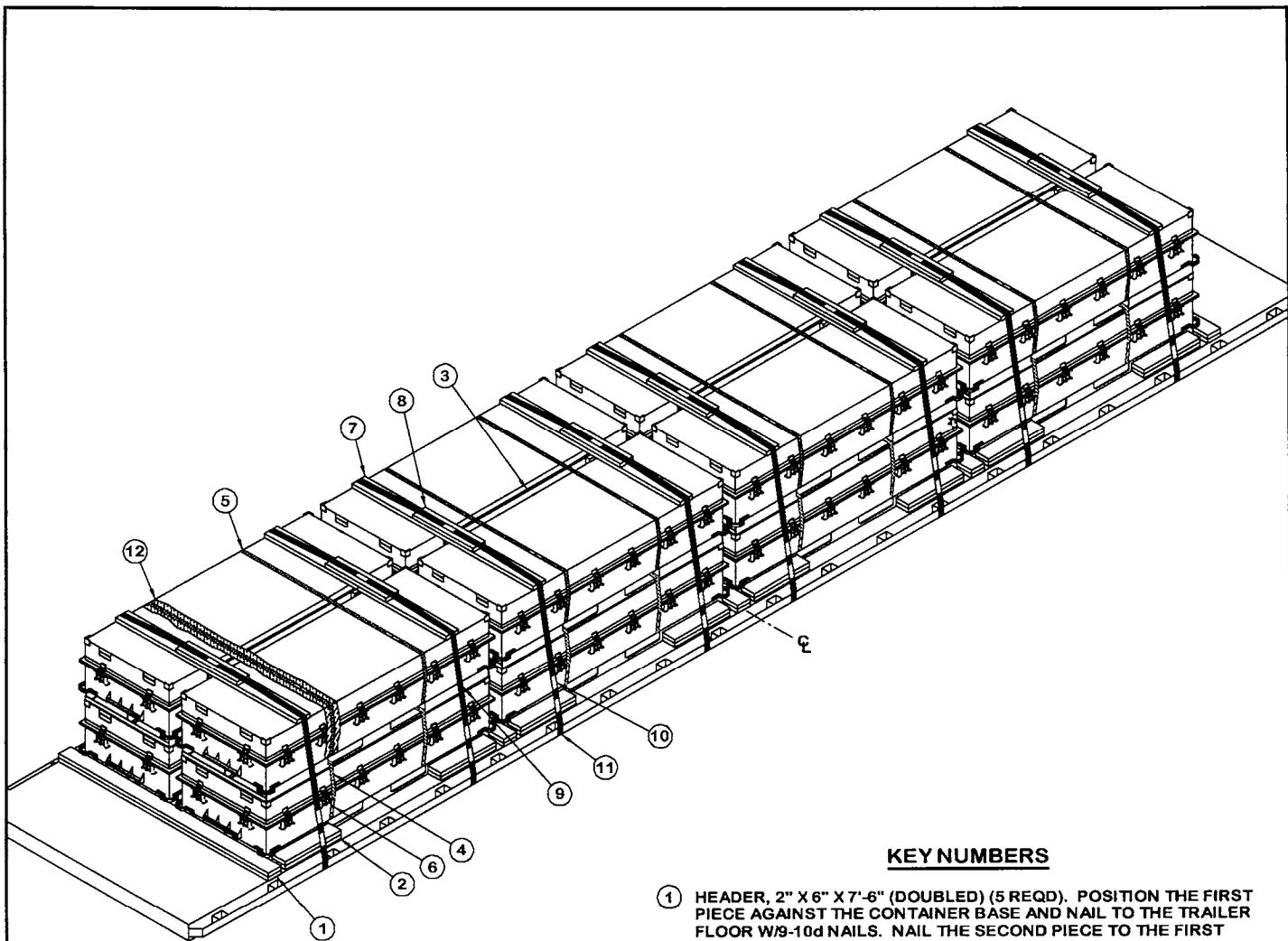

**ISOMETRIC VIEW**

**(KEY NUMBERS CONTINUED)**

- ⑩ SEAL FOR 2" STEEL STRAPPING (40 REQD, 5 PER STRAP). FASTEN PIECE MARKED ⑨ WITH ONE SEAL, CRIMPED WITH TWO PAIR OF NOTCHES AT EACH JOINT, EXCEPT THOSE USED TO SECURE THE PADS, PIECE MARKED ⑪ WHICH REQUIRES ONE SEAL WITH ONE PAIR OF NOTCHES. SEE THE "HOLD-DOWN STRAP ANCHORING" DETAILS ON PAGE 11 AND GENERAL NOTE "K" ON PAGE 2.
- ⑪ PAD, 2" X .050" OR .044" X 18" LONG STEEL STRAPPING (16 REQD). POSITION UNDER THE ANCHORING FACILITY AND SEAL TO THE HOLD-DOWN STRAP, PIECE MARKED ⑨. ALT: STAKE POCKET PROTECTOR (32 REQD). USE TWO UNDER EACH ANCHORING FACILITY WITH ONE HOLD-DOWN STRAP. SEE THE "HOLD-DOWN STRAP ANCHORING" DETAILS ON PAGE 11.
- ⑫ ANTI-CHAFING NEUTRAL BARRIER MATERIAL (AS REQD). POSITION UNDER ALL STRAPS AT POINT OF CONTACT WITH THE CONTAINER, EXCEPT THROUGH FORKLIFT OPENINGS.

**KEY NUMBERS**

- ① HEADER, 2" X 6" X 7'-6" (DOUBLED) (5 REQD). POSITION THE FIRST PIECE AGAINST THE CONTAINER BASE AND NAIL TO THE TRAILER FLOOR W/9-10d NAILS. NAIL THE SECOND PIECE TO THE FIRST W/9-20d NAILS. SEE GENERAL NOTE "J" ON PAGE 2.
- ② SIDE BLOCKING, 2" X 6" X 24" (DOUBLED) (16 REQD). POSITION THE FIRST PIECE AGAINST THE CONTAINER SIDE AS SHOWN AND NAIL W/6-10d NAILS. NAIL THE SECOND PIECE TO THE FIRST IN A LIKE MANNER.
- ③ ANTI-CHAFING ASSEMBLY (4 REQD). SEE THE "ANTI-CHAFING ASSEMBLY" DETAIL ON PAGE 5.
- ④ UNITIZING STRAP, 1-1/4" X .035" OR .031" X 11'-0" LONG STEEL STRAPPING (16 REQD, 2 PER STACK). INSTALL THROUGH THE FORKLIFT OPENINGS OF THE FIRST AND SECOND LAYER CONTAINERS. STRAPS SHOULD BE POSITIONED AS FAR APART AS THE FORKLIFT OPENINGS PERMIT.
- ⑤ BUNDLING STRAP, 1-1/4" X .035" OR .031" X 18'-0" LONG STEEL STRAPPING (8 REQD). INSTALL TO ENIRCLE THROUGH THE FORKLIFT OPENINGS OF THE LATERALLY ADJACENT CONTAINERS IN THE TOP LAYER AS SHOWN ABOVE. STRAPS SHOULD BE POSITIONED AS FAR APART AS THE FORKLIFT OPENINGS PERMIT.
- ⑥ SEAL FOR 1-1/4" STRAPPING (48 REQD, 2 PER STRAP). DOUBLE CRIMP EACH SEAL. SEE GENERAL NOTE "K" ON PAGE 2.
- ⑦ STRAPPING BOARD, 2" X 6" X 6'-6" (8 REQD). POSITION ON TOP OF THE CONTAINERS AS SHOWN ABOVE.
- ⑧ PURCHASE BOARD, 2" X 6" X 26" (8 REQD). CENTER ON THE STRAPPING BOARD, PIECE MARKED ⑦, AND NAIL W/4-10d NAILS.
- ⑨ HOLD-DOWN STRAP, 2" X .050" OR .044" X 18'-0" LONG STEEL STRAPPING (8 REQD). POSITION OVER THE TOP OF THE LOAD AS SHOWN ABOVE AND FASTEN TO THE TRAILER SIDE RAILS AS PER HOLD-DOWN STRAP ANCHORING DETAILS ON PAGE 11. STAPLE TO THE STRAPPING BOARD W/1 STAPLE AT EACH END. SEE GENERAL NOTE "H" ON PAGE 2.

(CONTINUED AT LEFT)

**SPECIAL NOTES:**

1. A 16-UNIT LOAD IS SHOWN ON A 40'-0" LONG BY 8'-0" WIDE FLATBED TRAILER. THE AVAILABLE NAILING SURFACE OF THE TRAILER BED MUST MEASURE AT LEAST 34'-4" LONG. TRAILERS OF OTHER LENGTHS AND WIDTHS MAY ALSO BE USED.
2. IF THE CAPACITY OF MATERIALS HANDLING EQUIPMENT (MHE) IS ADEQUATE, IT IS RECOMMENDED THAT EACH STACK OF TWO CONTAINERS BE UNITIZED PRIOR TO LOADING ON THE FLATBED TRAILER. IF THIS IS NOT POSSIBLE, THEN THE UNITIZING STRAPS MUST BE POSITIONED AS LOADING PROGRESSES.
3. PLACE ANTI-CHAFING NEUTRAL BARRIER MATERIAL UNDER THE HOLD-DOWN STRAPPING AT ALL POINTS OF CONTACT WITH THE CONTAINER AND SECURE TO PREVENT DISLODGMET DURING AND AFTER STRAP APPLICATION. STRIPS OF ANTI-CHAFING MATERIAL MAY BE TAPED OR STRING TIED TO THE CONTAINER OR STRAPPING, OR IT CAN BE FORMED INTO STRAP ENCIRCLING TUBES BY WINDING THE MATERIAL AROUND THE STRAPPING TO FORM A SELF HOLDING UNIT.
4. IF CHAINS AND LOAD BINDERS ARE TO BE USED FOR LOAD SECUREMENT, REFER TO THE PROCEDURES ON PAGES 6 AND 7 FOR GUIDANCE.
5. IF WEB STRAP TIEDOWNS ARE TO BE USED FOR LOAD SECUREMENT, REFER TO THE PROCEDURES ON PAGES 8 AND 9 FOR GUIDANCE.
6. THE LOAD AS SHOWN ON PAGE 4 MAY BE REDUCED BY AN EVEN NUMBER OF UNITS, SUCH AS TWO, FOUR, SIX, OR EIGHT CONTAINERS FROM THE TOP LAYER OF LATERALLY ADJACENT CONTAINERS AS REQUIRED. SEE GENERAL NOTES "E" AND "F" ON PAGE 2.
7. THE DEPICTED PROCEDURES ALSO APPLY TO A SHIPMENT OF CBU-89/B BOMBS IN THE CNU-327/E CONTAINER.

TIE PIECE, 1" X 4" X 66" (2 REQD).  
NAIL TO THE BUFFER PIECES  
W/3-6d NAILS AT EACH JOINT.

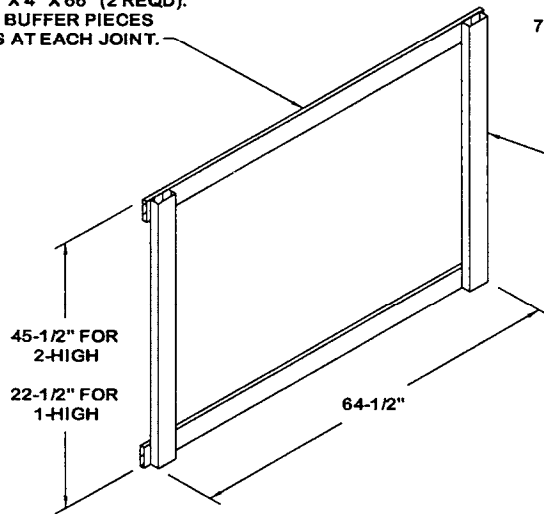

BUFFER PIECE, 2" X 4" X 45-1/2" FOR A 2-HIGH  
LOAD, 22-1/2" FOR A 1-HIGH LOAD (2 REQD).

**ISOMETRIC VIEW**

NOTE: THE BUFFER PIECES MAY BE SHIFTED  
INWARD SLIGHTLY TO AVOID ANY CONTAINER  
OBSTRUCTIONS IF REQUIRED.

BILL OF MATERIAL		
LUMBER	LINEAR FEET	BOARD FEET
1" X 4"	44	15
2" X 4"	31	21
2" X 6"	209	209
NAILS	NO. REQD	POUNDS
6d (2")	48	1/2
10d (3")	269	4-1/4
20d (4")	45	1-3/4
STEEL STRAPPING, 1-1/4"	320' REQD	45-3/4 LBS
STEEL STRAPPING, 2"	168' REQD	56 LBS
SEAL FOR 1-1/4" STRAPPING	48 REQD	2-1/4 LBS
SEAL FOR 2" STRAPPING	40 REQD	8 LBS
ANTI-CHAFING MATERIAL	AS REQD	NIL
STAPLE	16 REQD	NIL

**LOAD AS SHOWN**

ITEM	QUANTITY	WEIGHT (APPROX)
CONTAINER (w/CBU-87/B)	16	39,776 LBS
DUNNAGE		609 LBS
TOTAL WEIGHT		40,385 LBS (APPROX)

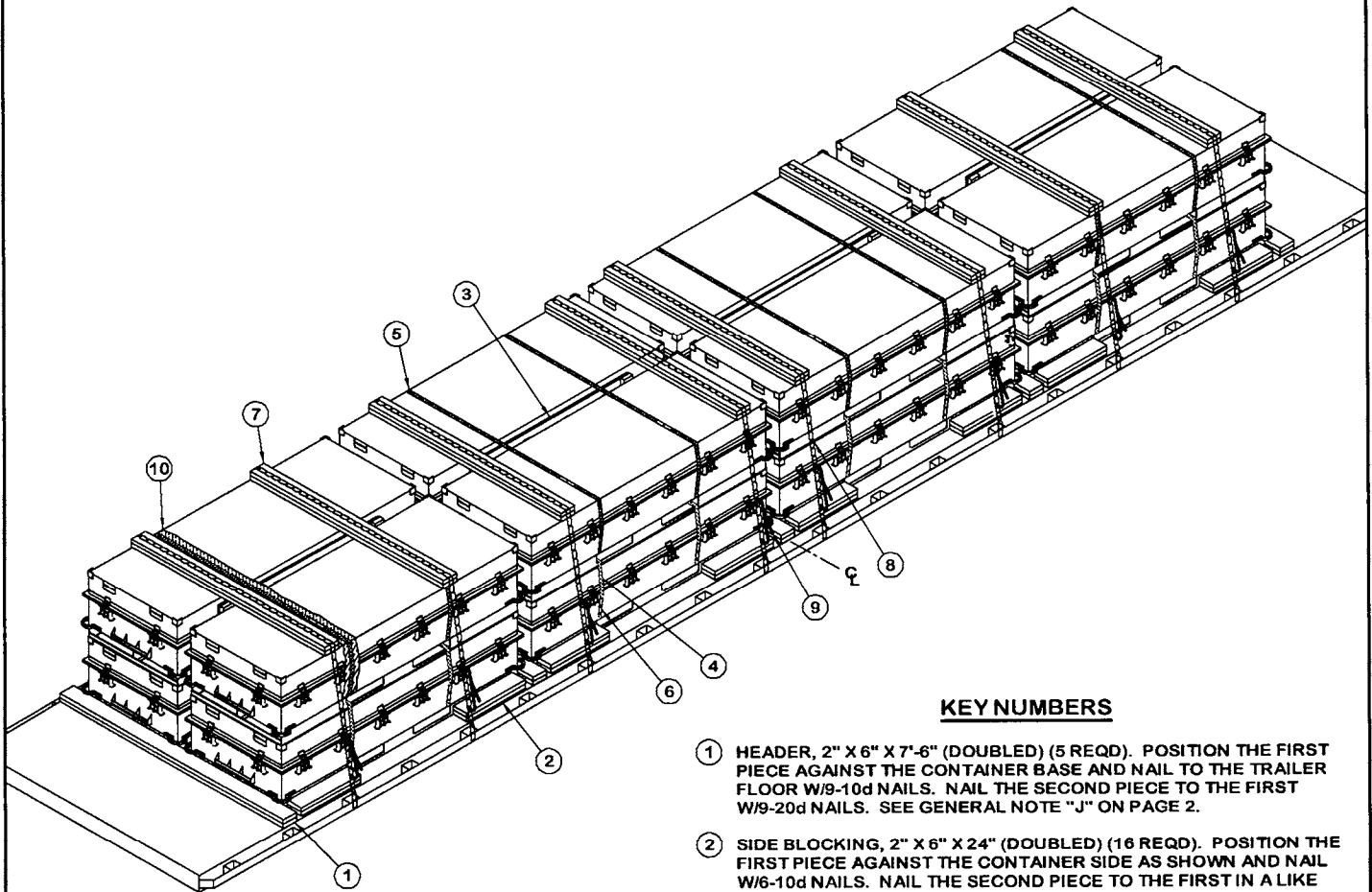

**ISOMETRIC VIEW**

**KEY NUMBERS**

- ① HEADER, 2" X 6" X 7'-6" (DOUBLED) (5 REQD). POSITION THE FIRST PIECE AGAINST THE CONTAINER BASE AND NAIL TO THE TRAILER FLOOR W/9-10d NAILS. NAIL THE SECOND PIECE TO THE FIRST W/9-20d NAILS. SEE GENERAL NOTE "J" ON PAGE 2.
- ② SIDE BLOCKING, 2" X 6" X 24" (DOUBLED) (16 REQD). POSITION THE FIRST PIECE AGAINST THE CONTAINER SIDE AS SHOWN AND NAIL W/6-10d NAILS. NAIL THE SECOND PIECE TO THE FIRST IN A LIKE MANNER.
- ③ ANTI-CHAFING ASSEMBLY (4 REQD). SEE THE "ANTI-CHAFING ASSEMBLY" DETAIL ON PAGE 5.
- ④ UNITIZING STRAP, 1-1/4" X .035" OR .031" X 11'-0" LONG STEEL STRAPPING (16 REQD, 2 PER STACK). INSTALL THROUGH THE FORKLIFT OPENINGS OF THE FIRST AND SECOND LAYER CONTAINERS. STRAPS SHOULD BE POSITIONED AS FAR APART AS THE FORKLIFT OPENINGS PERMIT.
- ⑤ BUNDLING STRAP, 1-1/4" X .035" OR .031" X 18'-0" LONG STEEL STRAPPING (8 REQD). INSTALL TO ENIRCLE THROUGH THE FORKLIFT OPENINGS OF THE LATERALLY ADJACENT CONTAINERS IN THE TOP LAYER AS SHOWN ABOVE. STRAPS SHOULD BE POSITIONED AS FAR APART AS THE FORKLIFT OPENINGS PERMIT.
- ⑥ SEAL FOR 1-1/4" STRAPPING (48 REQD, 2 PER STRAP). DOUBLE CRIMP EACH SEAL. SEE GENERAL NOTE "K" ON PAGE 2.
- ⑦ CHAIN BOARD, 2" X 6" X 6'-6" (DOUBLED)(8 REQD). LAMINATE W/1-10d NAIL EVERY 8". POSITION ON TOP OF THE CONTAINERS AS SHOWN ABOVE. SEE SPECIAL NOTE 8 ON PAGE 7.
- ⑧ CHAIN, BINDING, 5/16", GRADE 70 BY A LENGTH TO SUIT (8 REQD). POSITION AS SHOWN ABOVE, FASTENING THE CHAIN GRABHOOKS TO THE TRAILER STAKE POCKETS. SEE "SPECIAL PROVISIONS FOR CHAIN TIEDOWN" ON PAGE 7.
- ⑨ LOAD BINDER, 5/16", OVER CENTER TYPE (8 REQD, 1 PER CHAIN). WIRE TIE HANDLE TO PREVENT OPENING DURING TRANSPORT. FASTEN THE TENSIONED CHAIN, PIECE MARKED ⑧, TO THE CHAIN BOARD, PIECE MARKED ⑦, W/1-20d NAIL AT EACH END, BENDING OVER TO FORM A LOOP AROUND THE CHAIN LINK. SEE "SPECIAL PROVISIONS FOR CHAIN TIEDOWN" ON PAGE 7.
- ⑩ ANTI-CHAFING NEUTRAL BARRIER MATERIAL (AS REQD). POSITION UNDER ALL STRAPS AT POINT OF CONTACT WITH THE CONTAINER, EXCEPT THROUGH FORKLIFT OPENINGS.

**SPECIAL NOTES:**

1. A 16-UNIT LOAD IS SHOWN ON A 40'-0" LONG BY 8'-0" WIDE FLATBED TRAILER. THE AVAILABLE NAILING SURFACE OF THE TRAILER BED MUST MEASURE AT LEAST 34'-4" LONG. TRAILERS OF OTHER LENGTHS AND WIDTHS MAY ALSO BE USED.
2. IF THE CAPACITY OF MATERIALS HANDLING EQUIPMENT (MHE) IS ADEQUATE, IT IS RECOMMENDED THAT EACH STACK OF TWO CONTAINERS BE UNITIZED PRIOR TO LOADING ON THE FLATBED TRAILER. IF THIS IS NOT POSSIBLE, THEN THE UNITIZING STRAPS MUST BE POSITIONED AS LOADING PROGRESSES.
3. PLACE ANTI-CHAFING NEUTRAL BARRIER MATERIAL UNDER THE HOLD-DOWN STRAPPING AT ALL POINTS OF CONTACT WITH THE CONTAINER AND SECURE TO PREVENT DISLODMENT DURING AND AFTER STRAP APPLICATION. STRIPS OF ANTI-CHAFING MATERIAL MAY BE TAPED OR STRING TIED TO THE CONTAINER OR STRAPPING, OR IT CAN BE FORMED INTO STRAP ENCIRCLING TUBES BY WINDING THE MATERIAL AROUND THE STRAPPING TO FORM A SELF HOLDING UNIT.
4. THE DEPICTED PROCEDURES ALSO APPLY TO A SHIPMENT OF CBU-89/B BOMBS IN THE CNU-327/E CONTAINER.
5. IF STEEL STRAPPING IS TO BE USED FOR LOAD SECUREMENT, REFER TO THE PROCEDURES ON PAGES 6 AND 7 FOR GUIDANCE.
6. IF WEB STRAP TIEDOWNS ARE TO BE USED FOR LOAD SECUREMENT, REFER TO THE PROCEDURES ON PAGES 8 AND 9 FOR GUIDANCE.
7. THE LOAD AS SHOWN ON PAGE 6 MAY BE REDUCED BY AN EVEN NUMBER OF UNITS, SUCH AS TWO, FOUR, SIX, OR EIGHT CONTAINERS FROM THE TOP LAYER OF LATERALLY ADJACENT CONTAINERS AS REQUIRED. SEE GENERAL NOTES "E" AND "F" ON PAGE 2.
8. NOTE: THE CHAINS MUST BE ATTACHED TO THE TRAILER STAKE POCKETS AND VERTICALLY IN LINE WITH THE CHAIN BOARDS. THE CHAIN BOARDS CAN BE SHIFTED LEFT OR RIGHT BUT MUST NOT BE POSITIONED CLOSER THAN 6" FROM THE CONTAINER ENDS TO PROVIDE FOR VERTICAL ALIGNMENT. IT MAY BE NECESSARY IN SOME LOADS TO SHIFT THE CONTAINERS WITH DUNNAGE TO ADHERE WITH THIS LOADING REQUIREMENT. SEE GENERAL NOTES "E" AND "F" ON PAGE 2.

**SPECIAL PROVISIONS FOR CHAIN TIEDOWN**

LADING MAY BE SECURED TO THE FLATBED TRAILER BY CARRIER-OWNED CHAINS AND LOAD BINDERS IN LIEU OF SPECIFIED STRAPPING, PROVIDED THE FOLLOWING CONDITIONS.

1. ONLY CHAINS AND LOAD BINDERS OF GOOD QUALITY WILL BE USED. ALL CHAINS AND LOAD BINDERS SHALL CONFORM TO THE NATIONAL ASSOCIATION OF CHAIN MANUFACTURER'S WELDED CHAIN SPECIFICATION ADOPTED NOVEMBER 1975.
2. ALL CHAINS SHALL BE MARKED AS PRESCRIBED BY THE NATIONAL ASSOCIATION OF CHAIN MANUFACTURER'S WELDED CHAIN SPECIFICATION ADOPTED NOVEMBER 1975. AT LEAST ONE LINK IN EVERY 36 LINKS SHALL CARRY THE MANUFACTURER'S PERMANENT AND DISTINCTIVE MARK IDENTIFYING THE GRADE OF CHAIN. CHAINS NOT MARKED IN THIS MANNER SHALL NOT BE USED. IN ADDITION TO THE GRADE MARKING, THE CHAIN MAY ALSO CARRY LETTER MARKINGS OR SYMBOLS IDENTIFYING THE CHAIN MANUFACTURER. THE PRESENCE OF THE MANUFACTURER'S IDENTIFICATION MARKING IS NOT MANDATORY.
3. BEFORE AND DURING INSTALLATION, THE CHAINS AND LOAD BINDERS SHALL BE INSPECTED FOR BENT HOOKS, STRETCH, GOUGES, BENT LINKS, WEAR, OR ANY OTHER NOTICEABLE DEFECTS. ANY DEFICIENCY SHALL BE CAUSE FOR REJECTION OF A CHAIN OR LOAD BINDER. CHAINS MUST NOT BE TWISTED DURING INSTALLATION. CAUTION: EXTREME CARE MUST BE EXERCISED WHEN TENSIONING CHAINS TO PREVENT DAMAGE OR PERMANENT DEFORMATION TO THE LADING.
4. CHAIN SIZES AND GRADES APPROVED FOR USE WITH FLATBED TRAILER LOADS ARE AS FOLLOWS:
  - A. 3/8", GRADE 43 HIGH TEST CHAIN
  - B. 5/16", GRADE 70 BINDING CHAIN
  - C. 3/8", GRADE 70 BINDING CHAIN
  - D. 5/16", GRADE 80 ALLOY STEEL CHAIN
  - E. 3/8", GRADE 80 ALLOY STEEL CHAIN
5. THE GRABHOOKS ON THE ENDS OF THE CHAIN MAY BE OF THE FOLLOWING TYPES WITH GRADE MARKINGS AS INDICATED.
  - A. CLEVIS GRABHOOKS, 3/8" SIZE, DO NOT REQUIRE GRADE MARKING. ALLOY GRABHOOKS, 5/16" SIZE, SHALL CARRY THE MANUFACTURER'S GRADE MARK OF 7, 70, OR 700. THE HOOKS SHALL BE USED ON THE APPROPRIATE SIZE CHAIN.
  - B. CLOSED EYE GRABHOOKS, 3/8" AND 5/16" SIZE, MAY BE USED ON THE APPROPRIATE SIZE CHAIN IF THEY ARE A PART OF A CHAIN ASSEMBLY WHICH WAS PROVIDED BY A CHAIN MANUFACTURER, AND THE CHAIN ASSEMBLY CARRIES THE CORRECT GRADE IDENTIFICATION MARKING AS PREVIOUSLY STATED. CLOSED EYE GRABHOOKS THAT FORM A PART OF THE CHAIN ASSEMBLY ARE EXEMPT FROM GRADE MARKINGS.
6. CONNECTING LINKS USED FOR CHAIN REPAIR MUST BE CORRECTLY MARKED AND BE EQUAL TO OR GREATER IN STRENGTH THAN THE CHAIN THEY ARE REPAIRING. CHAINS WITH UNMARKED CONNECTING LINKS SHALL NOT BE USED.
7. CHAIN AND FITTING OF A HIGHER GRADE MAY BE SUBSTITUTED FOR THE GRADES SPECIFIED IN NOTE 4 ABOVE.
8. LOAD BINDERS SHALL BE 5/16" TO 3/8" SIZE AND HAVE A MINIMUM BREAKING STRENGTH OF 16,200 POUNDS (WORKING LOAD LIMIT OF 5,400 POUNDS). OVERCENTER TYPE LOAD BINDERS SHALL BE SAFETY WIRED TO PREVENT ACCIDENTAL OPENING DURING TRANSPORT. LOAD BINDER SIZE SHALL BE COMPATIBLE WITH THE SIZE OF THE CHAIN BEING USED.

BILL OF MATERIAL		
LUMBER	LINEAR FEET	BOARD FEET
1" X 4"	44	15
2" X 4"	31	21
2" X 6"	243	243
NAILS	NO. REQD	POUNDS
6d (2")	48	1/2
10d (3")	317	5
20d (4")	45	1-3/4
STEEL STRAPPING, 1-1/4"	-- 320' REQD	-- 45-3/4 LBS
SEAL FOR 1-1/4" STRAPPING	-- 48 REQD	-- 2-1/4 LBS
CHAIN, BINDING, 5/16"	--- 152' REQD	--- 183 LBS
LOAD BINDER	----- 8 REQD	----- 48 LBS
ANTI-CHAFING MATERIAL	----- AS REQD	----- NIL

**LOAD AS SHOWN**

ITEM	QUANTITY	WEIGHT (APPROX)
CONTAINER (w/CBU-87/B)	16	39,776 LBS
DUNNAGE		845 LBS
TOTAL WEIGHT		40,621 LBS (APPROX)

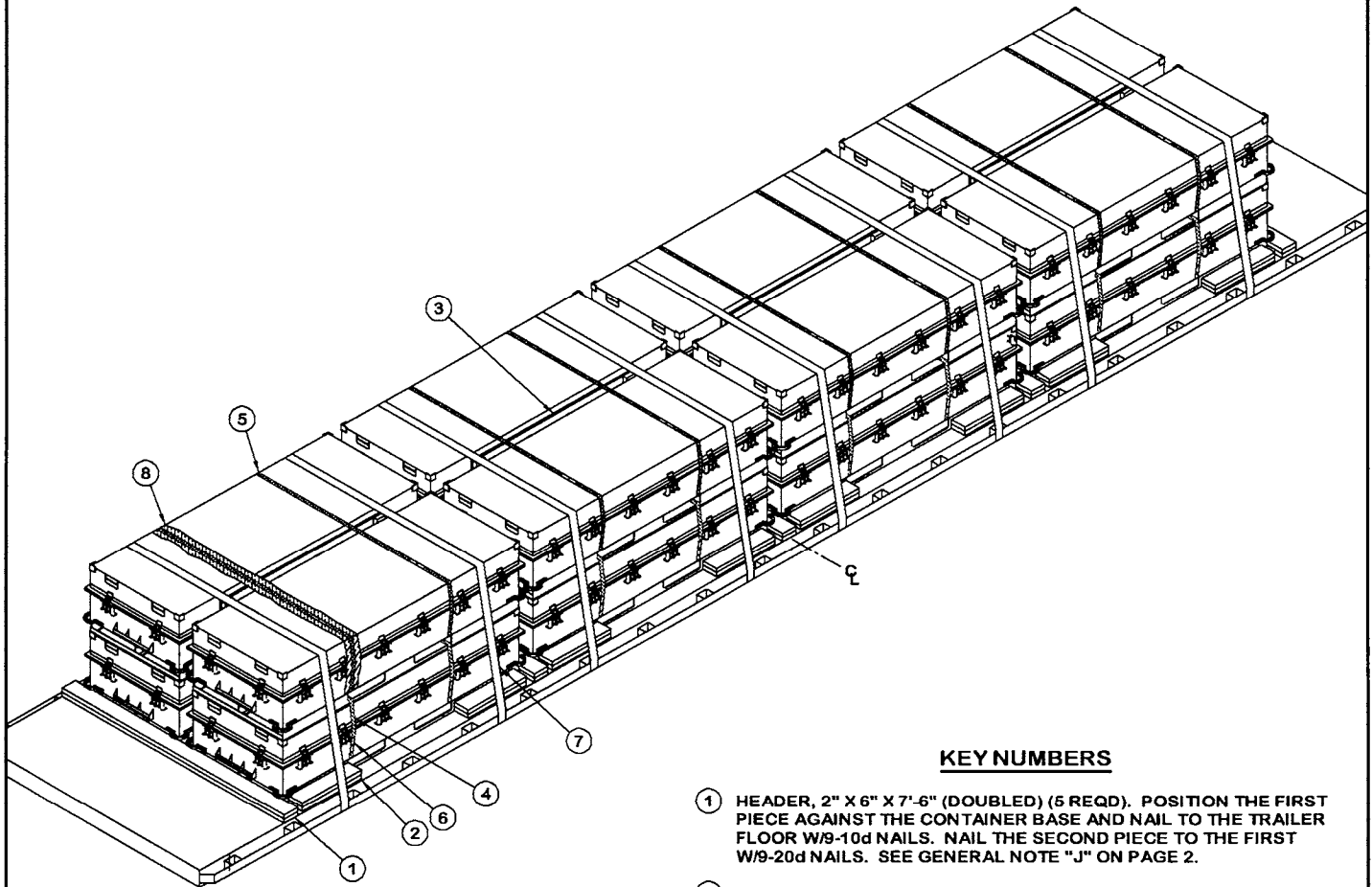

**ISOMETRIC VIEW**

**KEY NUMBERS**

- ① HEADER, 2" X 6" X 7'-6" (DOUBLED) (5 REQD). POSITION THE FIRST PIECE AGAINST THE CONTAINER BASE AND NAIL TO THE TRAILER FLOOR W/9-10d NAILS. NAIL THE SECOND PIECE TO THE FIRST W/9-20d NAILS. SEE GENERAL NOTE "J" ON PAGE 2.
- ② SIDE BLOCKING, 2" X 6" X 24" (DOUBLED) (16 REQD). POSITION THE FIRST PIECE AGAINST THE CONTAINER SIDE AS SHOWN AND NAIL W/6-10d NAILS. NAIL THE SECOND PIECE TO THE FIRST IN A LIKE MANNER.
- ③ ANTI-CHAFING ASSEMBLY (4 REQD). SEE THE "ANTI-CHAFING ASSEMBLY" DETAIL ON PAGE 5.
- ④ UNITIZING STRAP, 1-1/4" X .035" OR .031" X 11'-0" LONG STEEL STRAPPING (16 REQD, 2 PER STACK). INSTALL THROUGH THE FORKLIFT OPENINGS OF THE FIRST AND SECOND LAYER CONTAINERS. STRAPS SHOULD BE POSITIONED AS FAR APART AS THE FORKLIFT OPENINGS PERMIT.
- ⑤ BUNDLING STRAP, 1-1/4" X .035" OR .031" X 18'-0" LONG STEEL STRAPPING (8 REQD). INSTALL TO ENIRCLE THROUGH THE FORKLIFT OPENINGS OF THE LATERALLY ADJACENT CONTAINERS IN THE TOP LAYER AS SHOWN ABOVE. STRAPS SHOULD BE POSITIONED AS FAR APART AS THE FORKLIFT OPENINGS PERMIT.
- ⑥ SEAL FOR 1-1/4" STRAPPING (48 REQD, 2 PER STRAP). DOUBLE CRIMP EACH SEAL. SEE GENERAL NOTE "K" ON PAGE 2.
- ⑦ WEB STRAP ASSEMBLY (8 REQD, 2 PER LOAD UNIT). POSITION TO EXTEND FROM A WINCH ON ONE SIDE OF THE TRAILER, OVER THE CONTAINERS, TO AN ATTACHMENT POINT ON THE OPPOSITE SIDE. SEE THE "SPECIAL PROVISIONS FOR WEB STRAP TIEDOWN" ON PAGE 9.
- ⑧ ANTI-CHAFING NEUTRAL BARRIER MATERIAL (AS REQD). POSITION UNDER ALL STRAPS AT POINT OF CONTACT WITH THE CONTAINER, EXCEPT THROUGH FORKLIFT OPENINGS.



**SPECIAL PROVISIONS FOR WEB STRAP TIEDOWN**

LADING MAY BE SECURED TO A FLATBED TRAILER BY WEB STRAP ASSEMBLIES IN LIEU OF STEEL STRAPPING OR CHAINS AND LOAD BINDERS, PROVIDED THE FOLLOWING CONDITIONS ARE MET.

1. ONLY WEB STRAPS OF GOOD QUALITY WILL BE USED. ALL WEB STRAPS AND ASSOCIATED HARDWARE SHALL CONFORM TO THE WEB SLING & TIEDOWN ASSOCIATION RECOMMENDED STANDARD SPECIFICATION FOR SYNTHETIC WEB TIEDOWNS, FIRST PUBLISHED IN 1991.
2. ALL WEB STRAP TIEDOWN ASSEMBLIES SHALL BE PERMANENTLY LABELED WITHIN 18" OF ONE END TO SHOW:
  - A. NAME OR TRADEMARK OF MANUFACTURER
  - B. WORKING LOAD LIMIT (WLL)
  - C. DATE OF MANUFACTURE (MONTH AND YEAR)
3. WEB STRAP ASSEMBLY MINIMUM BREAKING STRENGTH WILL BE AT LEAST THREE TIMES THE WLL MARKED ON THE STRAP.
4. THE TOTAL MINIMUM BREAKING STRENGTH (MBS) OF THE STRAPS USED TO RESTRAIN AMMUNITION ITEMS WILL BE AT LEAST 1-1/2 TIMES THE TOTAL WEIGHT OF THE ITEMS, WITH A MINIMUM OF TWO STRAPS POSITIONED OVER EACH LOAD UNIT ON A TRAILER. WRITTEN PROOF OF THE MBS OF THE STRAPS SHALL BE PROVIDED BY THE CARRIER TO THE SHIPPING ACTIVITY IF REQUESTED.
5. CARRIERS MUST COMPLY WITH ALL FEDERAL, STATE, AND LOCAL REGULATIONS APPLICABLE TO CARGO RESTRAINT USING WEB STRAPS.
6. WHEN USING STRAPS AND WINCHES FOR CARGO RESTRAINT, THE STRAPS WILL BE TENSIONED UNTIL TIGHT WITHOUT CAUSING DAMAGE TO THE CARGO. ONLY WINCH BARS WILL BE USED FOR OPERATING THE STRAP WINCHES.
7. BEFORE AND DURING INSTALLATION, THE WEB STRAP ASSEMBLIES SHALL BE INSPECTED FOR DEFECTS. STRAPS HAVING ANY OF THE FOLLOWING DEFECTS WILL NOT BE USED FOR THE RESTRAINT OF ANY AMMUNITION LOAD, WITH THE EXCEPTION OF ONE WITH FRAYED ENDS. A STRAP HAVING FRAYED ENDS CAN BE USED IF THE FRAYED END IS TRIMMED AND MELTED WITH HEAT OR FLAME UNTIL ALL STRANDS ARE SEIZED.
  - A. STRAP ASSEMBLY HARDWARE: SHALL BE INSPECTED FOR BENT HOOKS, GOUGES, CORROSION, SIGNS OF REPAIR, BENT RATCHETS OR WINCHES, WEAR, OR ANY OTHER NOTICEABLE DEFECTS.
  - B. STRAP WEBBING: SHALL BE INSPECTED FOR KNOTS, EXCESSIVE ABRASIVE WEAR, TEARS, PUNCTURES, CUTS, ACID OR CAUSTIC BURNS, BROKEN STITCHES, FRAYED ENDS, OIL OR GREASE SPOTS EXCEEDING 6 SQUARE INCHES, BLEACHING OF COLOR, INCREASED STIFFNESS, SPLICES, VISIBLE WEAR INDICATOR THREADS, OR ANY OTHER NOTICEABLE DEFECTS.
8. RATCHET HANDLES MUST BE IN THE LOCKED POSITION AND/OR WINCH LOCKING DEVICES MUST BE FULLY SEATED IN THE TEETH OF THE WINCH.

(CONTINUED AT RIGHT)

BILL OF MATERIAL		
LUMBER	LINEAR FEET	BOARD FEET
1" X 4"	44	15
2" X 4"	31	21
2" X 6"	139	139
NAILS	NO. REQD	POUNDS
6d (2")	48	1/2
10d (3")	232	3-3/4
20d (4")	45	1-3/4
STEEL STRAPPING, 1-1/4" - - 320' REQD - - 45-3/4 LBS		
SEAL FOR 1-1/4" STRAPPING - - 48 REQD - - 2-1/4 LBS		
WEB STRAP ASSEMBLIES - - - - - 8 REQD		
ANTI-CHAFING MATERIAL - - - - AS REQD - - - - NIL		

**SPECIAL NOTES:**

1. A 16-UNIT LOAD IS SHOWN ON A 40'-0" LONG BY 8'-0" WIDE FLATBED TRAILER. THE AVAILABLE NAILING SURFACE OF THE TRAILER BED MUST MEASURE AT LEAST 34'-4" LONG. TRAILERS OF OTHER LENGTHS AND WIDTHS MAY ALSO BE USED.
2. IF THE CAPACITY OF MATERIALS HANDLING EQUIPMENT (MHE) IS ADEQUATE, IT IS RECOMMENDED THAT EACH STACK OF TWO CONTAINERS BE UNITIZED PRIOR TO LOADING ON THE FLATBED TRAILER. IF THIS IS NOT POSSIBLE, THEN THE UNITIZING STRAPS MUST BE POSITIONED AS LOADING PROGRESSES.
3. PLACE ANTI-CHAFING NEUTRAL BARRIER MATERIAL UNDER THE HOLD-DOWN STRAPPING AT ALL POINTS OF CONTACT WITH THE CONTAINER AND SECURE TO PREVENT DISLODGMET DURING AND AFTER STRAP APPLICATION. STRIPS OF ANTI-CHAFING MATERIAL MAY BE TAPED OR STRING TIED TO THE CONTAINER OR STRAPPING, OR IT CAN BE FORMED INTO STRAP ENCIRCLING TUBES BY WINDING THE MATERIAL AROUND THE STRAPPING TO FORM A SELF HOLDING UNIT.
4. THE DEPICTED PROCEDURES ALSO APPLY TO A SHIPMENT OF CBU-89/B BOMBS IN THE CNU-327/E CONTAINER.
5. IF STEEL STRAPPING IS TO BE USED FOR LOAD SECUREMENT, REFER TO THE PROCEDURES ON PAGES 4 AND 5 FOR GUIDANCE.
6. IF CHAINS AND LOAD BINDERS ARE TO BE USED FOR LOAD SECUREMENT, REFER TO THE PROCEDURES ON PAGES 6 AND 7 FOR GUIDANCE.
7. THE LOAD AS SHOWN ON PAGE 8 MAY BE REDUCED BY AN EVEN NUMBER OF UNITS, SUCH AS TWO, FOUR, SIX, OR EIGHT CONTAINERS FROM THE TOP LAYER OF LATERALLY ADJACENT CONTAINERS AS REQUIRED. SEE GENERAL NOTES "E" AND "F" ON PAGE 2.

**(SPECIAL PROVISIONS FOR WEB STRAP TIEDOWN CONTINUED)**

9. IF THE WINCHES BEING USED ARE THE REMOVABLE TYPE HAVING BOLTS FOR ATTACHMENT TO THE TRAILER, CARE MUST BE EXERCISED WHEN ATTACHING THE WINCHES TO THE TRAILER. IF EXCESSIVE FORCE IS EXERTED ON THE BOLT DURING TENSIONING, DEFORMATION OF THE WINCH BRACKET MAY OCCUR, AND SUBSEQUENTLY CAUSE FAILURE OF THE WINCH BRACKET DURING TRANSPORT. WINCHES MUST BE FASTENED TO THE TRAILER WITH A MINIMUM OF TWO BOLTS.
10. DRIVERS MUST BE INSTRUCTED TO PERIODICALLY CHECK THE TIGHTNESS OF THE WEB STRAP ASSEMBLIES AND RE-TIGHTEN, IF NECESSARY.
11. IF PROVIDED ON OR WITH THE WEB STRAP ASSEMBLIES, SCUFF SLEEVES/WEB PROTECTORS WILL BE USED WHEREVER THE STRAP PASSES OVER A SHARP CORNER OR IRREGULAR SURFACE. IF NOT PROVIDED, ANTI-CHAFING MATERIAL OF A SUITABLE THICKNESS WILL BE USED TO INSURE THAT THE STRAP WEBBING IS NOT DAMAGED DURING TRANSPORT OF THE LOAD.
12. THE HARDWARE FITTING OF THE TIEDOWN ASSEMBLIES MUST BE ATTACHED TO THE TRAILER IN SUCH A MANNER THAT THEY WILL REMAIN IN PLACE IF SLACK DEVELOPS IN THE STRAP DURING TRANSPORT.

**LOAD AS SHOWN**

ITEM	QUANTITY	WEIGHT (APPROX)
CONTAINER (w/CBU-87/B)	16	39,776 LBS
DUNNAGE		609 LBS
TOTAL WEIGHT		40,385 LBS (APPROX)

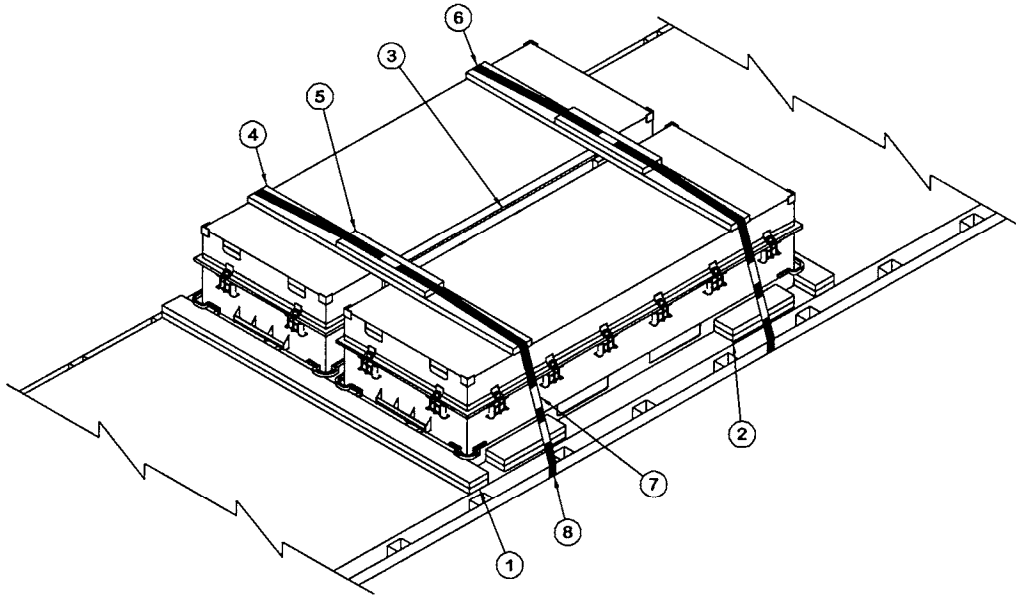

**ISOMETRIC VIEW**

**SPECIAL NOTES:**

1. A 2-CONTAINER LOAD IS SHOWN. HOWEVER, THE DEPICTED PROCEDURES CAN ALSO BE USED FOR THE SHIPMENT OF A 1-CONTAINER LOAD BY MODIFYING THE LOAD AS FOLLOWS:
  - A. OMIT PIECES MARKED ③ AND ⑤.
  - B. USE PIECES MARKED ②, ⑦, AND ⑧ AS SPECIFIED.
  - C. REDUCE THE LENGTH OF THE HEADERS, PIECES MARKED ①, TO 45" AND NAIL WITH 3-10d AND 3-20d NAILS.
  - D. REDUCE THE LENGTH OF THE STRAPPING BOARDS, PIECES MARKED ④, TO 38".
  - E. REDUCE THE LENGTH OF THE HOLD-DOWN STRAPS, PIECES MARKED ⑥, TO 14'-0".
2. REFER TO "SPECIAL PROVISIONS FOR CHAIN TIEDOWN" ON PAGE 7 WHEN CHAINS ARE USED IN LIEU OF STEEL STRAPPING.
3. REFER TO "SPECIAL PROVISIONS FOR WEB STRAP TIEDOWN" ON PAGE 9 WHEN WEB STRAPS ARE USED IN LIEU OF STEEL STRAPPING.

**KEY NUMBERS**

- ① HEADER, 2" X 6" X 7'-6" (DOUBLED) (2 REQD). POSITION THE FIRST PIECE AGAINST THE CONTAINER BASE AND NAIL TO THE TRAILER FLOOR W/5-10d NAILS. NAIL THE SECOND PIECE TO THE FIRST W/5-20d NAILS. SEE GENERAL NOTE "J" ON PAGE 2.
- ② SIDE BLOCKING, 2" X 6" X 18" (DOUBLED) (4 REQD). POSITION THE FIRST PIECE AGAINST THE CONTAINER SIDE AS SHOWN AND NAIL W/5-10d NAILS. NAIL THE SECOND PIECE TO THE FIRST IN A LIKE MANNER.
- ③ ANTI-CHAFING ASSEMBLY (1 REQD). SEE THE "ANTI-CHAFING ASSEMBLY" DETAIL ON PAGE 5.
- ④ STRAPPING BOARD, 2" X 6" X 6'-6" (2 REQD). POSITION ON TOP OF THE CONTAINERS AS SHOWN ABOVE.
- ⑤ PURCHASE BOARD, 2" X 6" X 26" (2 REQD). CENTER ON THE STRAPPING BOARD, PIECE MARKED ⑦, AND NAIL W/4-10d NAILS.
- ⑥ HOLD-DOWN STRAP, 2" X .050" OR .044" X 15'-0" LONG STEEL STRAPPING (2 REQD). POSITION OVER THE TOP OF THE LOAD AS SHOWN ABOVE AND FASTEN TO THE TRAILER SIDE RAILS AS PER HOLD-DOWN STRAP ANCHORING DETAILS ON PAGE 11. STAPLE TO THE STRAPPING BOARD W/1 STAPLE AT EACH END. SEE GENERAL NOTE "H" ON PAGE 2.
- ⑦ SEAL FOR 2" STEEL STRAPPING (10 REQD, 5 PER STRAP). FASTEN PIECE MARKED ⑥ WITH ONE SEAL, CRIMPED WITH TWO PAIR OF NOTCHES AT EACH JOINT, EXCEPT THOSE USED TO SECURE THE PADS, PIECE MARKED ⑧ WHICH REQUIRES ONE SEAL WITH ONE PAIR OF NOTCHES. SEE THE "HOLD-DOWN STRAP ANCHORING" DETAILS ON PAGE 11 AND GENERAL NOTE "K" ON PAGE 2.
- ⑧ PAD, 2" X .050" OR .044" X 18" LONG STEEL STRAPPING (4 REQD). POSITION UNDER THE ANCHORING FACILITY AND SEAL TO THE HOLD-DOWN STRAP, PIECE MARKED ⑥. ALT: STAKE POCKET PROTECTOR (8 REQD). USE TWO UNDER EACH ANCHORING FACILITY WITH ONE HOLD-DOWN STRAP. SEE THE "HOLD-DOWN STRAP ANCHORING" DETAILS ON PAGE 11.

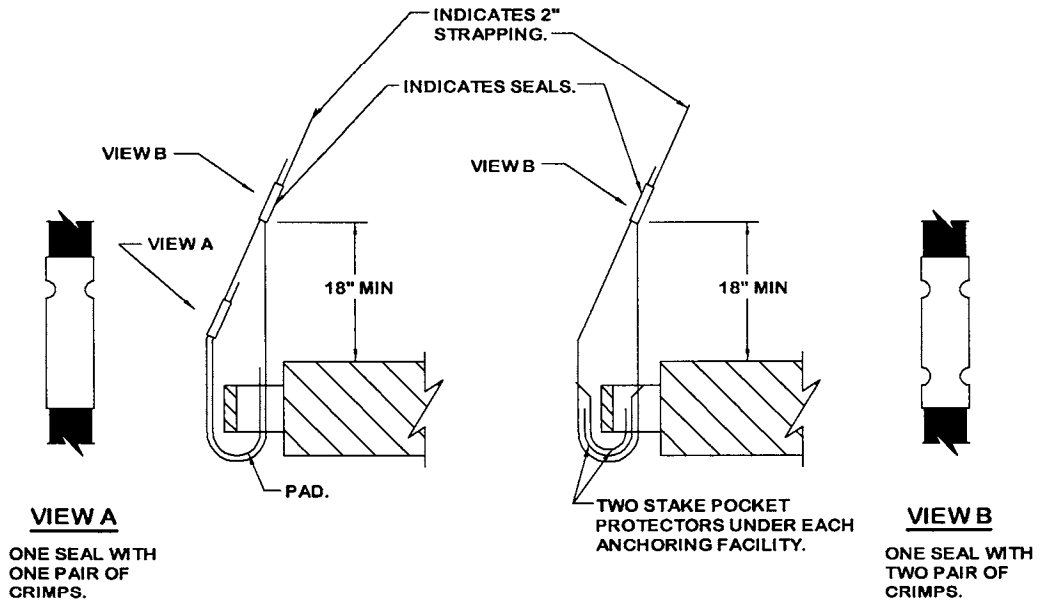

**DETAIL A**  
 METHOD OF INSTALLING  
 2" STRAPPING AND PAD  
 AT ANCHORING FACILITY.

**DETAIL B**  
 METHOD OF INSTALLING  
 2" STRAPPING AND STAKE  
 POCKET PROTECTORS  
 (ALT PAD).

**HOLD-DOWN STRAP ANCHORING DETAILS**

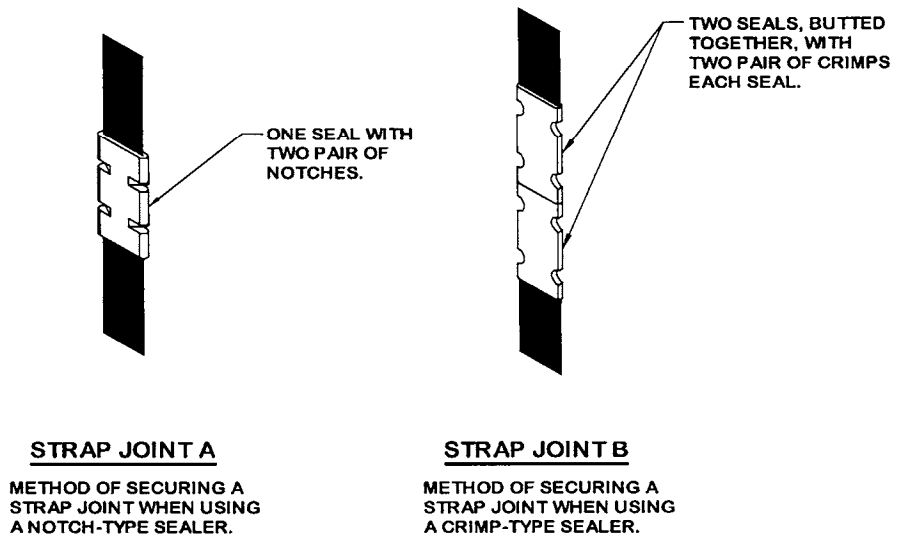

**STRAP JOINT A**  
 METHOD OF SECURING A  
 STRAP JOINT WHEN USING  
 A NOTCH-TYPE SEALER.

**STRAP JOINT B**  
 METHOD OF SECURING A  
 STRAP JOINT WHEN USING  
 A CRIMP-TYPE SEALER.

**END-OVER-END LAP JOINT DETAILS**

**PROVISIONS FOR THE USE OF FIREHOSE IN LIEU  
OF CHAIN BOARDS OR STRAPPING BOARDS**

FIRE HOSE THAT IS NO LONGER SUITABLE FOR USE IN FIRE FIGHTING APPLICATIONS CAN BE SUBSTITUTED FOR THE DOUBLED 2" BY 6" WOODEN CHAIN BOARDS OR SINGLE 2" BY 6" STRAPPING BOARDS, AS SPECIFIED HEREIN, PROVIDED THE FOLLOWING CONDITIONS ARE MET.

**1. SUBSTITUTION AND APPLICATION GUIDANCE**

- A. FIRE HOSE MAY BE USED WHEREVER A CHAIN OR STRAPPING BOARD CONTACTS A RIGID SURFACE OF THE LOAD PROVIDED GOUGING, SCRATCHING, CRACKING, BENDING, CRUSHING, OR OTHER VISIBLE DAMAGE DOES NOT OCCUR TO THE LOAD.
- B. ONE OR MORE SEGMENTS OF FIRE HOSE MAY BE USED TO REPLACE EACH CHAIN OR STRAPPING BOARD PROVIDING LOAD PROTECTION DURING TENSIONING OF TIEDOWNS AND LOAD SHIPMENT; I.E., A CHAIN BOARD NEED NOT BE REPLACED BY A SINGLE SEGMENT OF HOSE, MULTIPLE SEGMENTS MAY BE USED INSTEAD, AS LONG AS THEY ARE SECURELY FASTENED TO THE TIEDOWN. REGARDLESS OF THE NUMBER OF SEGMENTS USED, THE HOSE LENGTH WILL BE SUCH THAT IT EXTENDS AT LEAST 6" BEYOND THE EDGE OF THE LOAD.
- C. FIRE HOSE CANNOT BE USED IN PLACE OF A PURCHASE BOARD ON A LOAD CONSISTING OF MORE THAN TWO PALLETS OR CONTAINERS ACROSS THE WIDTH OF THE TRAILER. THE FIRE HOSE CAN BE APPLIED TO THE OUTER STACKS, HOWEVER, A PURCHASE BOARD ASSEMBLY WILL STILL BE REQUIRED TO PROVIDE VERTICAL HOLD-DOWN ON THE CENTER STACK(S).

**2. ACCEPTABLE FIRE HOSE**

- A. FIRE HOSE TO BE USED WILL BE A RUBBER LINED SINGLE OR DOUBLE JACKETED TYPE; I.E., IT MUST HAVE A RUBBER LINING INSIDE A SINGLE OR DOUBLED FABRIC (COTTON, LINEN, ETC.) JACKET.
- B. THE COLLAPSED WIDTH OF THE HOSE MUST BE A MINIMUM OF 2-1/2".
- C. THE HOSE SEGMENTS USED MUST NOT CONTAIN DEFECTS THAT WILL ALLOW DIRECT CONTACT OF THE CHAIN OR LOAD BINDER WITH THE LOAD. THE HOSE THICKNESS MUST ALSO BE OF SUCH A THICKNESS THAT DENTING OR DAMAGE TO THE LOAD DOES NOT OCCUR DURING CHAIN OR STRAP TENSIONING.

**3. SECUREMENT TO CHAINS OR STRAPS**

- A. THE SEGMENTS OF HOSE USED UNDER EACH CHAIN OR STRAP WILL BE SECURED TO THE CHAIN OR STRAP WITH ONE FASTENER EVERY 12", WITH A MINIMUM OF TWO FASTENERS REQUIRED PER HOSE SEGMENT.
- B. FASTENERS CAN CONSIST OF PLASTIC ELECTRICAL TIES, .0800" DIAMETER WIRE, OR TAPE. REGARDLESS OF THE TYPE OF FASTENING USED, IT MUST PROVIDE A POSITIVE MEANS OF SECUREMENT OF THE HOSE TO THE CHAIN OR STRAP AND MUST NOT DAMAGE THE SURFACE OF THE CONTAINER, PALLET, OR ITEM IT CONTACTS.