

APPROVED BY U.S. COAST GUARD <i>R.W. Tanner</i>	APPROVED BY HAZARDOUS MATERIALS SYSTEMS (BOE) ASSOCIATION OF AMERICAN RAILROADS <i>J.H. Glesner</i>
DATE <u>7/2/88</u>	DATE <u>6/18/88</u>

LOADING AND BRACING¹ ON COMMERCIAL FLATRACK CONTAINERS OF MK-84 (2,000 POUND) BOMBS ON METAL PALLETES WITH ADAPTORS

INDEX

ITEM	PAGE(S)
GENERAL NOTES AND MATERIAL SPECIFICATIONS -----	2
PALLET UNIT DETAIL -----	3
TYPICAL FULL LOAD PROCEDURES -----	4,5
GENERAL DETAILS -----	6-8

- ① LOADING AND BRACING SPECIFICATIONS SET FORTH WITHIN THIS DRAWING ARE APPLICABLE TO LOADS THAT ARE TO BE SHIPPED BY TRAILER/CONTAINER-ON-FLAT-CAR (T/COFC) RAIL CARRIER SERVICE. THESE SPECIFICATIONS MAY ALSO BE USED FOR LOADS THAT ARE TO BE MOVED BY MOTOR OR WATER CARRIERS. SEE GENERAL NOTE "L" ON PAGE 2.

REVISIONS				DRAFTSMAN <i>HW</i>	PROJ ENG <i>JM</i>
				CHECKER <i>GRS</i>	LOG ENGRG OFFICE <i>W.F. Ernst</i>
				APPROVED, U.S. ARMY ARMAMENT, MUNITIONS AND CHEMICAL COMMAND <i>S.D. Boyd TMS</i>	
				APPROVED BY ORDER OF COMMANDING GENERAL, U.S. ARMY MATERIEL COMMAND (AMC) <i>William F. Ernst</i> U.S. ARMY DEFENSE AMMUNITION CENTER AND SCHOOL	
				U.S. ARMY AMC DRAWING	
				AUGUST 1988	
				CLASS	DIVISION
				19	48
				DRAWING	FILE
				7074	15PB2

DO NOT SCALE

GENERAL NOTES

- A. THIS DOCUMENT HAS BEEN PREPARED AND ISSUED IN ACCORDANCE WITH AR 740-1, AND AUGMENTS TM 743-200-1 (CHAPTER 5).
- B. ALL LOADS SHIPPED BY THE PROCEDURES DEPICTED IN THIS DRAWING MUST BE IN ACCORDANCE WITH THE REQUIREMENTS SET FORTH IN TITLE 49, THE UNITED STATES CODE OF FEDERAL REGULATIONS; AR 55-355/AFM 75-2; DOD 4500-32-R; DOD 5100.76-M; DOD 6055.9-STD; AS WELL AS ANY AND ALL OTHER APPLICABLE SERVICE REGULATIONS.
- C. THE SPECIFIED OUTLOADING PROCEDURES ARE APPLICABLE TO THE MK-84 (2000 POUND) BOMB ON A METAL PALLET. SUBSEQUENT REFERENCE TO PALLET UNIT HEREIN MEANS THE METAL PALLET WITH MK-84 BOMBS INSTALLED. SEE PAGE 3 FOR THE DETAIL OF THE PALLET UNIT. **CAUTION:** REGARDLESS OF THE QUANTITY OF PALLETS TO BE SHIPPED, THE "MAXIMUM GROSS WEIGHT" OF THE FLAT-RACK INCLUDING LADING AND DUNNAGE MUST NOT BE EXCEEDED.
- D. A STAGGERED NAILING PATTERN WILL BE USED WHEREVER POSSIBLE, WHEN NAILS ARE DRIVEN INTO THE JOINTS OF DUNNAGE ASSEMBLIES OR WHEN LAMINATING DUNNAGE. ADDITIONALLY, THE NAILING PATTERN FOR AN UPPER PIECE OF LAMINATED DUNNAGE WILL BE ADJUSTED AS REQUIRED SO THAT A NAIL FOR THAT PIECE WILL NOT BE DRIVEN THROUGH, ONTO OR RIGHT BESIDE A NAIL IN A LOWER PIECE.
- E. THE LOAD AS SHOWN IS BASED ON A 20' - 0" LONG BY 8' - 0" WIDE COMMERCIAL FLATRACK CONTAINER WITH FULL HEIGHT ENDWALLS, AND INSIDE DIMENSIONS OF 18' - 8" LONG BY 7' - 10" WIDE. THE LOAD AS SHOWN CAN BE SHIPPED BY ANY FORM OF SURFACE TRANSPORTATION. **NOTICE:** OTHER FLATRACK CONTAINERS OF THE SAME DESIGN CONFIGURATION CAN ALSO BE USED.
- F. DUNNAGE LUMBER SPECIFIED IS OF A NOMINAL SIZE. FOR EXAMPLE, 1" X 6" MATERIAL IS ACTUALLY 3/4" THICK BY 5-1/2" WIDE AND 2" X 6" MATERIAL IS ACTUALLY 1-1/2" THICK BY 5-1/2" WIDE.
- G. WHEN LOADING THE PALLET UNITS, THEY ARE TO BE POSITIONED SO AS TO ACHIEVE A TIGHT LOAD BETWEEN THE LOAD BEARING GATES AND THE SEPARATOR GATE. ALTHOUGH A TOTAL OF ONE HALF INCH (1/2") OF UNBLOCKED SPACE ACROSS THE WIDTH OR ALONG THE LENGTH OF THE LOAD IS PERMITTED, LATERAL AND LONGITUDINAL VOIDS ARE TO BE HELD TO A MINIMUM. EXCESSIVE SLACK CAN BE ELIMINATED FROM A LOAD BY LAMINATING ADDITIONAL PIECES OF APPROPRIATE THICKNESS DUNNAGE TO THE LOAD BEARING GATE (S) AND/OR SEPARATOR GATE FOR LONGITUDINAL SLACK AND FILL PIECES TO THE SIDE BLOCKING FOR LATERAL SLACK. NAIL EACH ADDITIONAL PIECE OF DUNNAGE W/1 APPROPRIATELY SIZED NAIL EVERY EIGHT INCHES (8").
- H. PORTIONS OF THE FLATRACK ENDWALLS DEPICTED WITHIN THIS DRAWING HAVE NOT BEEN SHOWN IN THE LOAD VIEWS FOR CLARITY PURPOSES.
- J. WHEN INSTALLING THE LOAD BEARING GATES, THE GATE ASSEMBLY MUST BE POSITIONED SO AS TO BE SUPPORTED AND IN LINE WITH THE STRONG POINTS OF THE FLATRACK ENDWALLS. **NOTE:** SOME FLATRACK ENDWALLS WILL REQUIRE FILL PIECES TO BE INSTALLED ON THE LOAD BEARING GATE TO PROVIDE A UNIFORM LOAD BEARING SURFACE. NAIL THESE FILL PIECES TO THE LOAD BEARING GATE W/1 APPROPRIATELY SIZED NAIL EVERY EIGHT INCHES (8").
- K. WHEN STEEL STRAPPING IS SEALED AT AN END-OVER-END LAP JOINT, A MINIMUM OF ONE (1) SEAL WITH TWO (2) PAIR OF NOTCHES WILL BE USED TO SEAL THE JOINT WHEN A NOTCH-TYPE SEALER IS BEING USED. A MINIMUM OF TWO (2) SEALS, BUTTED TOGETHER, WITH TWO (2) PAIR OF CRIMPS PER SEAL WILL BE USED TO SEAL THE JOINT WHEN A CRIMP-TYPE SEALER IS BEING USED. REFER TO THE "STRAP JOINT A" AND "STRAP JOINT B" DETAILS ON PAGE 8 FOR GUIDANCE.
- L. REQUIREMENTS CITED WITHIN THE BUREAU OF EXPLOSIVES PAMPHLET 6C APPLY WHEN THE SHIPMENT MOVES BY TRAILER/CONTAINER-ON-FLAT-CAR (T/COFC). SPECIAL T/COFC NOTES FOLLOW.
1. A LOADED CONTAINER MUST BE ON A CHASSIS EQUIPPED WITH TWO BOGIE ASSEMBLIES WHEN BEING MOVED IN TOFC SERVICE.
 2. THE LOAD LIMIT OF A T/COFC RAILCAR MUST NOT BE EXCEEDED, NOR WILL A CAR BE LOADED SO THAT THE TRUCK UNDER ONE END OF THE CAR CARRIES MORE THAN ONE-HALF OF THE LOAD LIMIT FOR THAT CAR.

(CONTINUED AT RIGHT)

MATERIAL SPECIFICATIONS

<u>LUMBER</u> -----:	SEE TM 743-200-1, DUNNAGE LUMBER, FED SPEC MM-L-751.
<u>NAILS</u> -----:	COMMON; FED SPEC FF-N-105.
<u>STRAPPING, STEEL</u> -----:	CLASS 1, TYPE I OR IV, HEAVY DUTY, FINISH A, B (GRADE 2), OR C; FED SPEC QQ-S-781.
<u>STRAP SEAL</u> -----:	TYPE D, STYLE I, II, OR III, CLASS H, FINISH A, B (GRADE 2), OR C; FED SPEC QQ-S-781.
<u>STRAP STAPLE</u> -----:	COMMERCIAL GRADE.

(GENERAL NOTES CONTINUED)

- M. THE 2" STRAPPING USED FOR LOAD SECUREMENT, I. E., HOLD-DOWN STRAPS, WILL ONLY BE FASTENED TO THE FLATRACK CONTAINER BY UTILIZING TIEDOWN PROVISIONS LOCATED ON THE TOP OR ALONG THE SIDE OF THE FLATRACK BOTTOM SIDE RAILS. **CAUTION:** THE LOAD SECUREMENT STRAPS WILL NOT BE POSITIONED AROUND THE UNDERSIDE OR THROUGH THE FORKLIFT POCKETS OF THE FLATRACK CONTAINER. ADDITIONALLY, THE FLATRACK TIEDOWN PROVISIONS MUST BE AT LEAST AS STRONG AS THE 2" LOAD SECUREMENT STRAPPING BEING USED; BE OF A SUFFICIENT WIDTH TO RECEIVE THE 2" STRAPPING, AND BE OF A DESIGN WHICH WILL PROVIDE A BEARING SURFACE ACROSS THE FULL WIDTH OF THE 2" STRAPPING SO THAT THE STRAPPING WILL NOT BE DEFORMED, ESPECIALLY AT ITS EDGE, WHEN PROPERLY TENSIONED.
- N. REFER TO ASSOCIATION OF AMERICAN RAILROADS MANUAL, "GENERAL RULES GOVERNING THE LOADING OF COMMODITIES ON OPEN TOP CARS", FOR APPLICABLE LOADING RULES AS FOLLOWS: PREFACE, 1A, 2, 5, 10, AND 15. **NOTE** THAT ALL STRAPPING USED FOR LOAD SECUREMENT, I. E., HOLD-DOWN STRAPS, MUST BE MARKED AS SPECIFIED IN LOADING RULE 15.
- O. CONVERSION TO METRIC EQUIVALENTS:
- P. DIMENSIONS WITHIN THIS DOCUMENT ARE EXPRESSED IN INCHES AND WEIGHTS ARE EXPRESSED IN POUNDS. WHEN NECESSARY, THE METRIC EQUIVALENTS MAY BE COMPUTED ON THE BASIS OF ONE INCH EQUALS 25.4MM AND ONE POUND EQUALS 0.454KG.
- Q. DURING INTRASTATE AND/OR INTERSTATE MOVES BY MOTOR CARRIER, A PROPER CHASSIS OR MODIFIED FLAT BED TRAILER MUST BE USED TO PRECLUDE VIOLATION OF ONE OR MORE "WEIGHT LAWS" APPLICABLE TO THE STATE OR STATES INVOLVED.

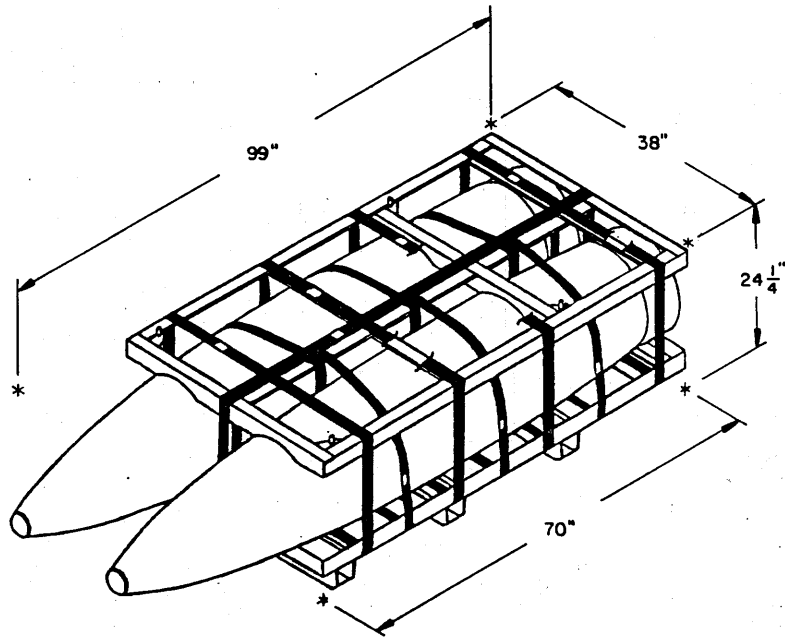

PALLET UNIT

BOMB	-----	2 EACH @ 1,930 LBS (APPROX)
CUBE	-----	55.5 CUBIC FT (APPROX)
GROSS WEIGHT	-----	4,133 LBS (APPROX)

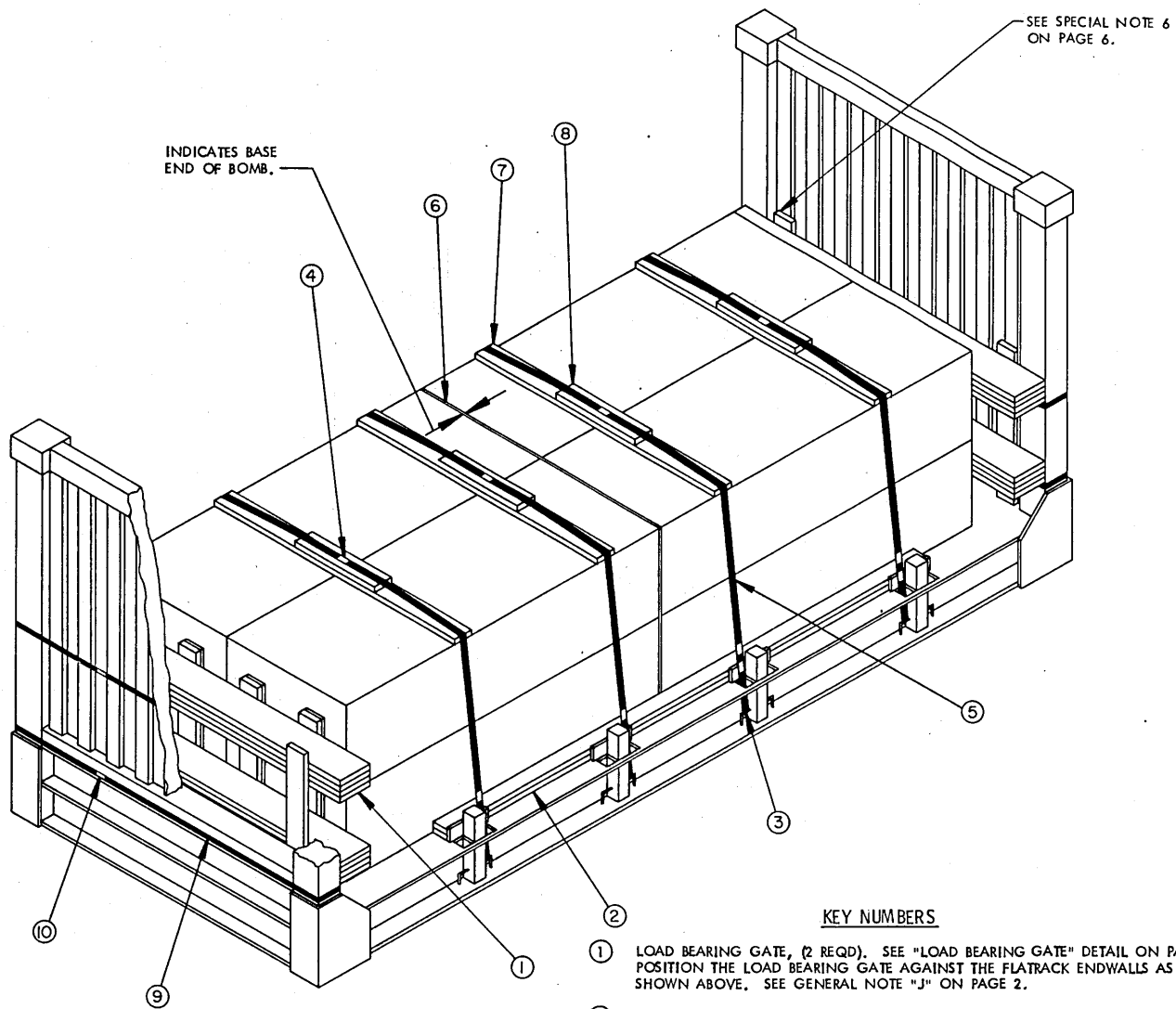

KEY NUMBERS

- ① LOAD BEARING GATE, (2 REQD). SEE "LOAD BEARING GATE" DETAIL ON PAGE 6. POSITION THE LOAD BEARING GATE AGAINST THE FLATRACK ENDWALLS AS SHOWN ABOVE. SEE GENERAL NOTE "J" ON PAGE 2.
- ② SIDE BLOCKING, 2" X 6" BY A LENGTH TO SUIT (REF: 12' - 0") (DOUBLED) (2 REQD). SEE "SIDE BLOCKING" DETAIL ON PAGE 7. SEE SPECIAL NOTE 2 ON PAGE 5 AND GENERAL NOTES "D" AND "G" ON PAGE 2.
- ③ PAD, STRAPPING, 2" X .050" X 18" (8 REQD). POSITION BETWEEN PIECE MARKED ⑤ AND THE FLATRACK TIEDOWN POINT. SEE "TIEDOWN DETAIL" ON PAGE 8.
- ④ SEAL FOR 2" STRAPPING, (20 REQD, 5 PER STRAP). FASTEN PIECE MARKED ⑤ WITH ONE (1) SEAL CRIMPED WITH TWO (2) PAIR OF NOTCHES. FASTEN PIECE MARKED ③ WITH ONE (1) SEAL CRIMPED WITH ONE (1) PAIR OF NOTCHES. SEE "TIEDOWN DETAIL" ON PAGE 8 AND GENERAL NOTE "K" ON PAGE 2.
- ⑤ HOLD-DOWN STRAP, 2" X .050" BY A LENGTH TO SUIT (REF: 18' - 0") (4 REQD). FORM EACH HOLD-DOWN STRAP FROM TWO 9' - 0" PIECES AND POSITION OVER THE TOP OF THE LOAD AS SHOWN ABOVE. SEE GENERAL NOTE "M" ON PAGE 2.
- ⑥ SEPARATOR GATE (1 REQD). SEE "SEPARATOR GATE" DETAIL ON PAGE 6. POSITION BETWEEN THE PALLET UNITS AS SHOWN ABOVE.
- ⑦ STRAPPING BOARD, 2" X 6" X 6' - 3" (4 REQD). POSITION ON TOP AND VERTICALLY IN LINE WITH THE FLATRACK TIEDOWN POINTS. SEE SPECIAL NOTE 5 ON PAGE 5 AND GENERAL NOTE "M" ON PAGE 2.
- ⑧ PURCHASE BOARD, 2" X 6" X 25" (4 REQD). CENTER ON THE STRAPPING BOARD, PIECE MARKED ⑦, AND NAIL W/3-10d NAILS.
- ⑨ GATE STRAP, 1-1/4" X .031" OR .035" BY A LENGTH TO SUIT (REF: 20' - 0") (4 REQD). POSITION AROUND THE ENTIRE LOAD BEARING GATE, PIECE MARKED ①, AS WELL AS THE FLATRACK ENDWALL AS SHOWN ABOVE. SEE SPECIAL NOTE 6 ON PAGE 5.
- ⑩ SEAL FOR 1-1/4" STRAPPING (4 REQD). FASTEN PIECE MARKED ⑨ WITH ONE (1) SEAL CRIMPED WITH TWO (2) PAIR OF NOTCHES. SEE GENERAL NOTE "K" ON PAGE 2.

SPECIAL NOTES:

1. THE LOAD AS SHOWN ON PAGE 4 MAY BE REDUCED BY ONE-HALF FOR A SHIPMENT OF 4 PALLET UNITS ON THE FIRST LAYER, FOR A LOAD WEIGHT OF 16,532 POUNDS. NOTICE: NO OTHER LESS-THAN-FULL LOADS MAY BE SHIPPED BY THE PROCEDURES DEPICTED WITHIN THIS DRAWING.
2. IF THE FLATRACK BEING USED TO SHIP THE LOAD IS EQUIPPED WITH A NAILABLE WOODEN FLOOR THAT EXTENDS AT LEAST FIVE AND ONE-HALF INCHES (5-1/2") PAST THE SIDES OF EACH PALLET UNIT, DOUBLED 2" X 6" NAILED TO THE FLOOR CAN BE USED IN LIEU OF THE 4" X 4" SIDE STAKES SHOWN IN THE LOAD ON PAGE 4 AND IN THE SIDE BLOCKING DETAIL ON PAGE 7. NAIL THE FIRST 2" X 6" TO THE FLOOR W/1-12d NAIL EVERY FOUR INCHES (4"). NAIL THE SECOND PIECE TO THE FIRST IN A LIKE MANNER. SEE GENERAL NOTE "D" ON PAGE 2.
3. WHEN LOADING THE FLATRACK WITH MK-84 BOMBS, THE PALLET UNITS MUST BE POSITIONED WITH THE BASE ENDS OF THE BOMBS AT THE CENTER OF THE LOAD.
4. PRIOR TO LOADING THE MK-84 BOMBS ON THE FLATRACK FOR SHIPMENT, TWO (2) BUNDLING STRAPS MUST BE INSTALLED UNITIZING THE PALLET UNITS. SEE THE "PALLET UNIT STACK STRAPPING DETAIL" AND NOTE ON PAGE 7.
5. THE STRAPPING BOARDS MUST BE POSITIONED ON THE UPPER FRAME ASSEMBLY ON THE METAL PALLET, AND VERTICALLY IN LINE WITH THE FLATRACK TIEDOWN POINTS WHEN VIEWED FROM THE SIDE.
6. THE GATE STRAP, PIECE MARKED ②, MUST BE POSITIONED SO AS TO ENCOMPASS THE ENTIRE LOAD BEARING GATE, PIECE MARKED ①, AND THE FLATRACK ENDWALLS. THE STRAPS SHOULD BE POSITIONED AS CLOSE TO THE UPPER AND LOWER BEAM ASSEMBLIES AS POSSIBLE, BUT ARE NOT TO BE LOCATED SO AS TO BE CAUGHT IN CONTACT BETWEEN THE NOSE END OF A BOMB AND A VERTICAL PIECE OF THE LOAD BEARING GATE.

BILL OF MATERIAL

LUMBER	LINEAR FEET	BOARD FEET
1" X 4"	4	2
1" X 6"	28	14
2" X 4"	13	9
2" X 6"	124	124
2" X 10"	128	205
4" X 4"	12	16
NAILS	NO. REQD	POUNDS
10d (3")	362	5-3/4
12d (3-1/4")	16	1/4
PLYWOOD, 1/2"-----	26 SQ FT REQD	35 LBS
STEEL STRAPPING, 1-1/4" X .035" OR .031"-----	84' REQD	11-1/2 LBS
SEAL FOR 1-1/4" STRAPPING -----	4 REQD	1/2 LBS
STEEL STRAPPING, 2" X .050" -----	84' REQD	28 LBS
SEAL FOR 2" STRAPPING -----	20 REQD	4 LBS

LOAD AS SHOWN

ITEM	QUANTITY	WEIGHT (APPROX)
PALLET UNIT -----	8	33,064 LBS
DUNNAGE -----		825 LBS
CONTAINER -----		5,732 LBS
TOTAL WEIGHT -----		39,621 LBS

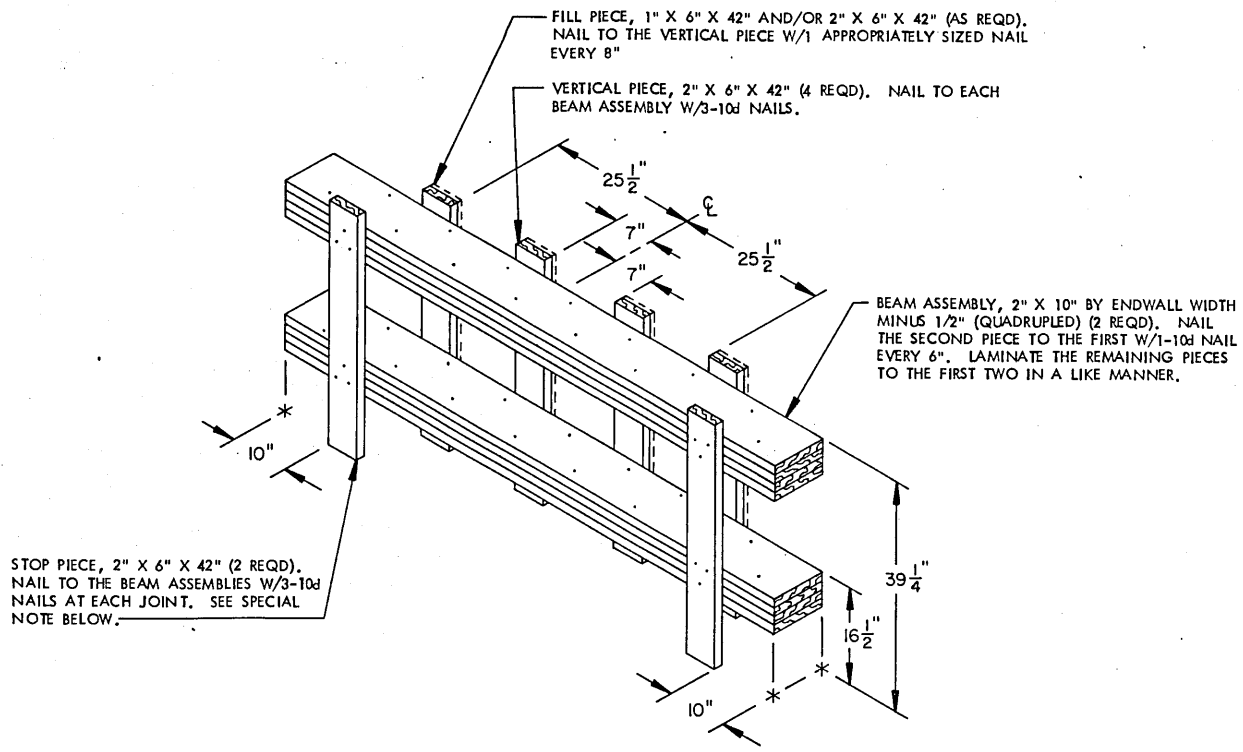

LOAD BEARING GATE

SPECIAL NOTE:

STOP PIECES ON THE "LOAD BEARING GATE" DEPICTED ABOVE MUST BE LOCATED INTERIOR TO THE FLATRACK VERTICAL END WALL POSTS, SO AS TO PROVIDE FOR A TIGHT FIT. THE 10" LOCATION DIMENSION MAY BE ADJUSTED AS REQUIRED, DUE TO FLATRACK END WALL VARIANCE.

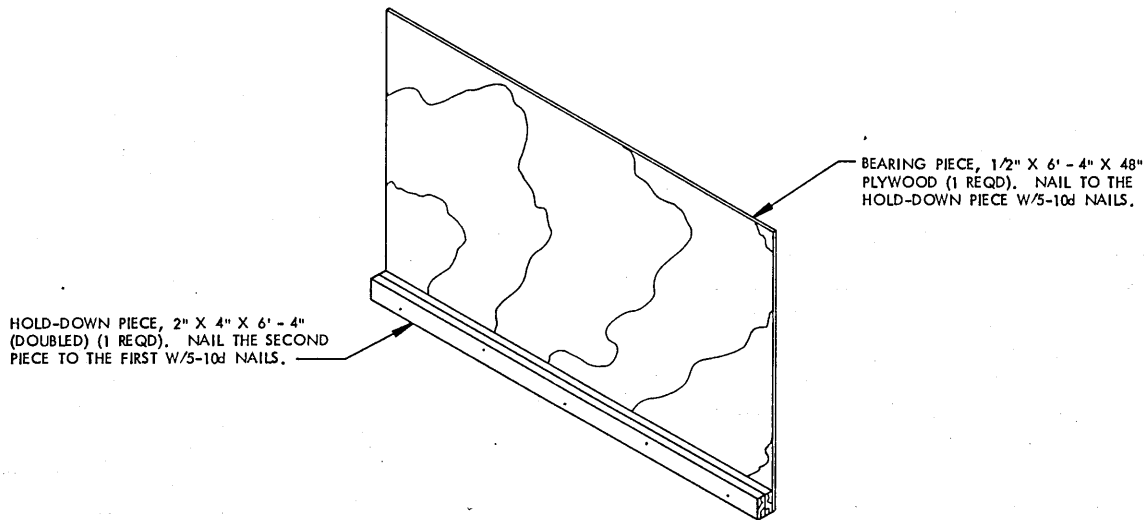

SEPARATOR GATE

(*)
SEAL FOR 1-1/4" STRAPPING (2 REQD). FASTEN THE STRAP WITH ONE (1) SEAL CRIMPED WITH TWO (2) PAIR OF NOTCHES.

STRAP, 1-1/4" X .035" OR .031" BY A LENGTH-TO-SUIT (REF: 20' - 0") (2 REQD). INSTALL IN A "FIGURE-8" CONFIGURATION IN THE LATERAL DIRECTION.

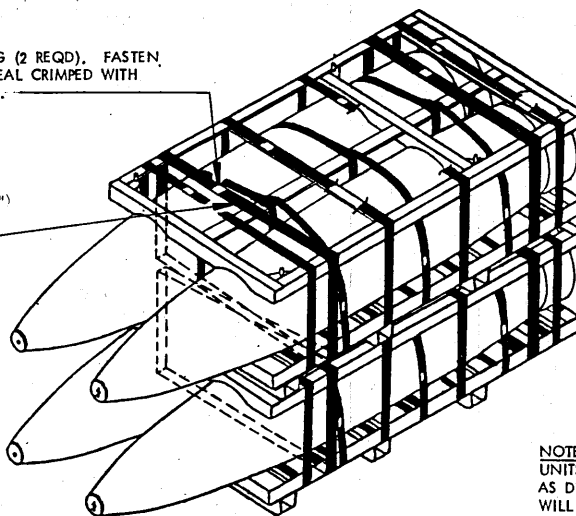

PALLET UNIT STACK STRAPPING DETAIL

NOTE: PRIOR TO SHIPMENT OF THE MK-84 PALLET UNITS, TWO (2) BUNDLING STRAPS MUST BE INSTALLED AS DETAILED AND SPECIFIED ABOVE. INSTALLATION WILL BE ACCOMPLISHED BY TWO (2) 1-1/4" X .031" OR .035" STEEL STRAPS (INSTALLED IN A "FIGURE 8" CONFIGURATION IN THE LATERAL DIRECTION) WITH EACH STRAP BEING FASTENED WITH ONE (1) 1-1/4" SEAL CRIMPED WITH TWO (2) PAIR OF NOTCHES. SEE GENERAL NOTE "K" ON PAGE 2.

FILL PIECE, 1" X 4" X 12" AND/OR 2" X 4" X 12" (AS REQD). POSITION BETWEEN THE SIDE STAKE AND THE SIDE BLOCKING AND NAIL TO THE SIDE BLOCKING W/3-10d NAILS. SEE GENERAL NOTE "G" ON PAGE 2

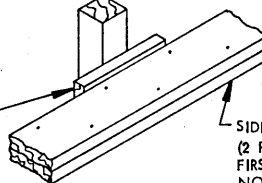

SIDE STAKE, 4" X 4" (CUT FOR A TIGHT FIT) X 18" (8 REQD). TOENAIL TO THE FILL PIECE W/2-12d NAILS AT EACH JOINT.

SIDE BLOCKING, 2" X 6" X 12' - 0" (DOUBLED) (2 REQD). NAIL THE SECOND PIECE TO THE FIRST W/1-10d NAIL EVERY 8". SEE GENERAL NOTE "D" ON PAGE 2.

SIDE BLOCKING DETAIL

(SEE THE "INSTALLATION PROCEDURES" BELOW.)

INSTALLATION PROCEDURES:

- STEP 1: POSITION THE ASSEMBLED SIDE BLOCKING AGAINST THE PALLET UNITS.
- STEP 2: INSTALL THE SIDE STAKES IN THE FLATRACK CONTAINER STAKE POCKETS. NOTE THAT THE SIDE STAKES MUST BE CUT TO FIT TIGHTLY INTO THE STAKE POCKETS.
- STEP 3: POSITION FILL PIECE(S) BETWEEN THE SIDE BLOCKING AND SIDE STAKE SO AS TO ALLOW NO MORE THAN ONE-HALF INCH (1/2") OF LATERAL VOID BETWEEN THE PALLET UNITS AND SIDE BLOCKING.
- STEP 4: REPEAT STEPS 1, 2, AND 3 ON THE OPPOSITE SIDE OF THE FLATRACK.

DETAILS

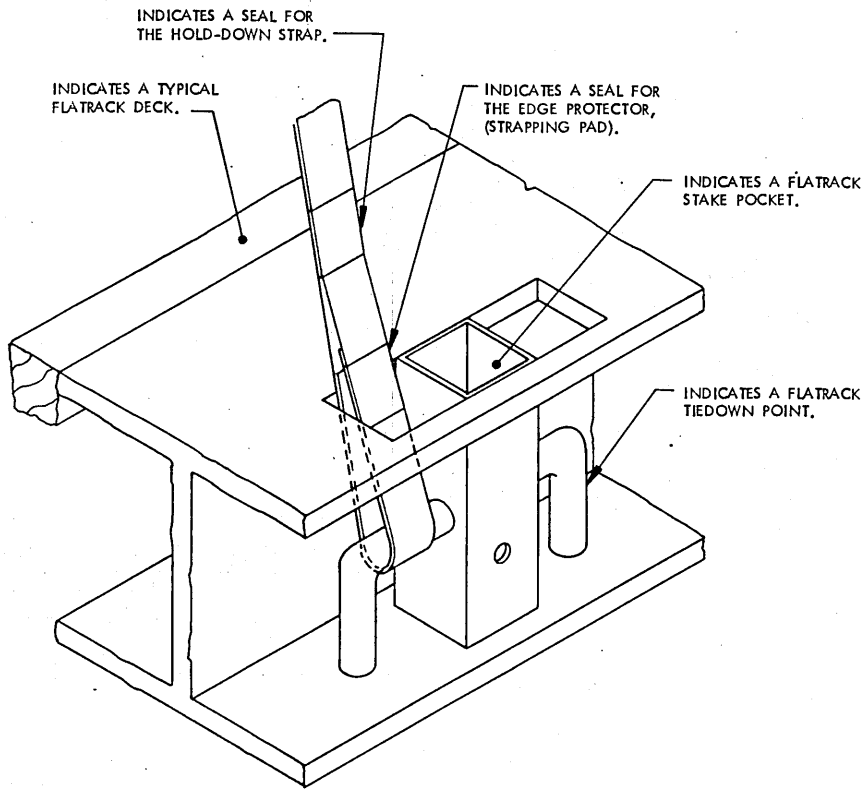

ISOMETRIC VIEW

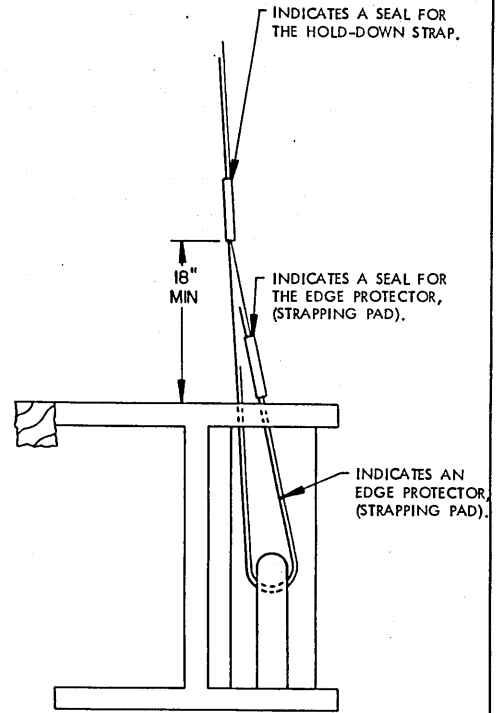

SIDE VIEW

TIEDOWN DETAIL

NOTE: THIS PROCEDURE IS USED FOR TIE-DOWN OF THE LOAD USING FLATRACK SIDE RAIL TIEDOWN POINTS. SEE GENERAL NOTE "M" ON PAGE 2

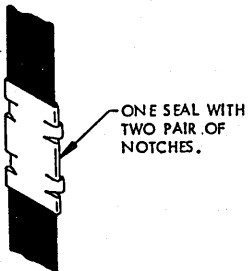

ONE SEAL WITH TWO PAIR OF NOTCHES.

STRAP JOINT A

METHOD OF SECURING A STRAP JOINT WHEN USING A NOTCH-TYPE SEALER.

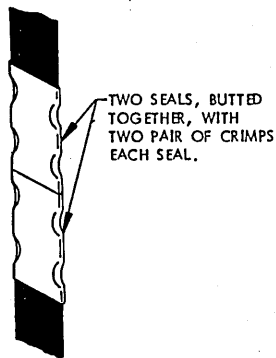

TWO SEALS, BUTTED TOGETHER, WITH TWO PAIR OF CRIMPS EACH SEAL.

STRAP JOINT B

METHOD OF SECURING A STRAP JOINT WHEN USING A CRIMP-TYPE SEALER.

STRAP/SEAL DETAIL

DETAILS