

THAAD

STORAGE IN APPROVED MAGAZINES OF TERMINAL HIGH ALTITUDE AREA DEFENSE (THAAD) MISSILE PACKED IN SINGLE MISSILE ROUND TRANSPORT CONTAINER (SMRTC)

| <u>ITEM</u> | <u>INDEX</u> | <u>PAGE(S)</u> |
|---------------------------------------------------|--------------|----------------|
| GENERAL NOTES AND MATERIAL SPECIFICATIONS | - - - - - | 2 |
| SMRTC CONTAINER DETAIL | - - - - - | 3 |
| 80'-0" L X 25'-0" W X 11'-0" H ARCH TYPE MAGAZINE | - - - - - | 4-5 |
| 81'-0" L X 26'-6" W X 12'-9" H IGLOO MAGAZINE | - - - - - | 6-7 |
| 44'-7" DIA CORBETTA MAGAZINE | - - - - - | 8-9 |
| 52'-0" DIA CORBETTA MAGAZINE | - - - - - | 10-11 |
| OVAL ARCH MAGAZINE | - - - - - | 12-13 |
| STEEL ARCH MAGAZINE | - - - - - | 14-15 |
| TYPE II BUNKER | - - - - - | 16-17 |
| TYPE III BUNKER | - - - - - | 18-19 |
| TYPE IV BUNKER | - - - - - | 20-21 |

U.S. ARMY MATERIEL COMMAND DRAWING

| | | | | | | | | | | | | | | | | | | | | | | | | | | | | | | | | | | |
|----------------------------------------------------------------------------------------------------------------------------------------------------------------------------------------------------------------------------------------------------------------------------------------------------------------------------------------------|-----------------------------------------------------------------------------------------------------------------------------------------------------------------------------------------------------------------------------------------------------------------------------------------------------------------------------------------------|--------------------------------|-------------------------|-----------------|--|--|---------------------|--|--|----------------------------------------------------------------------------------------------------------------------------------------------------------------------------------------------------------------------------------------------------------------------------------------------------------------------------------------------------------------------------------------------------------------------------------------------------------------------------------------------------------------------------------------|------------------------------------|-----------------------------|--|--|------------------------------|----------------------------|--|--|----------------------------|-----------|--|--|---------------------------------------------|--------------------------------|--|--|---------------------------------------------------------------------------------------------------------------------------------------------------------------------------------------------------------------------------------------------------------------------------------------------------------------------------------------------------------------------------------------------------------------------------------------------------------------------------------------------------------------------------|----------------------|-------------------------|------------------------|---------------------|-----------|-----------|-------------|
| <p style="text-align: center;">APPROVED, U.S. ARMY AVIATION AND MISSILE COMMAND</p> <p>OCONNOR.DOUGLAS.LEO.114058225 1</p> <p><small>Digitally signed by OCONNOR.DOUGLAS.LEO.114 0582251 Date: 2018.02.12 15:42:52 -06'00'</small></p> | <p>CAUTION: VERIFY PRIOR TO USE AT HTTPS://MHP.REDSTONE.ARMY.MIL THAT THIS IS THE MOST CURRENT VERSION OF THIS DOCUMENT. THIS IS PAGE 1 OF 22.</p> | | | | | | | | | | | | | | | | | | | | | | | | | | | | | | | | | |
| <p style="text-align: center;">APPROVED BY ORDER OF COMMANDING GENERAL, U.S. ARMY MATERIEL COMMAND</p> <p>SHIMP.UPTON.R.1231257183</p> <p><small>Digitally signed by SHIMP.UPTON.R.1231257183 Date: 2018.02.13 08:46:32 -06'00'</small></p> <p style="text-align: center;">U.S. ARMY DEFENSE AMMUNITION CENTER</p> | <p>DO NOT SCALE</p> | <p>FEBRUARY 2018</p> | | | | | | | | | | | | | | | | | | | | | | | | | | | | | | | | |
| | <table border="1" style="width: 100%; border-collapse: collapse;"> <tr> <td style="width: 20%;"><small>DESIGN ENGINEER</small></td> <td style="width: 10%;"><small>BASIC</small></td> <td colspan="2" style="text-align: center;">RICHARD GARSIDE</td> </tr> <tr> <td></td> <td><small>REV.</small></td> <td colspan="2"></td> </tr> </table> | <small>DESIGN ENGINEER</small> | <small>BASIC</small> | RICHARD GARSIDE | | | <small>REV.</small> | | | <table border="1" style="width: 100%; border-collapse: collapse;"> <tr> <td style="width: 25%;"><small>ENGINEERING DIVISON</small></td> <td colspan="3">FIEFFER.LAUR A.A.1230375727</td> </tr> <tr> <td><small>TEST ENGINEER</small></td> <td colspan="3">FELICIANO.AD IN.1259200373</td> </tr> <tr> <td><small>TEST REPORT</small></td> <td colspan="3" style="text-align: center;">NA</td> </tr> <tr> <td><small>EXPLOSIVE SAFETY DIRECTORATE</small></td> <td colspan="3">THOMAS.CARL.ANTHONY.1104621372</td> </tr> </table> | <small>ENGINEERING DIVISON</small> | FIEFFER.LAUR A.A.1230375727 | | | <small>TEST ENGINEER</small> | FELICIANO.AD IN.1259200373 | | | <small>TEST REPORT</small> | NA | | | <small>EXPLOSIVE SAFETY DIRECTORATE</small> | THOMAS.CARL.ANTHONY.1104621372 | | | <table border="1" style="width: 100%; border-collapse: collapse;"> <tr> <td style="width: 15%;"><small>CLASS</small></td> <td style="width: 15%;"><small>DIVISION</small></td> <td style="width: 15%;"><small>DRAWING</small></td> <td style="width: 15%;"><small>FILE</small></td> </tr> <tr> <td style="text-align: center;">19</td> <td style="text-align: center;">48</td> <td style="text-align: center;">5277</td> <td style="text-align: center;">GM1-3-4-14-22TH2</td> </tr> </table> | <small>CLASS</small> | <small>DIVISION</small> | <small>DRAWING</small> | <small>FILE</small> | 19 | 48 | 5277 |
| <small>DESIGN ENGINEER</small> | <small>BASIC</small> | RICHARD GARSIDE | | | | | | | | | | | | | | | | | | | | | | | | | | | | | | | | |
| | <small>REV.</small> | | | | | | | | | | | | | | | | | | | | | | | | | | | | | | | | | |
| <small>ENGINEERING DIVISON</small> | FIEFFER.LAUR A.A.1230375727 | | | | | | | | | | | | | | | | | | | | | | | | | | | | | | | | | |
| <small>TEST ENGINEER</small> | FELICIANO.AD IN.1259200373 | | | | | | | | | | | | | | | | | | | | | | | | | | | | | | | | | |
| <small>TEST REPORT</small> | NA | | | | | | | | | | | | | | | | | | | | | | | | | | | | | | | | | |
| <small>EXPLOSIVE SAFETY DIRECTORATE</small> | THOMAS.CARL.ANTHONY.1104621372 | | | | | | | | | | | | | | | | | | | | | | | | | | | | | | | | | |
| <small>CLASS</small> | <small>DIVISION</small> | <small>DRAWING</small> | <small>FILE</small> | | | | | | | | | | | | | | | | | | | | | | | | | | | | | | | |
| 19 | 48 | 5277 | GM1-3-4-14-22TH2 | | | | | | | | | | | | | | | | | | | | | | | | | | | | | | | |

GENERAL NOTES

- A. THIS DOCUMENT HAS BEEN PREPARED AND ISSUED IN ACCORDANCE WITH AR 740-1 AND AUGMENTS TM 743-200-1 (CHAPTER 5).
- B. THE STORAGE PROCEDURES DEPICTED WITHIN THIS DOCUMENT ARE APPLICABLE FOR STORAGE IN APPROVED MAGAZINES. MINOR ADJUSTMENTS MAY BE MADE TO FACILITATE LOCAL STORAGE CONDITIONS; HOWEVER, THE BASIC PRINCIPLES AS DEPICTED HEREIN WILL BE FOLLOWED.
- C. THE STORAGE PROCEDURES SPECIFIED IN THIS DRAWING ARE APPLICABLE TO THAAD MISSILE PACKED IN SMRTC. SUBSEQUENT REFERENCE TO CONTAINER HEREIN MEANS SMRTC WITH THAAD MISSILE. SEE PAGE 3 AND LOCKHEED MARTIN DRAWING 13640484 FOR DETAILS OF THE SMRTC.
- D. **CAUTION:** THESE ITEMS ARE IN A "PROPULSIVE STATE" AND MUST BE STORED WITH THE FORWARD END FACING TOWARD THE REAR WALL OR A SIDE WALL OF THE MAGAZINE NOT TOWARD THE DOOR/FRONT WALL.
- E. **CAUTION:** THE ALLOWABLE "EXPLOSIVE LIMIT" ESTABLISHED FOR A MAGAZINE IS NOT TO BE EXCEEDED. THIS LIMITATION MAY REQUIRE A QUANTITY REDUCTION FROM THE STORAGE AS SHOWN.
- F. STORED CONTAINERS MUST NOT CONTACT THE SIDES OF A MAGAZINE. THEREFORE, UNITS MUST BE STORED A MINIMUM OF 6" FROM THE SIDEWALL OR CURVATURE OF THE MAGAZINE AS APPLICABLE. TO PROVIDE FOR THIS MANDATORY CLEARANCE REQUIREMENT, UNITS MAY BE ELIMINATED FROM THE DEPICTED STORAGE PATTERN AS NECESSARY.
- G. A 48" MINIMUM INSPECTION DISTANCE MUST BE MAINTAINED AT THE END OF THE CONTAINERS WHERE HUMIDITY INDICATORS ARE LOCATED, IN ORDER TO CHANGE THE DESSICANT.
- H. THE MAXIMUM FLOOR LOAD FOR THE MAGAZINE AS PRESCRIBED WILL NOT BE EXCEEDED.
- J. **CAUTION:** CONTAINERS MUST NOT BE STACKED IN MAGAZINES.
- K. WHEN LOCAL STORAGE CONDITIONS ARE SUCH THAT AN AMMUNITION STORAGE MAGAZINE NET EXPLOSIVE WEIGHT LIMIT WILL BE REACHED BEFORE ALL AVAILABLE STORAGE SPACE WILL BE UTILIZED, A COMBINATION OF THE VARIOUS STORAGE PATTERNS DELINEATED HEREIN MAY BE USED IN LIEU OF DESIGNATED STORAGE PATTERNS TO FACILITATE INVENTORY, INSPECTION, THE USE OF MATERIAL HANDLING EQUIPMENT, SURVEILLANCE, ETC., OF THE CONTAINERS TO BE STORED WITHIN THE MAGAZINE.
- L. TO FACILITATE MOVEMENT OF THE CONTAINERS THROUGH NARROW DOOR OPENINGS OF MOST TYPES OF STORAGE MAGAZINES, AND TO AID WITH MOVEMENT INSIDE MAGAZINES, USE SIDE LOADING FORKLIFTS AND/OR STORAGE HANDLING AIDS, SUCH AS APPROVED HYDRAULIC LIFT CASTERS.
- M. CONTAINERS PRESENTLY STORED IN ACCORDANCE WITH A PRIOR APPROVED DRAWING NEED NOT BE RESTORED SOLELY TO CONFORM TO THE PROCEDURES SPECIFIED IN THIS DOCUMENT.
- N. OTHER COMPATIBLE ITEMS MAY BE STORED IN THE MAGAZINE, WHICH IS PARTIALLY FILLED WITH THE DESIGNATED ITEM.
- O. PORTIONS OF THE MAGAZINE, SUCH AS SIDEWALLS, ENDWALLS, AND ROOFS, HAVE NOT BEEN SHOWN IN THE STORAGE VIEWS FOR CLARITY PURPOSES.
- P. CONVERSION TO METRIC EQUIVALENTS: DIMENSIONS WITHIN THIS DOCUMENT ARE EXPRESSED IN INCHES, AND WEIGHTS ARE EXPRESSED IN POUNDS. WHEN NECESSARY, THE METRIC EQUIVALENT MAY BE COMPUTED ON THE BASIS OF ONE INCH EQUALS 25.4MM AND ONE POUND EQUALS 0.454 KG.

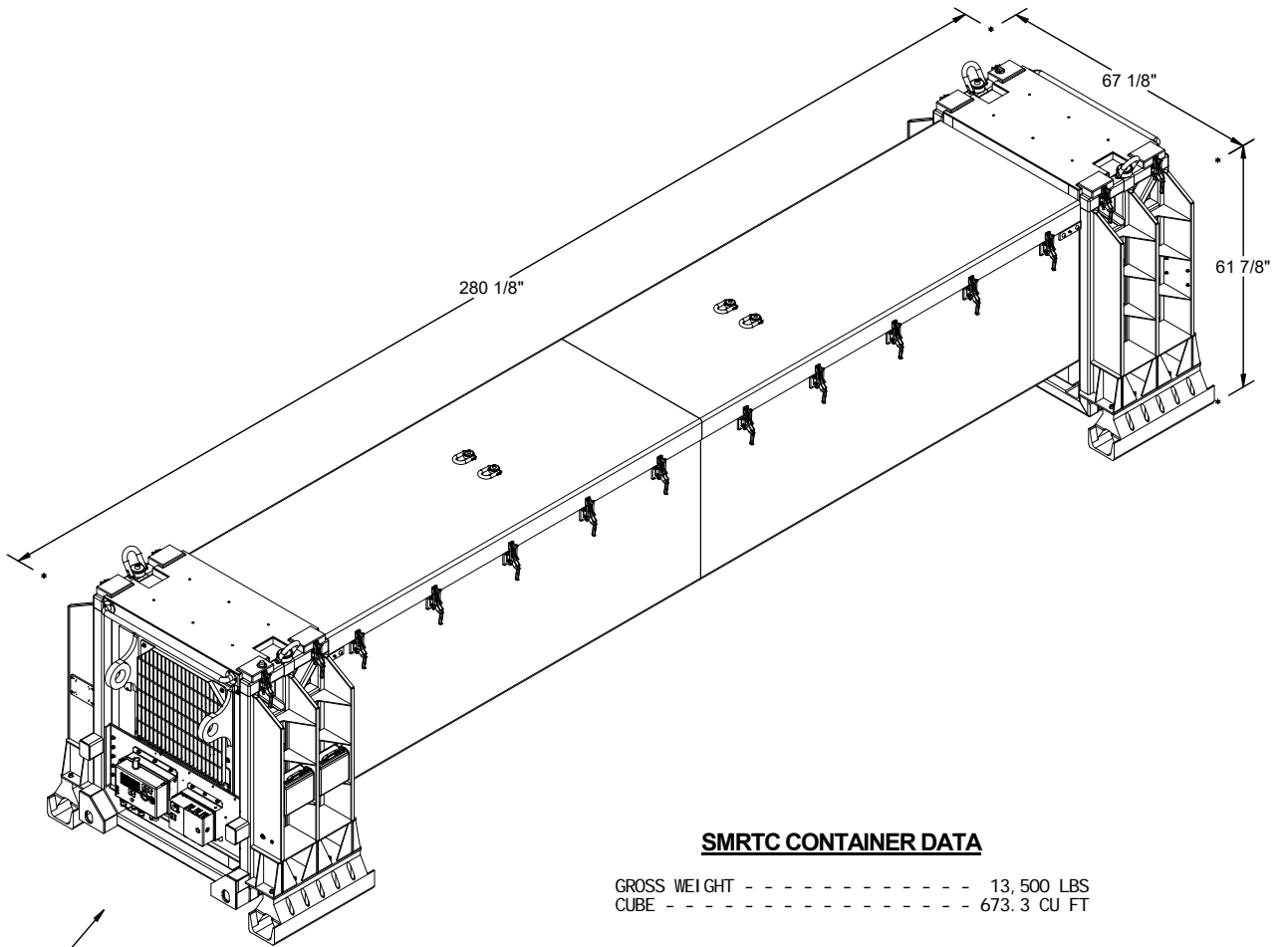

INDICATES AFT
END OF CONTAINER

SMRTC CONTAINER DATA

GROSS WEIGHT - - - - - 13,500 LBS
 CUBE - - - - - 673.3 CU FT

**STORAGE IN ARCH TYPE
MAGAZINE**

| ITEM | QUANTITY |
|----------------|----------|
| CONTAINER----- | 6 |

ARROW INDICATES FORWARD END OF CONTAINER.
SEE GENERAL NOTE "D" ON PAGE 2.

INSPECTION AISLE. SEE GENERAL NOTE "G" ON PAGE 2.

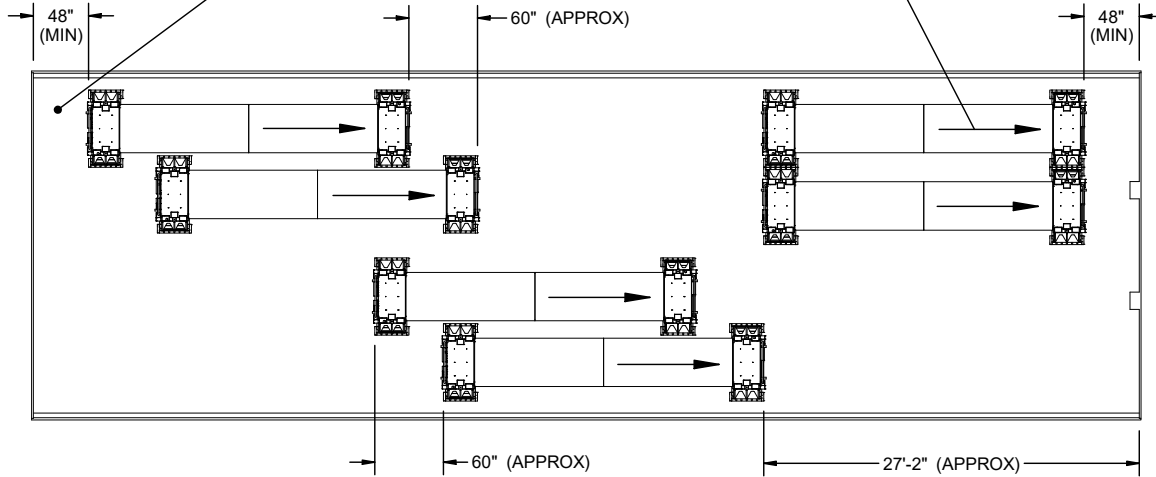

PLAN VIEW

SEE GENERAL
NOTE "F" ON
PAGE 2.

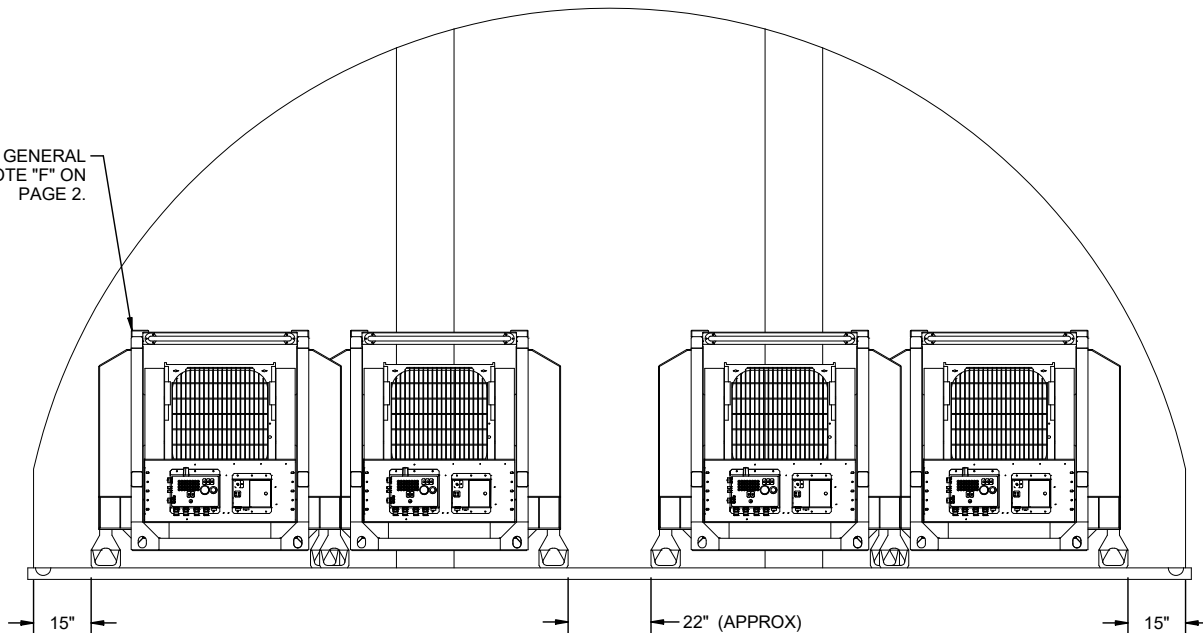

END VIEW

ARROW INDICATES FORWARD END OF CONTAINER.
SEE GENERAL NOTE "D" ON PAGE 2.

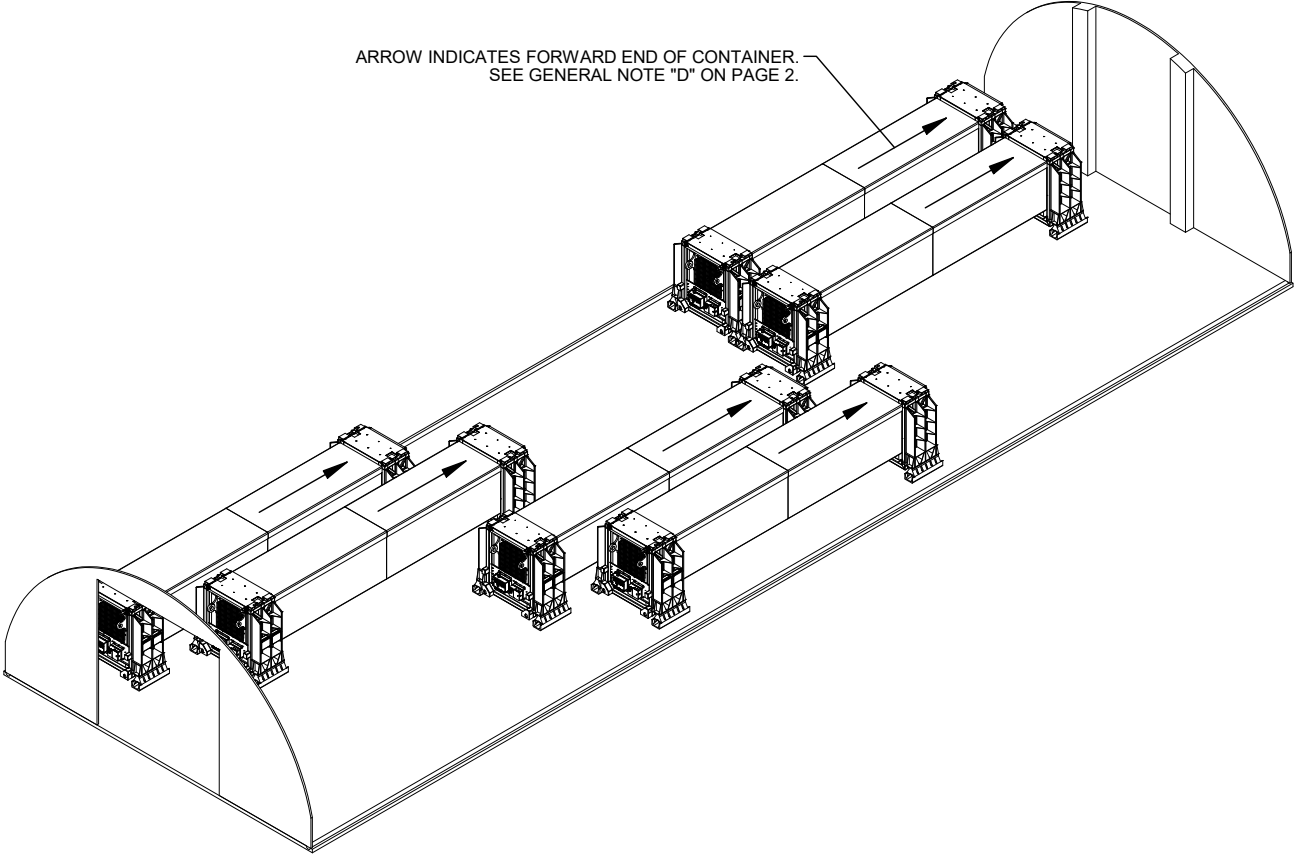

ISOMETRIC VIEW

**STORAGE IN IGLOO
MAGAZINE**

| ITEM | QUANTITY |
|----------------|----------|
| CONTAINER----- | 6 |

ARROW INDICATES FORWARD END OF CONTAINER.
SEE GENERAL NOTE "D" ON PAGE 2.

INSPECTION AISLE. SEE GENERAL NOTE "G" ON PAGE 2.

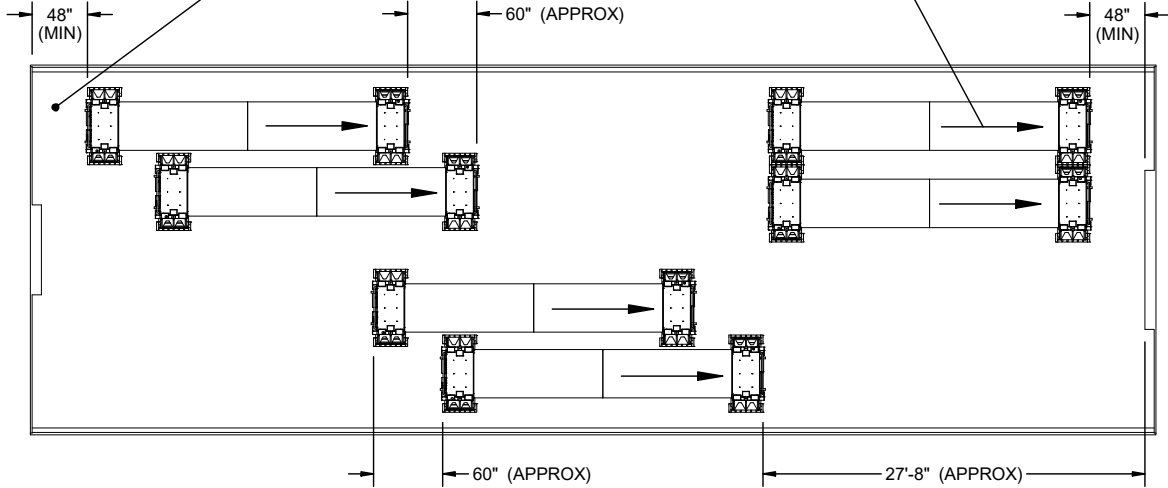

PLAN VIEW

SEE GENERAL
NOTE "F" ON
PAGE 2.

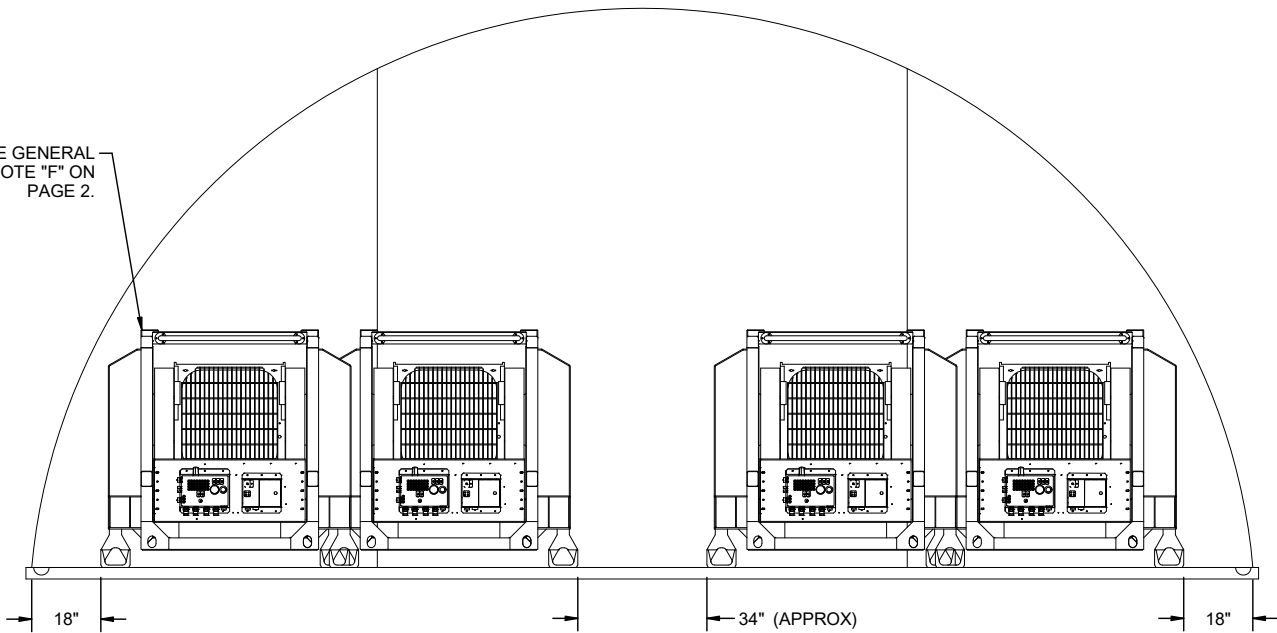

END VIEW

ARROW INDICATES FORWARD END OF CONTAINER.
SEE GENERAL NOTE "D" ON PAGE 2.

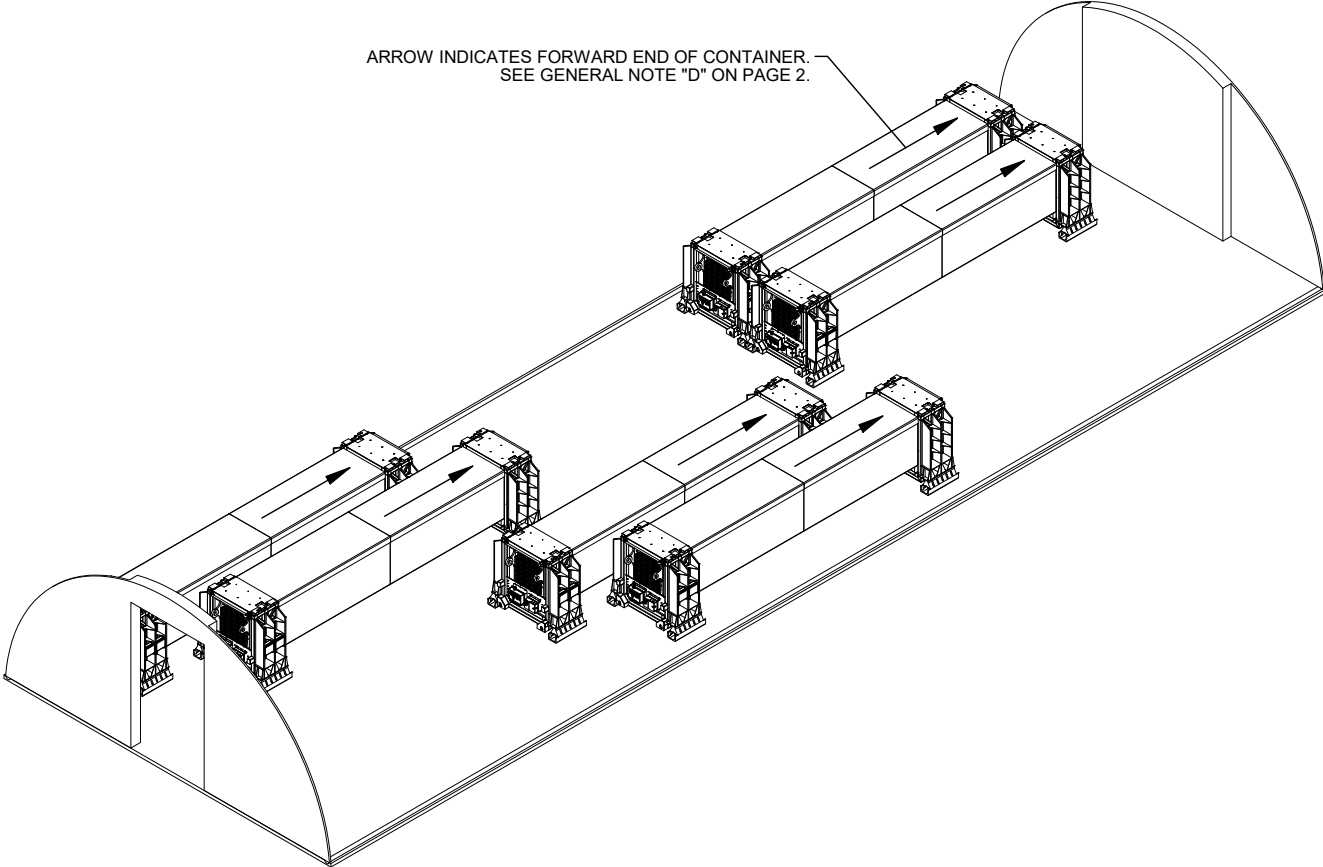

ISOMETRIC VIEW

**STORAGE IN 44'-7" CORBETTA
MAGAZINE**

| ITEM | QUANTITY |
|----------------|----------|
| CONTAINER----- | 6 |

INSPECTION AISLE. SEE
GENERAL NOTE "G" ON
PAGE 2.

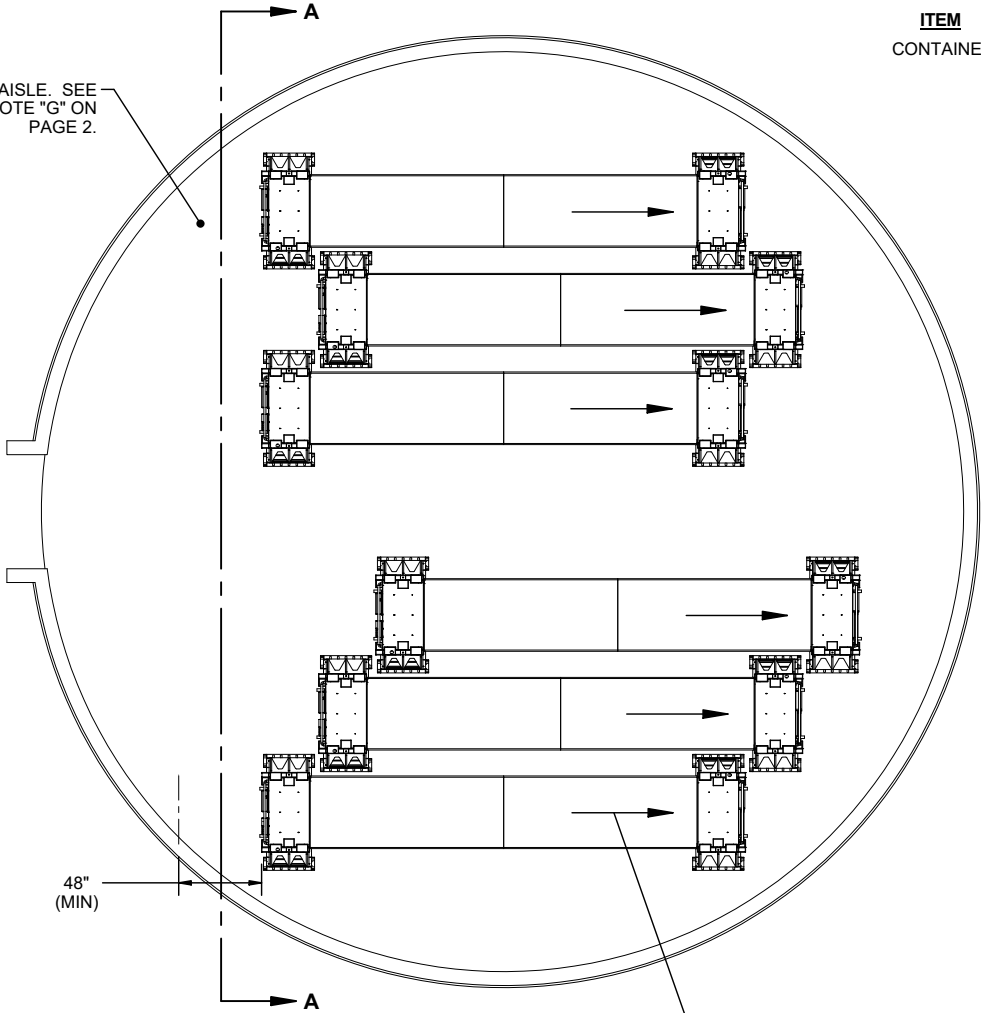

PLAN VIEW

ARROW INDICATES FORWARD END OF CONTAINER.
SEE GENERAL NOTE "D" ON PAGE 2.

SEE GENERAL
NOTE "F" ON
PAGE 2.

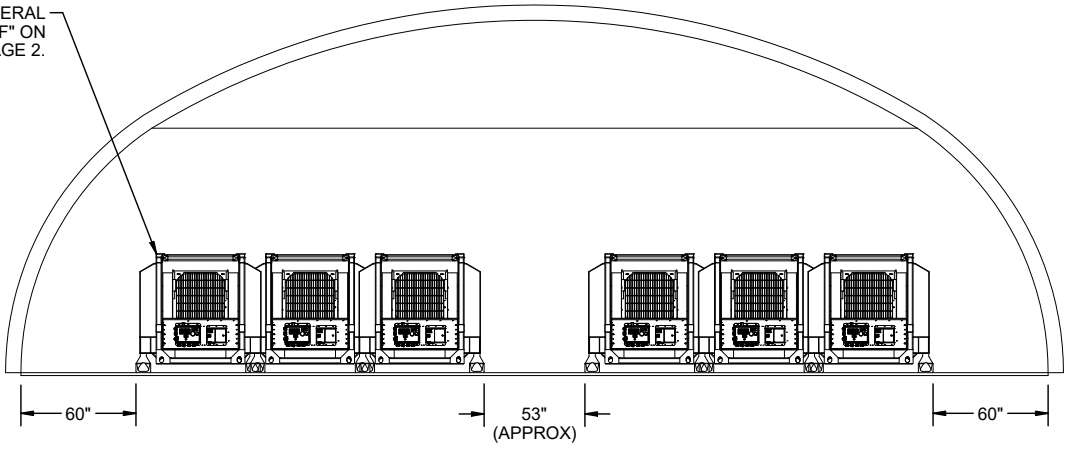

SECTION A-A

ARROW INDICATES FORWARD END
OF CONTAINER. SEE GENERAL
NOTE "D" ON PAGE 2.

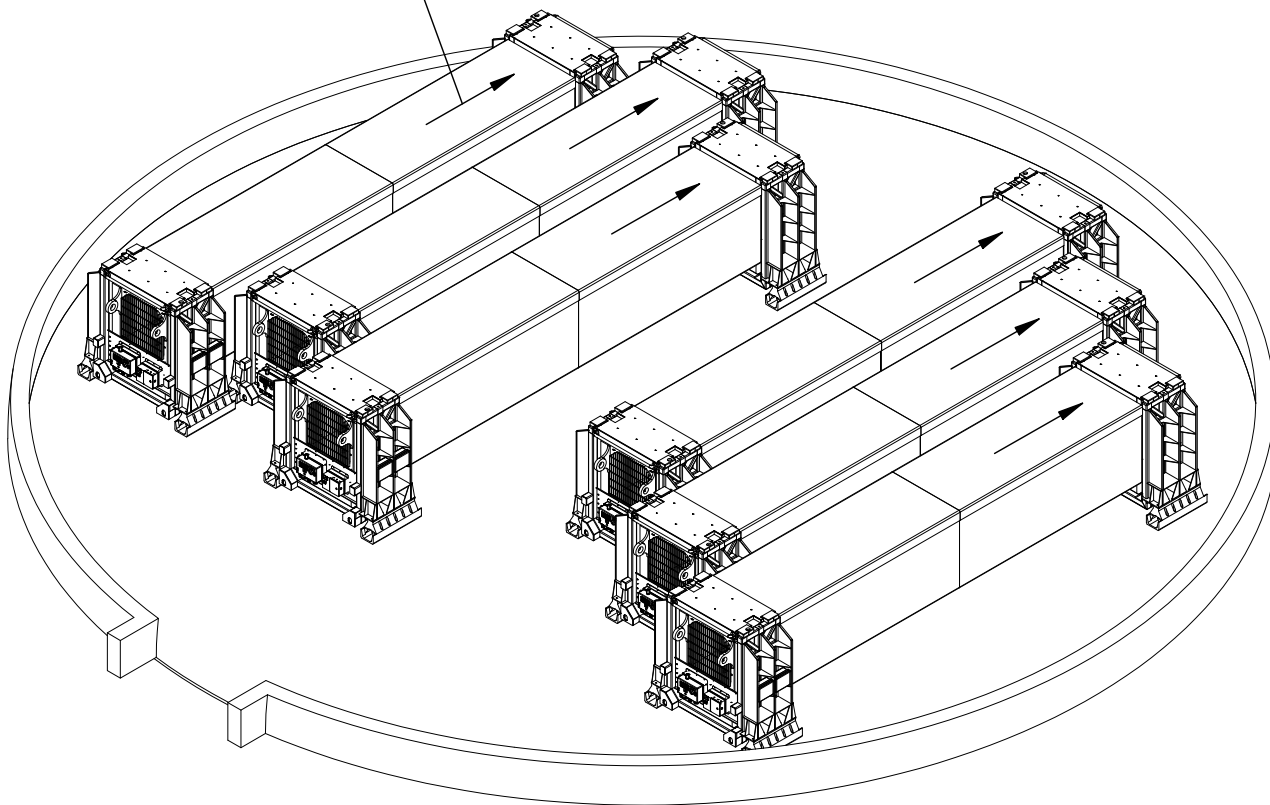

ISOMETRIC VIEW

**STORAGE IN 52'-0" CORBETTA
MAGAZINE**

| ITEM | QUANTITY |
|-----------|----------|
| CONTAINER | ----- 8 |

INSPECTION AISLE. SEE
GENERAL NOTE "G" ON
PAGE 2.

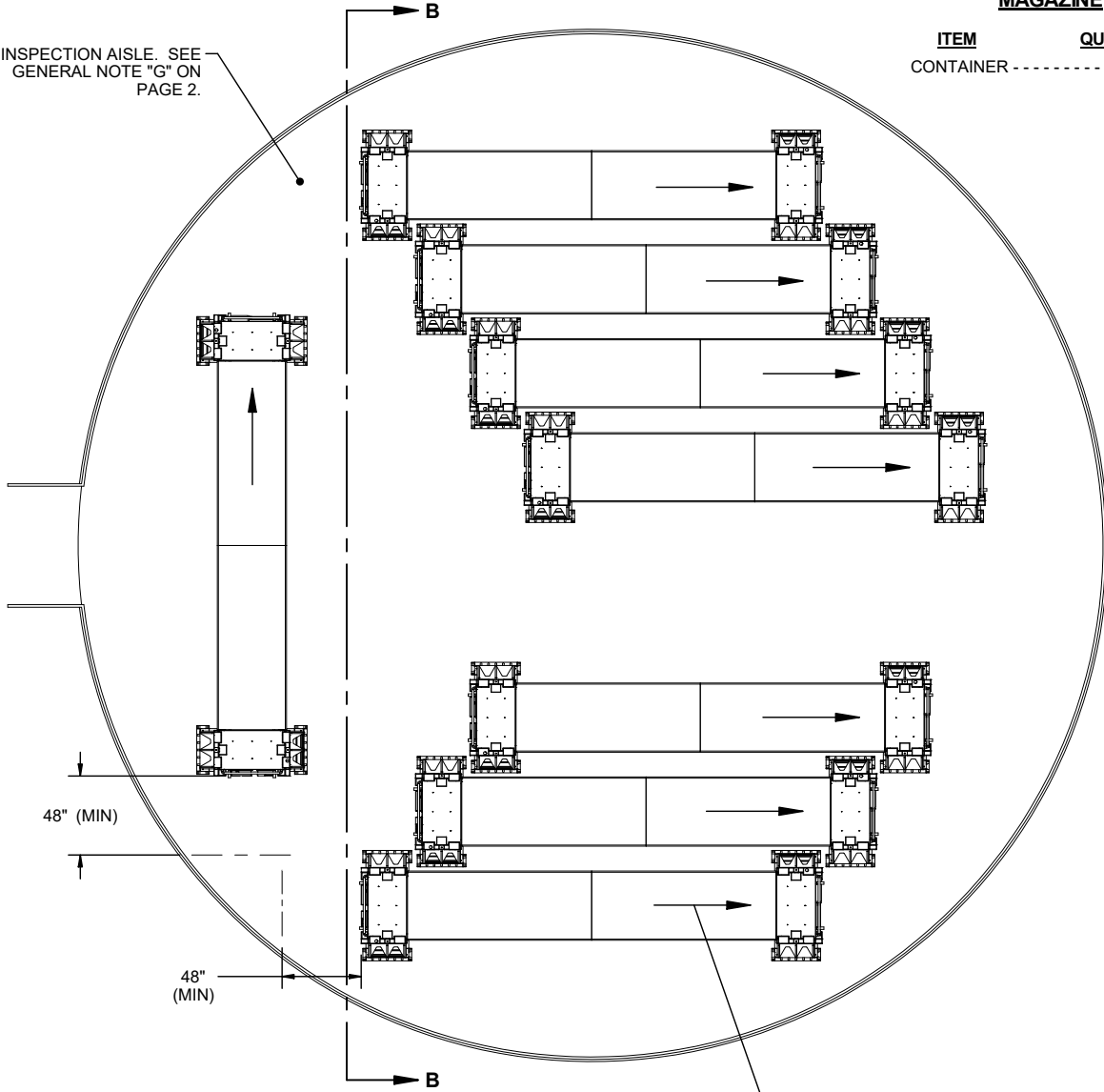

48" (MIN)

48" (MIN)

PLAN VIEW

ARROW INDICATES FORWARD
END OF CONTAINER. SEE
GENERAL NOTE "D" ON PAGE 2.

SEE GENERAL
NOTE "F" ON
PAGE 2.

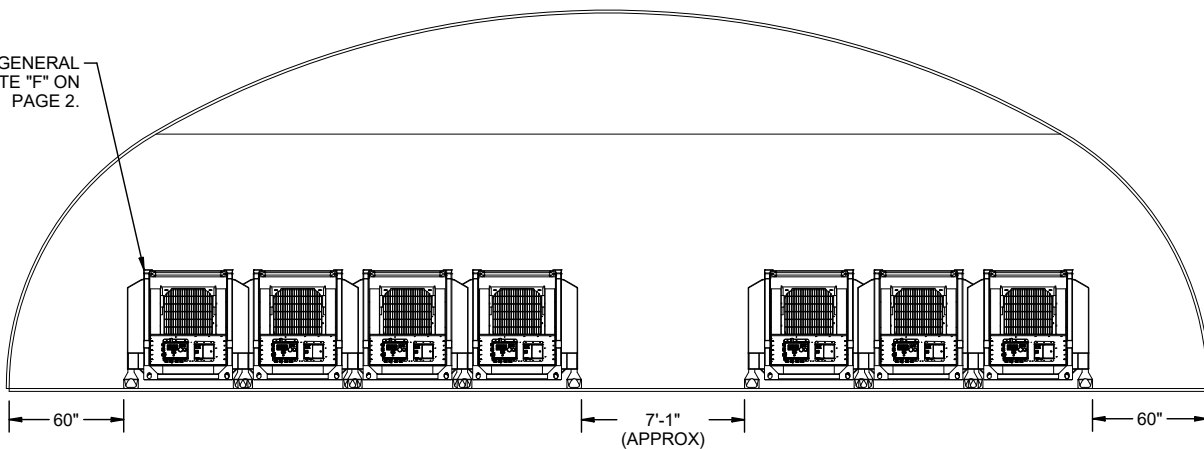

SECTION B-B

ARROW INDICATES FORWARD END
OF CONTAINER. SEE GENERAL
NOTE "D" ON PAGE 2.

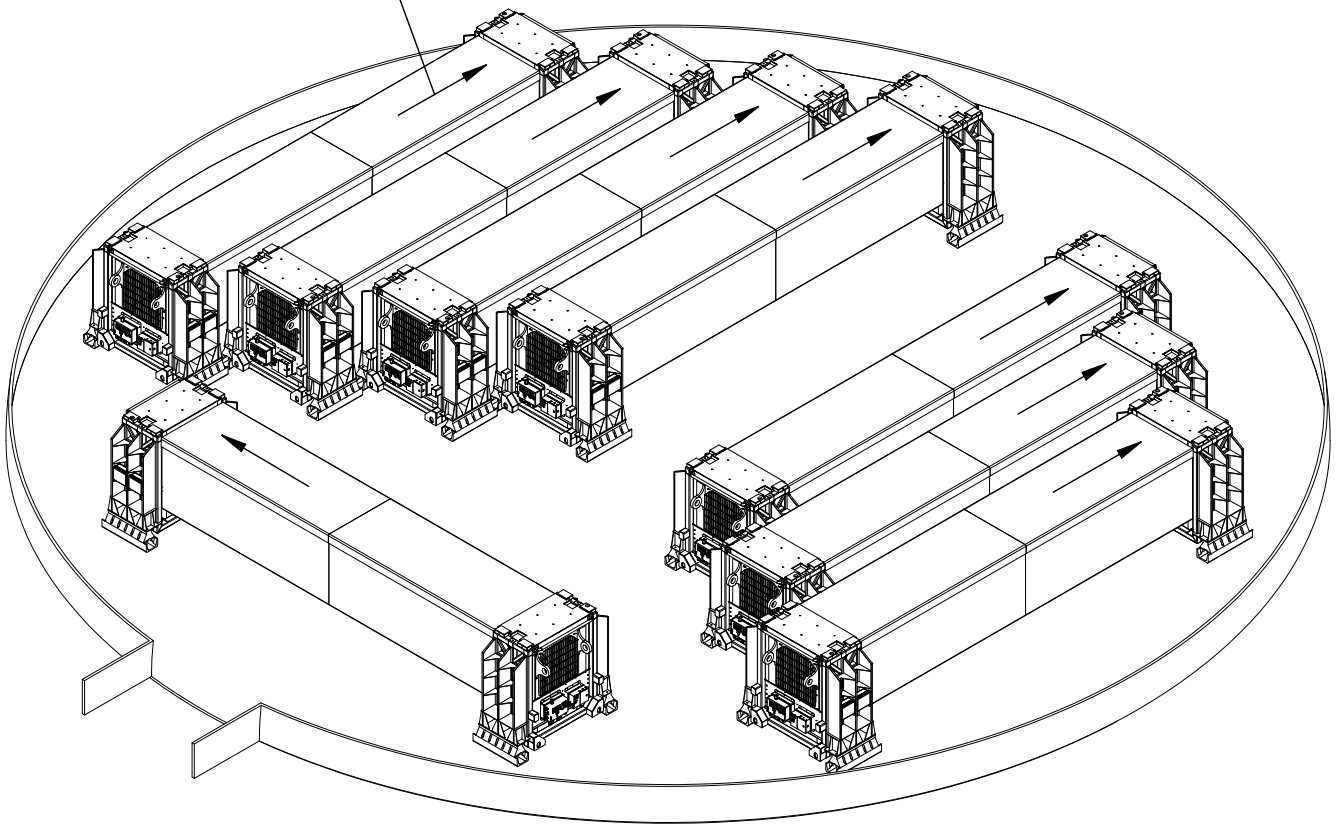

ISOMETRIC VIEW

**STORAGE IN OVAL ARCH
MAGAZINE**

| ITEM | QUANTITY |
|----------------|----------|
| CONTAINER----- | 8 |

ARROW INDICATES FORWARD END OF CONTAINER.
SEE GENERAL NOTE "D" ON PAGE 2.

INSPECTION AISLE. SEE
GENERAL NOTE "G" ON PAGE 2.

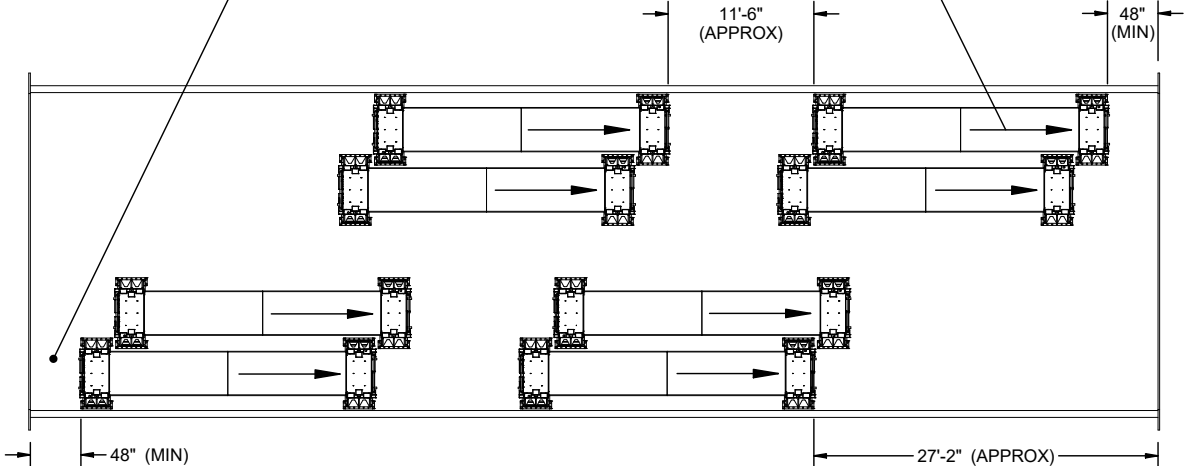

PLAN VIEW

SEE GENERAL
NOTE "F" ON
PAGE 2.

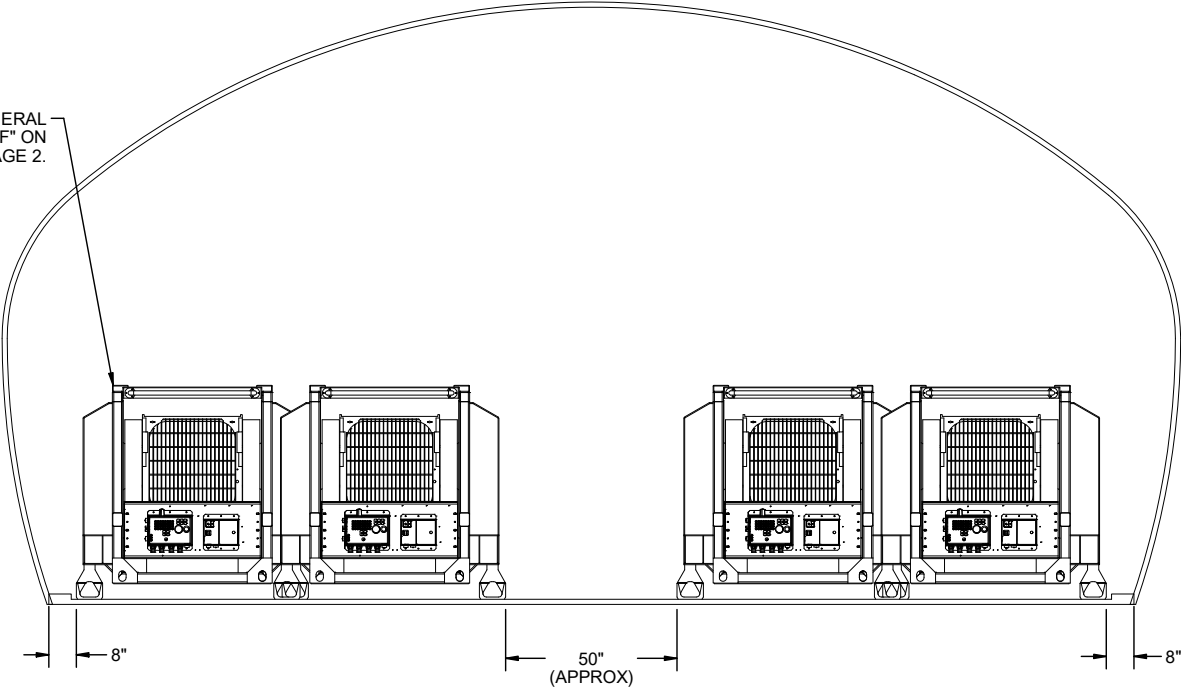

END VIEW

ARROW INDICATES FORWARD END OF CONTAINER.
SEE GENERAL NOTE "D" ON PAGE 2.

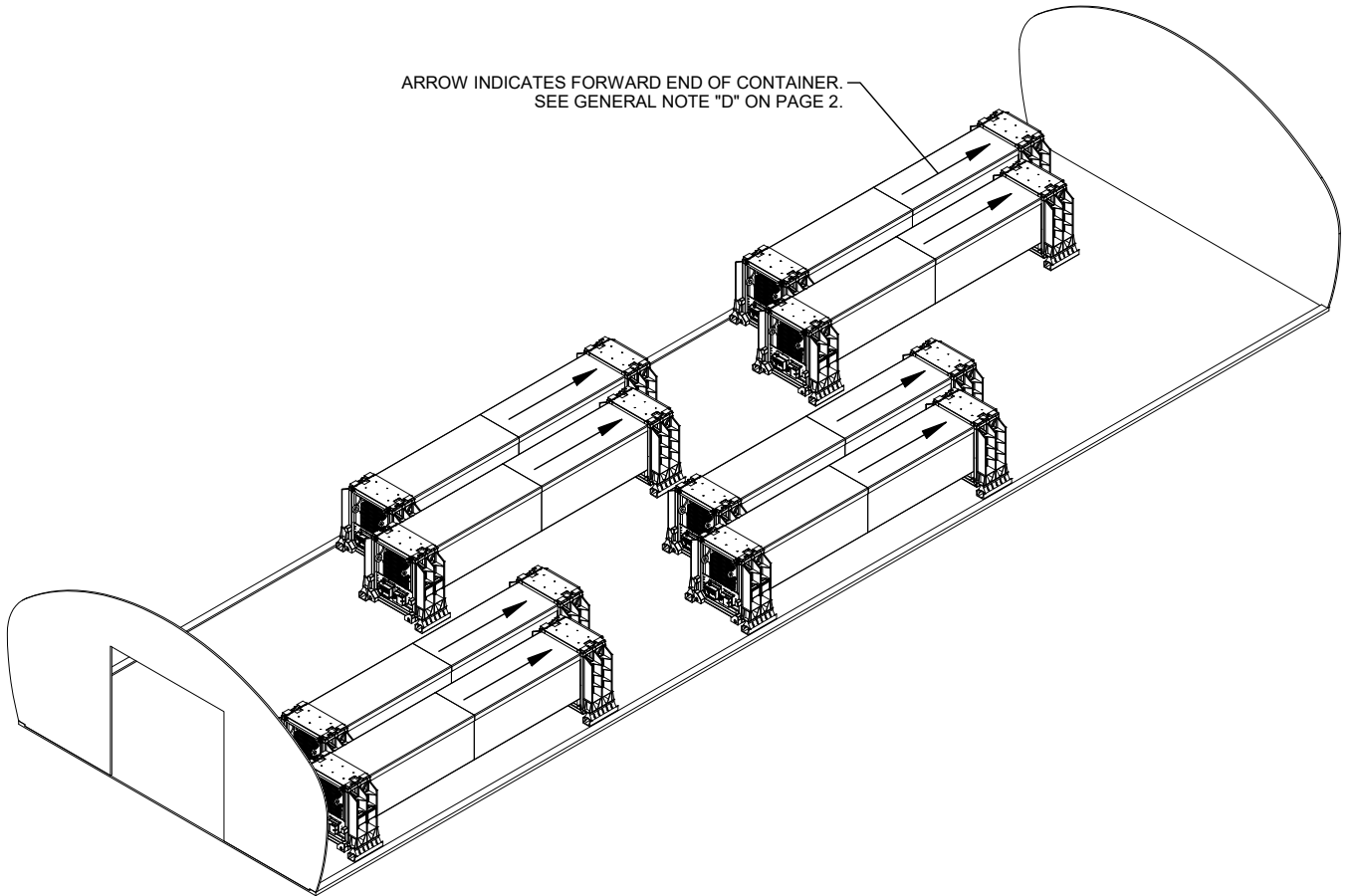

ISOMETRIC VIEW

**STORAGE IN STEEL ARCH
MAGAZINE**

| ITEM | QUANTITY |
|----------------|----------|
| CONTAINER----- | 4 |

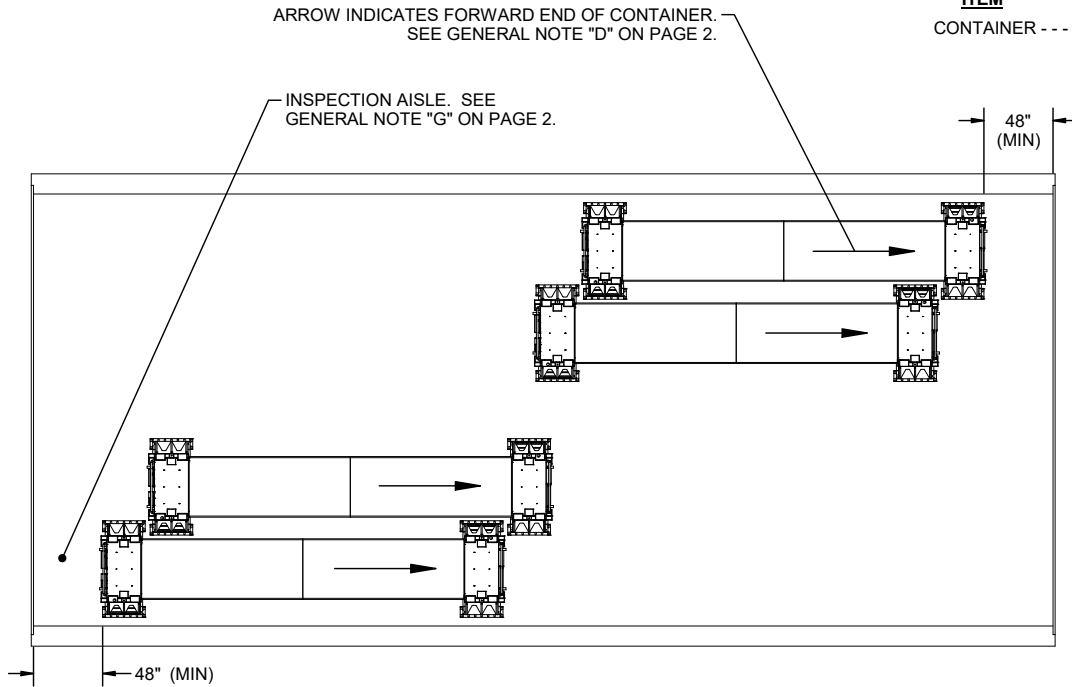

PLAN VIEW

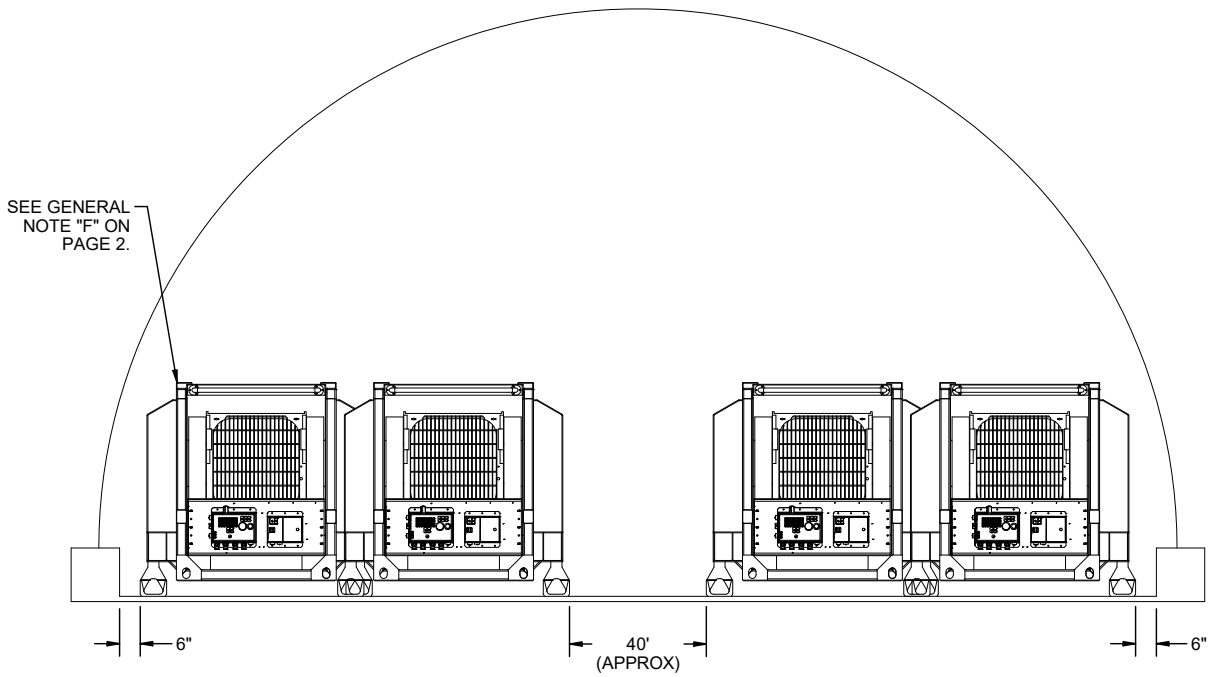

END VIEW

ARROW INDICATES FORWARD END OF CONTAINER.
SEE GENERAL NOTE "D" ON PAGE 2.

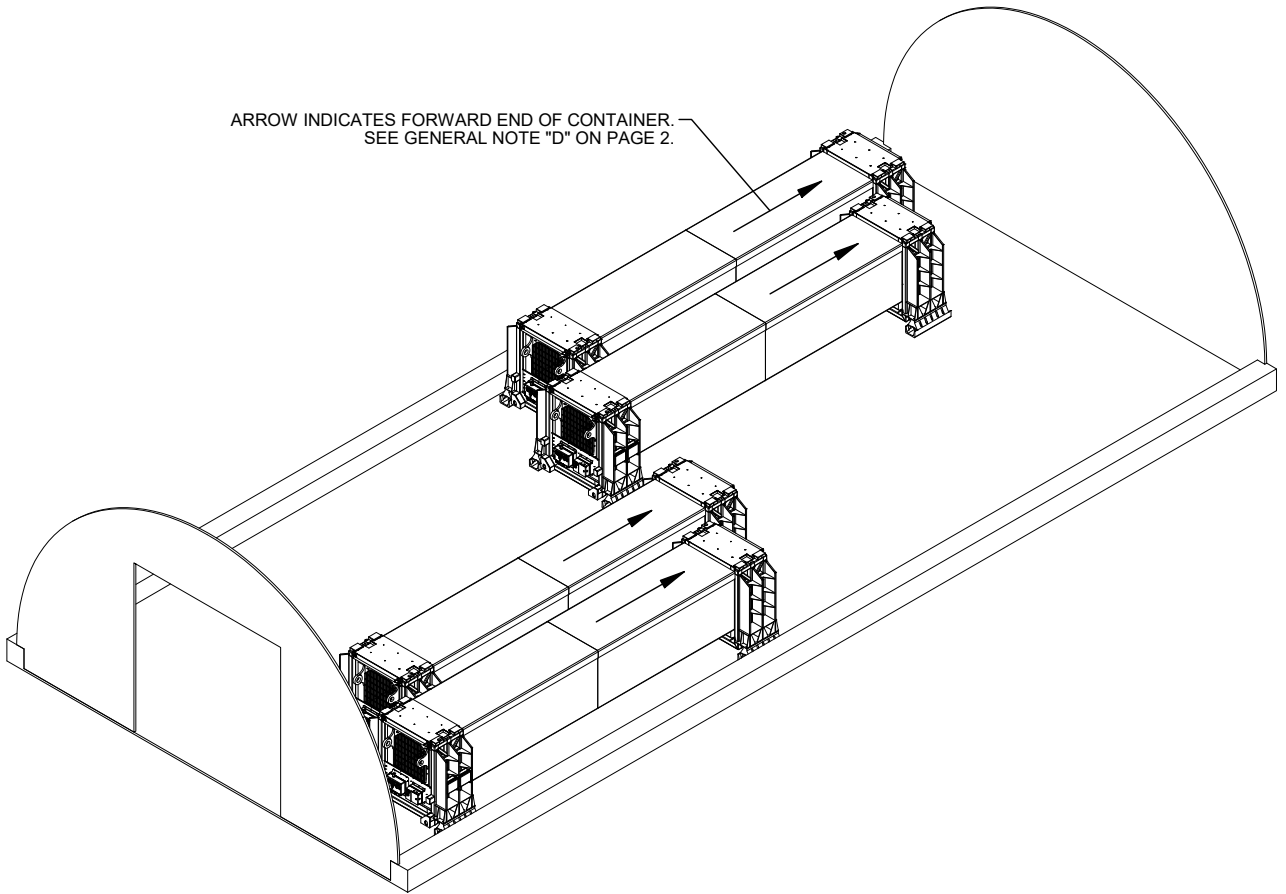

ISOMETRIC VIEW

**STORAGE IN TYPE II BUNKER
MAGAZINE**

ARROW INDICATES FORWARD END OF CONTAINER.
SEE GENERAL NOTE "D" ON PAGE 2.

| ITEM | QUANTITY |
|----------------|----------|
| CONTAINER----- | 12 |

INSPECTION AISLE. SEE GENERAL NOTE "G" ON PAGE 2.

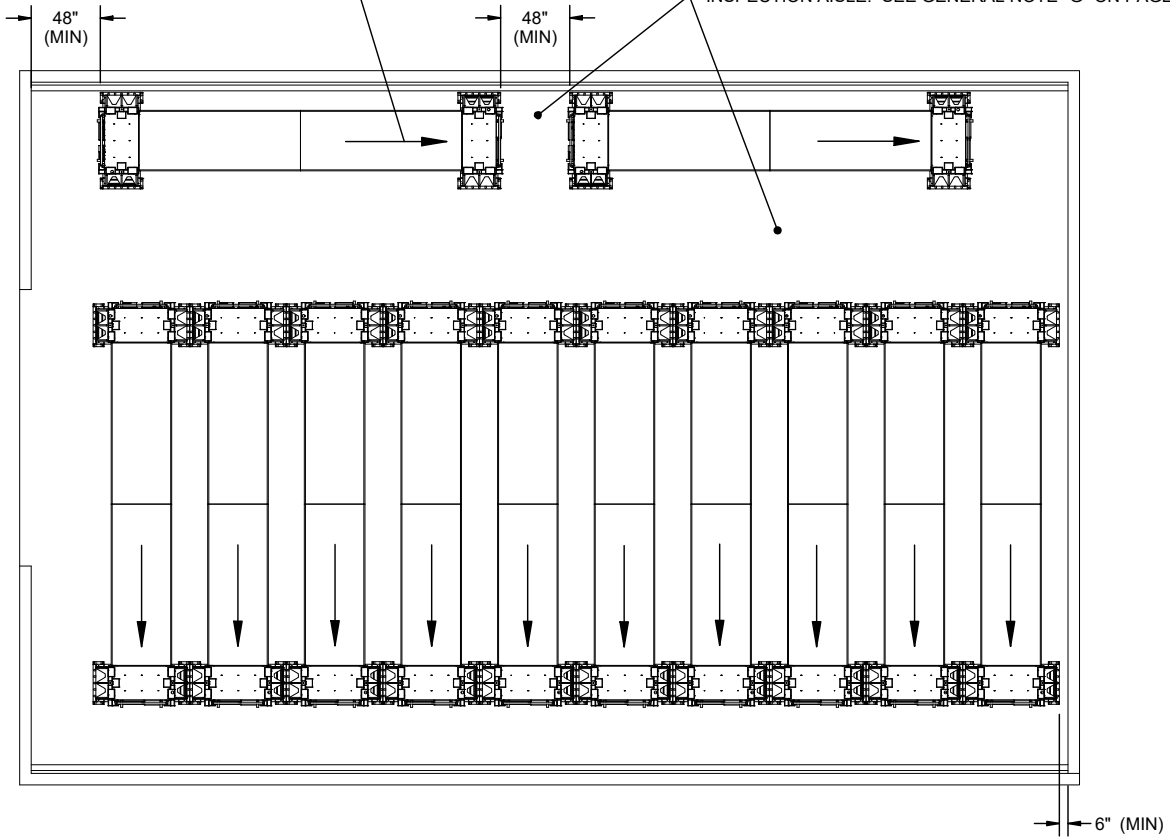

PLAN VIEW

SEE GENERAL NOTE "F" ON PAGE 2.

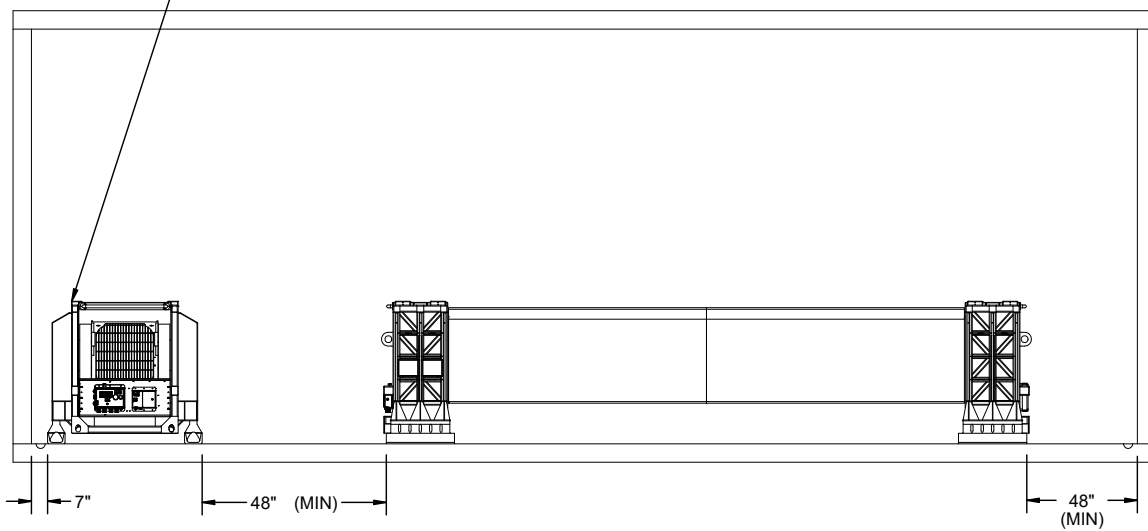

END VIEW

TYPE II BUNKER

ARROW INDICATES FORWARD END OF CONTAINER.
SEE GENERAL NOTE "D" ON PAGE 2.

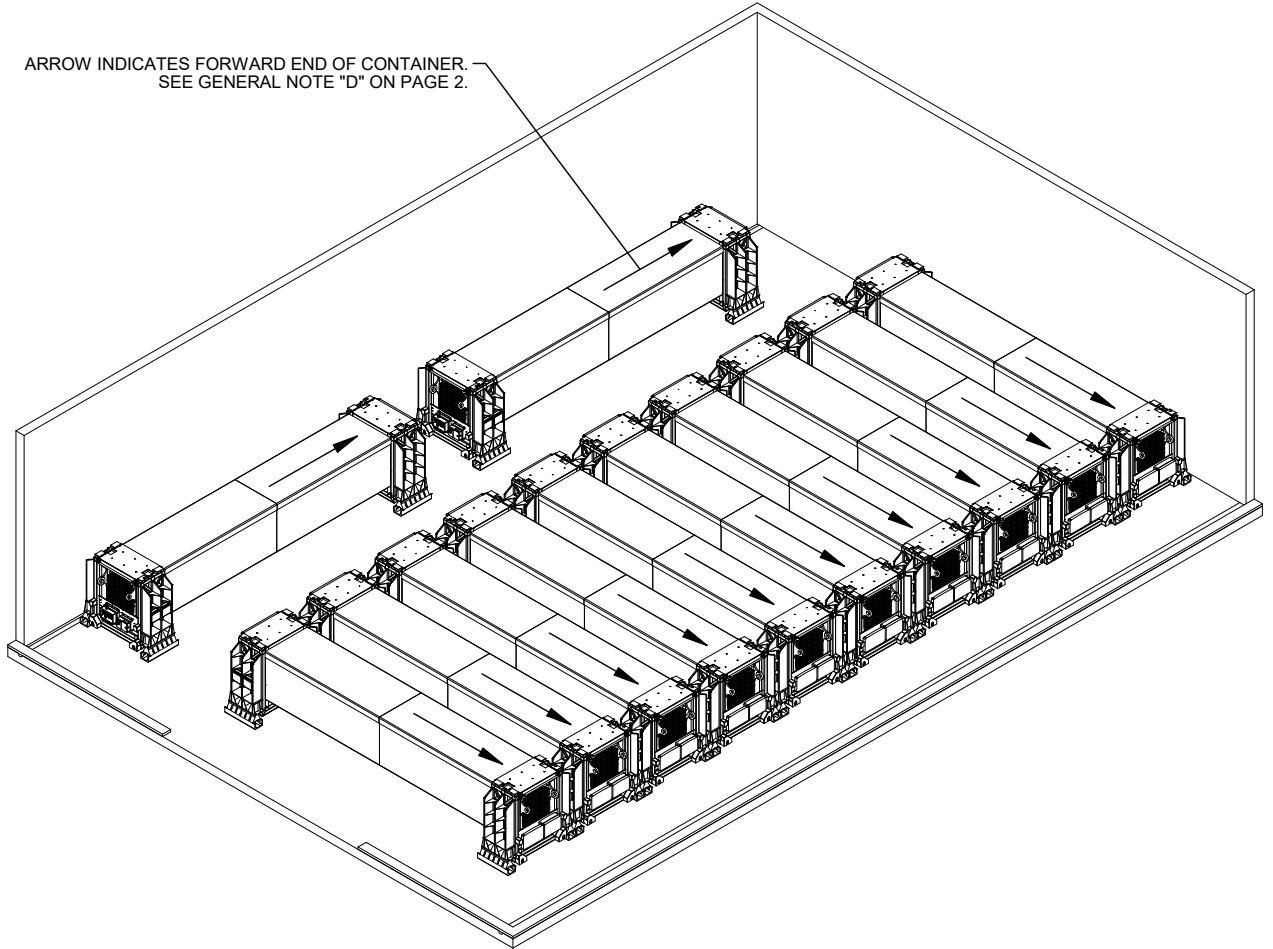

ISOMETRIC VIEW

**STORAGE IN TYPE III BUNKER
MAGAZINE**

ITEM **QUANTITY**
CONTAINER-----9

INSPECTION AISLE. SEE GENERAL
NOTE "G" ON PAGE 2.

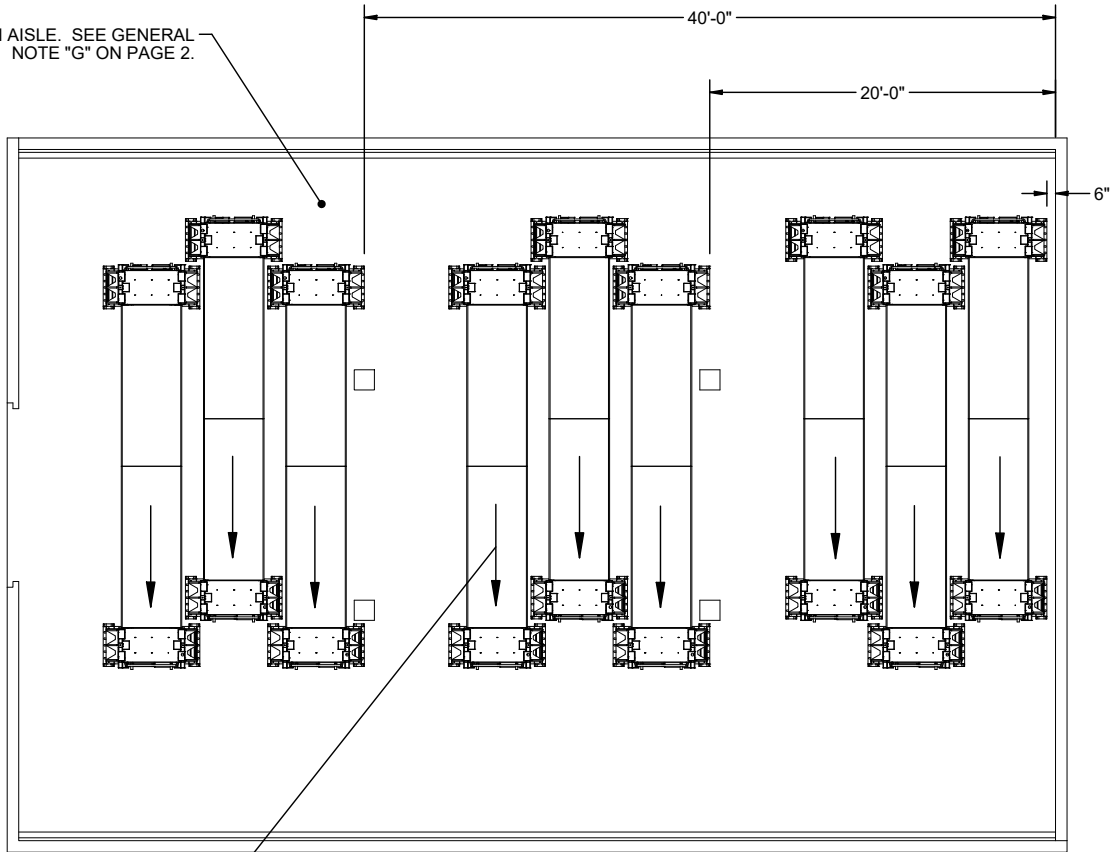

PLAN VIEW

ARROW INDICATES FORWARD
END OF CONTAINER. SEE
GENERAL NOTE "D" ON PAGE 2.

SEE GENERAL NOTE "F" ON PAGE 2.

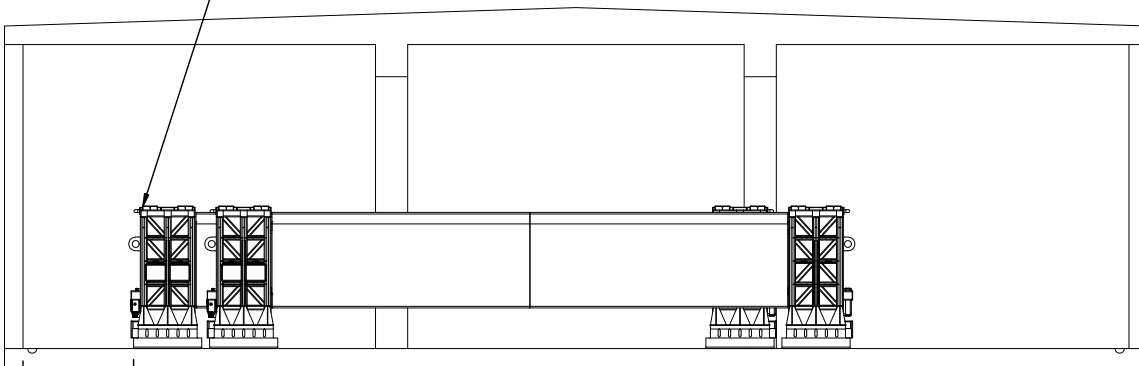

END VIEW

TYPE III BUNKER

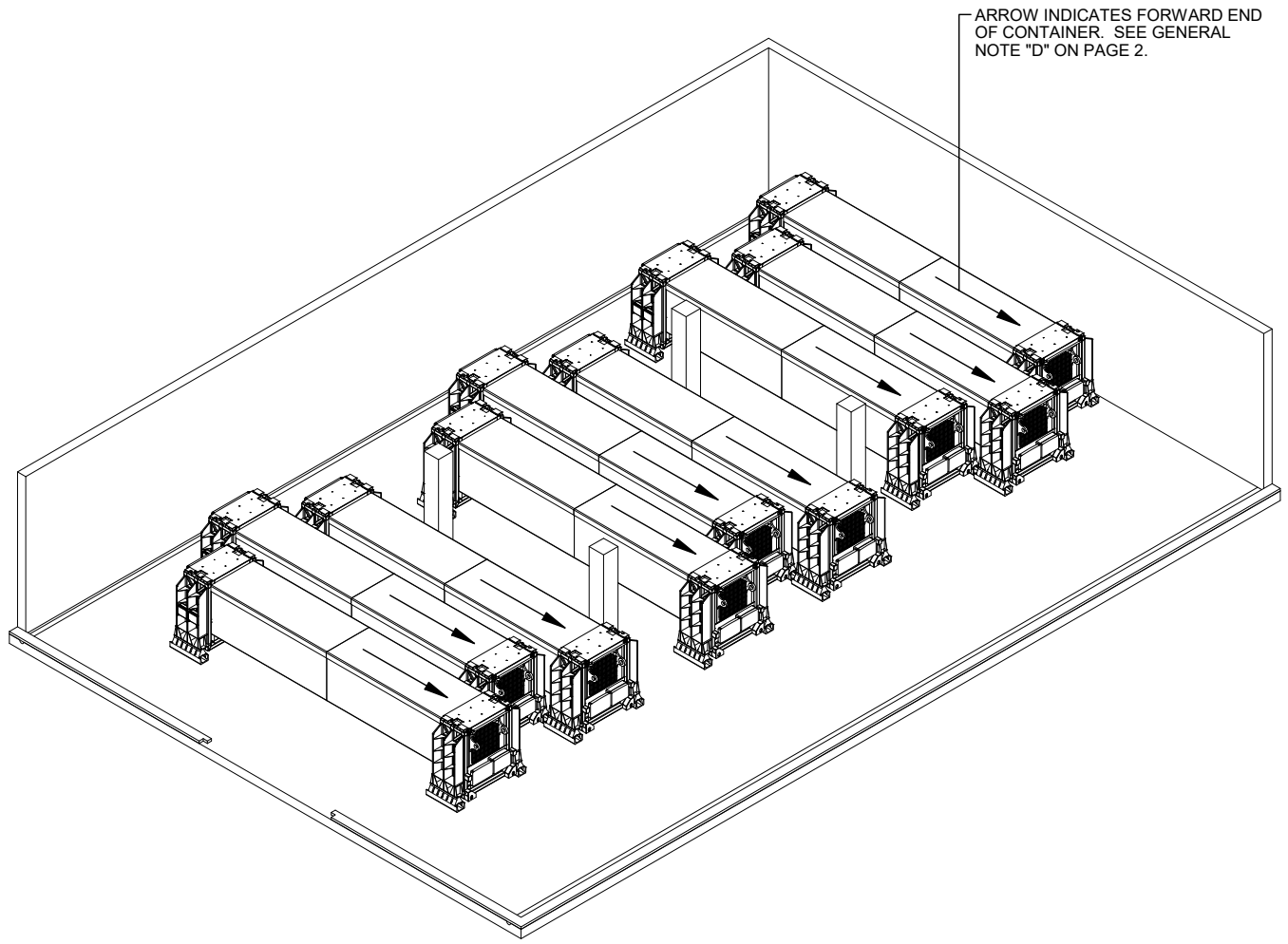

ARROW INDICATES FORWARD END OF CONTAINER. SEE GENERAL NOTE "D" ON PAGE 2.

ISOMETRIC VIEW

**STORAGE IN TYPE IV BUNKER
MAGAZINE**

| ITEM | QUANTITY |
|-----------------|----------|
| CONTAINER ----- | 3 |

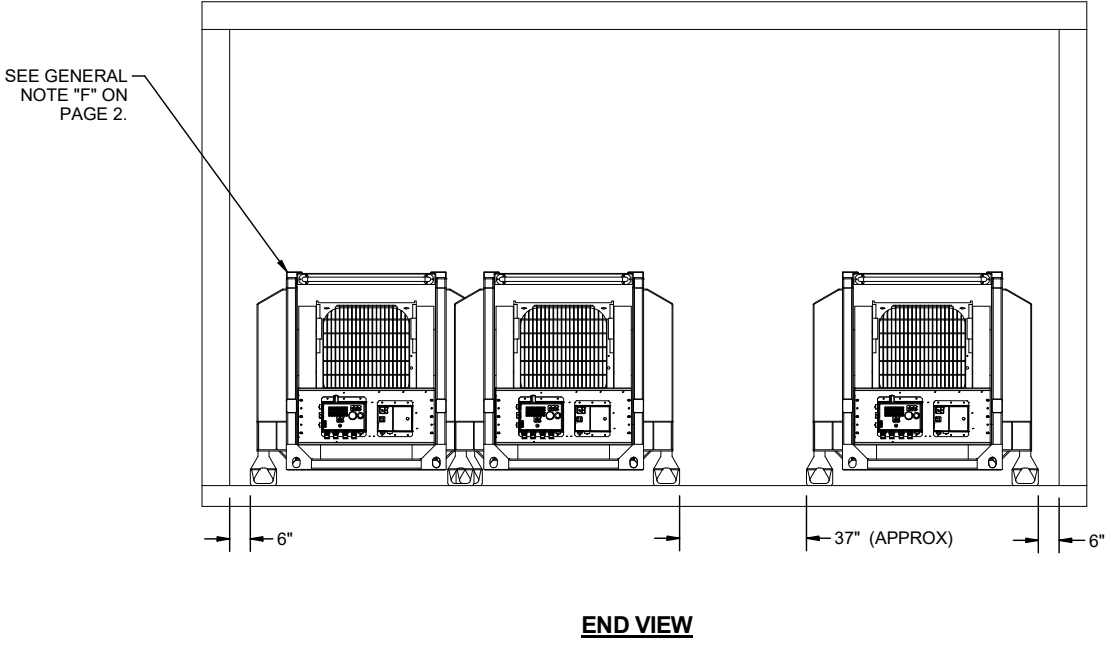
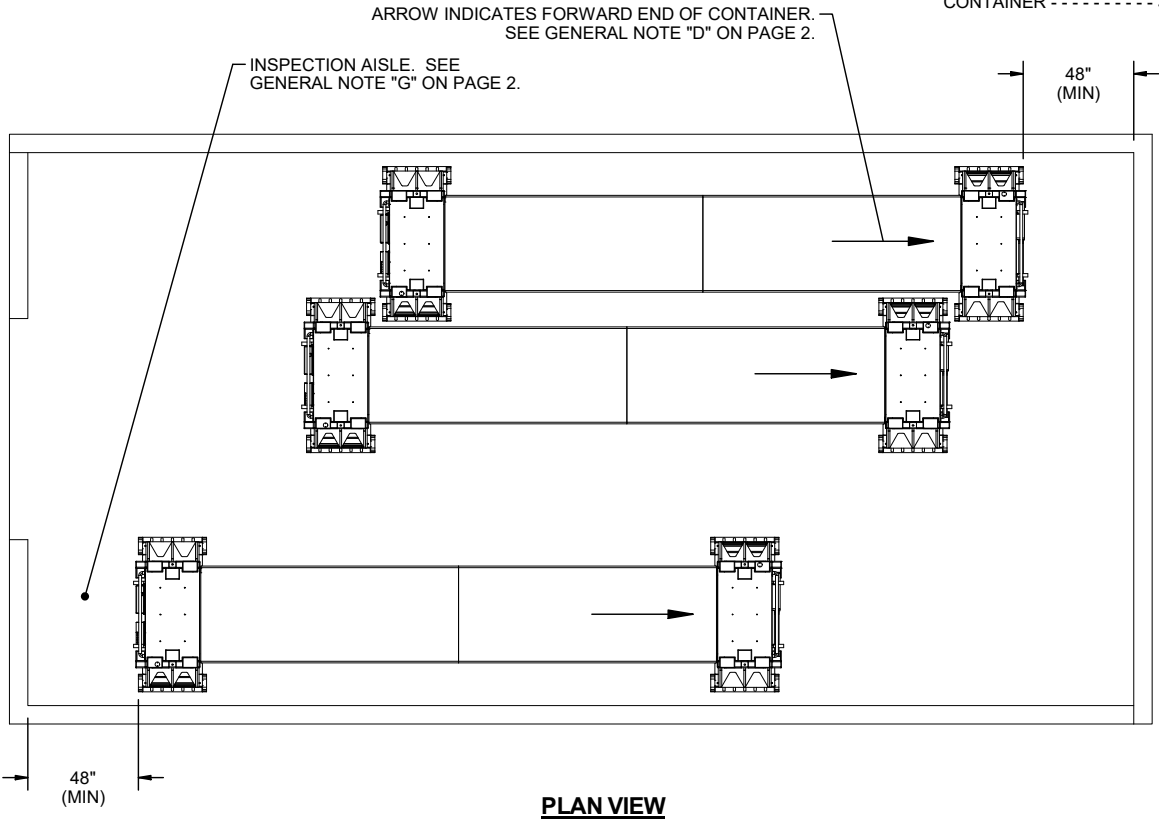

ARROW INDICATES FORWARD END OF CONTAINER.
SEE GENERAL NOTE "D" ON PAGE 2.

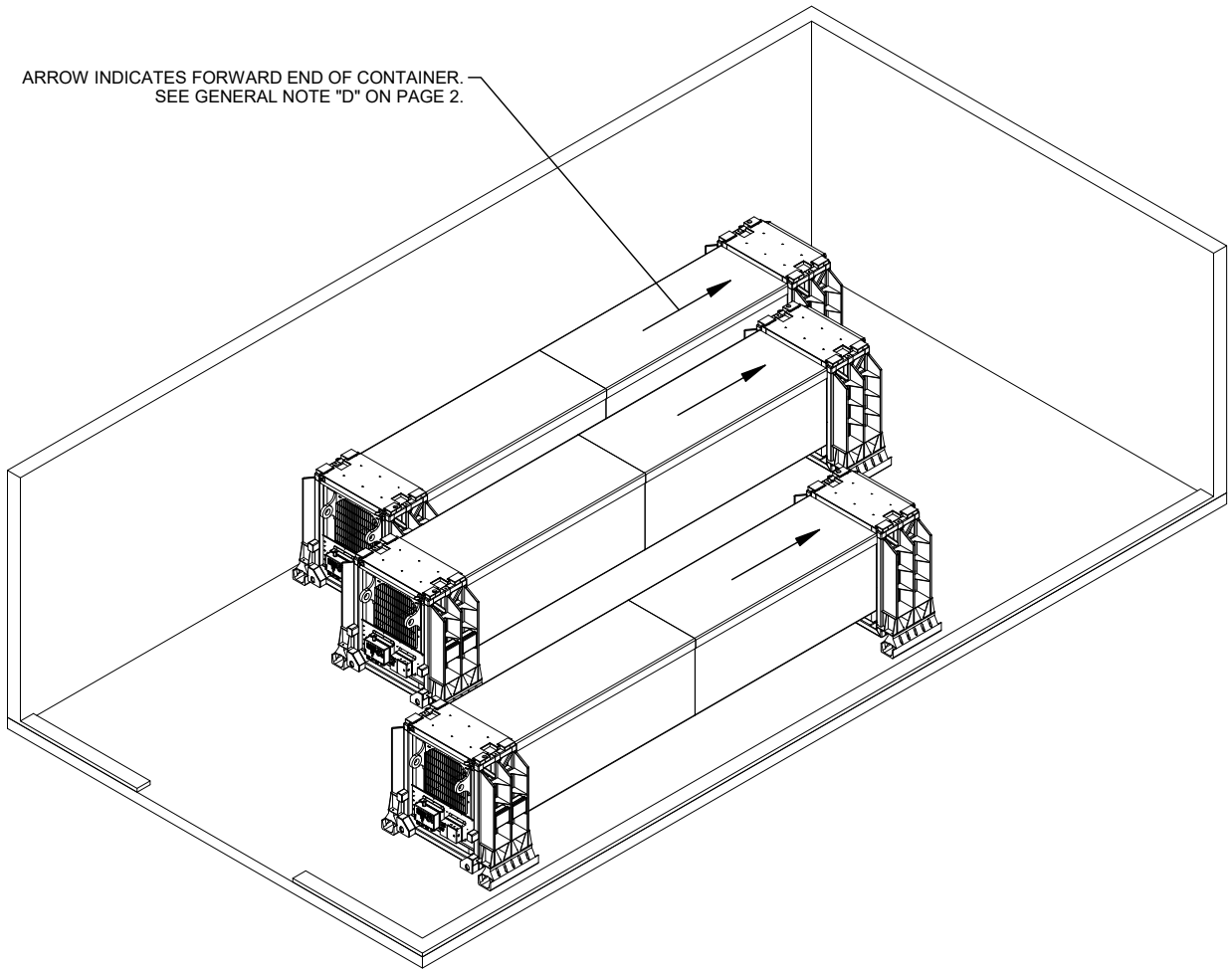

ISOMETRIC VIEW

