



PATRIOT

STORAGE IN APPROVED MAGAZINES OF PATRIOT (PAC-3) PACKED IN SHIPPING AND STORAGE CANISTERS

<u>ITEM</u>	<u>INDEX</u>	<u>PAGE(S)</u>
GENERAL NOTES AND MATERIAL SPECIFICATION	-----	2
CANISTER DETAILS	-----	3
TYPICAL STORAGE IN ARCHED OR ROUNDED ROOF MAGAZINES	-----	4-7
CORBETTA MAGAZINE	-----	8,9
100'-8" L X 50'-0" W RECTANGULAR MAGAZINE	-----	10,11
60'-0" L X 40'-0" W X 15'-0" H TYPE II BUNKER MAGAZINE	-----	12,13
60'-0" L X 40'-0" W X 11'-0" H TYPE III BUNKER MAGAZINE	-----	14,15
40'-0" L X 20'-0" W X 11'-0" H TYPE IV BUNKER MAGAZINE	-----	16,17
DETAILS	-----	18

U.S. ARMY MATERIEL COMMAND DRAWING

APPROVED, U.S. ARMY AVIATION AND MISSILE COMMAND 	CAUTION: VERIFY PRIOR TO USE AT WWW.DAC.ARMY.MIL THAT THIS IS THE MOST CURRENT VERSION OF THIS DOCUMENT. THIS IS PAGE 1 OF 18.			
APPROVED BY ORDER OF COMMANDING GENERAL, U.S. ARMY MATERIEL COMMAND  U.S. ARMY DEFENSE AMMUNITION CENTER	DO NOT SCALE		OCTOBER 2007	
	ENGINEER OR TECHNICIAN	BASIC REV.	MELVIN SIX	
	TRANSPORTATION ENGINEERING DIVISION			
VALIDATION ENGINEERING DIVISION	TESTED	CLASS	DIVISION	DRAWING
ENGINEERING DIRECTORATE	TESTED	19	48	5272
				FILE
				GM1-3-4-14- 22-PA2

GENERAL NOTES

- A. THIS DOCUMENT HAS BEEN PREPARED AND ISSUED IN ACCORDANCE WITH AR 740-1 AND AUGMENTS TM 743-200-1 (CHAPTER 5).
- B. THE STORAGE PROCEDURES DEPICTED WITHIN THIS DOCUMENT ARE APPLICABLE FOR STORAGE IN VARIOUS TYPES AND SIZES OF MAGAZINES. THE STORAGE PROCEDURES DEPICTED FOR THE SPECIFIC TYPES OF MAGAZINES MAY ALSO BE UTILIZED TO STORE PATRIOT ADVANCED CAPABILITY-3 (PAC-3) COMPLETE ROUND IN OTHER TYPES OF APPROVED MAGAZINES. MINOR ADJUSTMENTS MAY BE MADE TO FACILITATE STORAGE IN OTHER TYPES OF MAGAZINES; HOWEVER, THE BASIC PRINCIPLES AS DEPICTED HEREIN WILL BE FOLLOWED.
- C. THE STORAGE PROCEDURES SPECIFIED IN THIS DRAWING ARE APPLICABLE TO PATRIOT ADVANCED CAPABILITY-3 (PAC-3) COMPLETE ROUND, WHEN PACKED IN THE MISSILE CANISTER (SHIPPING, STORAGE AND LAUNCH CANISTER). SEE PAGE 3 AND LOCKHEED-MARTIN DRAWING 13506000 FOR DETAILS OF THE CANISTER.
- D. THIS IS A QD CLASS 1.3 ITEM AND IS IN COMPATIBILITY GROUP C. CAUTION: THIS ITEM IS IN A "PROPULSIVE STATE" AND MUST BE STORED WITH THE FORWARD END FACING TOWARD THE MAGAZINE SIDEWALL OR THE REAR WALL AS INDICATED BY THE DIRECTIONAL ARROWS ON THE STORAGE VIEWS.
- E. CAUTION: THE ALLOWABLE "EXPLOSIVE LIMIT" ESTABLISHED FOR A MAGAZINE IS NOT TO BE EXCEEDED. THIS LIMITATION MAY REQUIRE A QUANTITY REDUCTION FROM THE STORAGE AS SHOWN.
- F. STORED CANISTERS MUST NOT CONTACT THE SIDES OF A MAGAZINE. THEREFORE, CANISTERS MUST BE STORED A MINIMUM OF 6" FROM THE SIDEWALL OR CURVATURE OF THE MAGAZINE AS APPLICABLE. TO PROVIDE FOR THIS MANDATORY CLEARANCE REQUIREMENT, CANISTERS MAY BE ELIMINATED FROM THE DEPICTED STORAGE PATTERN AS NECESSARY.
- G. MHE AISLE DIMENSION SHOWN FOR STORAGE PROCEDURES IN MAGAZINES MAY BE ADJUSTED TO SUIT LOCAL CONDITIONS, VARIATIONS IN CANISTER DIMENSIONS, AND/OR AVAILABLE MATERIAL HANDLING EQUIPMENT (MHE).
- H. THE MAXIMUM FLOOR LOAD FOR A MAGAZINE AS PRESCRIBED WILL NOT BE EXCEEDED.
- J. IF AVAILABLE MHE PERMITS, ADDITIONAL CANISTERS MAY BE STORED WITHIN THE MHE AREA OF THE MAGAZINE.
- K. THE HEIGHT OF THE PACKAGE GUARD ON SOME FORKLIFT TRUCKS MAY NOT PERMIT PLACEMENT OF SOME TOP LAYER CANISTERS IN THE STACKS SHOWN IN THE STORAGE VIEWS HEREIN; UNLESS TWO UPPER CANISTERS ARE HANDLED AS ONE LIFT OR THE PACKAGE GUARD IS REMOVED (TINE CARRIAGE WILL IN MOST INSTANCES PROVIDE ADEQUATE PACKAGE GUARD PROTECTION). ONLY A FORKLIFT TRUCK OF ADEQUATE CAPACITY WILL BE USED WHEN LIFTING TWO CANISTERS AS ONE LIFT. NOTE: CANISTERS MAY NOT BE STACKED MORE THAN FOUR CANISTERS HIGH.
- L. THE USE OF "SUPPORT" IS REQUIRED FOR ALL CANISTERS STACKED TWO MORE LAYERS HIGH. SEE THE "TYPICAL FLOOR DUNNAGE DETAIL" ON PAGE 18 FOR A TYPICAL INSTALLATION.

(CONTINUED AT RIGHT)

(GENERAL NOTES CONTINUED)

- M. THE STORAGE PROCEDURES ON PAGES 10 AND 16 ARE BASED ON MAXIMUM SPACE UTILIZATION OF THE MAGAZINES. HOWEVER, END-HANDLING OF CANISTER STACKS WILL BE REQUIRED FOR FINAL POSITIONING IN EITHER ALL OF THE ROWS OR SOME OF THE ROWS AT ONE SIDE OF THE MAGAZINE. THE HEIGHT OF CANISTER STACKS TO BE END-HANDLED WILL BE DEPENDENT UPON THE MHE AND THE HANDLING CAPACITIES OF THE INSTALLATION INVOLVED AND MAY THEREFORE, REDUCE THE QUANTITY OF CANISTERS THAT CAN BE STORED IN A MAGAZINE.
- N. TO PREVENT DAMAGE TO THE CANISTER, FORK TINES MAY NOT BE PLACED UNDER THE AFT END OF THE CANISTER.
- O. WHEN LOCAL STORAGE CONDITIONS ARE SUCH THAT AN AMMUNITION STORAGE MAGAZINE NET EXPLOSIVE WEIGHT LIMIT WILL BE REACHED BEFORE ALL AVAILABLE STORAGE SPACE WILL BE UTILIZED, A COMBINATION OF THE VARIOUS STORAGE PATTERNS DELINEATED HEREIN MAY BE USED IN LIEU OF BLOCK STORAGE PATTERNS TO FACILITATE INVENTORY, INSPECTION, THE USE OF MATERIAL HANDLING EQUIPMENT, SURVEILLANCE, ETC., OF THE AMMUNITION TO BE STORED WITHIN THE MAGAZINE.
- P. CANISTERS PRESENTLY STORED IN ACCORDANCE WITH A PRIOR APPROVED DRAWING NEED NOT BE RE-STORED SOLELY TO CONFORM TO THE PROCEDURES SPECIFIED IN THIS DOCUMENT.
- Q. OTHER COMPATIBLE ITEMS MAY BE STORED IN A MAGAZINE, WHICH IS PARTIALLY FILLED WITH THE DESIGNATED ITEM.
- R. PORTIONS OF THE MAGAZINES, SUCH AS SIDEWALLS, ENDWALLS, AND ROOFS HAVE NOT BEEN SHOWN IN THE STORAGE VIEWS FOR CLARITY PURPOSES.
- S. THE USE OF NOMINAL SIZE 1" X 4" X 41" OR 2" X 4" X 41" FLOOR DUNNAGE UNDER EACH END OF EACH FIRST-LAYER CANISTER IS OPTIONAL, ALTHOUGH THE USE OF THIS TYPE OF DUNNAGE IS DELINEATED WITHIN THIS STORAGE PROCEDURE DRAWING. THE PURPOSE OF FLOOR DUNNAGE IS TO HELP KEEP THE RUNNERS OF A CANISTER DRY, THUS AIDING IN PREVENTING DETERIORATION DUE TO CORROSION. THEREFORE, FLOOR DUNNAGE SHOULD BE USED WHEN STORING IN A MAGAZINE THAT IS KNOWN TO HAVE A "DAMP" FLOOR. IN GLOO, ARCH TYPE AND STRADLEY MAGAZINES WHICH HAVE FLOORS SLOPING TOWARD THE SIDEWALLS, THE DEPICTED STORAGE PATTERNS INCLUDE CANISTER STACKS WHICH STRADDLE THE RIDGE OF THE FLOOR AT THE CENTER OF THE MAGAZINE. IT MAY BE NECESSARY, THEREFORE, TO USE 2" THICK MATERIAL FOR FLOOR DUNNAGE UNDER THESE STACKS TO PREVENT THE BOTTOM OF THE CANISTERS FROM CONTACTING THE CONCRETE FLOOR. TO ACHIEVE SOUND AND ACCEPTABLE STABLE STACKS FROM THE FLOOR TO THE TOP OF THE STACK, STACK STABILIZING DUNNAGE IN THE FORM OF VARIOUS THICKNESSES OF FLOOR DUNNAGE WILL BE USED IF REQUIRED. FLOOR DUNNAGE WILL BE USED AS REQUIRED UNDER THE LOAD BEARING LOCATIONS AT THE ENDS OF FIRST-LAYER CANISTERS AND THE "SUPPORT" UNDER THE STACK FRAME. SEE THE "TYPICAL FLOOR DUNNAGE DETAIL" ON PAGE 18 FOR A TYPICAL INSTALLATION.
- T. DUNNAGE LUMBER SPECIFIED THROUGHOUT THIS PROCEDURAL DRAWING IS OF NOMINAL SIZE. FOR EXAMPLE, 1" X 4" MATERIAL IS ACTUALLY 3/4" THICK BY 3-1/2" WIDE AND 2" X 6" MATERIAL IS ACTUALLY 1-1/2" THICK BY 5-1/2" WIDE.
- U. CONVERSION TO METRIC EQUIVALENTS: DIMENSIONS WITHIN THIS DOCUMENT ARE EXPRESSED IN INCHES, AND WEIGHTS ARE EXPRESSED IN POUNDS. WHEN NECESSARY, THE METRIC EQUIVALENT MAY BE COMPUTED ON THE BASIS OF ONE INCH EQUALS 25.4MM, AND ONE POUND EQUALS 0.454 KG.

MATERIAL SPECIFICATION

LUMBER -----: SEE TM 743-200-1 (DUNNAGE LUMBER) AND VOLUNTARY PRODUCT STANDARD PS 20.

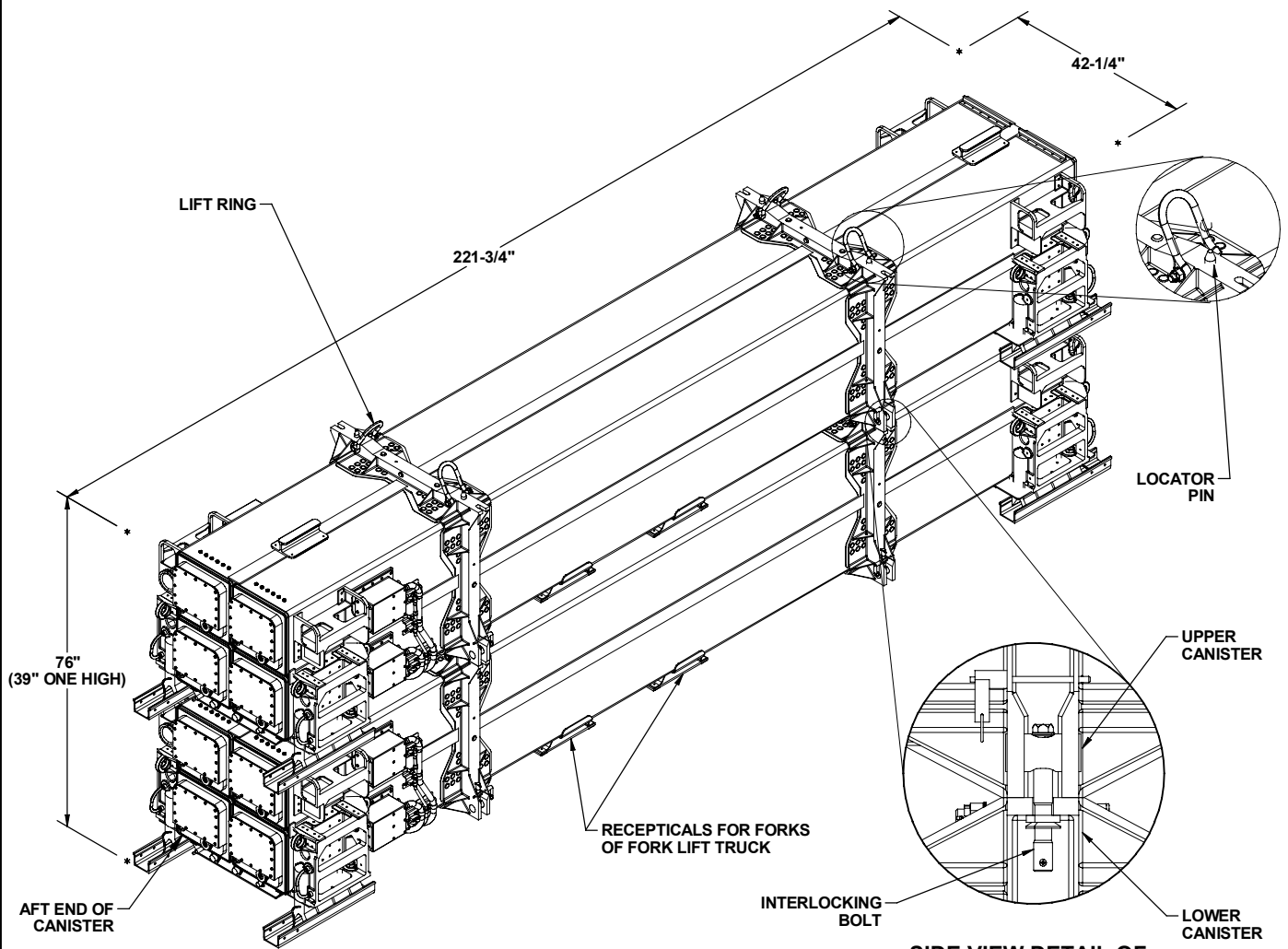

TYPICAL STACK DETAIL

SIDE VIEW DETAIL OF INTERLOCKING BOLT ASSEMBLY

PATRIOT PAC-3 DETAIL

GROSS WEIGHT - - - - - 4,399 LBS (APPROX)
 CUBE - - - - - 209.2 CU FT (APPROX)

UNITIZATION AND HANDLING PROCEDURAL GUIDANCE

(PROCEDURAL GUIDANCE CONTINUED)

1. STACKING CANISTER FOR UNITIZATION.
 - A. THE SKIDS OF THE UPPER CANISTER MUST BE FULLY SEATED UPON THE LOCATOR PINS OF THE LOWER CANISTER.
 - B. POSITION THE FORWARD END OF THE UPPER CANISTER ABOVE THE FORWARD END OF THE LOWER CANISTER.
 - C. CANISTER INTERLOCKING BOLTS MUST BE TIGHTENED AS SECURELY AS POSSIBLE WITH A NORMAL HAND TOOL WRENCH (REF: 60 FOOT POUNDS).

- A. ONLY APPROVED AND APPROPRIATELY SIZED MATERIAL HANDLING EQUIPMENT WILL BE USED FOR HANDLING THE DEPICTED CANISTERS.
- B. IF HANDLING IS ACCOMPLISHED WITH A FORK TRUCK, THE CANISTERS SHOULD BE HANDLED FROM A SIDE POSITION AS MUCH AS POSSIBLE. CARE MUST BE EXERCISED WHEN INSERTING FORKS UNDER A CANISTER, TO PREVENT DAMAGE TO THE CANISTER BY THE FORK TINES OR THE FORKLIFT PACKAGE GUARD. FOR VERY SHORT "INCHING" SPEED MOVEMENTS, SUCH AS WILL BE EXPERIENCED DURING CONTAINER LOADING, A TWO-HIGH CANISTER STACK MAY BE HANDLED BY INSERTING THE FORKS OF THE FORKLIFT TRUCK INTO THE FORK RECEPTACLES OF THE UPPER CANISTER.

2. CANISTER OR CANISTER STACK HANDLING.

NOTES: (1) APPROVED MATERIAL HANDLING EQUIPMENT (MHE) IS SPECIFIED IN OTHER DOCUMENTS. MHE IS INTENDED TO MEAN EQUIPMENT SUCH AS FORKLIFT TRUCKS, CRANES, HAND TRUCKS, DOLLIES, ROLLER ASSEMBLIES, SLINGS, AND SPREADER BARS.

- C. SLINGING OF A CANISTER OR A CANISTER STACK WILL BE IN ACCORDANCE WITH APPROVED PROCEDURES.

(2) PRECAUTIONARY HANDLING TECHNIQUES NORMALLY EMPLOYED OR AS SPECIFIED FOR THE TYPE OF COMMODITY INVOLVED WILL BE OBSERVED.

(CONTINUED AT RIGHT)

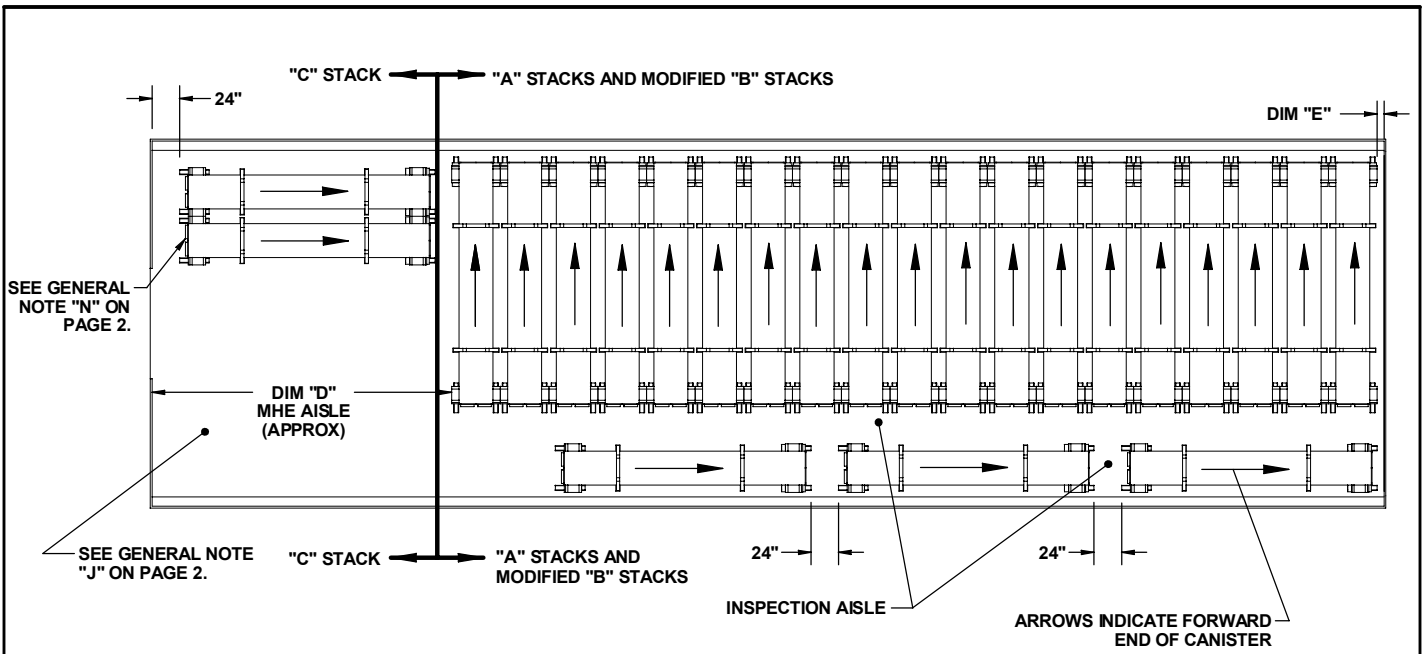

PLAN VIEW

NOTE: FOR IDENTIFICATION OF LETTERED DIMENSIONS REFER TO CHART 1 ON PAGE 6.

STACK COLUMN DESIGNATIONS

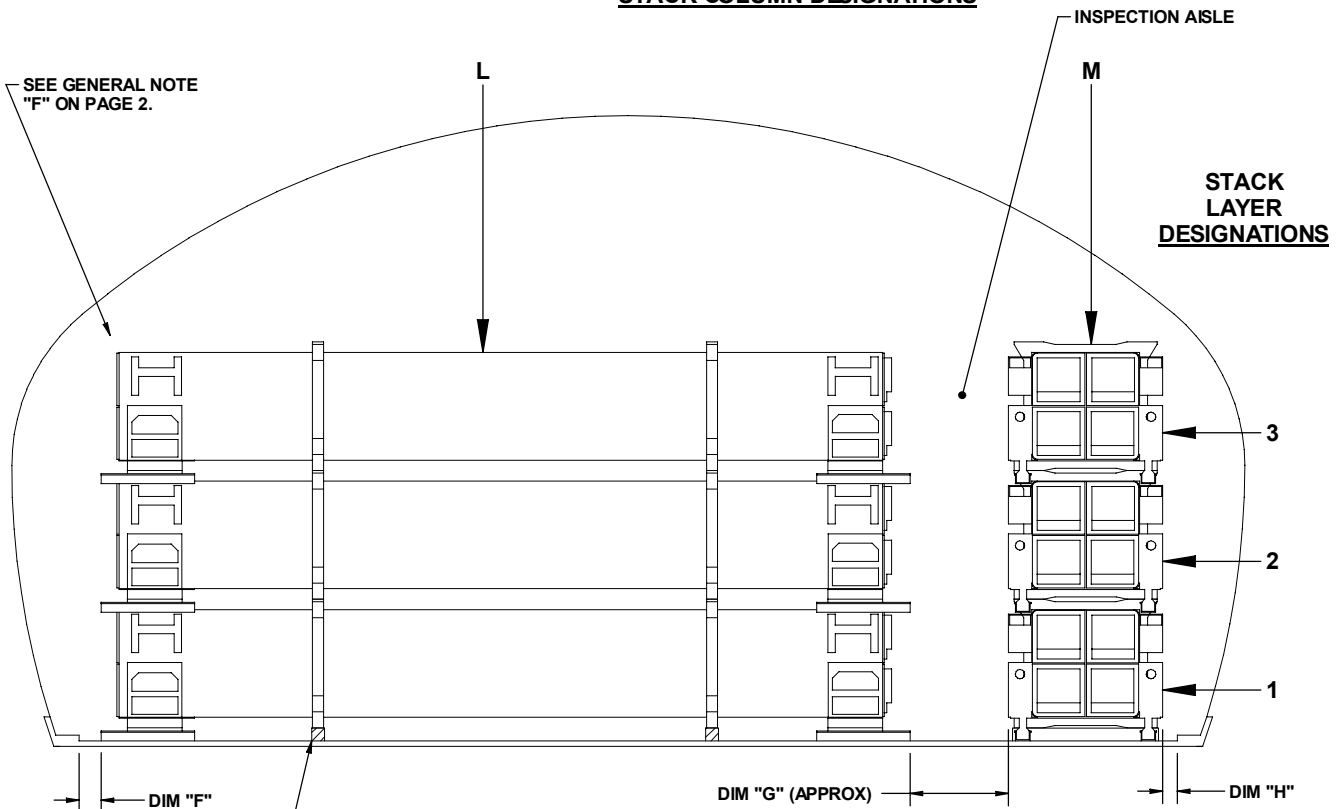

SUPPORT, 4" X 4" X 41" (2 REQD PER FIRST LAYER UNIT). SEE GENERAL NOTE "L" ON PAGE 2.

"A" STACKS AND MODIFIED "B" STACKS

(SEE "STACK IDENTIFICATION" ON PAGE 18 AND "CHART 2 - STACK CONFIGURATION" ON PAGE 7.)

TYPICAL STORAGE IN ARCHED OR ROUNDED ROOF MAGAZINES

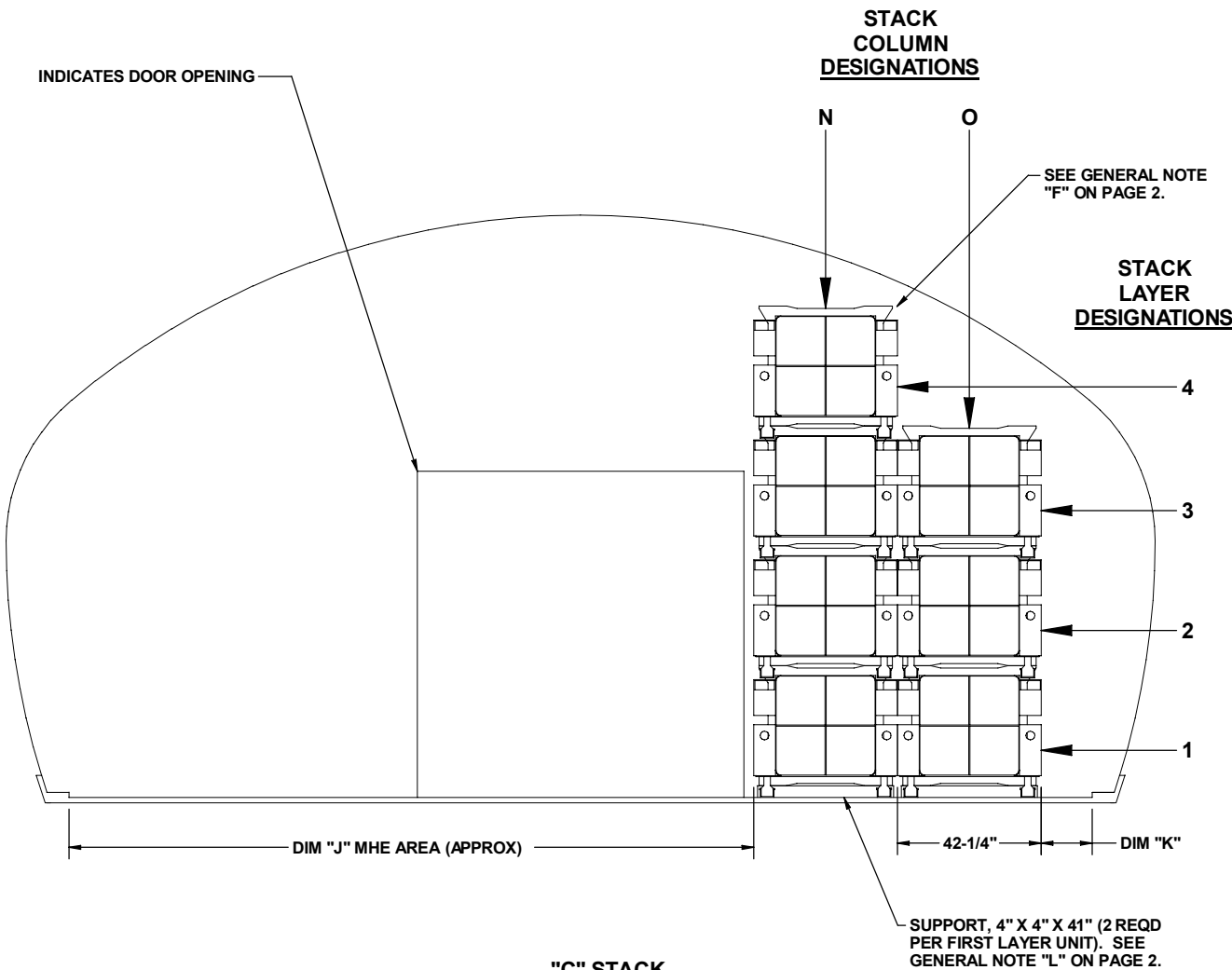

NOTE: FOR IDENTIFICATION OF LETTERED DIMENSIONS REFER TO CHART 1 ON PAGE 6.

"C" STACK

TYPICAL "C" STACK FOR OVAL MAGAZINE.
(SEE "STACK IDENTIFICATION " ON PAGE 18 AND "CHART 2 - STACK CONFIGURATION" ON PAGE 7)

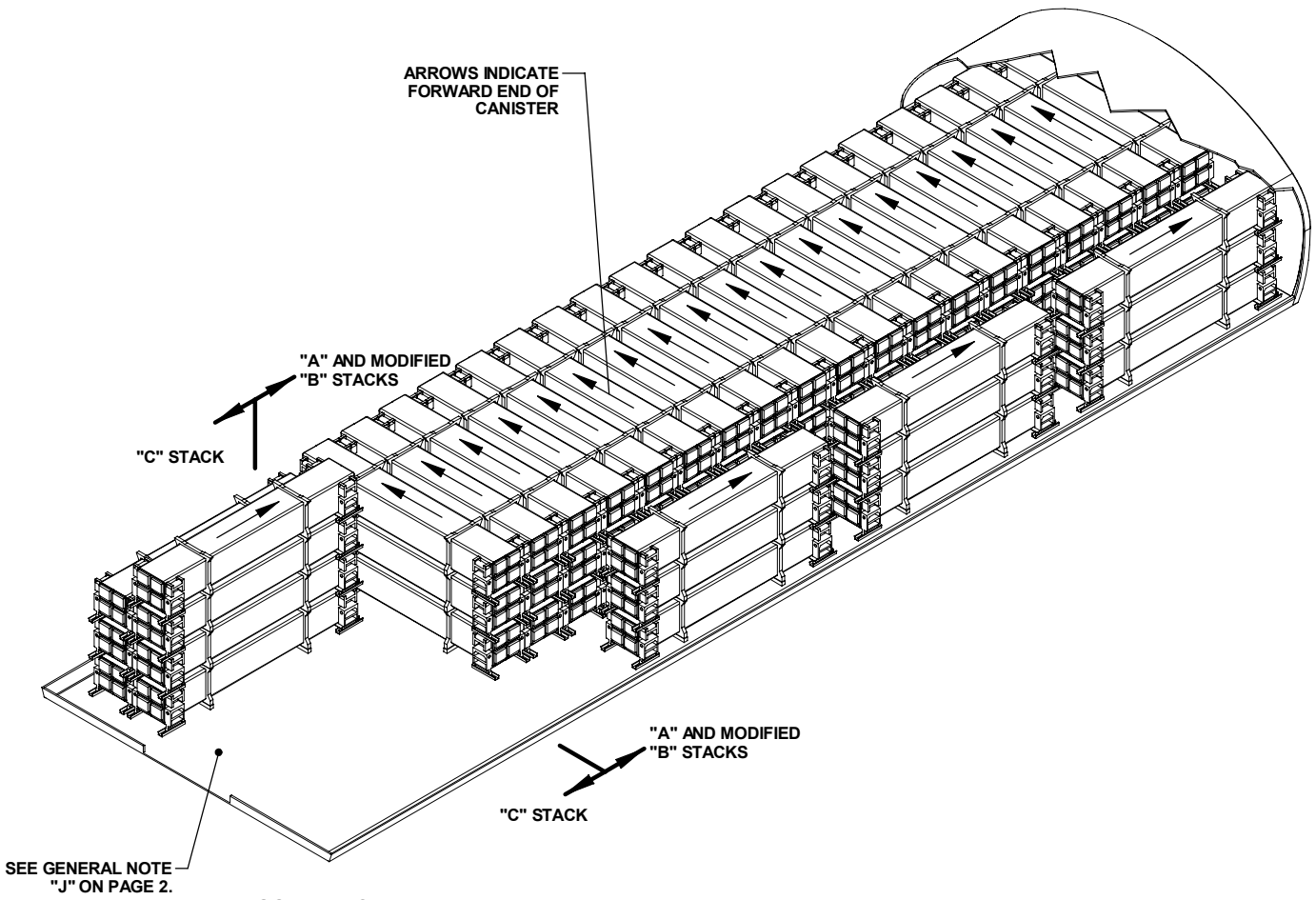

ISOMETRIC VIEW

OVAL MAGAZINE SHOWN AS TYPICAL

BILL OF MATERIAL (PER STACK)*		
LUMBER	LINEAR FEET	BOARD FEET
4" X 4"	7	10

* BILL OF MATERIAL ONLY REFLECTS SUPPORT DUNNAGE. IF FLOOR DUNNAGE IS UTILIZED, BILL OF MATERIAL WILL INCREASE. SEE GENERAL NOTES "L" AND "S" ON PAGE 2.

CHART 1 - DIMENSIONS

MAGAZINE DIMENSIONS	MAGAZINE TYPE													
	IGLOO			ARCH 12'		ARCH 11'		ARCH 10'		OV AL ARCH	STRADLEY	STEEL ARCH		
	40'-4"	60'-8"	81'-0"	26'-6"	25'-0"	40'-0"	80'-0"	40'-0"	80'-0"	89'-0"	80'-0"	59'-0"	89'-0"	
LENGTH	40'-4"	60'-8"	81'-0"	81'-2"	40'-0"	80'-0"	40'-0"	80'-0"	40'-0"	80'-0"	89'-0"	80'-0"	59'-0"	89'-0"
WIDTH	26'-6"			26'-6"	25'-0"	25'-0"	25'-0"	25'-0"	25'-0"	24'-10"	25'-0"	25'-0"	24'-11"	
HEIGHT	12'-9"			12'-1-3/4"		11'-0"		10'-0"		14'-5"	14'-0"	14'-0"	13'-6"	
DIMENSIONS	CANISTER SPACING DIMENSIONS													
DIM "D" (M HE AISLE APPROX)	22'-0"	21'-6"	20'-9"	22'-11"	21'-2"	22'-5"	21'-2"	22'-5"	21'-10"	23'-1"	21'-8"	23'-1"	23'-4"	21'-8"
DIM "E" ("A" & "B" STACK BACK)	6"	6"	6"	14"	14"	14"	14"	14"	6"	6"	6"	6"	6"	6"
DIM "F" ("A" STACK SIDE)	19"	19"	19"	24"	34"	34"	28"	28"	12"	12"	6"	8"	30"	30"
DIM "G" ("A" TO "B" STACK OR "A" STACK SIDE) (APPROX)	68"	68"	68"	67"	35"	35"	45-1/2"	45-1/2"	61"	61"	27"	70"	48"	48"
DIM "H" ("B" STACK SIDE)	--	--	--	--	--	--	--	--	--	--	4"	--	--	--
DIM "J" M HE AREA (APPROX)	11'-1"	11'-1"	11'-1"	13'-6"	10'-5"	10'-5"	9'-2"	9'-2"	9'-4"	9'-5"	12'-11"	12'-11"	13'-5"	9'-8"
DIM "K" ("C" STACK SIDE)	7"	7"	7"	14"	9"	9"	12"	16"	17-3/4"	17"	15"	12"	6"	8"

TYPICAL STORAGE IN ARCHED OR ROUNDED ROOF MAGAZINES

CHART 2 - STACK CONFIGURATION

MAGAZINE TYPE

QUANTITY PER MAGAZINE	IGLOO			ARCH 12'	ARCH 12' X 25' W		ARCH 11'		ARCH 10'		OVAL ARCH	STRADLEY	STEEL ARCH	
	40'-4" L	60'-8" L	81'-0" L	26'-6" W	40'-0" L	80'-0" L	40'-0" L	80'-0" L	40'-0" L	80'-0" L			59'-0" L	89'-0" L
	13	25	37	37	13	35	13	35	8	19	66	55	32	61

"A" STACK CONFIGURATION

LAYER	CANISTERS PER LAYER													
1	1(L)			1(L)	1(L)		1(L)		1(L)		1(L)	1(L)	1(L)	
2	1(L)			1(L)	1(L)		1(L)		--		1(L)	1(L)	1(L)	
3	--			--	--		--		--		1(L)	1(L)	1(L)	
SINGLE STACK TOTAL	2			2	2		2		1		3	3	3	
NUMBER OF STACKS	5	11	17	27	5	16	5	16	5	16	19	16	10	19
"A" STACK TOTAL	10	22	34	34	10	32	10	32	5	16	57	48	30	57

MODIFIED "B" STACK CONFIGURATION

LAYER	CANISTERS PER LAYER													
1	--			--	--		--		--		1(M)	--	--	
2	--			--	--		--		--		1(M)	--	--	
3	--			--	--		--		--		1(M)	--	--	
SINGLE STACK TOTAL	--			--	--		--		--		3	--	--	
NUMBER OF STACKS	--			--	--		--		--		3	--	--	
"B" STACK TOTAL	0			0	0		0		0		9	0	0	

"C" STACK CONFIGURATION

LAYER	CANISTERS PER LAYER														
1	2(N-O)			2(N-O)		2(N-O)		2(N-O)		2(N-O)		2(N-O)	2(N-O)	2(N-O)	
2	1(O)			1(O)		1(O)		1(O)		1(O)		2(N-O)	2(N-O)	1(N)	
3	--			--		--		--		--		2(N-O)	2(N-O)	1(N)	
4	--			--		--		--		--		1(N)	1(N)	--	
NUMBER OF STACKS	1			1		1		1		1		1	1	1	
"C" STACK TOTAL	3			3		3		3		3		7	7	4	

SPECIAL NOTES:

- THE FOLLOWING NOTES, CHART 1 ON PAGE 6 AND CHART 2 ON THIS PAGE ARE PRESENTED AS GUIDANCE IN THE SELECTION OF A STORAGE PATTERN, AND IN DETERMINING THE QUANTITY OF CANISTERS WHICH CAN BE STORED IN THE STORAGE MAGAZINES LISTED IN THESE CHARTS.
- CHART 1 ON PAGE 6 DESCRIBES THE STORAGE MAGAZINE GENERAL DIMENSIONS AND THE DIMENSIONS OF THE CANISTER SPACING WITHIN THE STORAGE MAGAZINES.
- DIMENSIONS "A", "B" AND "C" HAVE BEEN OMITTED TO AVOID CONFUSION WITH STACKS "A", "B" AND "C".
- CHART 2 ON THIS PAGE DETAILS THE QUANTITY OF CANISTERS IN EACH TYPE OF MAGAZINE AND THE LAYOUT OF THE STACKS FOR EACH TYPE OF MAGAZINE. THE CHART SHOWS THE NUMBER OF CANISTERS IN EACH STACK LAYER AND THE LOCATION OF THE CANISTER ON EACH LAYER.

(CONTINUED AT RIGHT)

EXAMPLE:

CHART 2 - "A" STACK CONFIGURATION
MAGAZINE: OVAL

LAYER NUMBER 1: 1 (L)
LAYER NUMBER 2: 1 (L)
LAYER NUMBER 3: 1 (L)

EXPLANATION:

LAYER 1 (BOTTOM LAYER) HAS ONE CANISTER IN THE "L" COLUMN.
LAYER 2 (ON TOP OF LAYER 1) HAS ONE CANISTER IN THE "L" COLUMN.
LAYER 3 (ON TOP OF LAYER 2) HAS ONE CANISTER IN THE "L" COLUMN.

STORAGE IN 44'-7" MAGAZINE

STORAGE IN 52'-0" MAGAZINE

ITEM QUANTITY
 CANISTER ----- 34

ITEM QUANTITY
 CANISTER ----- 49

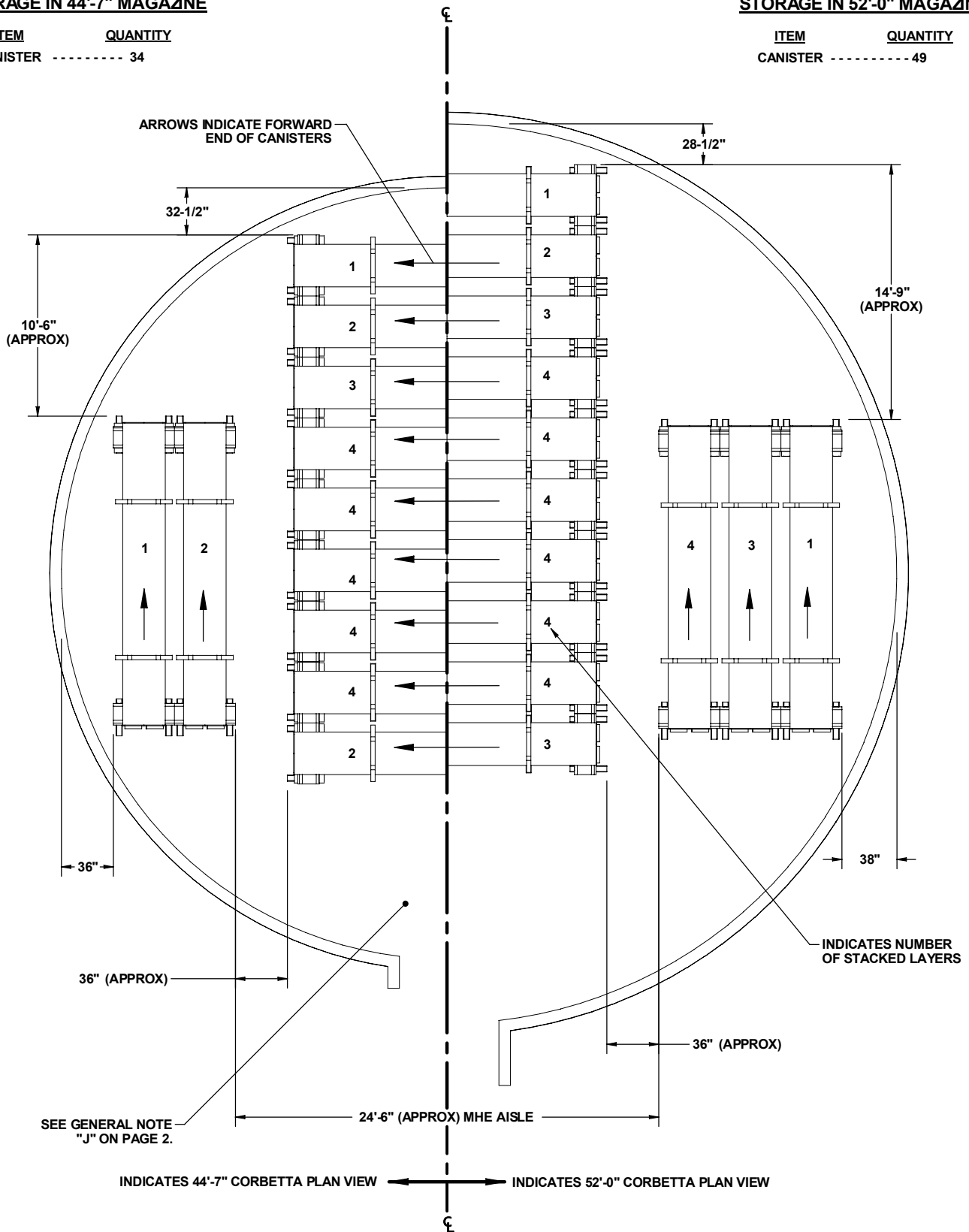

PLANVIEW

THE RIGHT HAND PLAN VIEW INDICATES A 52'-0" CORBETTA MAGAZINE, AND THE LEFT HAND PLAN VIEW INDICATES A 44'-7" CORBETTA MAGAZINE. BOTH SIZE MAGAZINE LAYOUTS ARE SYMMETRICAL AROUND THE VERTICAL CENTER LINE.

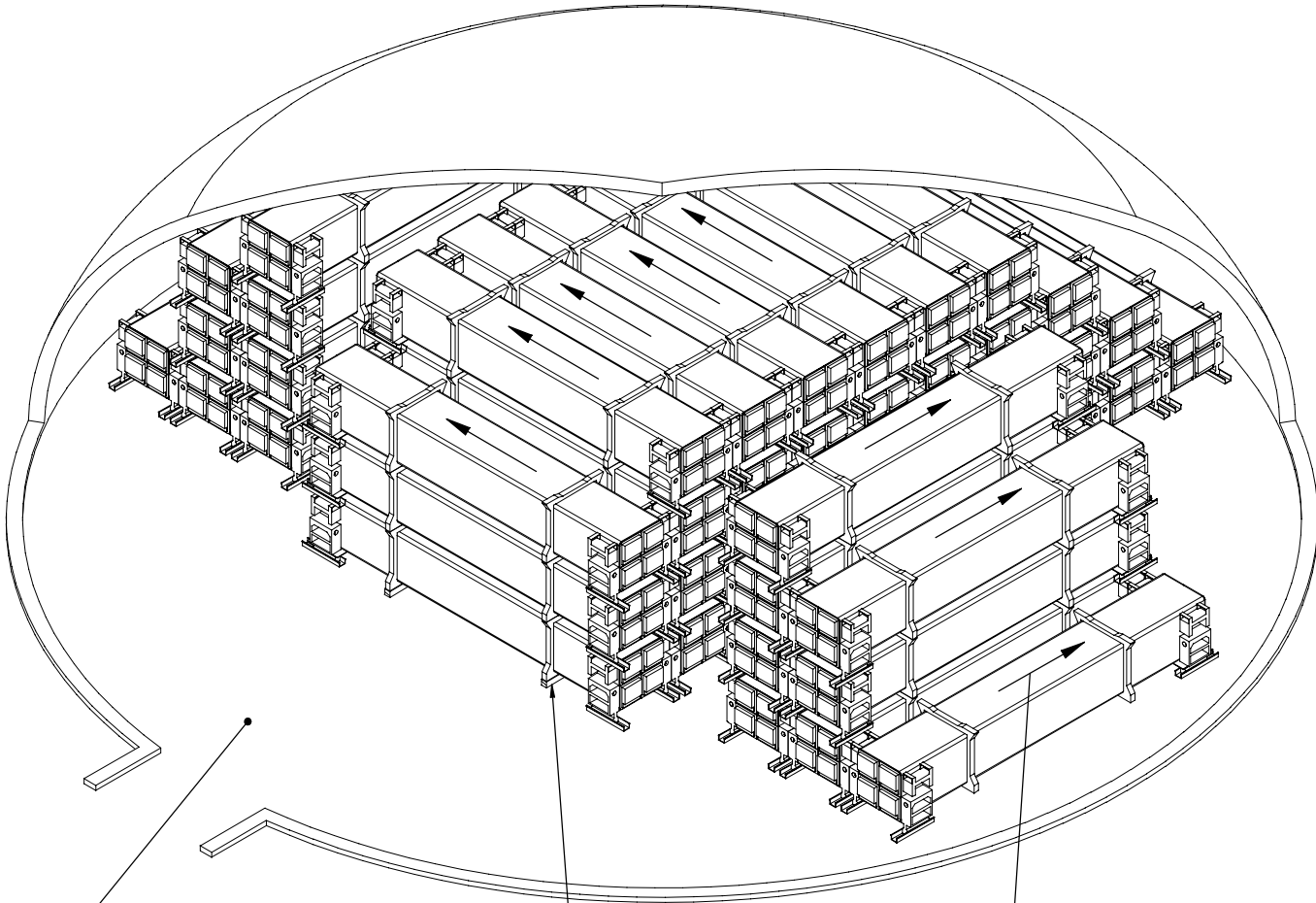

SEE GENERAL NOTE "J" ON PAGE 2.

SUPPORT, 4" X 4" X 41" (2 REQD PER FIRST LAYER UNIT). SEE GENERAL NOTE "L" ON PAGE 2.

ARROWS INDICATE FORWARD END OF CANISTER

ISOMETRIC VIEW
(52' - 0" DIA MAGAZINE)

BILL OF MATERIAL (PER STACK)*		
LUMBER	LINEAR FEET	BOARD FEET
4" X 4"	7	10

* BILL OF MATERIAL ONLY REFLECTS SUPPORT DUNNAGE. IF FLOOR DUNNAGE IS UTILIZED, BILL OF MATERIAL WILL INCREASE. SEE GENERAL NOTES "L" AND "S" ON PAGE 2.

**STORAGE IN RECTANGULAR
MAGAZINE**

ITEM	QUANTITY
CANISTERS	----- 176

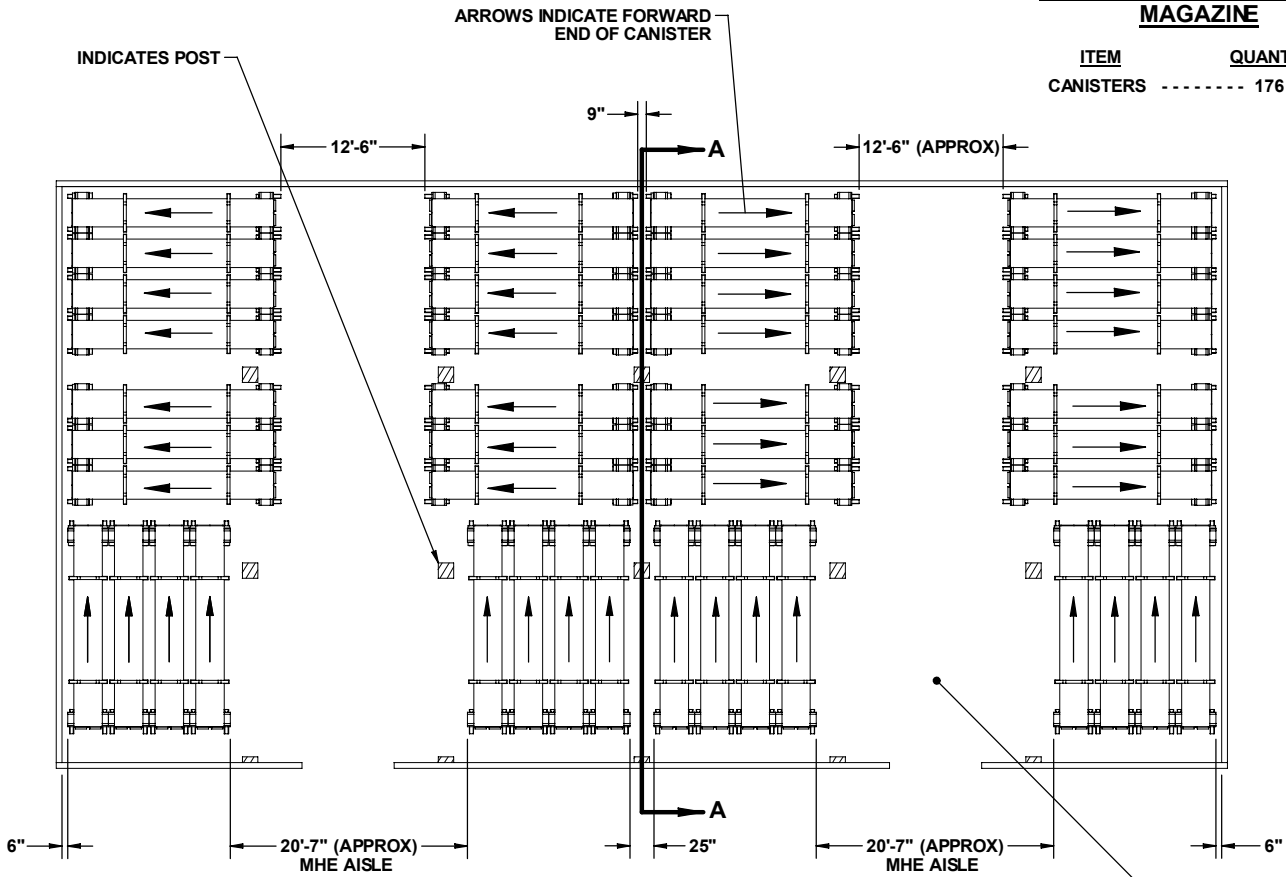

PLAN VIEW

ALL CANISTERS ARE STACKED
FOUR LAYERS HIGH.

SEE GENERAL
NOTE "J" ON
PAGE 2.

SEE GENERAL NOTE
"F" ON PAGE 2.

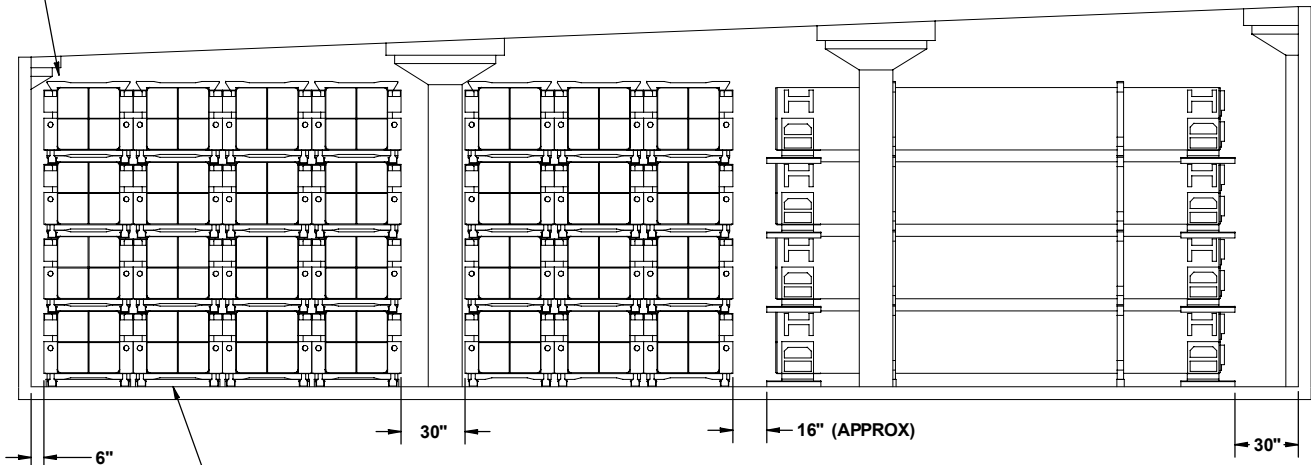

SECTION A-A

SUPPORT, 4" X 4" X 41" (2 REQD
PER FIRST LAYER UNIT). SEE
GENERAL NOTE "L" ON PAGE 2.

ARROWS INDICATE FORWARD
END OF CANISTER

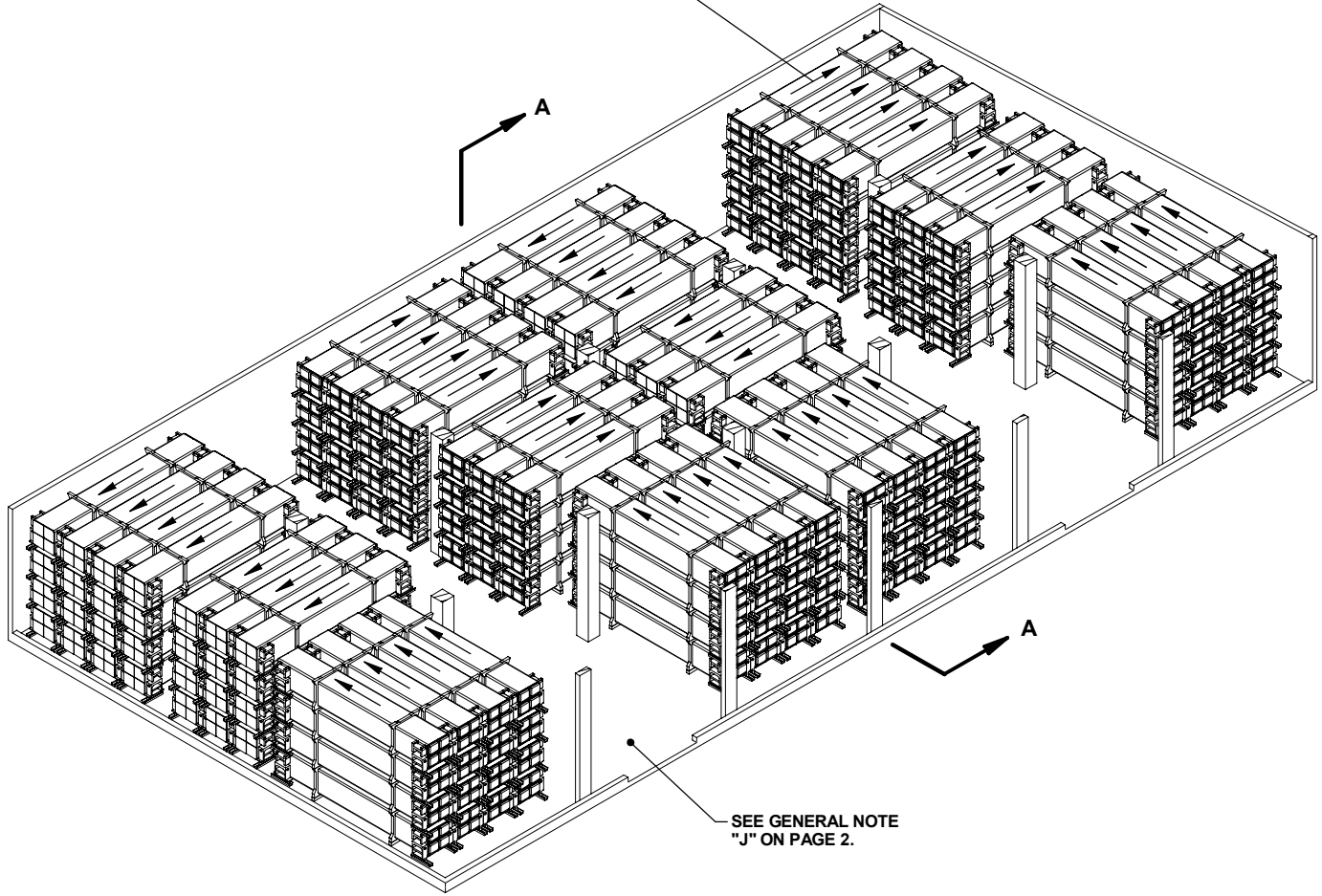

ISOMETRIC VIEW

(50'-0" MAGAZINE)

BILL OF MATERIAL (PER STACK)*		
LUMBER	LINEAR FEET	BOARD FEET
4" X 4"	7	10

* BILL OF MATERIAL ONLY REFLECTS SUPPORT DUNNAGE. IF FLOOR DUNNAGE IS UTILIZED, BILL OF MATERIAL WILL INCREASE. SEE GENERAL NOTES "L" AND "S" ON PAGE 2.

**STORAGE IN TYPE II BUNKER
MAGAZINE**

ITEM QUANTITY
CANISTER ----- 108

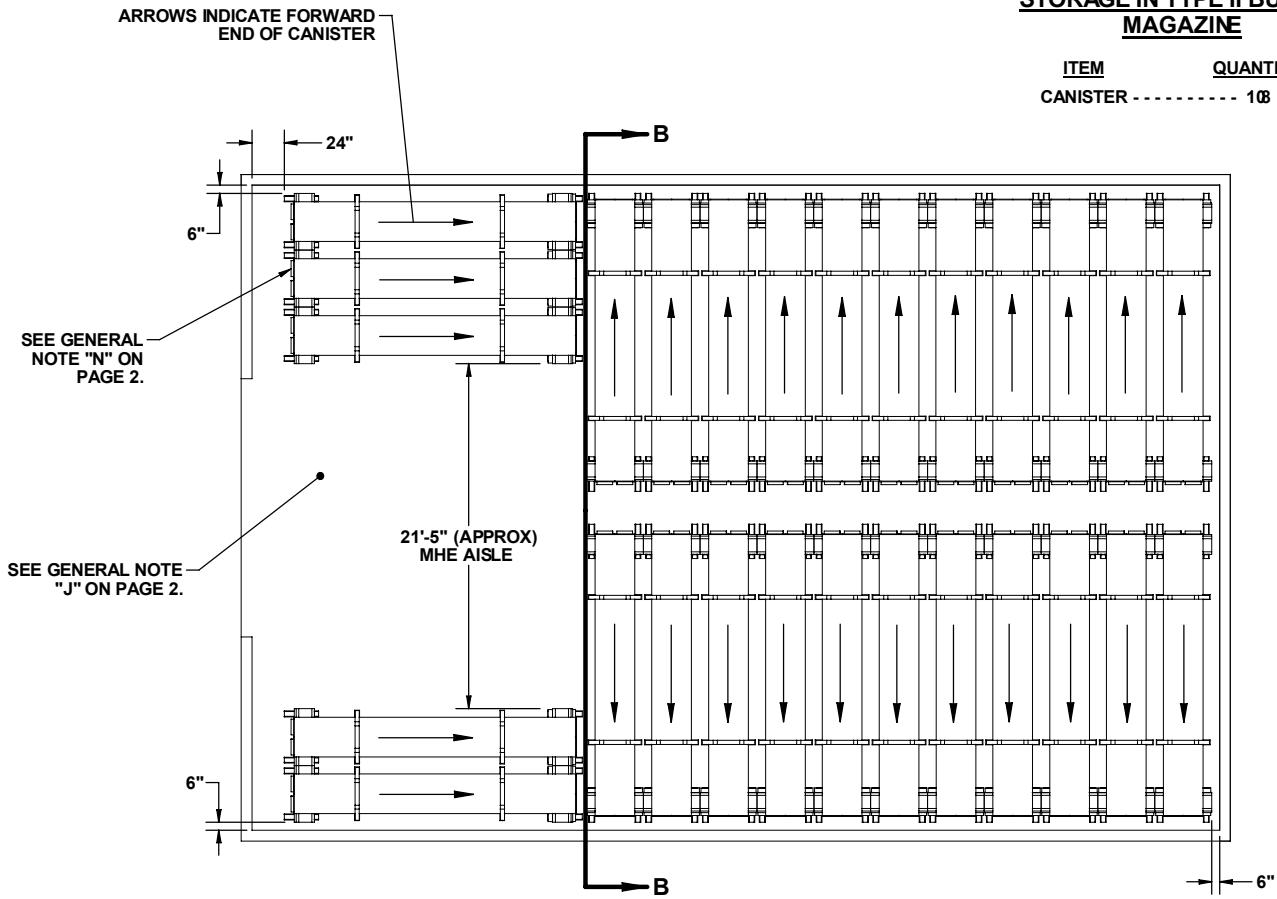

PLAN VIEW

ALL CANISTERS ARE STACKED FOUR LAYERS HIGH.

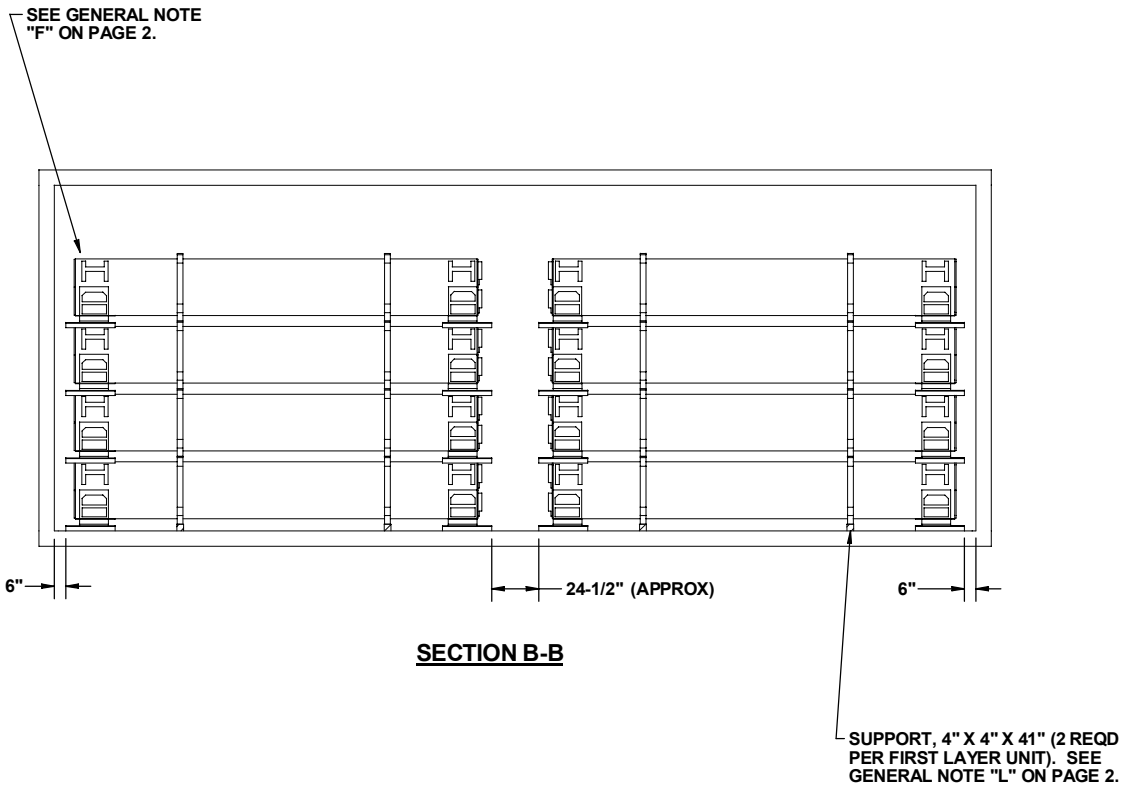

ARROWS INDICATE FORWARD
END OF CANISTER

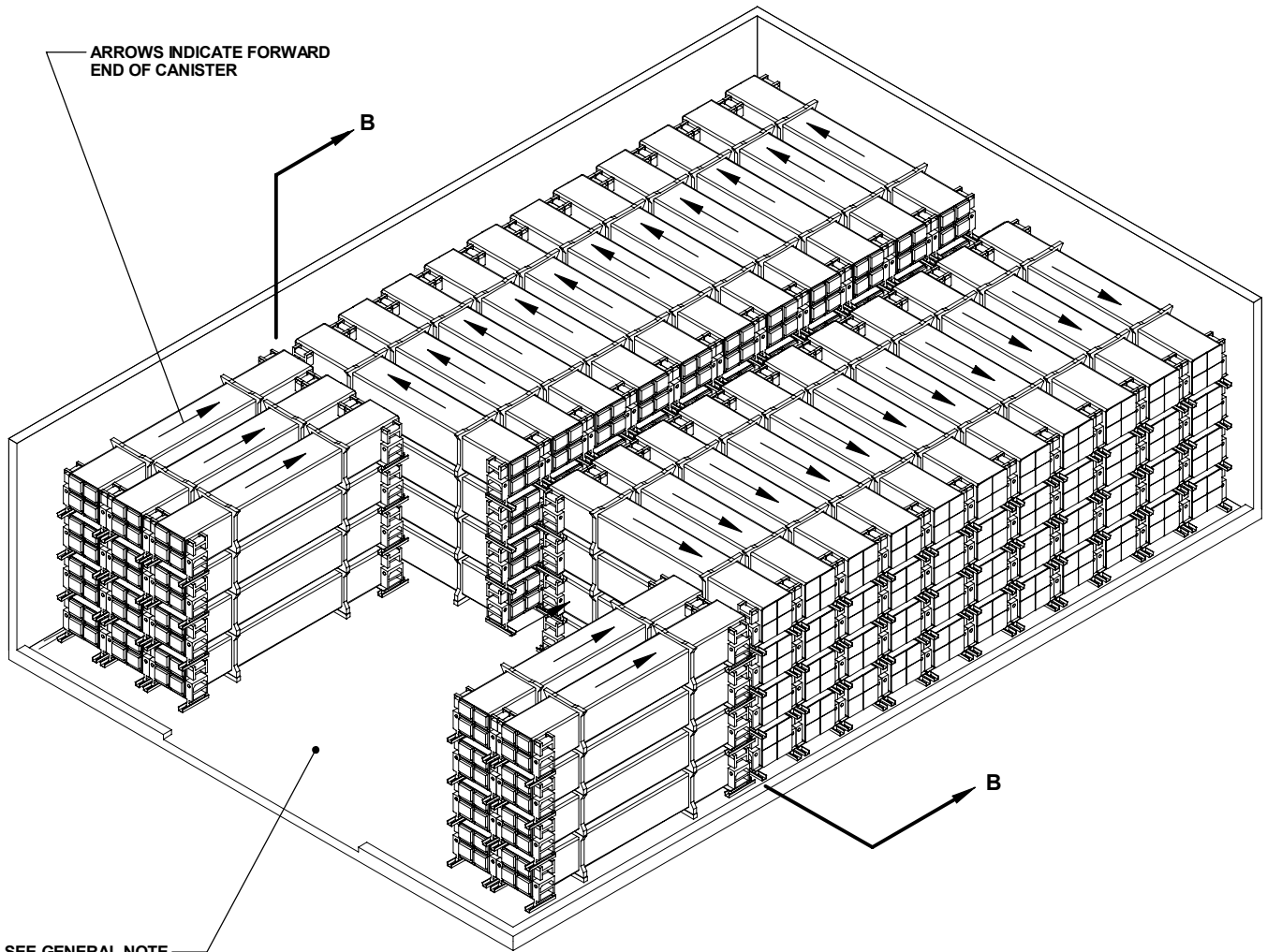

SEE GENERAL NOTE
"J" ON PAGE 2.

ISOMETRIC VIEW

(TYPE II BUNKER MAGAZINE)

BILL OF MATERIAL (PER STACK)*		
LUMBER	LINEAR FEET	BOARD FEET
4" X 4"	7	10

* BILL OF MATERIAL ONLY REFLECTS SUPPORT DUNNAGE. IF FLOOR DUNNAGE IS UTILIZED, BILL OF MATERIAL WILL INCREASE. SEE GENERAL NOTES "L" AND "S" ON PAGE 2.

60'-0" L X 40'-0" W X 15'-0" H TYPE II BUNKER MAGAZNE

**STORAGE IN TYPE III BUNKER
MAGAZINE**

ITEM	QUANTITY
CANISTERS	----- 63

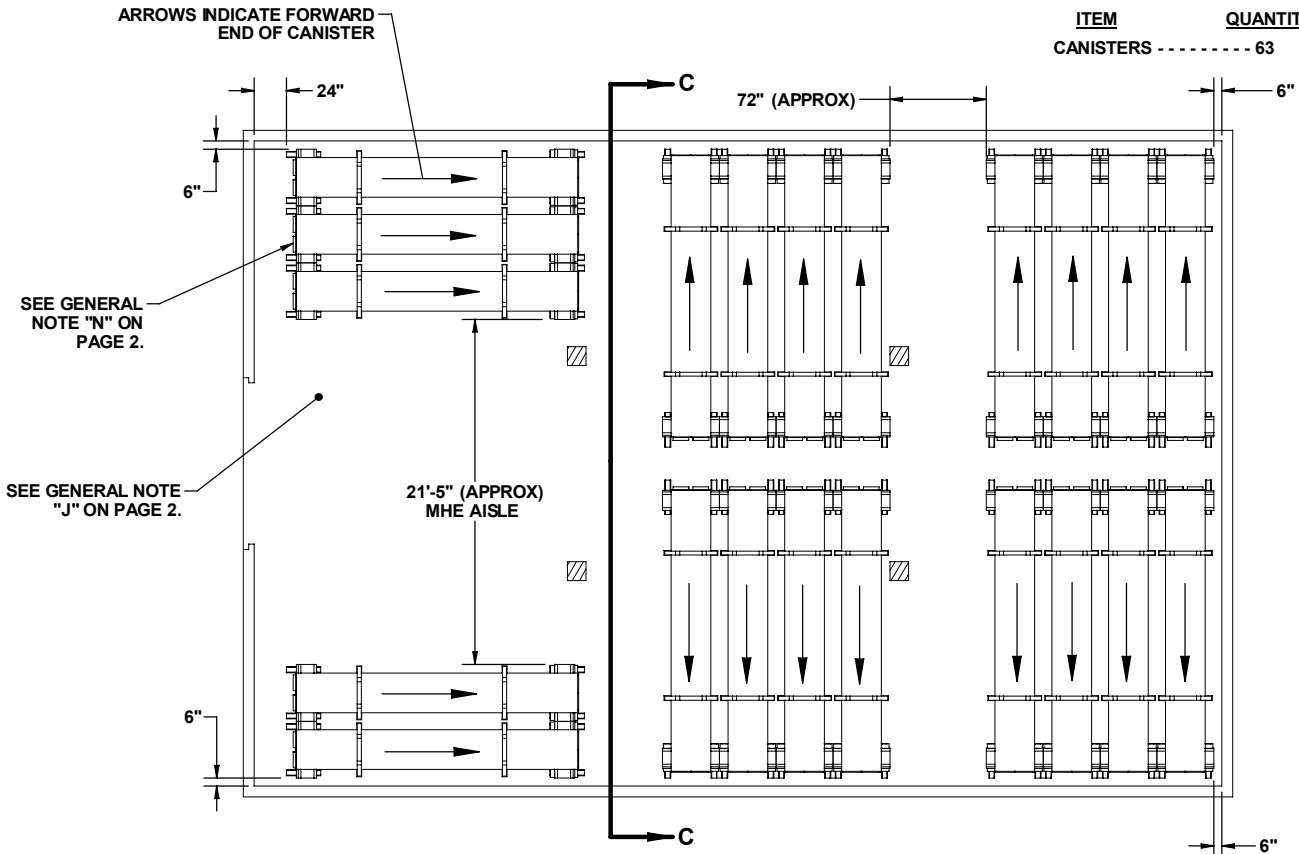

PLAN VIEW

ALL CANISTERS ARE STACKED THREE LAYERS HIGH.

SEE GENERAL NOTE "F" ON PAGE 2.

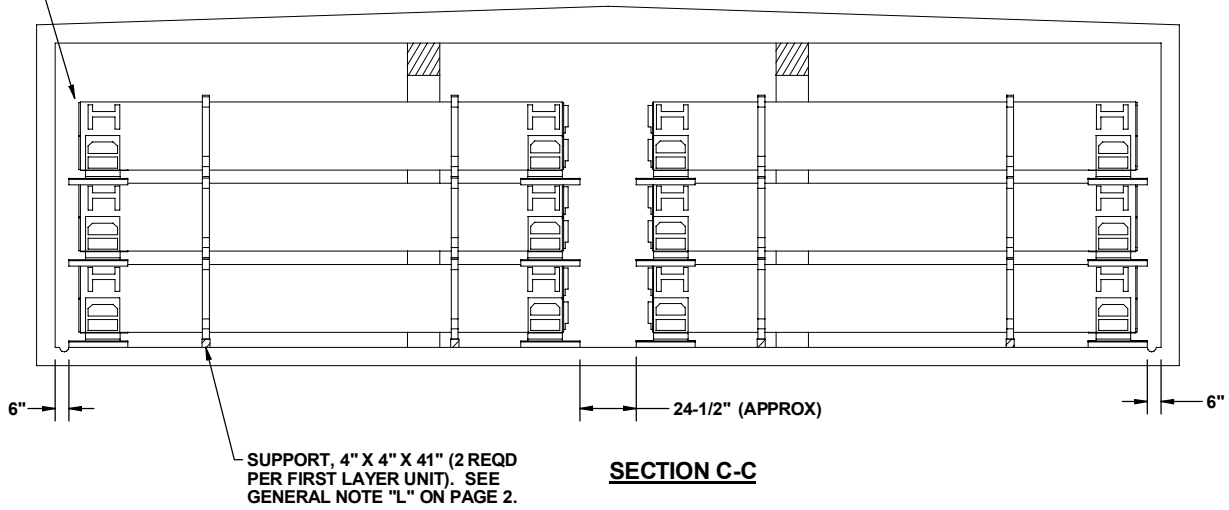

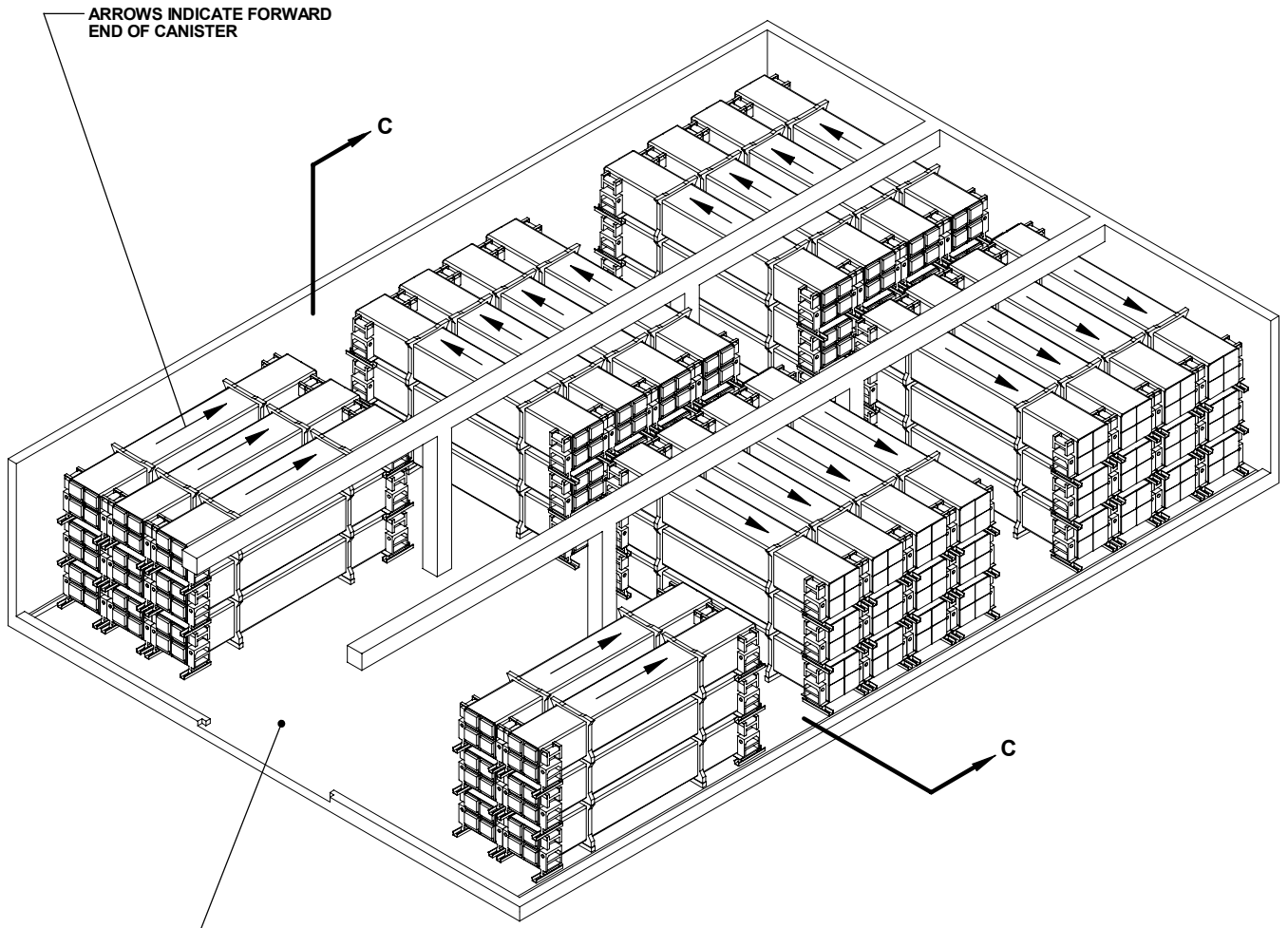

SEE GENERAL NOTE
"J" ON PAGE 2.

ISOMETRIC VIEW
(TYPE III BUNKER MAGAZINE)

BILL OF MATERIAL (PER STACK)*		
LUMBER	LINEAR FEET	BOARD FEET
4" X 4"	7	10

* BILL OF MATERIAL ONLY REFLECTS SUPPORT DUNNAGE. IF FLOOR DUNNAGE IS UTILIZED, BILL OF MATERIAL WILL INCREASE. SEE GENERAL NOTES "L" AND "S" ON PAGE 2.

60'-0" L X 40'-0" W X 11'-0" H TYPE III BUNKER MAGAZINE

**STORAGE IN TYPE IV BUNKER
MAGAZINE**

ITEM	QUANTITY
CANISTER - - - - -	15

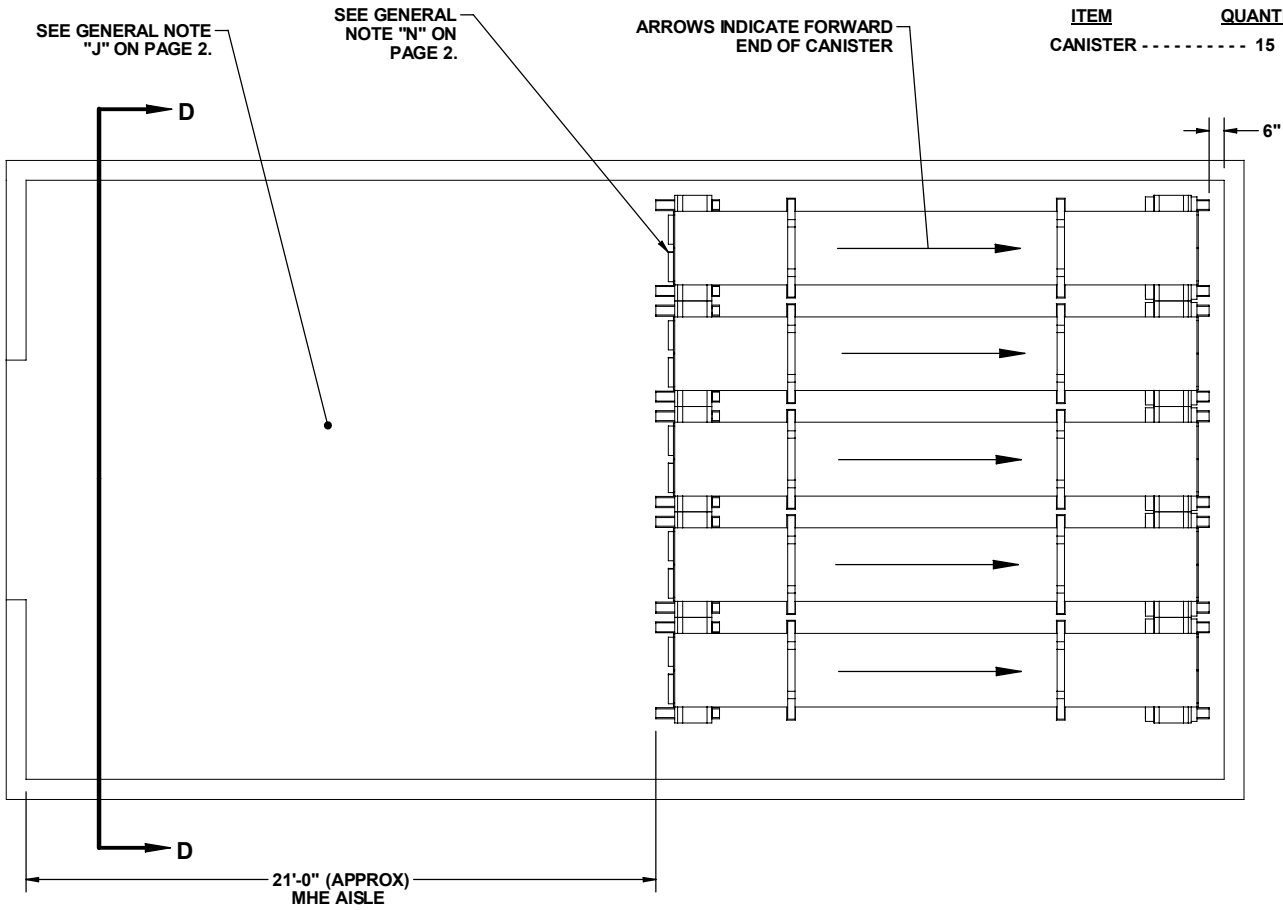

PLAN VIEW

ALL CANISTERS ARE STACKED THREE LAYERS HIGH.

SEE GENERAL NOTE "F" ON PAGE 2.

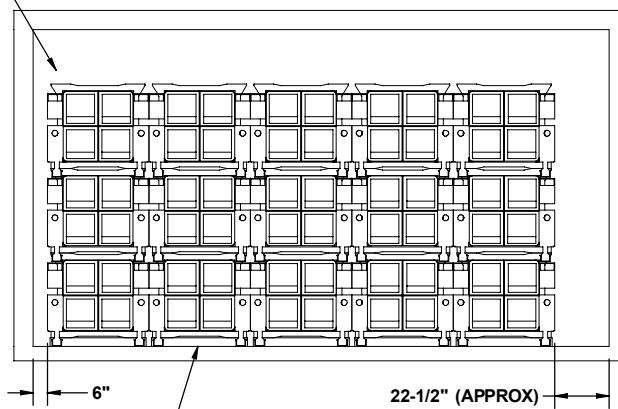

SECTION D-D

SUPPORT, 4" X 4" X 41" (2 REQD PER FIRST LAYER UNIT). SEE GENERAL NOTE "L" ON PAGE 2.

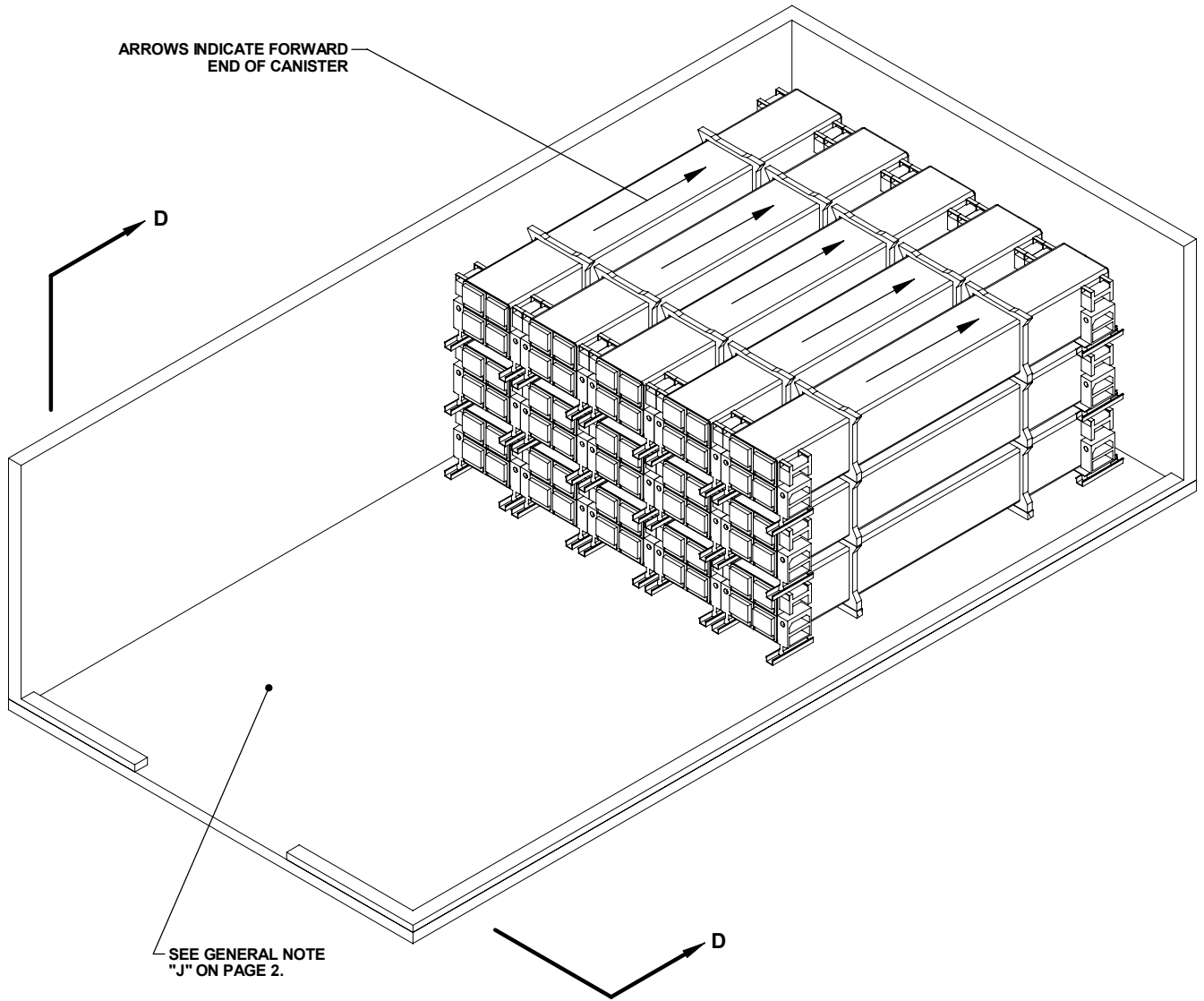

ISOMETRIC VIEW
(TYPE IV BUNKER MAGAZINE)

BILL OF MATERIAL (PER STACK)*		
LUMBER	LINEAR FEET	BOARD FEET
4" X 4"	7	10

* BILL OF MATERIAL ONLY REFLECTS SUPPORT DUNNAGE. IF FLOOR DUNNAGE IS UTILIZED, BILL OF MATERIAL WILL INCREASE. SEE GENERAL NOTES "L" AND "S" ON PAGE 2.

40'-0" L X 20'-0" W X 11'-0" H TYPE IV BUNKER MAGAZINE

STACK IDENTIFICATION

A TYPE "A" STACK IS IDENTIFIED AS A GROUP OF ITEMS /UNITS WHICH EXTENDS FULL WIDTH AND HEIGHT OF THE MAGAZINE, AND IS ONE ITEM/UNIT LONG IN THE LENGTH OF THE MAGAZINE.

A TYPE "B" STACK IS IDENTIFIED AS A GROUP OF ITEMS/UNITS WHICH EXTEND FULL WIDTH AND HEIGHT OF THE MAGAZINE, AND IS ONE UNIT/ITEM LONG, BUT HAS AN AISLE AT OR NEAR THE CENTER OF THE WIDTH OF THE STACK.

A TYPE "C" STACK IS IDENTIFIED AS A GROUP OF ITEMS/UNITS WHICH IS ONE UNIT/ITEM LONG AND CONSISTS OF PARTIAL STACKS ON EACH SIDE OF THE MAGAZINE, USUALLY ONE ITEM/UNIT HIGH ON ONE SIDE OF THE MAGAZINE.

NOTE: A MODIFIED "B" STACK IS IDENTIFIED AS A GROUP OF ITEMS/UNITS THAT ARE ON ONE SIDE OF THE TYPE "A" STACK AND ARE ORIENTED WITH THE LENGTH OF THE ITEMS/UNITS ALONG THE LENGTH OF THE STORAGE MAGAZINE.

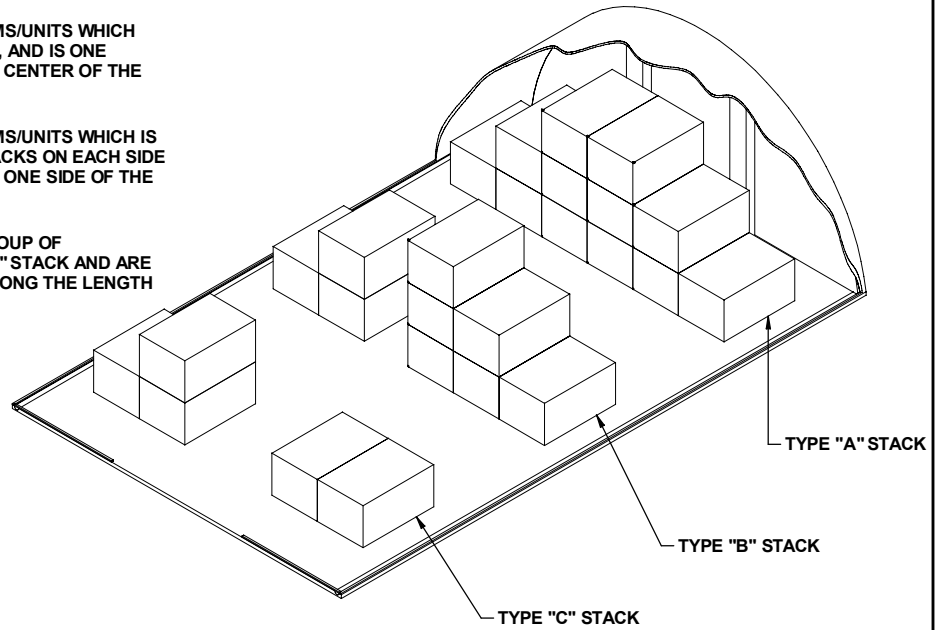

MAGAZINE FLOOR

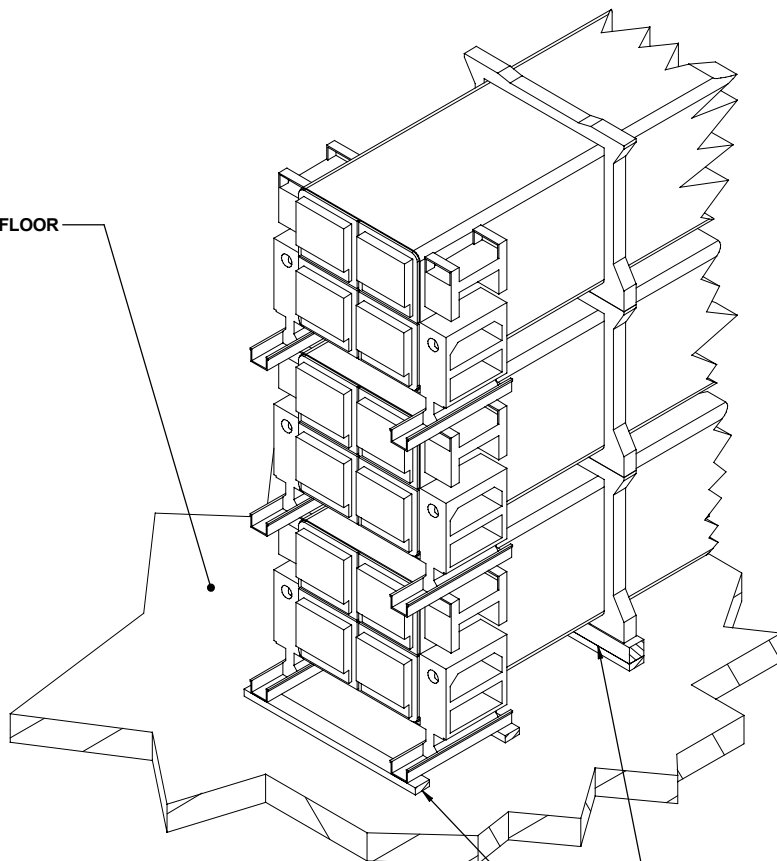

SUPPORT, 4" X 4" X 41" (2 REQD PER FIRST LAYER UNIT). SEE GENERAL NOTE "L" ON PAGE 2.

FLOOR DUNNAGE, 1" X 4" X 41" OR 2" X 4" X 41" (6 SHOWN PER FIRST-LAYER CANISTER). POSITION TWO UNDER THE SKIDS AT EACH END OF THE CANISTER AND ONE UNDER EACH SUPPORT. SEE GENERAL NOTE "S" ON PAGE 2.