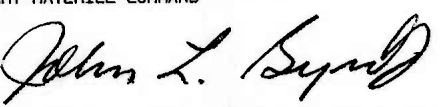
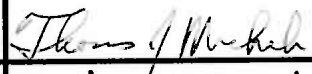
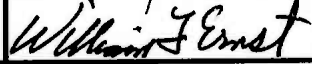

MLRS

STORAGE IN APPROVED MAGAZINES OF ROCKET POD/CONTAINERS (RP/C) FOR THE MULTIPLE LAUNCH ROCKET SYSTEM

INDEX

<u>ITEM</u>	<u>PAGE(S)</u>
GENERAL NOTES AND MATERIAL SPECIFICATIONS - - - - -	2
DETAILS - - - - -	3
STORAGE PROCEDURES (EARTH COVERED MAGAZINES):	
81'-0", 60'-8" AND 40'-4" L X 26'-6" W X 12'-9" H IGLOO MAGAZINES - - - -	4-7
80'-0" AND 40'-0" L X 25'-0" W X 10'-0" H ARCH TYPE MAGAZINES (IGLOO) - -	8,9
80'-0" AND 40'-0" L X 25'-0" W X 11'-0" H ARCH TYPE MAGAZINES (IGLOO) - -	10,11
80'-0" AND 40'-0" L X 25'-0" W X 12'-1-3/4" H ARCH TYPE MAGAZINES (IGLOO)	12,13
81'-2" L X 26'-6" W X 12'-1-3/4" H ARCH TYPE MAGAZINE (IGLOO) - - - -	14,15
80'-0" L X 25'-0" W X 14'-0" H STRADLEY AND 89'-0" L X 24'-10" W X 14'-4" H OVAL-ARCH MAGAZINES - - - - -	16,17
52'-0" DIAMETER CORBETTA MAGAZINE - - - - -	18,19
100'-8" L X 50'-0" W RECTANGULAR MAGAZINE - - - - -	20,21
60'-0" L X 40'-0" W X 15'-0" H TYPE II BUNKER MAGAZINE - - - - -	22,23
60'-0" L X 40'-0" W X 11'-0" H TYPE III BUNKER MAGAZINE - - - - -	24,27
40'-0" L X 20'-0" W X 11'-0" H TYPR IV BUNKER MAGAZINE - - - - -	28,29
GUIDANCE FOR STORAGE OF ROCKET PODS WITH RISER AND SPACER ASSEMBLIES ATTACHED - - - - -	30,31

U. S. ARMY MATERIEL COMMAND DRAWING			
APPROVED, U. S. ARMY MISSILE COMMAND  AMSMI-LC-MM-DP	DRAFTSMAN	D. WHITMORE	
APPROVED BY ORDER OF COMMANDING GENERAL, U. S. ARMY MATERIEL COMMAND  U. S. ARMY DEFENSE AMMUNITION CENTER AND SCHOOL	ENGINEER	M. DAEUMER	
	SUPPLY ENGINEERING DIVISION		
U. S. ARMY DEFENSE AMMUNITION CENTER AND SCHOOL	LOGISTICS ENGINEERING OFFICE		
	SEPTEMBER 1989		
REVISION NO. 4	OCTOBER 1992	CLASS	DIVISION
SEE THE REVISION LISTING ON PAGE 3		DRAWING	FILE
		19	48
		5245	GM 1-3-4- 14-22RS1

DO NOT SCALE

GENERAL NOTES

- A. THIS DOCUMENT HAS BEEN PREPARED AND ISSUED IN ACCORDANCE WITH AR 740-1 AND AUGMENTS TM 743-200-1 (CHAPTER 5).
- B. THE STORAGE PROCEDURES SPECIFIED IN THIS DRAWING ARE APPLICABLE TO THE MULTIPLE LAUNCH ROCKET SYSTEM (MLRS) COMPLETE ROUND WHEN PACKED IN THE ROCKET POD/CONTAINER (RP/C). SUBSEQUENT REFERENCE TO CONTAINER HEREIN MEANS THE RP/C WITH ROCKET COMPONENTS. SEE GENERAL NOTES "U", "V", AND "W" FOR STORAGE HANDLING AIDS. ALSO SEE GENERAL NOTE "X".

- C. FOR DETAILS OF THE ROCKET POD/CONTAINER, SEE US ARMY MISSILE COMMAND DRAWING NO. 13027900 AND THE "CONTAINER DETAIL" ON PAGE 3.

CONTAINER DIMENSIONS -- 166" LONG BY 41-1/2" WIDE BY 33"
HIGH (31" STACKING HEIGHT).
GROSS WEIGHT - - - - - 5,095 POUNDS (APPROX).

- D. THIS IS A QD CLASS 1.1 ITEM AND IS IN COMPATIBILITY GROUP E. CAUTION: THIS ITEM IS IN A "PROPULSIVE STATE" AND MUST BE STORED WITH THE FORWARD END FACING TOWARD THE SAME MAGAZINE SIDEWALL OR THE REAR WALL AS INDICATED BY THE DIRECTIONAL ARROWS ON THE STORAGE VIEWS.

- E. THE STORAGE PROCEDURES DEPICTED WITHIN THIS DOCUMENT, INCLUDING ALTERNATIVE PROCEDURES ON PAGES 6, 7, 26, AND 27 ARE APPLICABLE FOR STORAGE IN VARIOUS TYPES AND SIZES OF MAGAZINES. THE STORAGE PROCEDURES DEPICTED FOR THE SPECIFIC TYPES OF MAGAZINES MAY ALSO BE UTILIZED TO STORE CONTAINERS IN OTHER TYPES OF APPROVED MAGAZINES. MINOR ADJUSTMENTS MAY BE MADE TO FACILITATE STORAGE IN OTHER TYPES OF MAGAZINES, HOWEVER, THE BASIC PRINCIPLES AS DEPICTED HEREIN WILL BE FOLLOWED.

- F. STORED CONTAINERS MUST NOT CONTACT THE WALLS OF A MAGAZINE. TO PROVIDE FOR THIS MANDATORY CLEARANCE REQUIREMENT, CONTAINERS MAY BE ELIMINATED FROM THE DEPICTED STORAGE PATTERN OR AISLE DIMENSIONS MAY BE ADJUSTED AS NECESSARY.

- G. AISLE DIMENSIONS AS SHOWN HEREIN MAY BE ADJUSTED TO SUIT LOCAL CONDITIONS AND/OR AVAILABLE MATERIAL HANDLING EQUIPMENT (MHE). AN 18" MINIMUM INSPECTION AISLE MUST BE MAINTAINED AT THE AFT END OF THE ROCKET POD/CONTAINERS FOR INVENTORY PURPOSES AND FOR INSPECTION OF THE WIRING HARNESS AND GROUND CABLE, AND TO ENSURE THAT "SHORTING PLUGS" ARE IN PLACE ON ALL CONTAINERS FOR PROTECTION FROM STATIC ELECTRICITY AND STRAY VOLTAGE. CONTAINERS PRESENTLY STORED IN ACCORDANCE WITH A PRIOR APPROVED DRAWING NEED NOT BE RE-STORED SOLELY TO CONFORM TO THE PROCEDURES SPECIFIED IN THIS REVISED DOCUMENT.

- H. IF AVAILABLE MHE PERMITS, ADDITIONAL CONTAINERS MAY BE STORED WITHIN THE FRONTAL AREA AND/OR OTHER AVAILABLE AREA OF THE MAGAZINE.

- J. CAUTION: CONTAINERS MUST NOT BE STACKED MORE THAN FOUR (4) CONTAINERS HIGH. SEE GENERAL NOTE "X".

- K. ANY ROCKET POD/CONTAINER THAT DOES NOT CONTAIN SIX (6) ROUNDS WILL NOT BE BURIED IN STORAGE. IT SHOULD BE POSITIONED ON TOP OF THE LAST STACK ADJACENT TO OR NEAREST THE MAGAZINE DOOR.

- L. THE SHOCK ISOLATOR (RUBBER) SKIDS OF A ROCKET POD/CONTAINER WILL NOT ADEQUATELY SUPPORT A STACK OF TWO CONTAINERS. THEREFORE, "POD SUPPORT" DUNNAGE MUST BE INSTALLED AS NEAR AS POSSIBLE BEHIND THE SKIDS OF THE LOWER CONTAINER (S) IF STACKS ARE TWO OR MORE HIGH. "POD SUPPORT" DUNNAGE NEED NOT BE IN CONTACT WITH CONTAINER SKIDS. A "POD SUPPORT" IS NOT REQUIRED FOR A ONE-HIGH CONTAINER STACK, OR BETWEEN THE TOP TWO CONTAINERS OF STACKS MORE THAN ONE HIGH. A "POD SUPPORT" CONSISTS OF 4" X 4" X 41-1/2" AND 1" X 4" X 41-1/2" PIECES LAMINATED W/4-6d NAILS. SEE THE DETAIL ON PAGE 3. NOTE THAT FOR STABILITY PURPOSES IT IS DESIRED THAT THE SKIDS OF A LOWER CONTAINER SUPPORT A PORTION OF THE WEIGHT OF THE CONTAINERS ABOVE. THE THICKNESS OF THE "POD SUPPORT" SHOULD BE ADJUSTED AS NECESSARY TO PROVIDE THE PROPER SUPPORT. THE THICKNESS MAY BE REDUCED BY SUBSTITUTING 5/8" OR THINNER BY 3-1/2" WIDE BY 41-1/2" LONG PLYWOOD FOR THE 1" X 4" PIECE. THE THICKNESS MAY BE INCREASED BY ADDING A 1/4" OR THICKER PLYWOOD PIECE. SEE GENERAL NOTES "M" AND "T".

(CONTINUED AT RIGHT)

MATERIAL SPECIFICATIONS

LUMBER - - - - - : SEE TM 743-200-1 (DUNNAGE LUMBER) AND FED SPEC MM-L-751.

NAILS - - - - - : FED SPEC FF-N-105; COMMON.

(GENERAL NOTES CONTINUED)

- M. "POD SUPPORT" DUNNAGE IS NOT REQUIRED IF THE ROCKET POD/CONTAINERS BEING STORED ARE EQUIPPED WITH HARDWOOD SKIDS.
- N. THE HEIGHT OF THE PACKAGE GUARD ON SOME FORKLIFT TRUCKS MAY NOT PERMIT PLACEMENT OF SOME TOP LAYER CONTAINERS IN THE STACKS SHOWN IN THE "SECTION" VIEWS HEREIN, UNLESS TWO UPPER CONTAINERS ARE HANDLED AS ONE LIFT OR THE PACKAGE GUARD IS REMOVED (TINE CARRIAGE WILL IN MOST INSTANCES PROVIDE ADEQUATE PACKAGE GUARD PROTECTION) ONLY A FORKLIFT TRUCK OF ADEQUATE CAPACITY WILL BE USED WHEN LIFTING TWO ROCKET/POD CONTAINERS AS ONE LIFT.
- O. IF THE QUANTITY OF CONTAINERS FOR A MAGAZINE IS TO BE REDUCED FROM WHAT IS SHOWN HEREIN, DUE TO A LIMITED QUANTITY TO BE STORED OR FOR ANY OTHER REASON, THE DELINEATED PROCEDURES ARE TO BE ADJUSTED BY OMITTING STACKS RATHER THAN BY OMITTING LAYERS.
- P. OTHER COMPATIBLE ITEMS MAY BE STORED IN A MAGAZINE WHICH IS PARTIALLY FILLED WITH THE DESIGNATED ITEM.
- Q. DUNNAGE LUMBER SPECIFIED THROUGHOUT THIS PROCEDURAL DRAWING IS OF NOMINAL SIZE. FOR EXAMPLE, 1" X 4" MATERIAL IS ACTUALLY 3/4" THICK BY 3-1/2" WIDE AND 4" X 4" MATERIAL IS ACTUALLY 3-1/2" THICK BY 3-1/2" WIDE.
- R. CAUTION: THE ALLOWABLE "EXPLOSIVE LIMIT" ESTABLISHED FOR A MAGAZINE IS NOT TO BE EXCEEDED.
- S. PORTIONS OF THE MAGAZINES, SUCH AS SIDEWALLS, END WALLS, AND ROOFS HAVE NOT BEEN SHOWN IN THE STORAGE VIEWS FOR CLARITY PURPOSES.
- T. WHEN ROCKET POD/CONTAINERS ARE RECEIVED BY RAIL BOX CAR SHIPMENT, THE CONTAINERS WILL HAVE SPACER ASSEMBLIES AND RISER ASSEMBLIES ATTACHED, OR WILL HAVE SPACER ASSEMBLIES AND STRAPPING BOARDS ATTACHED. A ROCKET POD/CONTAINER HAVING A RISER ASSEMBLY AND A SPACER ASSEMBLY ATTACHED MUST HAVE BOTH OF THOSE ASSEMBLIES REMOVED BEFORE STORING UNLESS THE ROCKET POD/CONTAINER CAN BE PLACED IN THE TOP LAYER OF A STACK. A ROCKET POD/CONTAINER HAVING A SPACER ASSEMBLY AND STRAPPING BOARDS ATTACHED MAY BE STORED IN ANY LOCATION IN A STACK WITHOUT REMOVING THE DUNNAGE. REFER TO PAGES 30 AND 31 FOR FURTHER GUIDANCE.
- U. THE ROCKET POD/CONTAINER IS NOT EQUIPPED WITH FORK TINE OPENINGS AND CHANNELS FOR HANDLING WITH A FORKLIFT TRUCK. THE CONTAINER MAY SHIFT TO ONE SIDE ON THE FORK TINES FROM ITS CENTER OF BALANCE, POSSIBLY CREATING A HAZARD OR RESULTING IN DAMAGE TO THE CONTAINER. TO PREVENT SUCH AN OCCURRENCE, IT IS RECOMMENDED THAT AN "MLRS POD STABILIZING FRAME" BE USED FOR HANDLING EACH CONTAINER FOR UNLOADING FROM TRANSPORT VEHICLE TO PLACING IN ITS STORAGE LOCATION. SUCH A STABILIZING FRAME HAS BEEN DESIGNED, FABRICATED AND IS BEING SUCCESSFULLY USED. SEE GENERAL NOTE "W" FOR APPLICABLE FABRICATION DRAWINGS.
- V. TO FACILITATE MOVEMENT OF THE LONG RP/Cs THRU THE NARROW DOOR OPENINGS OF MOST TYPES OF STORAGE MAGAZINES, A "STORAGE HANDLING AID" HAS BEEN DESIGNED, FABRICATED AND USED. THE STORAGE AID CONSISTS OF A METAL RAMP AND WHEELED DOLLY. THIS AID PROVIDES FOR AN EFFICIENT OPERATION WITH A FORKLIFT TRUCK UNLOADING A CONTAINER FROM A TRANSPORT VEHICLE PLACING THE CONTAINER ON THE WHEELED DOLLY ON THE RAMP AND ROLLING THE CONTAINER THROUGH THE NARROW DOOR OPENING INTO THE MAGAZINE WITH AN ELECTRIC PALLET JACK, TO PERMIT A FORKLIFT TRUCK WITHIN THE MAGAZINE TO REMOVE THE CONTAINER FROM THE DOLLY AND PLACE IT IN THE DESIGNATED STORAGE LOCATION. SEE GENERAL NOTE "W" FOR APPLICABLE FABRICATION DRAWINGS.
- W. FABRICATION DRAWINGS FOR THE STORAGE AIDS DESCRIBED IN NOTES "U" AND "V" ARE AVAILABLE FROM THE DIRECTOR, US ARMY DEFENSE AMMUNITION CENTER AND SCHOOL (USADACS). ATTN: SMCAC-DES, SAVANNA IL. 61074, DSN 585-8080/8096. THE DRAWING NUMBERS AND TITLES ARE AS FOLLOWS: AC200000809; MLRS POD STABILIZING FRAME USED W/6K FORKLIFT. ACV00140, MLRS STORAGE HANDLING AID FOR NARROW DOOR MAGAZINES.
- X. CAUTION: WHEN STACKING ROCKET POD/CONTAINERS (RP/Cs) THE ALIGNMENT HOLES IN THE SHOCK ISOLATOR SKIDS OF AN UPPER CONTAINER MUST BE PROPERLY ALIGNED WITH THE STACKING PINS OF A LOWER CONTAINER TO PRECLUDE UNDUE STRESS ON THE SHOCK ABSORBERS AND FRAME AND TO PROVIDE FOR STABILITY OF THE STACK.

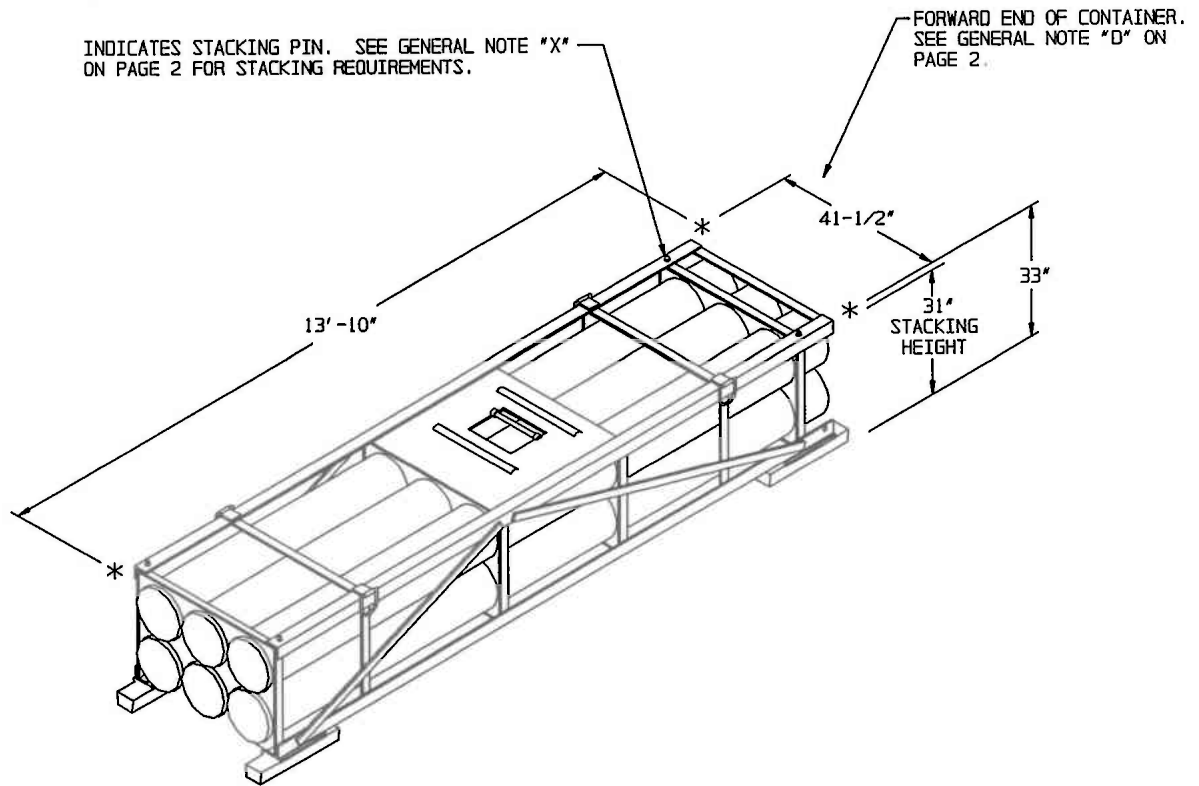

CONTAINER DETAIL

REVISIONS

REVISION NO. 1, DATED AUGUST 1986, CONSISTS OF:

1. RECONFIGURATION OF THE FRONTAL AREA OF THE STRADLEY AND OVAL ARCH MAGAZINES TO INCREASE THE NUMBER OF STORED CONTAINERS.
2. ADDING NOTES AND VIEWS TO ALLOW STORAGE OF LAUNCH POD/CONTAINERS WITH SPACER AND RISER ASSEMBLIES ATTACHED.

REVISION NO. 2 DATED APRIL 1989, CONSISTS OF:

1. REMOVING THE REQUIREMENT FOR FLOOR DUNNAGE.
2. CHANGING THE ITEM NOMENCLATURE TO ROCKET POD/CONTAINER (RP/C).
3. QUALIFYING THE ALLOWANCE FOR STORAGE OF ROCKET POD/CONTAINERS WITH ATTACHED RISER ASSEMBLIES.
4. ADDING AN ALTERNATIVE METHOD OF STORAGE IN TYPE III 60'-0" LONG X 40'-0" WIDE BUNKER MAGAZINE.

REVISION NO. 3, DATED MAY 1991, CONSISTS OF:

1. ADDING ALTERNATIVE STORAGE PROCEDURES ON PAGES 6 AND 7 FOR 81'-0", 60'-8" AND 40'-4" L X 26'-6" W X 12'-9" H IGLOO MAGAZINES AND CHANGING PAGE NUMBERS ACCORDINGLY.
2. REVISING GENERAL NOTES AS APPLICABLE, PARTICULARLY NOTE "G" AS PERTAINS TO INSPECTION AISLES.
3. CORRECTING CONTAINER STACKING HEIGHT AND ADDING FOURTH LAYER TO SOME STACKS IN TYPE III AND TYPE IV BUNKER MAGAZINES, PAGES 24 THRU 29.
4. ADDING GENERAL NOTES "U", "V", AND "W" REGARDING STORAGE HANDLING AIDS AND APPLICABLE DRAWINGS FOR FABRICATION.
5. ADDING GENERAL NOTE "X" REGARDING STACKING REQUIREMENTS.

REVISION NO. 4, DATED OCTOBER 1992, CONSISTS OF:

1. REVISING GENERAL NOTE "G" REGARDING "SHORTING PLUGS" ON CONTAINERS.
2. REVISING GENERAL NOTE "L" DELETING THE REQUIREMENT FOR CONTAINER SHOCK ISOLATOR (RUBBER) SKIDS CONTACTING THE MAGAZINE FLOOR.

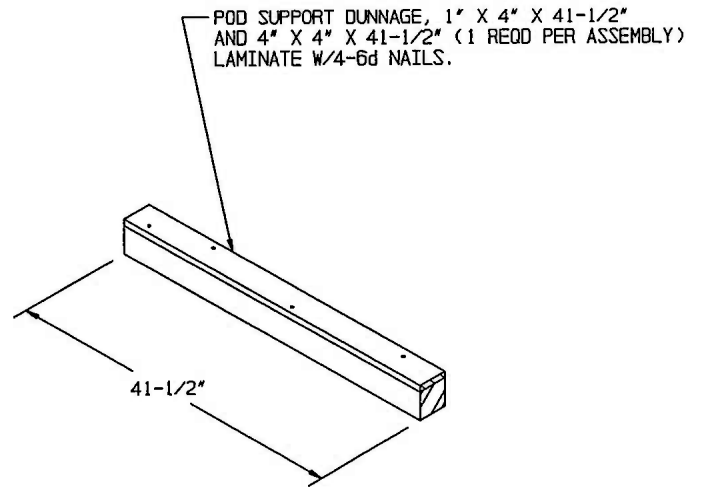

POD SUPPORT ASSEMBLY
SEE GENERAL NOTE "L" ON PAGE 2.

STORAGE IN 81'-0" IGLOO

(12'-9" HIGH)

ITEM QUANTITY

CONTAINER - - - - - 74

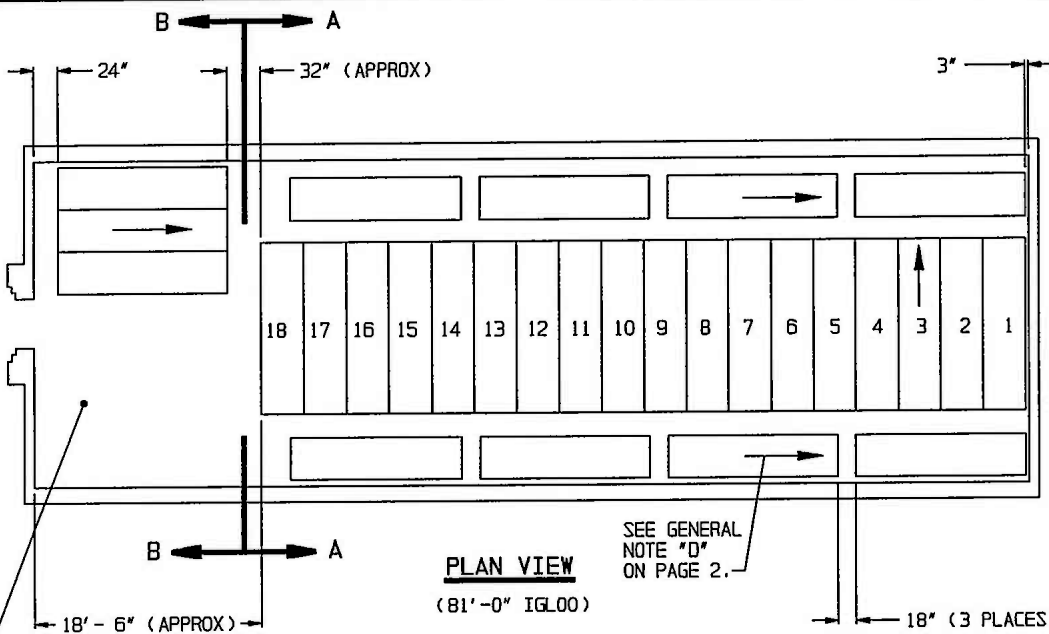

PLAN VIEW
(81'-0" IGLOO)

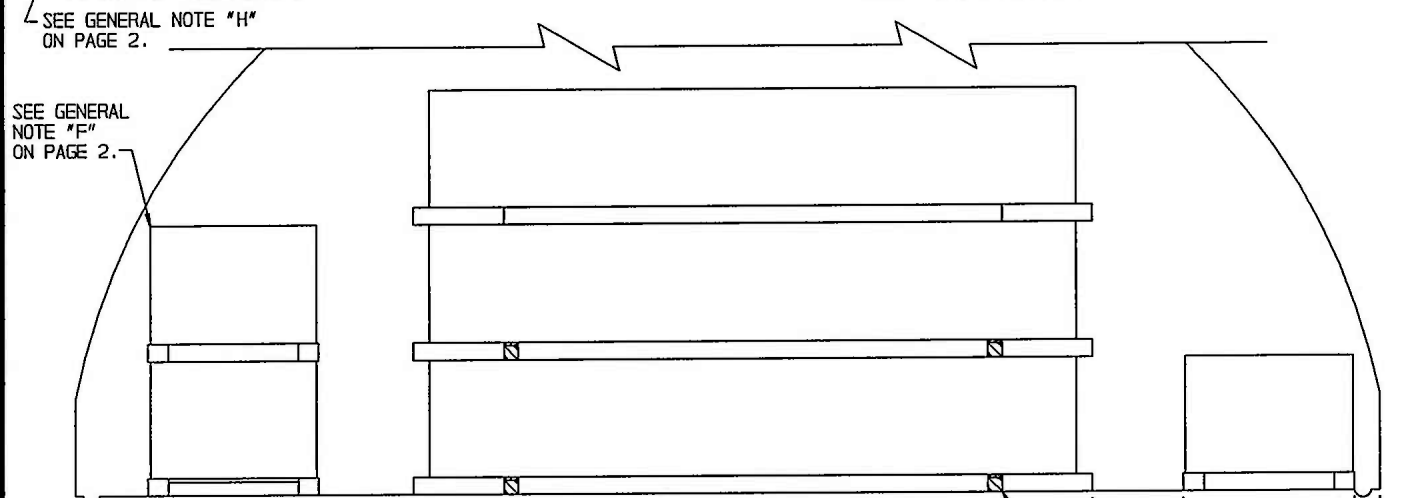

SECTION A-A

POD SUPPORT DUNNAGE. SEE GENERAL NOTE "L" ON PAGE 2, AND DETAIL ON PAGE 3.

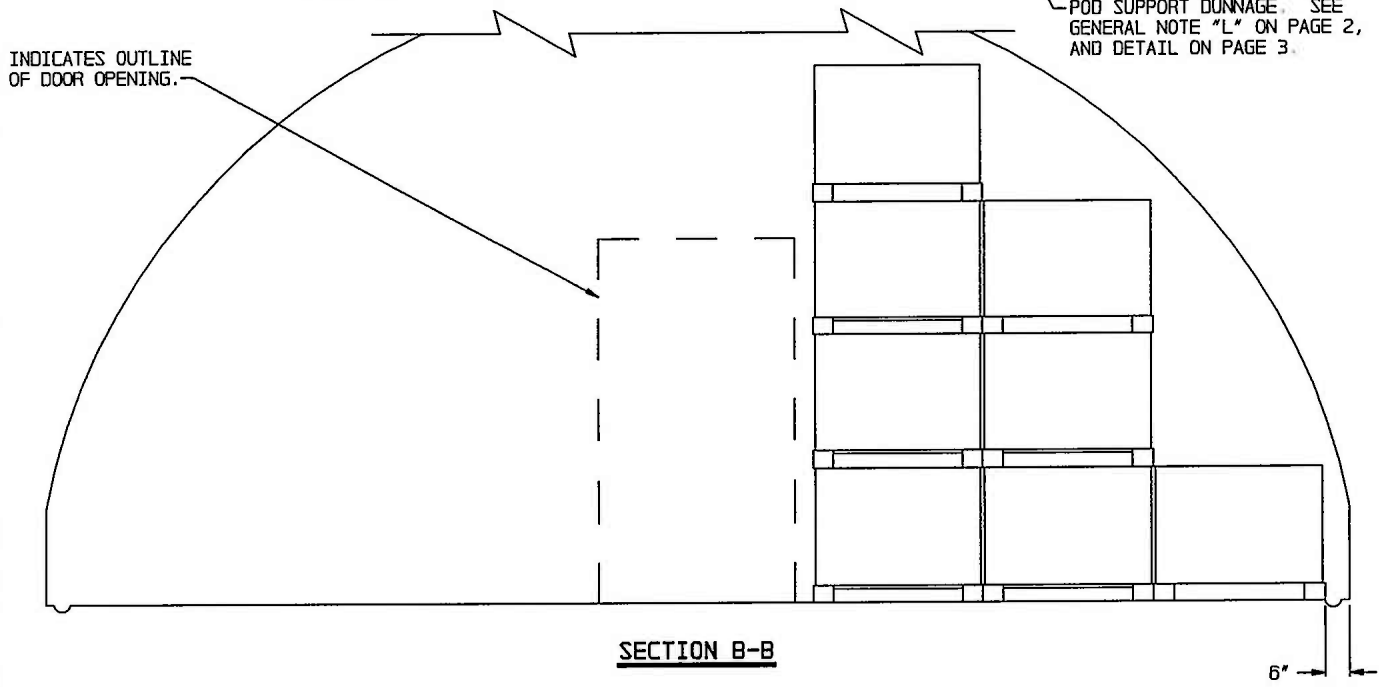

SECTION B-B

STORAGE IN 60'-8" IGL00

(12'-9" HIGH)

ITEM QUANTITY

CONTAINER - - - - - 51

STORAGE IN 40'-4" IGL00

(12'-9" HIGH)

ITEM QUANTITY

CONTAINERS - - - - - 29*

- * 6 CROSSWISE 3-HIGH STACKS
- 1 LENGTHWISE 2-HIGH STACK
- 1 LENGTHWISE 1-HIGH STACK
- 8 FRONTAL AREA CONTAINERS

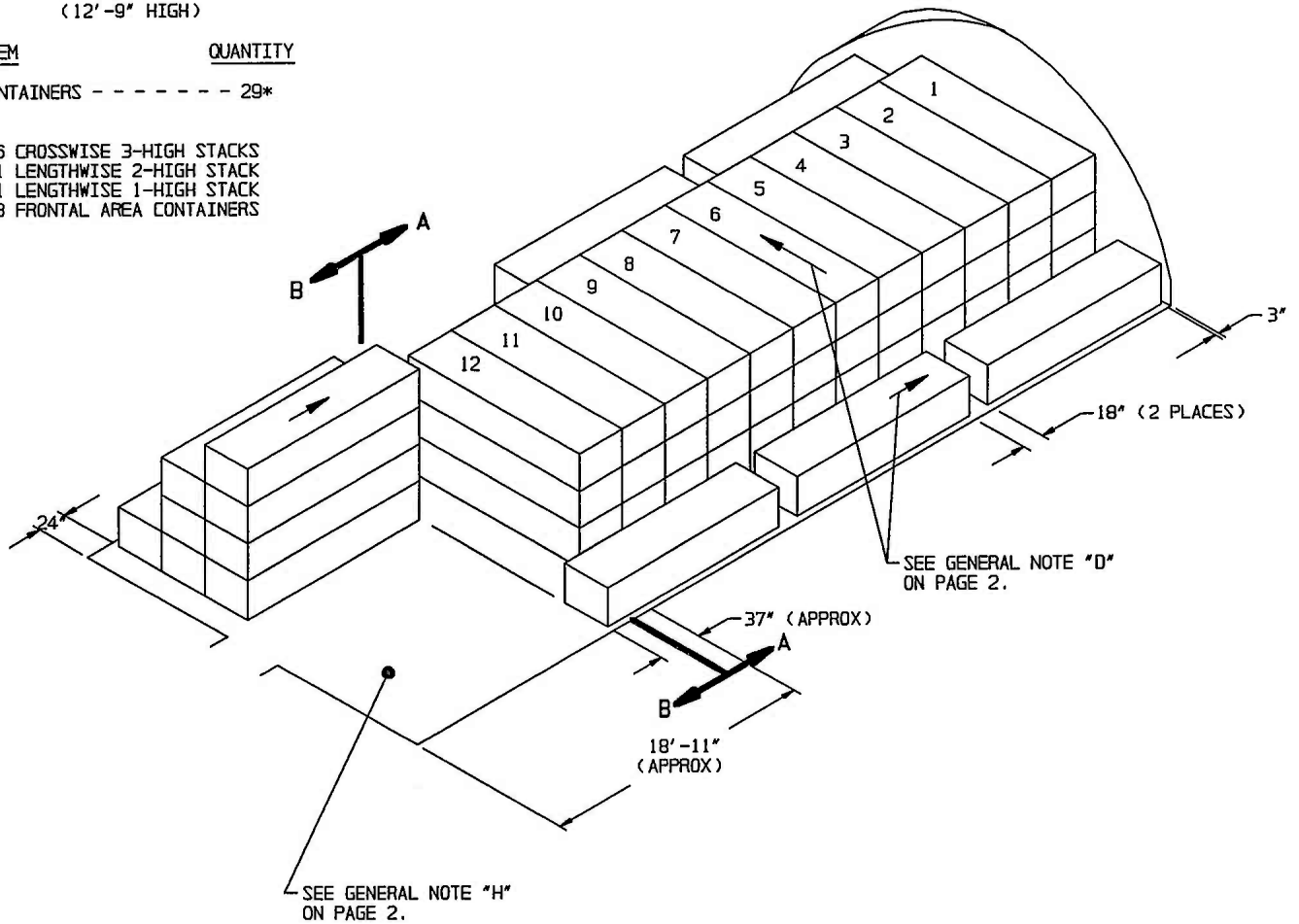

ISOMETRIC VIEW

(60'-8" IGL00)

FOR "GENERAL NOTES" AND "MATERIAL SPECIFICATIONS", SEE PAGE 2.

BILL OF MATERIAL PER CONTAINER STACK					
NO. OF CNTRS HIGH	1" X 4" LUMBER		4" X 4" LUMBER		NAILS 6d (2")
	LINEAR FEET	BOARD FEET	LINEAR FEET	BOARD FEET	
ONE	- - -	- - -	- - -	- - -	- - -
TWO	6.92	2.30	6.92	9.22	8
THREE	13.83	4.61	13.83	18.44	16
FOUR	20.75	6.92	20.75	27.66	24

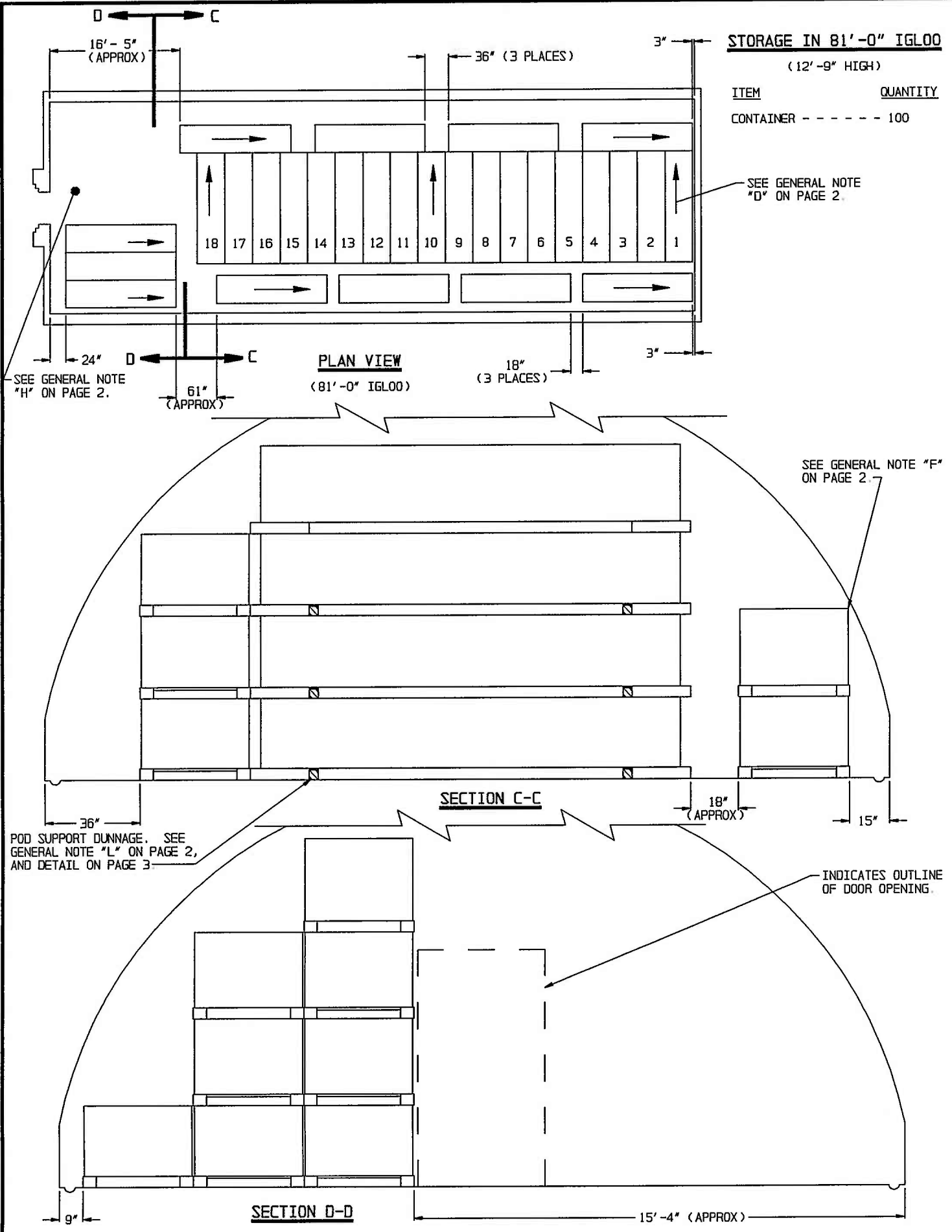

**ALTERNATIVE STORAGE PROCEDURES
IN 81'-0", 60'-8" AND 40'-4" L X 25'-6" W X 12'-9" H IGLOO MAGAZINES**

STORAGE IN 60'-8" IGLOO

(12'-9" HIGH)

ITEM QUANTITY

CONTAINER - - - - - 69

STORAGE IN 40'-4" IGLOO

(12'-9" HIGH)

ITEM QUANTITY

CONTAINER - - - - - 40*

- * 6 CROSSWISE 4-HIGH STACKS
- 2 LENGTHWISE 3-HIGH STACKS
- 1 LENGTHWISE 2-HIGH STACKS
- 8 FRONTAL AREA CONTAINERS

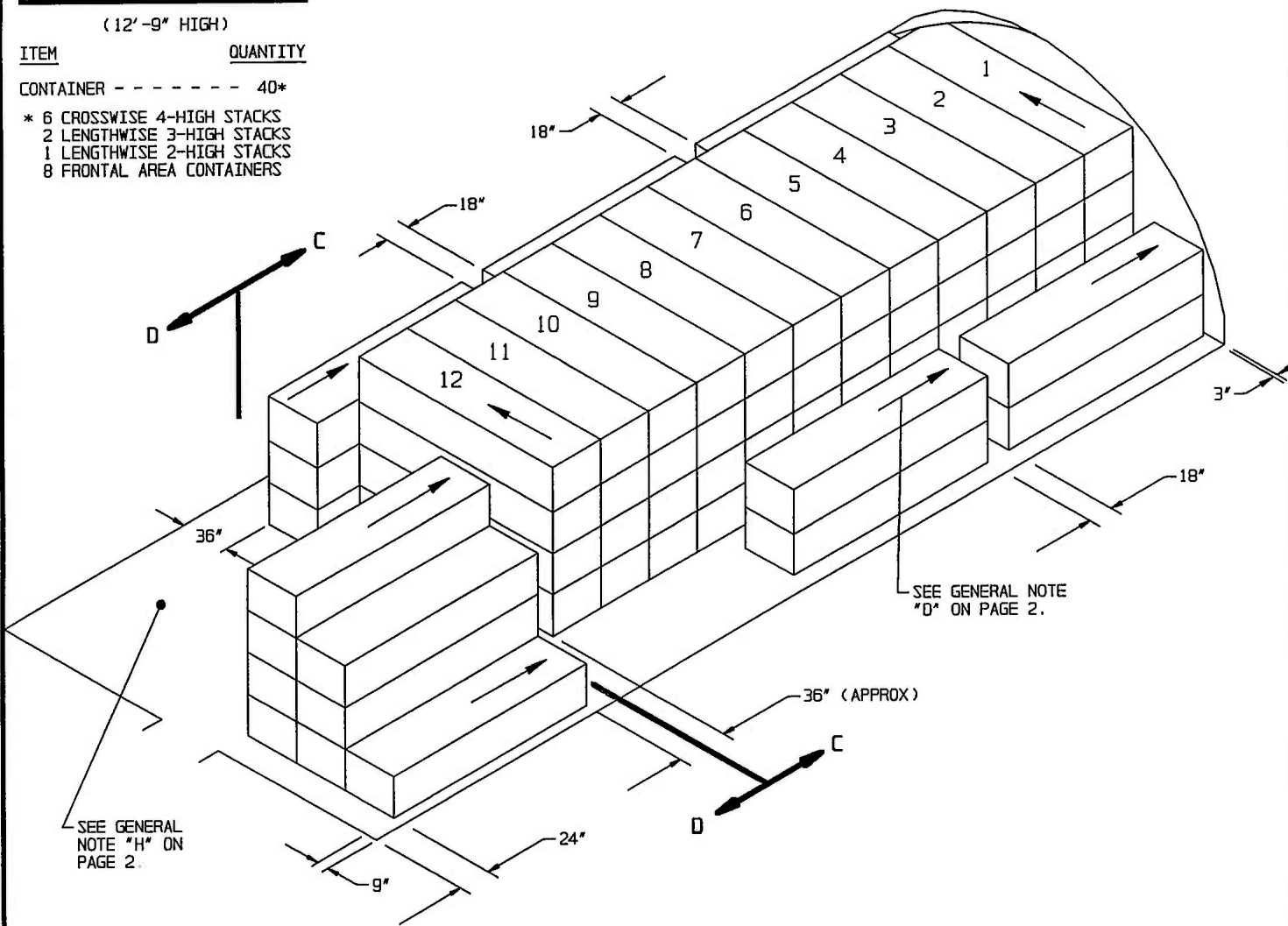

ISOMETRIC VIEW

(60'-8" IGLOO)

FOR "GENERAL NOTES" AND "MATERIAL SPECIFICATIONS",
SEE PAGE 2.

BILL OF MATERIAL PER CONTAINER STACK

NO. OF CNTRS HIGH	1" X 4" LUMBER		4" X 4" LUMBER		NAILS 6d (2")
	LINEAR FEET	BOARD FEET	LINEAR FEET	BOARD FEET	
ONE	- - -	- - -	- - -	- - -	- - -
TWO	6.92	2.30	6.92	9.22	8
THREE	13.83	4.61	13.83	18.44	16
FOUR	20.75	6.92	20.75	27.66	24

ALTERNATIVE STORAGE PROCEDURES
IN 81"-0", 60'-8" AND 40'-4" L X 26'-6" W X 12'-9 H IGLOO MAGAZINES

STORAGE IN 80'-0" MAGAZINE

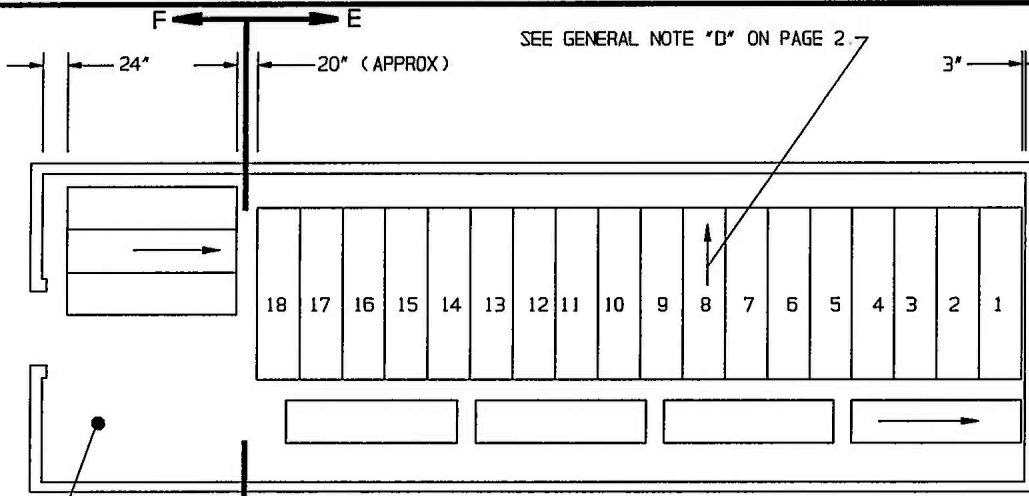

ITEM	QUANTITY
CONTAINER	----- 50

(10'-0" HIGH)



SEE GENERAL NOTE "H" ON PAGE 2.

SEE GENERAL NOTE "F" ON PAGE 2.

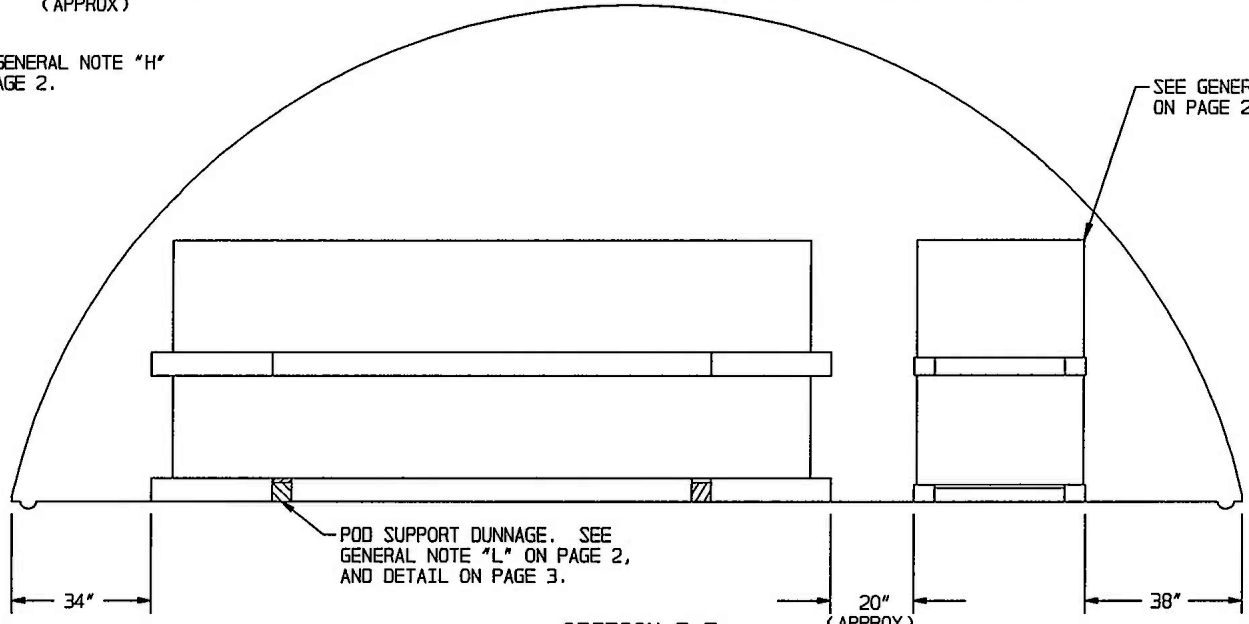

SECTION E-E

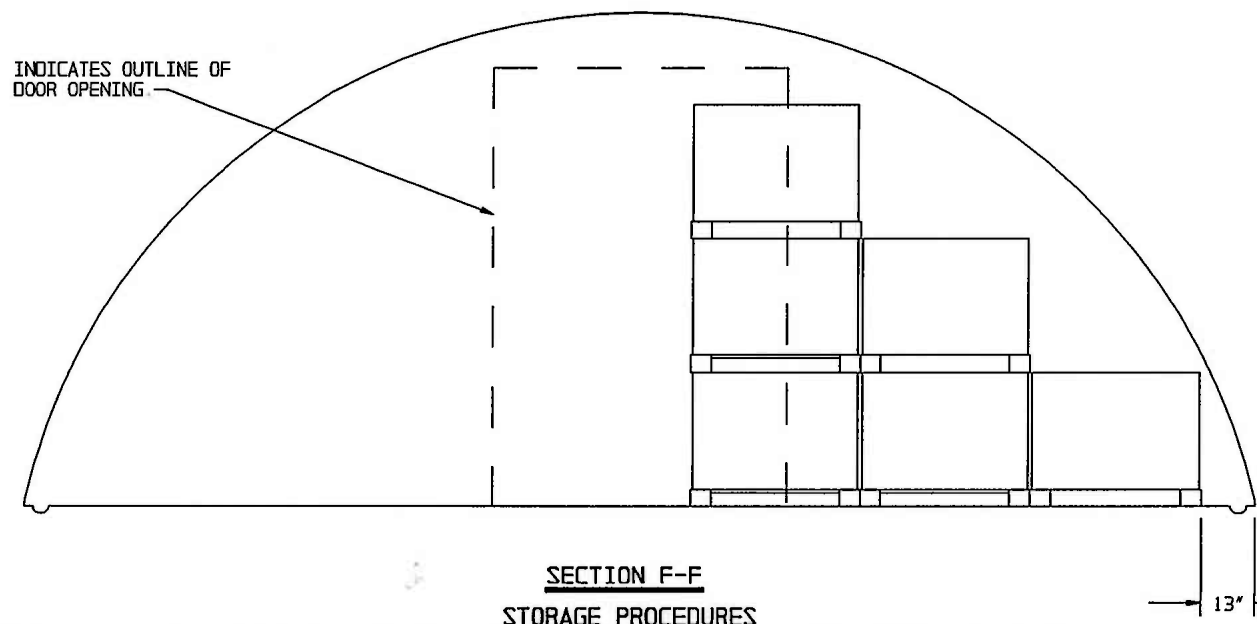

SECTION F-F

STORAGE PROCEDURES IN 80'-0" AND 40'-0" L X 25'-0" W X 10'-0" H ARCH TYPE MAGAZINES (IGLOO)

STORAGE IN 40'-0" MAGAZINE

(10'-0" HIGH)

ITEM QUANTITY

CONTAINER - - - - - 20

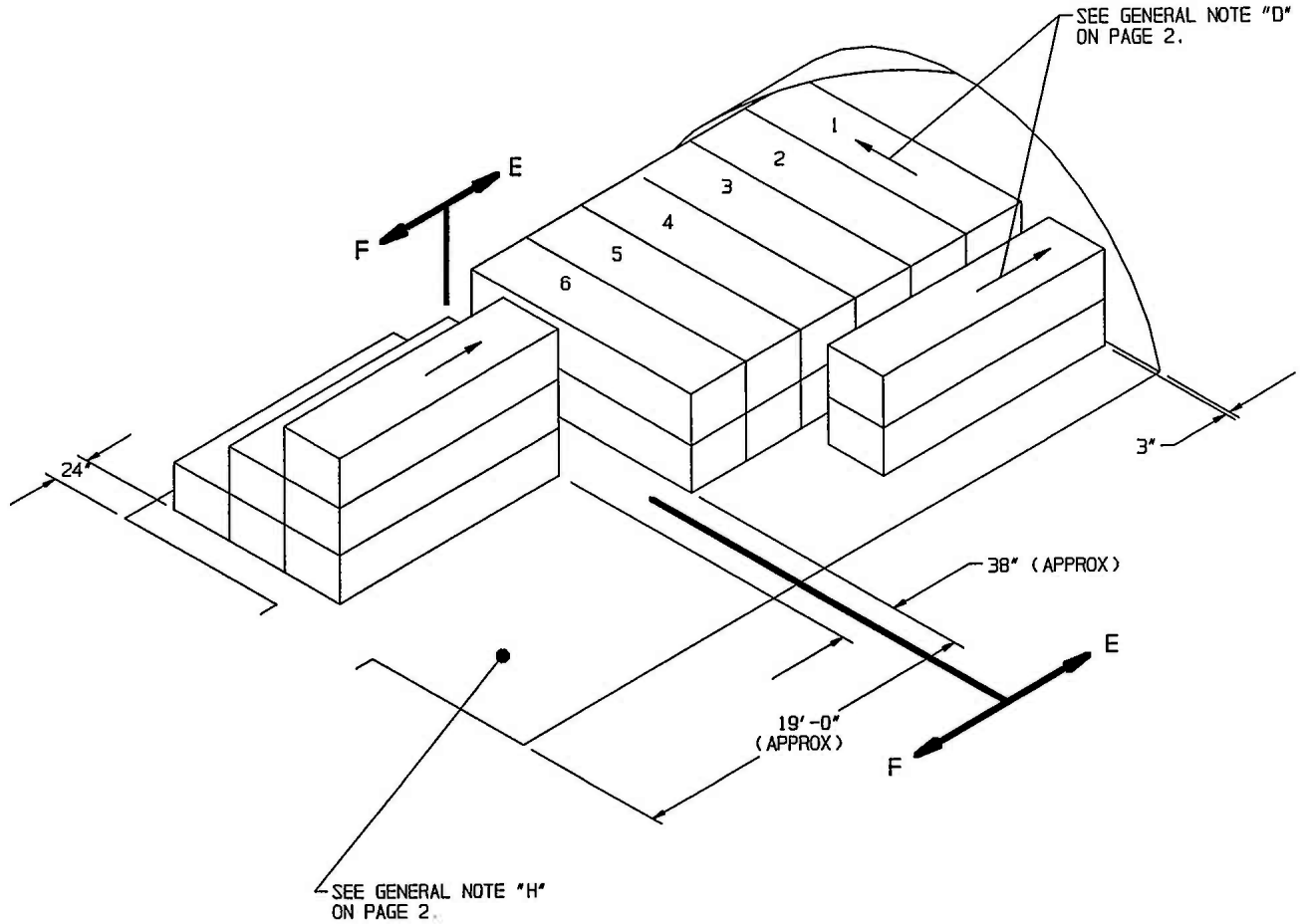

ISOMETRIC VIEW

(40'-0" MAGAZINE)

BILL OF MATERIAL PER CONTAINER STACK					
NO OF CNTRS HIGH	1" X 4" LUMBER		4" X 4" LUMBER		NAILS
	LINEAR FEET	BOARD FEET	LINEAR FEET	BOARD FEET	6d (2")
ONE	- - -	- - -	- - -	- - -	- - -
TWO	6.92	2.30	6.92	9.22	8
THREE	13.83	4.61	13.83	18.44	16

FOR "GENERAL NOTES" AND "MATERIAL SPECIFICATIONS", SEE PAGE 2.

(11'-0" HIGH)

ITEM	QUANTITY
CONTAINER	----- 64

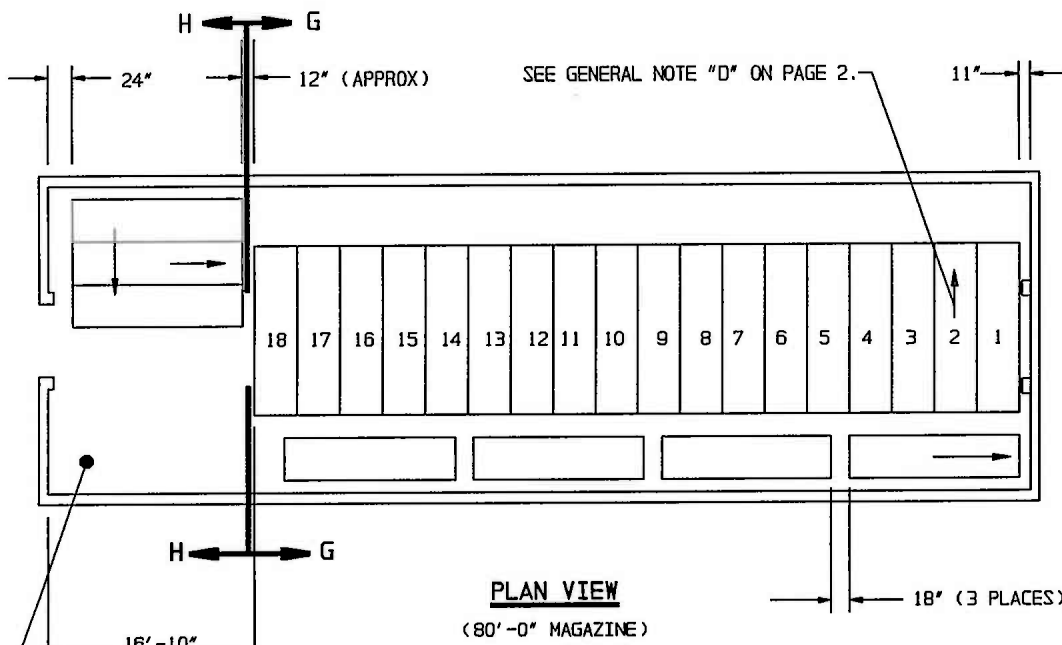

SEE GENERAL NOTE "H" ON PAGE 2.

POD SUPPORT DUNNAGE. SEE GENERAL NOTE "L" ON PAGE 2 AND DETAIL ON PAGE 3.

SEE GENERAL NOTE "F" ON PAGE 2.

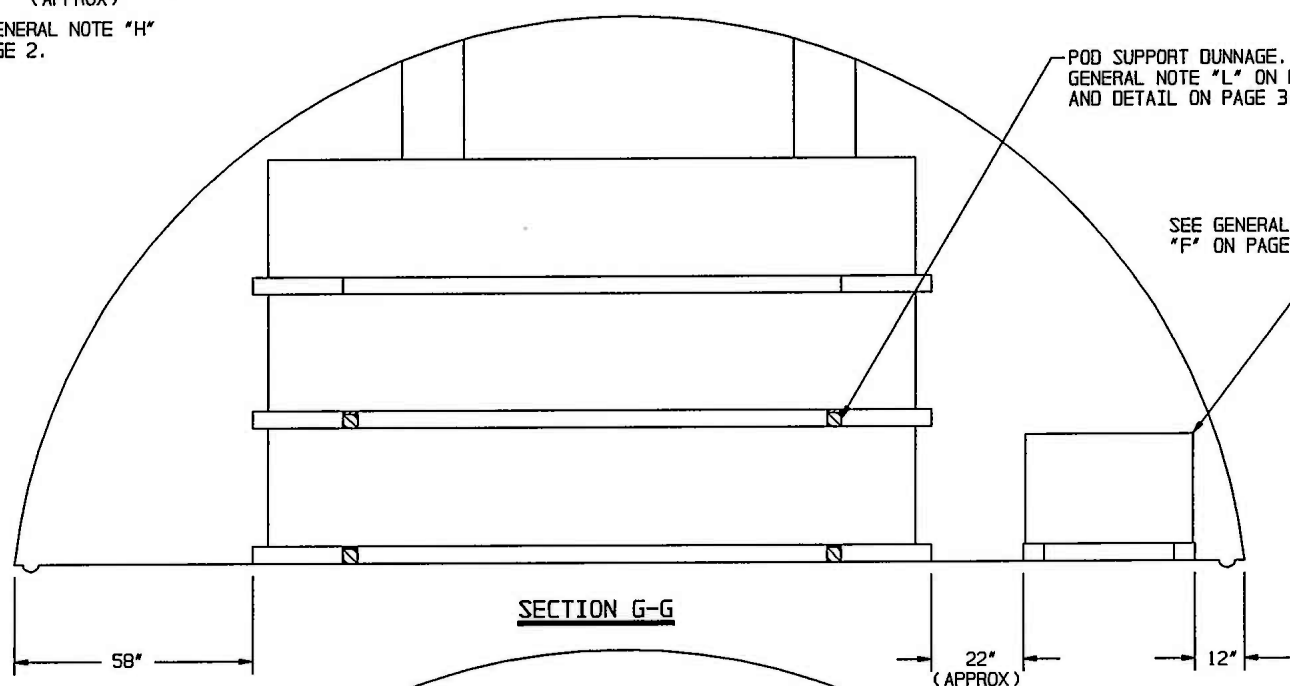

INDICATES OUTLINE OF DOOR OPENING.

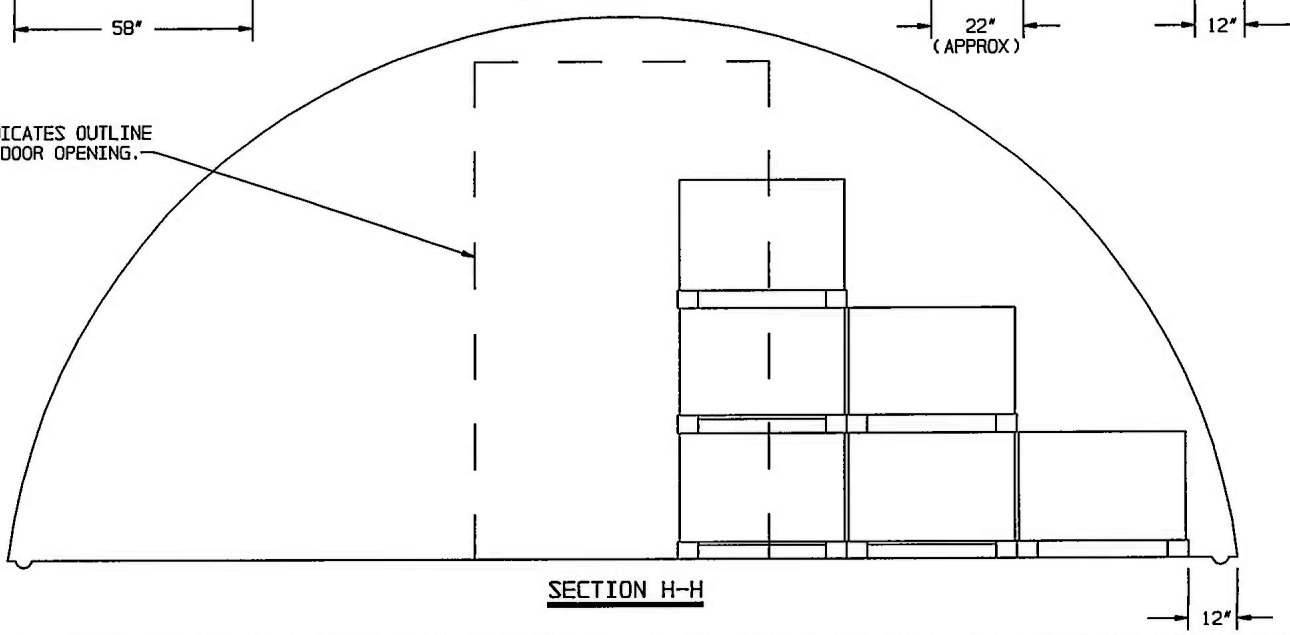

STORAGE IN 40'-0" MAGAZINE

(11'-0" HIGH)

ITEM QUANTITY

CONTAINER - - - - - 25

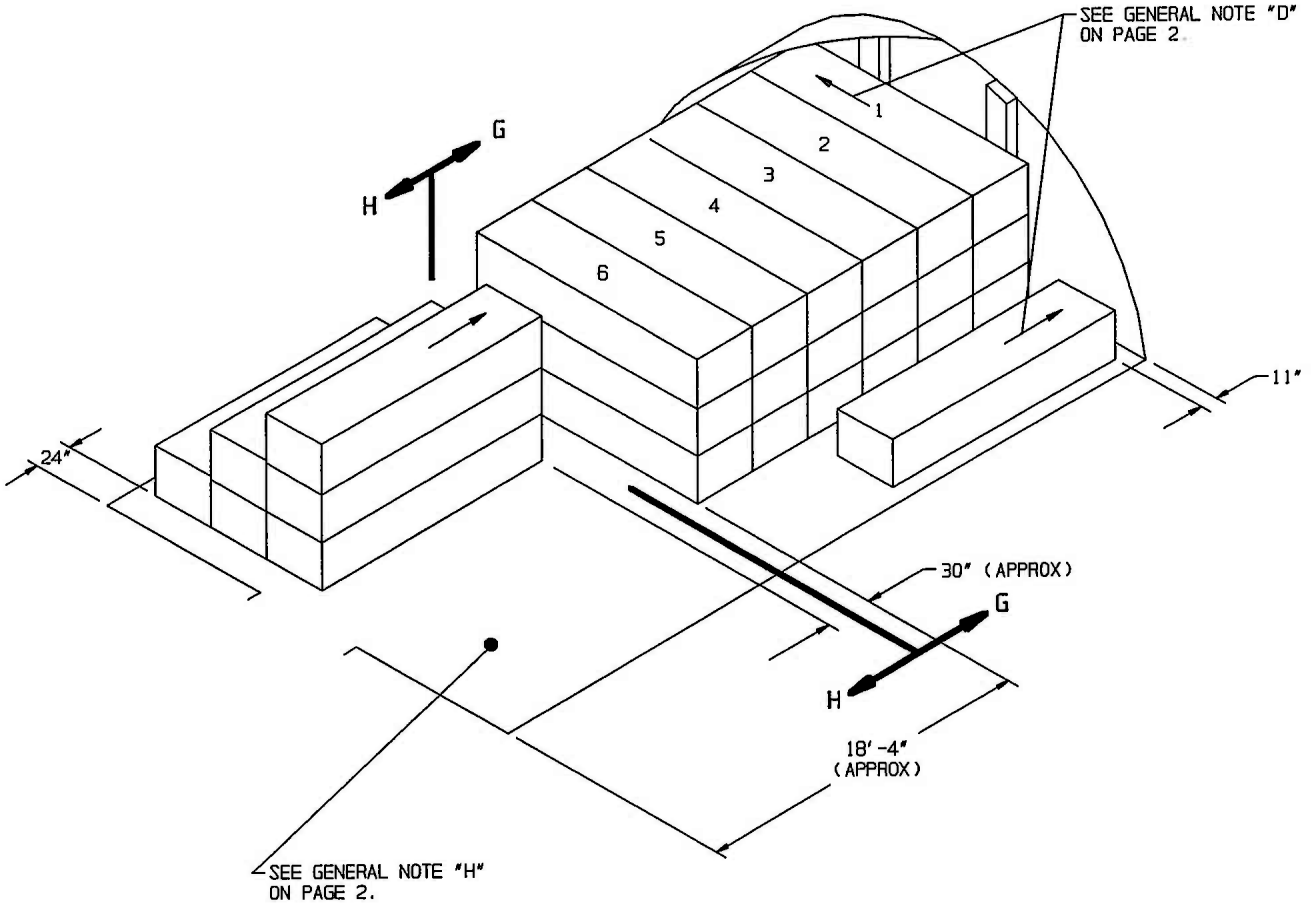

SEE GENERAL NOTE "H" ON PAGE 2.

SEE GENERAL NOTE "D" ON PAGE 2.

ISOMETRIC VIEW

(40'-0" MAGAZINE)

BILL OF MATERIAL PER CONTAINER STACK					
NO. OF CNTRS HIGH	1" X 4" LUMBER		4" X 4" LUMBER		NAILS 6d (2")
	LINEAR FEET	BOARD FEET	LINEAR FEET	BOARD FEET	
ONE	- - -	- - -	- - -	- - -	- - -
TWO	6.92	2.30	6.92	9.22	8
THREE	13.83	4.61	13.83	18.44	16

FOR "GENERAL NOTES" AND "MATERIAL SPECIFICATIONS", SEE PAGE 2.

STORAGE IN 80'-0" MAGAZINE

(12'-1-3/4" HIGH)

ITEM	QUANTITY
CONTAINER - - - - -	70

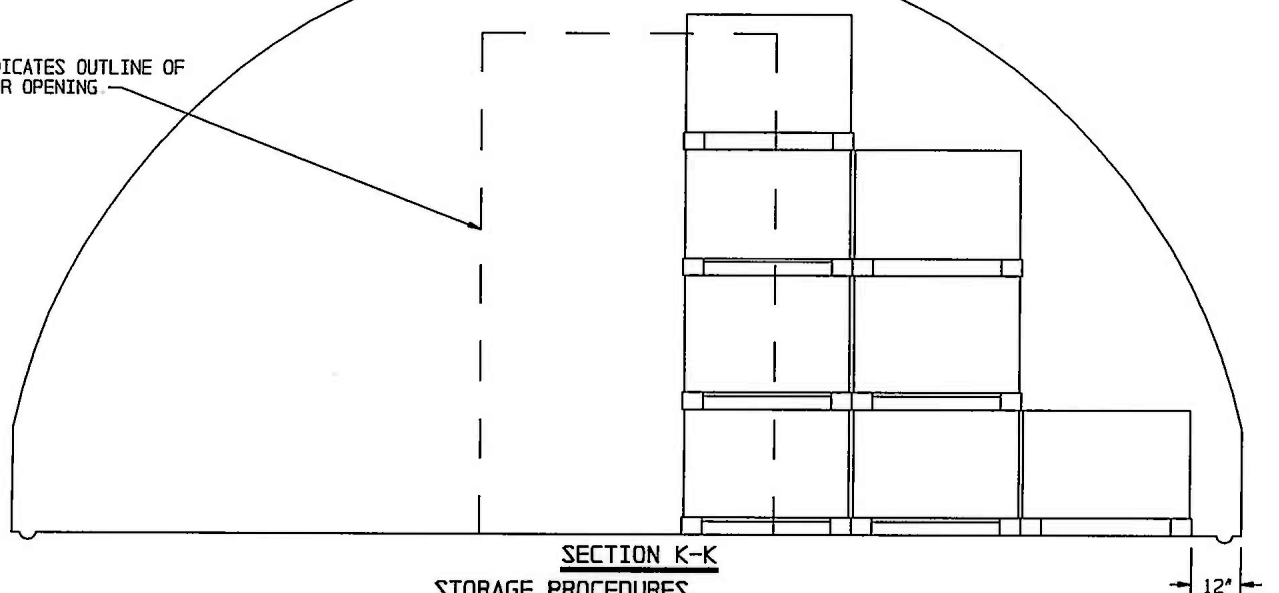
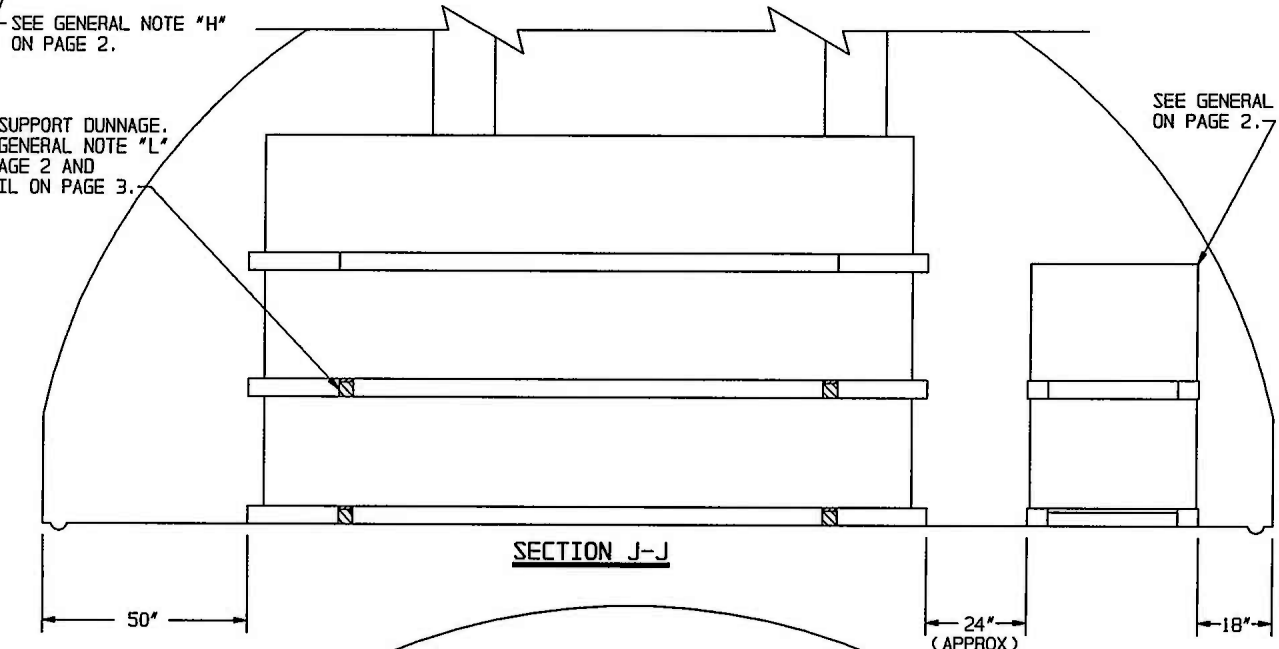
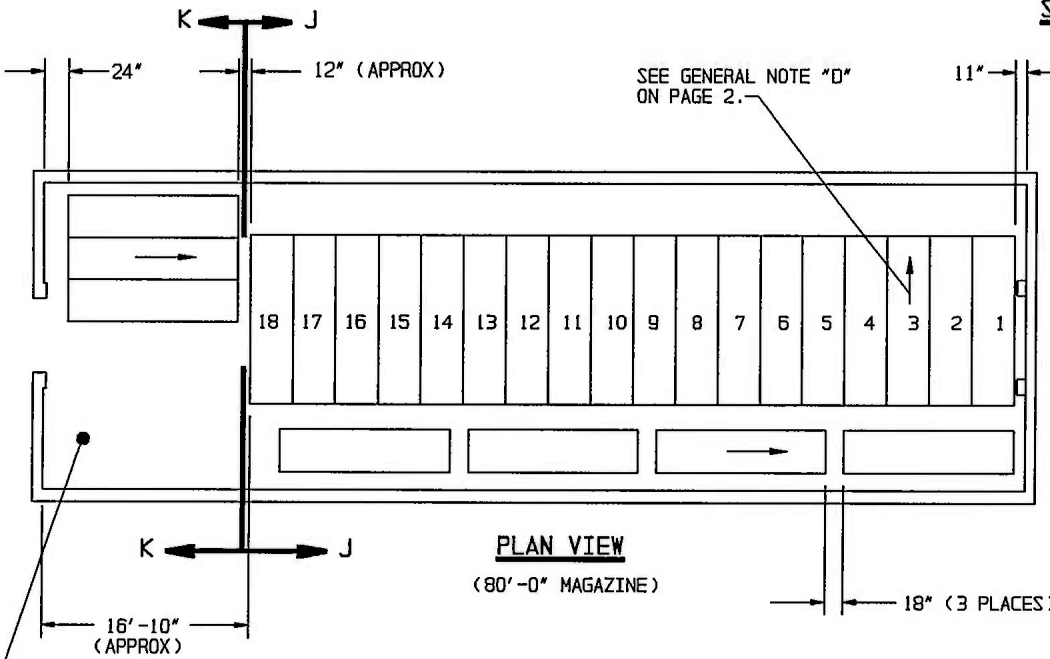

STORAGE PROCEDURES
IN 80'-0" AND 40'-0" L X 25'-0" W X 12'-1-3/4" H ARCH TYPE MAGAZINES (IGLOO)

STORAGE IN 40'-0" MAGAZINE

(12'-1-3/4" HIGH)

ITEM	QUANTITY
CONTAINER - - - - -	28

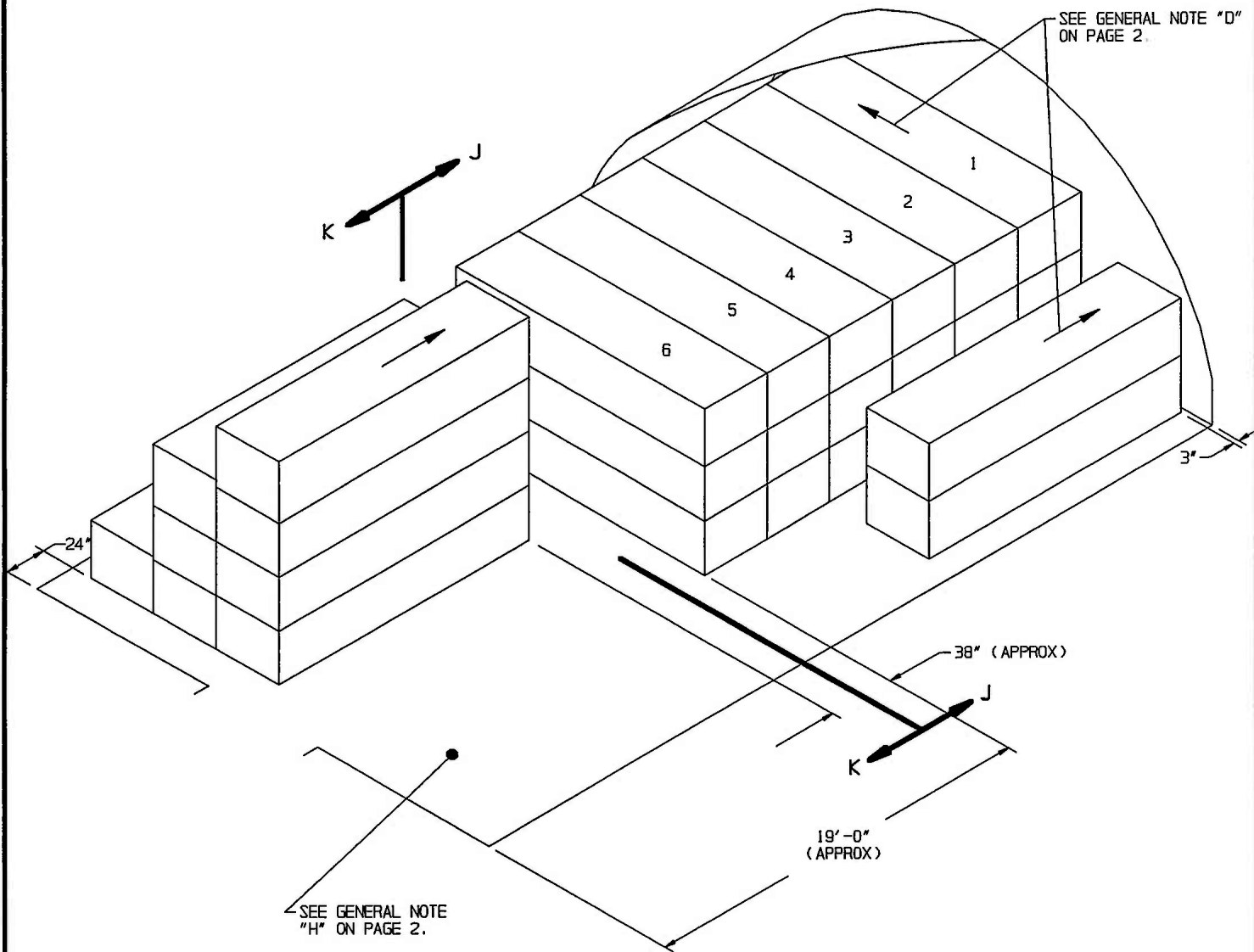

ISOMETRIC VIEW
(40'-0" MAGAZINE)

BILL OF MATERIAL PER CONTAINER STACK					
NO. OF CNTRS HIGH	1" X 4" LUMBER		4" X 4" LUMBER		NAILS 6d (2")
	LINEAR FEET	BOARD FEET	LINEAR FEET	BOARD FEET	
ONE	- - -	- - -	- - -	- - -	- - -
TWO	6.92	2.30	6.92	9.22	8
THREE	13.83	4.61	13.83	18.44	16
FOUR	20.75	6.92	20.75	27.66	24

FOR "GENERAL NOTES" AND "MATERIAL SPECIFICATIONS", SEE PAGE 2.

STORAGE PROCEDURES
IN 80'-0" AND 40'-0" L X 25'-0" W X 12'-1-3/4" H ARCH TYPE MAGAZINES (IGLOO)

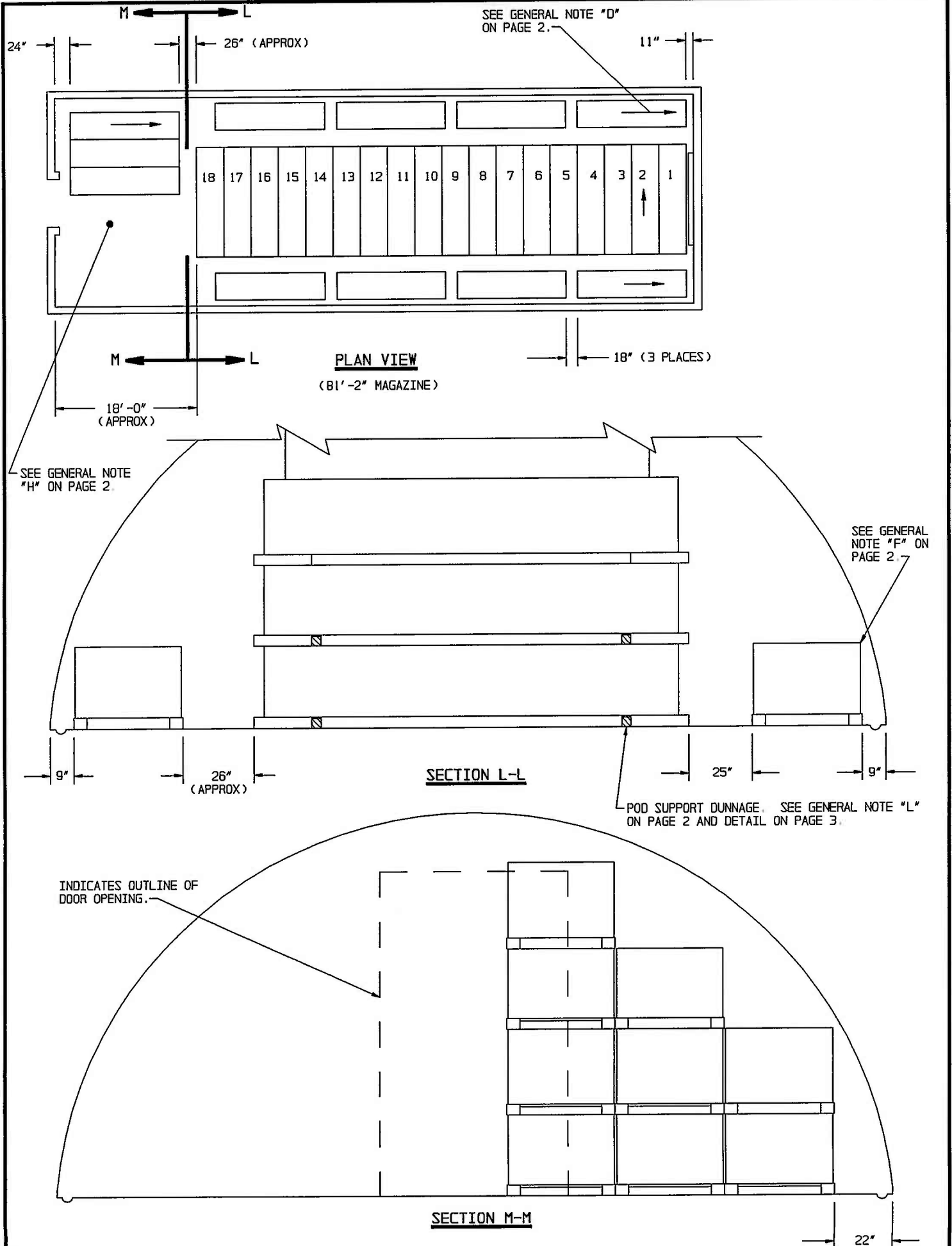

STORAGE IN 81'-2" MAGAZINE

(12'-1-3/4" HIGH)

ITEM

QUANTITY

CONTAINER - - - - - 71

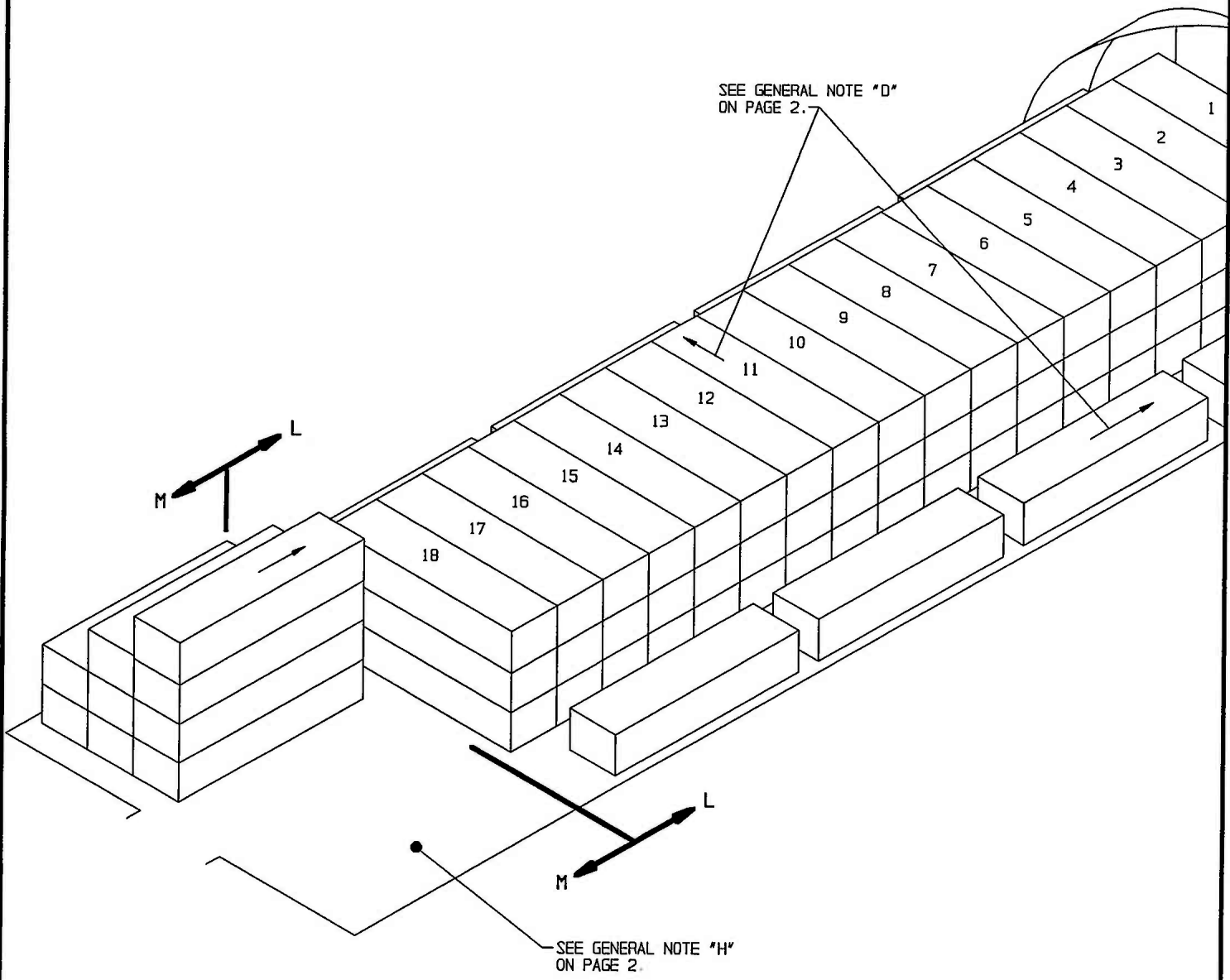

ISOMETRIC VIEW

(81'-2" MAGAZINE)

BILL OF MATERIAL PER CONTAINER STACK					
NO. OF CNTRS HIGH	1" X 4" LUMBER		4" X 4" LUMBER		NAILS 6d (2")
	LINEAR FEET	BOARD FEET	LINEAR FEET	BOARD FEET	
ONE	- - -	- - -	- - -	- - -	- - -
TWO	6.92	2.30	6.92	9.22	8
THREE	13.83	4.61	13.83	18.44	16
FOUR	20.75	6.92	20.75	27.66	24

FOR "GENERAL NOTES" AND "MATERIAL SPECIFICATIONS". SEE PAGE 2.

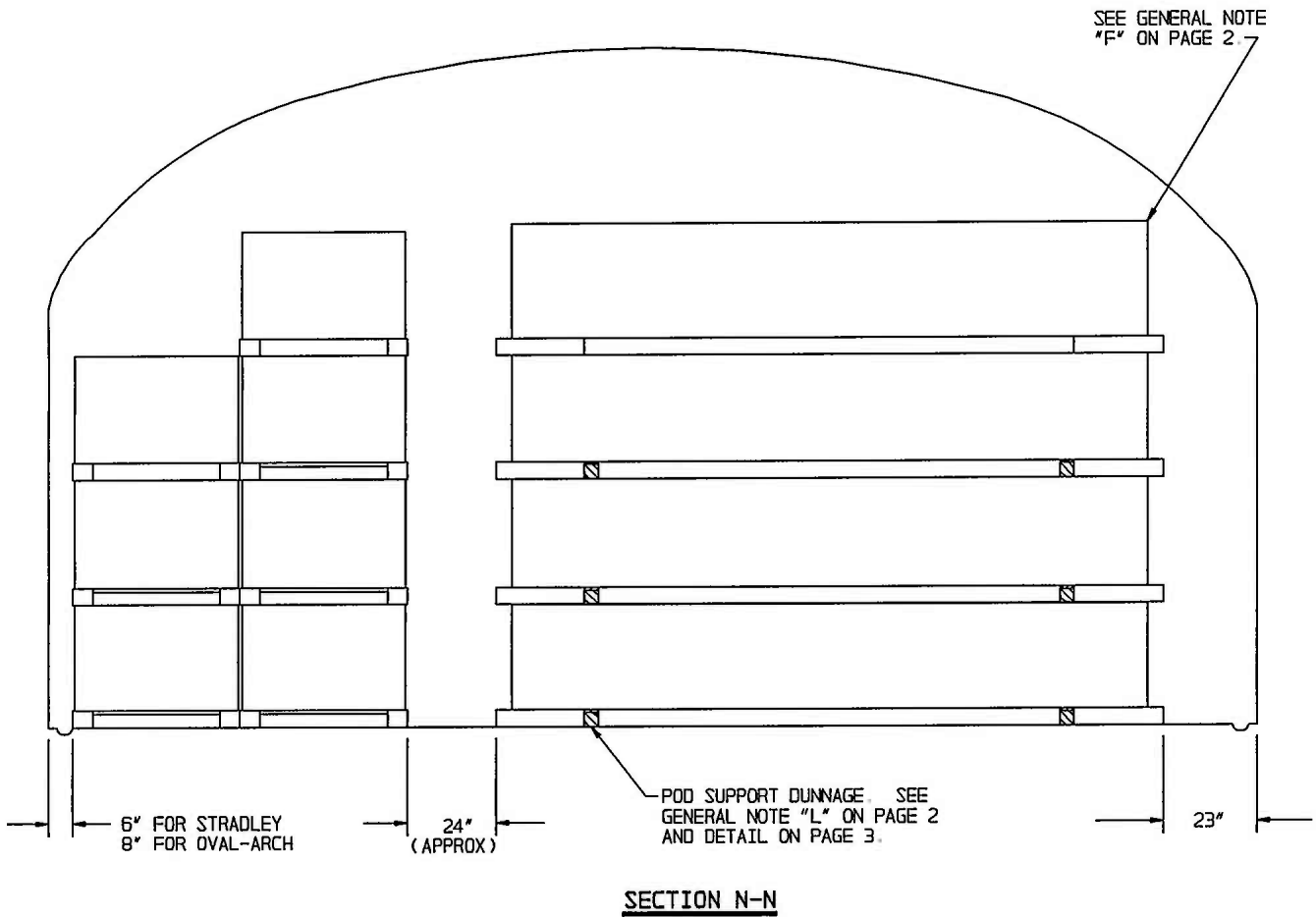
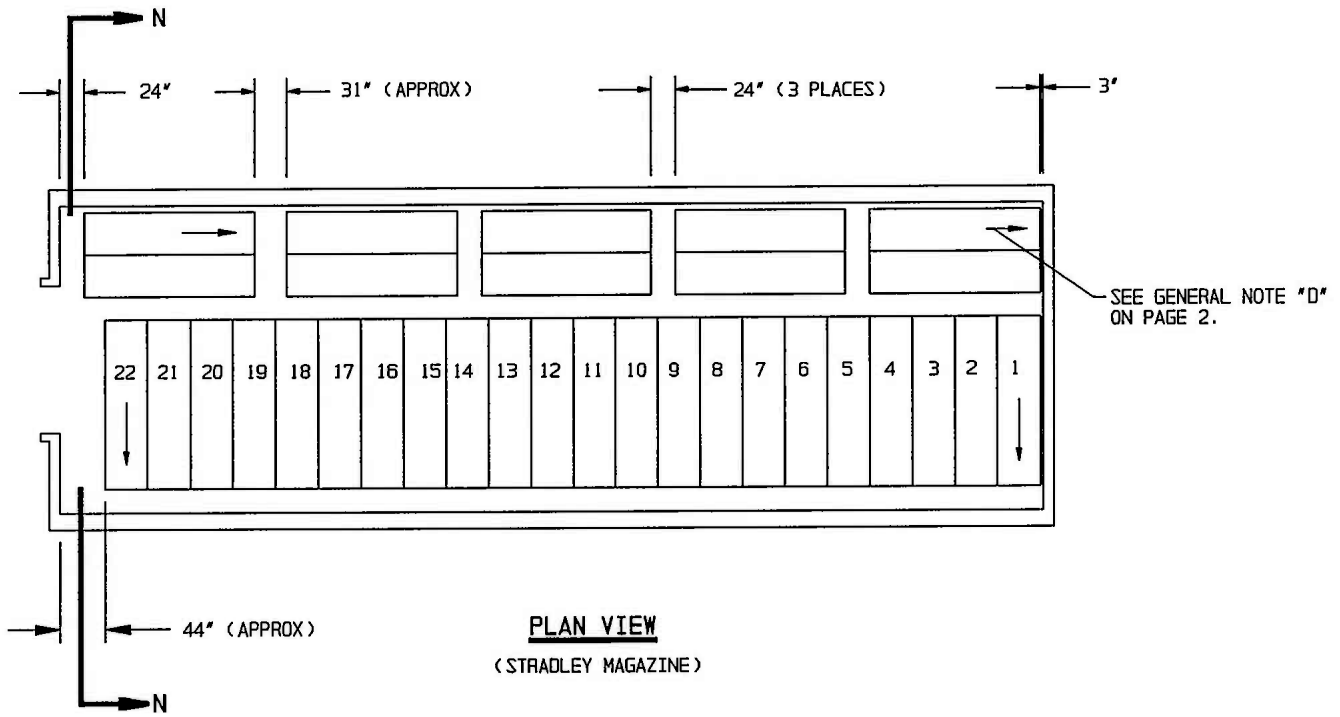

STORAGE PROCEDURES IN 80'-0" L X 25'-0" W X 14'-0" H STRADLEY
AND 89'-0" L X 24'-10" W X 14'-4" H OVAL-ARCH MAGAZINES

STORAGE IN STRADLEY MAGAZINE

ITEM	QUANTITY
CONTAINER - - - - -	120

STORAGE IN OVAL-ARCH MAGAZINE

(89'-0" LONG)

ITEM	QUANTITY
CONTAINER - - - - -	128 *

- * 22 CROSSWISE 4-HIGH STACKS
- 1 CROSSWISE 3-HIGH STACK
- 1 CROSSWISE 2-HIGH STACK
- 5 LENGTHWISE 7-CONTAINER GROUPS

SEE GENERAL NOTE "D" ON PAGE 2.

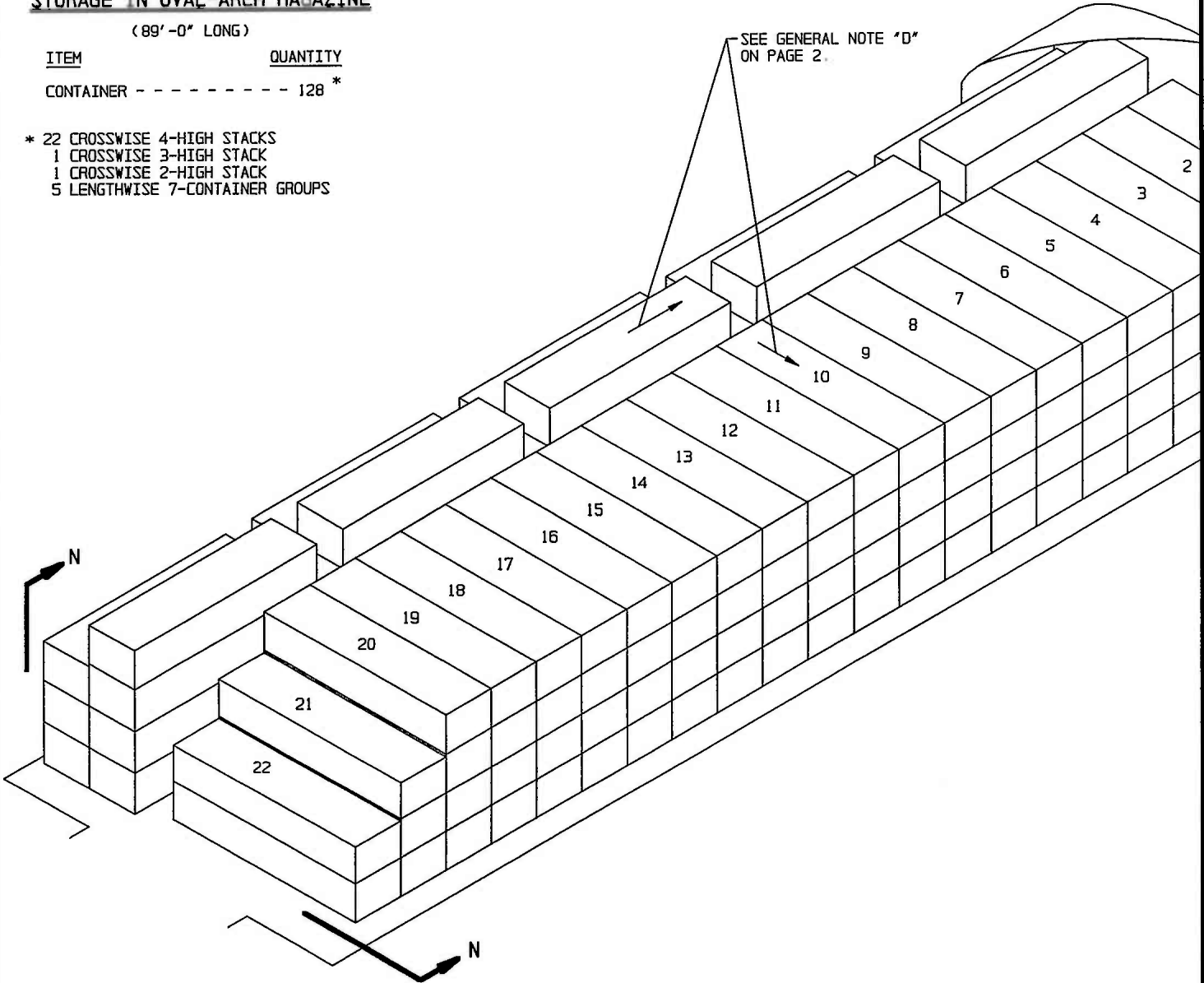

ISOMETRIC VIEW
(STRADLEY MAGAZINE)

BILL OF MATERIAL PER CONTAINER STACK					
NO. OF CNTRS HIGH	1" X 4" LUMBER		4" X 4" LUMBER		NAILS 6d (2')
	LINEAR FEET	BOARD FEET	LINEAR FEET	BOARD FEET	
TWO	6.92	2.30	6.92	9.22	8
THREE	13.83	4.61	13.83	18.44	16
FOUR	20.75	6.92	20.75	27.66	24

FOR "GENERAL NOTES" AND "MATERIAL SPECIFICATIONS", SEE PAGE 2.

STORAGE PROCEDURES IN 80'-0" L X 25'-0" W X 14'-0" H STRADLEY
AND 89'-0" L X 24'-10" W X 14'-4" H OVAL-ARCH MAGAZINES

STORAGE IN 52'-0" DIA MAGAZINE

ITEM	QUANTITY
CONTAINER - - - - -	75

SEE GENERAL NOTE "D" ON PAGE 2.

SEE GENERAL NOTE "H" ON PAGE 2.

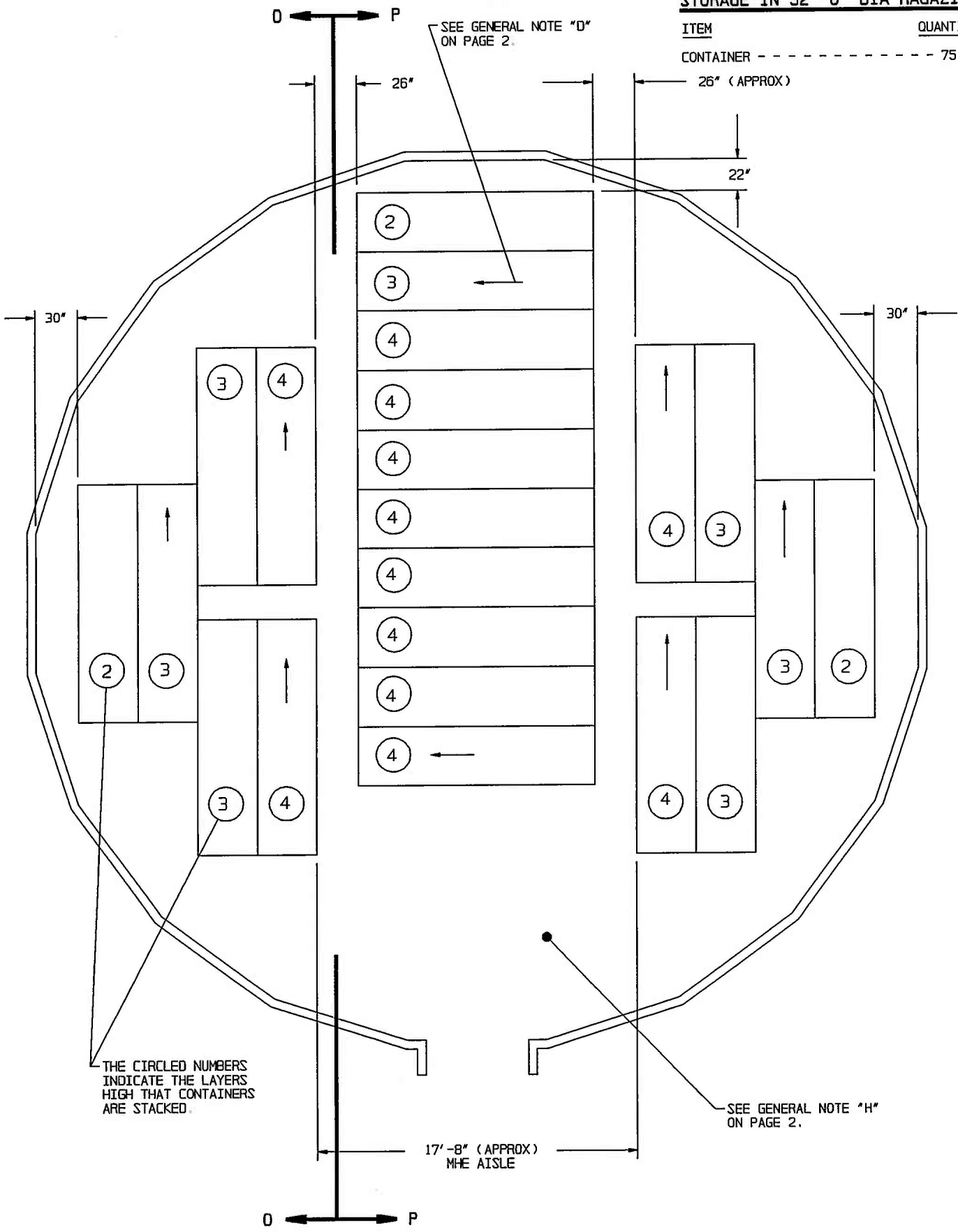

THE CIRCLED NUMBERS INDICATE THE LAYERS HIGH THAT CONTAINERS ARE STACKED.

PLAN VIEW

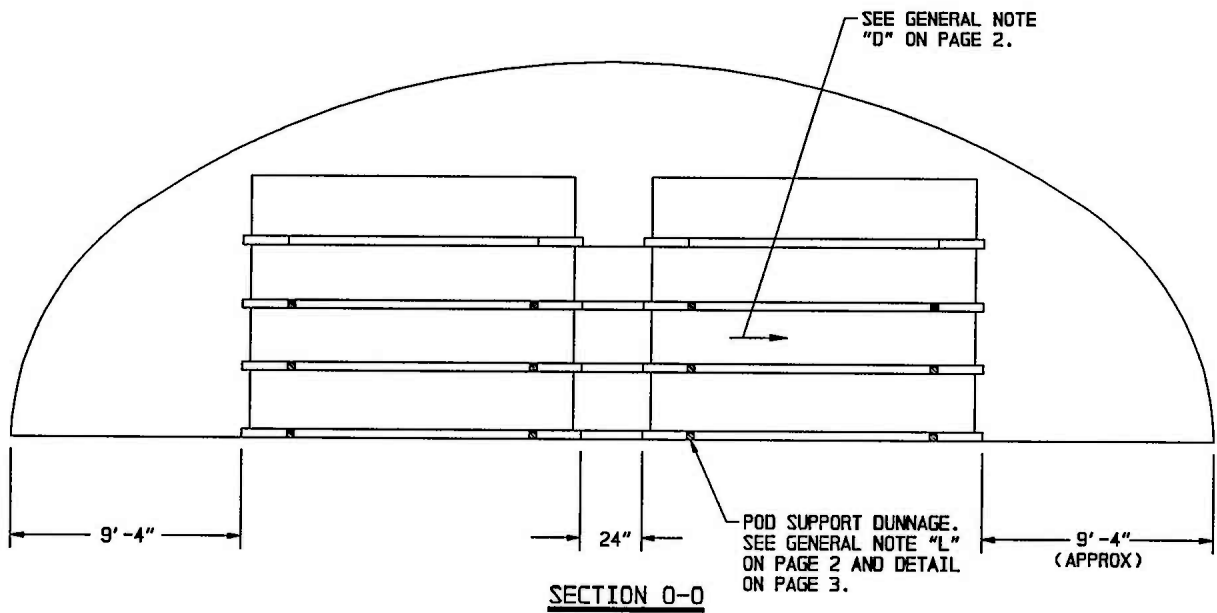

SECTION 0-0

ONLY ONE OF THE ROWS OF CONTAINERS IS SHOWN IN THIS SECTION. UNITS LOCATED IN ADJACENT ROWS OR STACKS HAVE NOT BEEN SHOWN FOR CLARITY PURPOSES.

SEE GENERAL NOTE "F" ON PAGE 2.

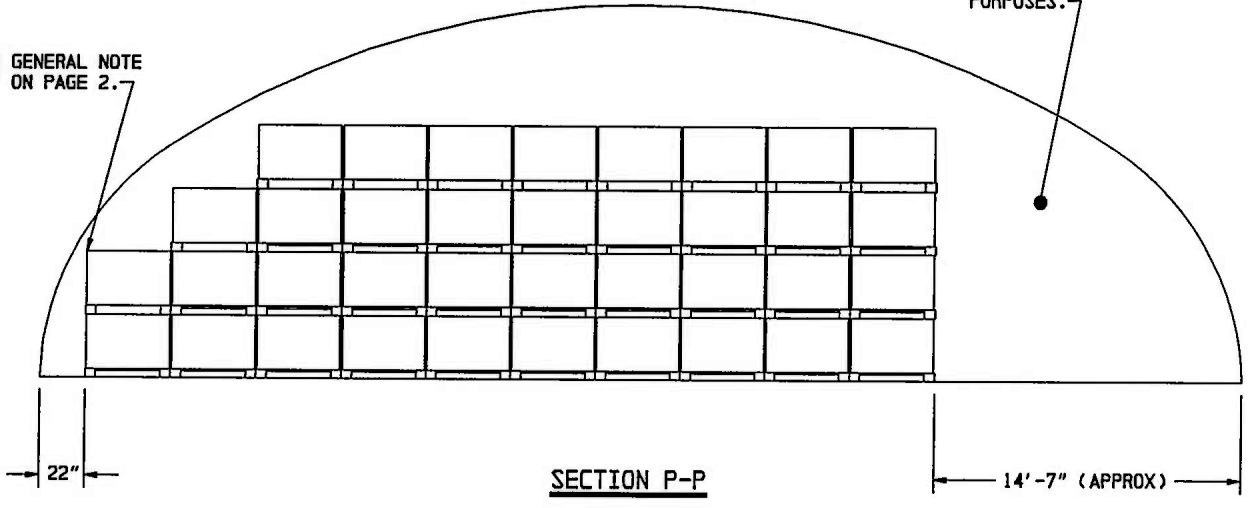

SECTION P-P

BILL OF MATERIAL PER CONTAINER STACK					
NO. OF CNTRS HIGH	1" X 4" LUMBER		4" X 4" LUMBER		NAILS
	LINEAR FEET	BOARD FEET	LINEAR FEET	BOARD FEET	6d (2")
TWO	6.92	2.30	6.92	9.22	8
THREE	13.83	4.61	13.83	18.44	16
FOUR	20.75	6.92	20.75	27.66	24

FOR "GENERAL NOTES" AND "MATERIAL SPECIFICATIONS", SEE PAGE 2.

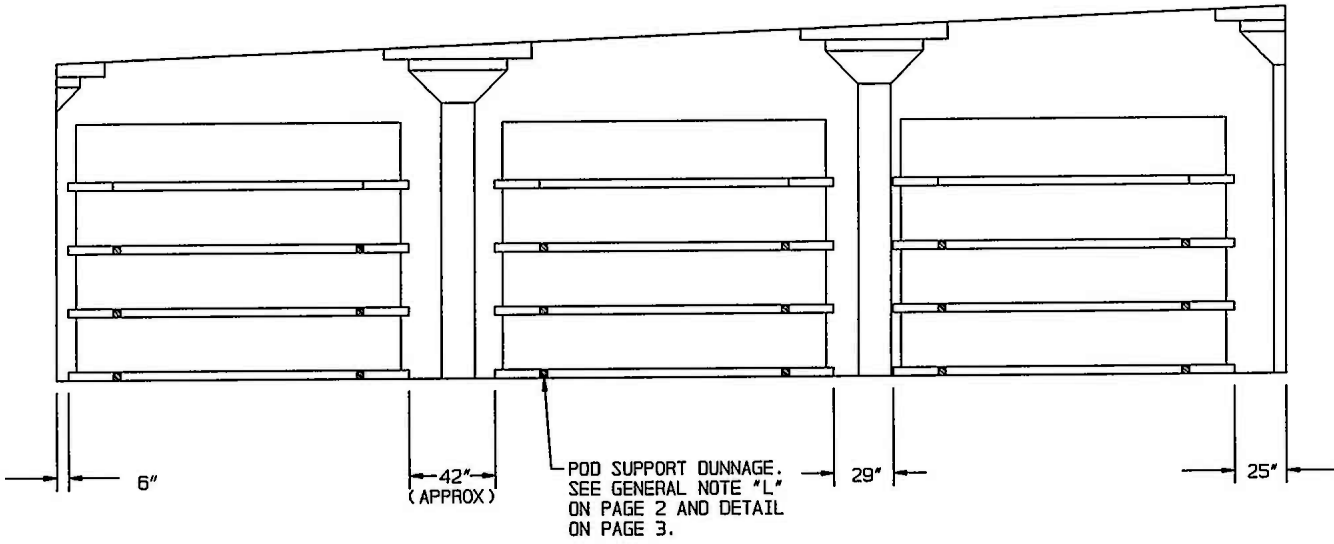
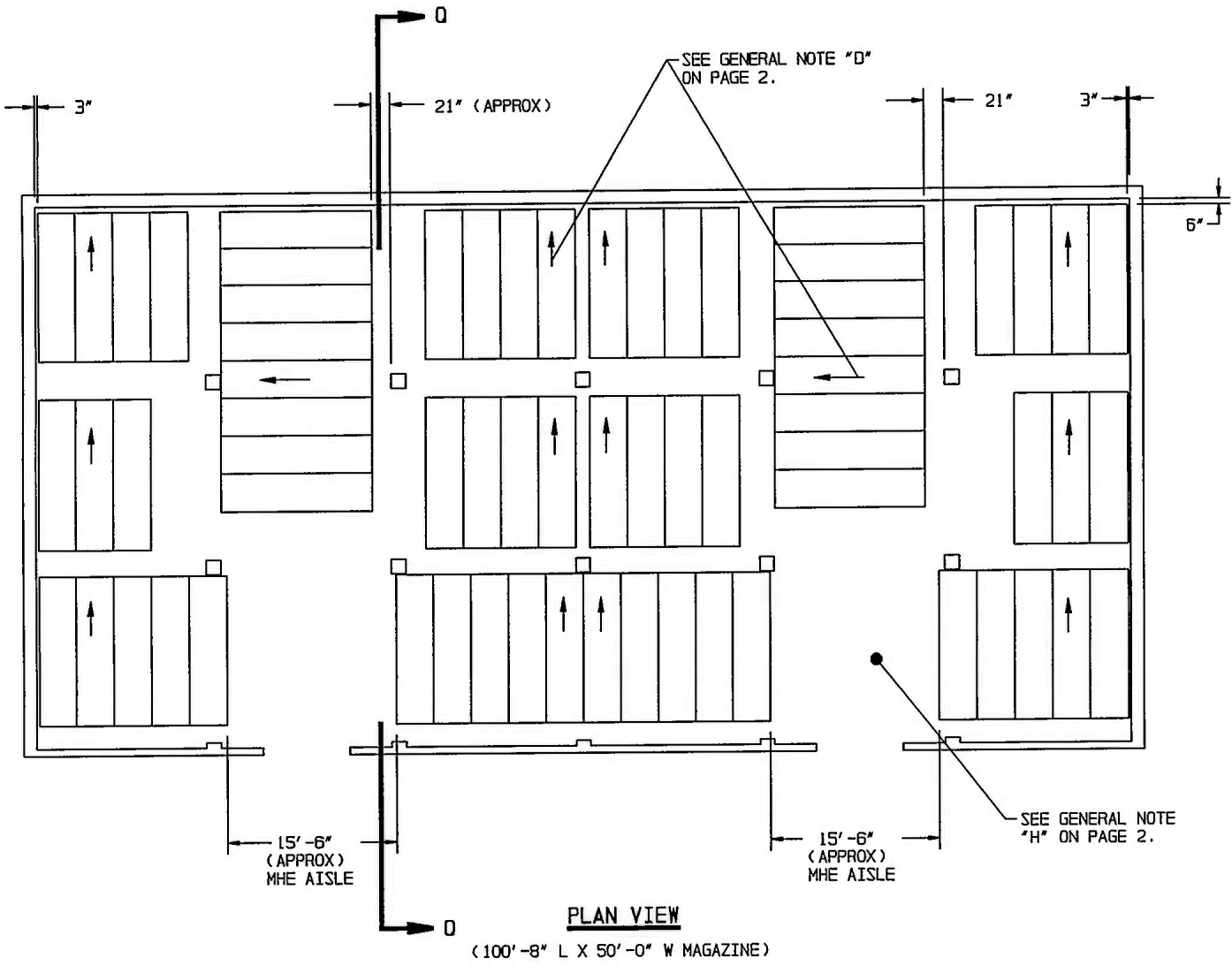

STORAGE IN 100'-8" L X 50'-0" W MAGAZINE

<u>ITEM</u>	<u>QUANTITY</u>
CONTAINER - - - - -	- - - 264

SEE GENERAL NOTE "D" ON PAGE 2.

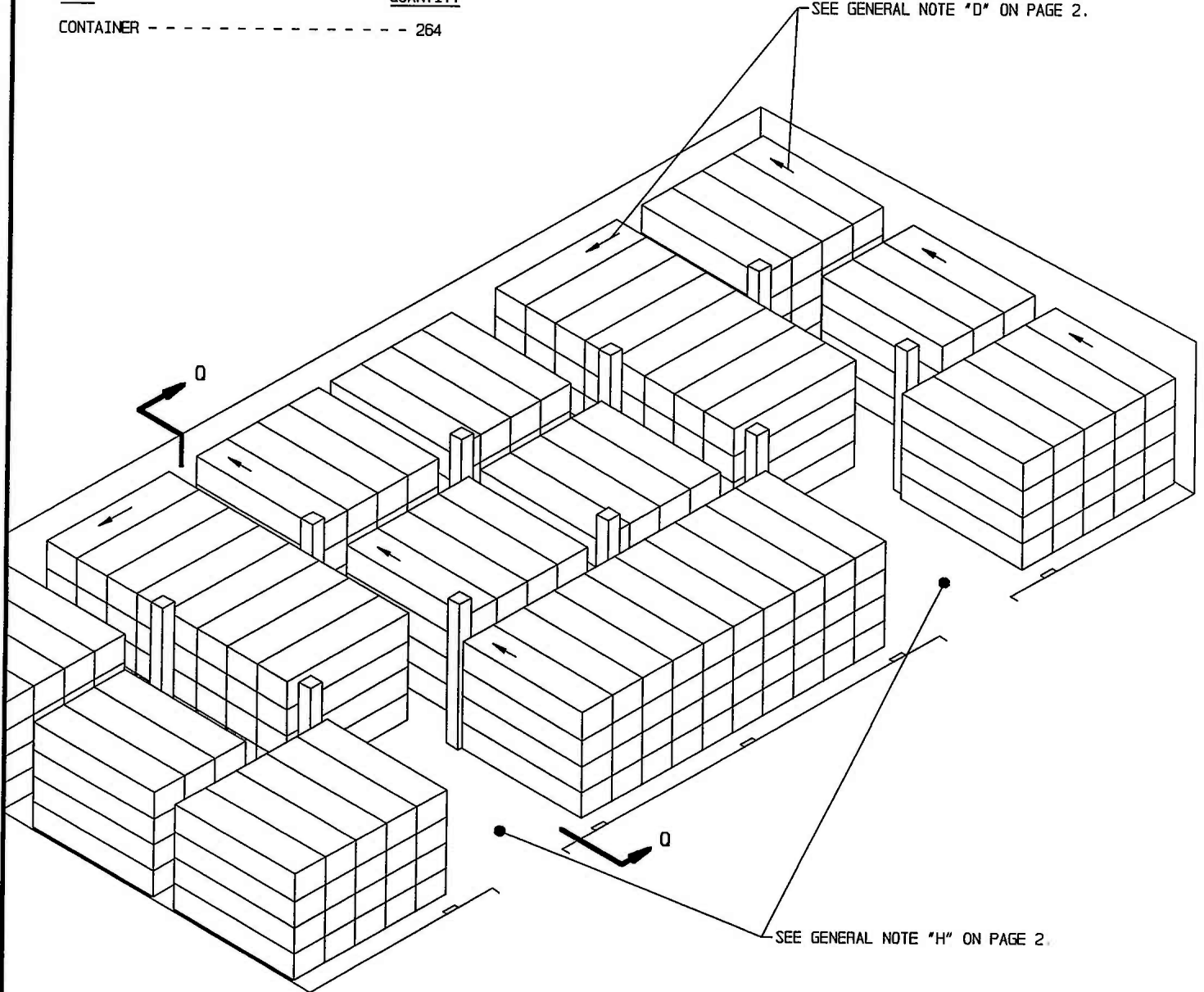

ISOMETRIC VIEW

(100'-8" L X 50'-0" W MAGAZINE)

FOR "GENERAL NOTES" AND "MATERIAL SPECIFICATIONS", SEE PAGE 2.

BILL OF MATERIAL PER CONTAINER STACK					
NO OF CNTRS HIGH	1" X 4" LUMBER		4" X 4" LUMBER		NAILS 6d (2")
	LINEAR FEET	BOARD FEET	LINEAR FEET	BOARD FEET	
FOUR	20.75	6.92	20.75	27.66	24

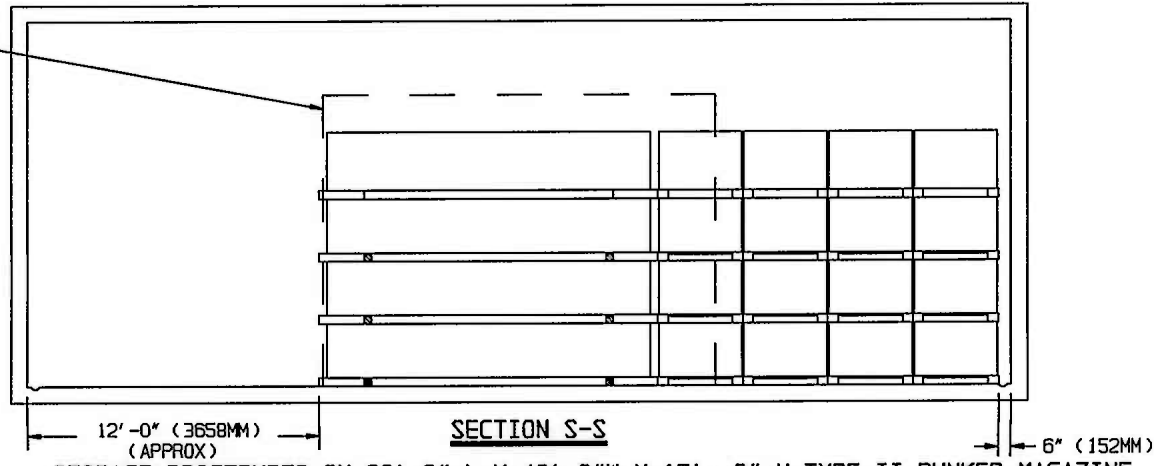
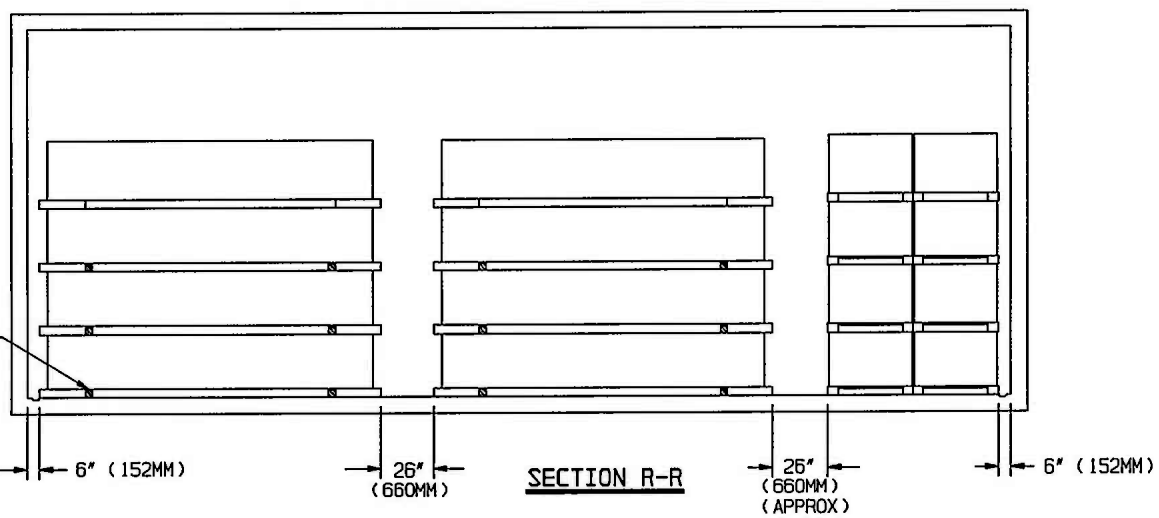
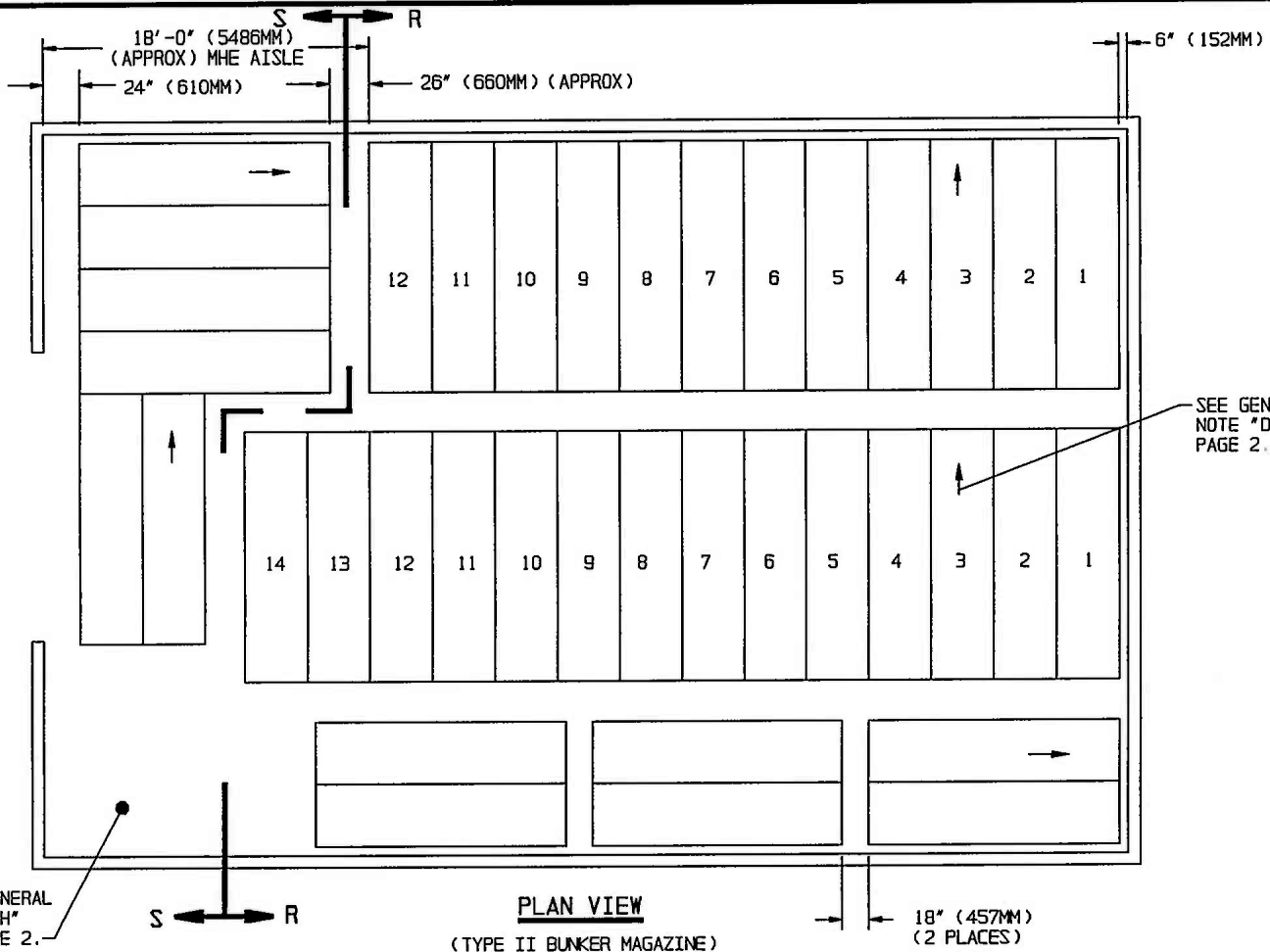

STORAGE PROCEDURES IN 60'-0" L X 40'-0" W X 15'-0" H TYPE II BUNKER MAGAZINE

STORAGE IN TYPE II BUNKER MAGAZINE

<u>ITEM</u>	<u>QUANTITY</u>
CONTAINER - - - - -	152

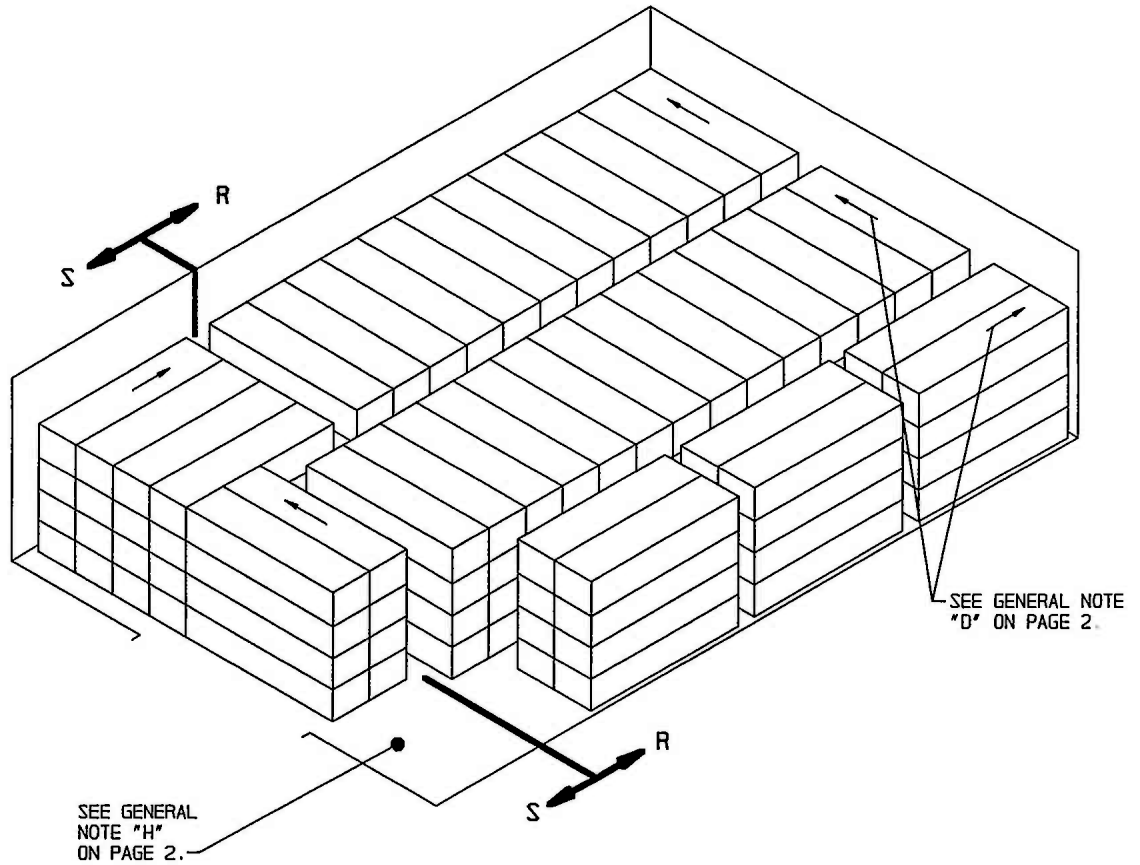

ISOMETRIC VIEW
(TYPE II BUNKER MAGAZINE)

BILL OF MATERIAL PER CONTAINER STACK					
NO. OF CNTRS HIGH	1" X 4" LUMBER		4" X 4" LUMBER		NAILS
	LINEAR FEET	BOARD FEET	LINEAR FEET	BOARD FEET	6d (2")
FOUR	20.75	6.92	20.75	27.66	24

FOR "GENERAL NOTES" AND "MATERIAL SPECIFICATIONS", SEE PAGE 2.

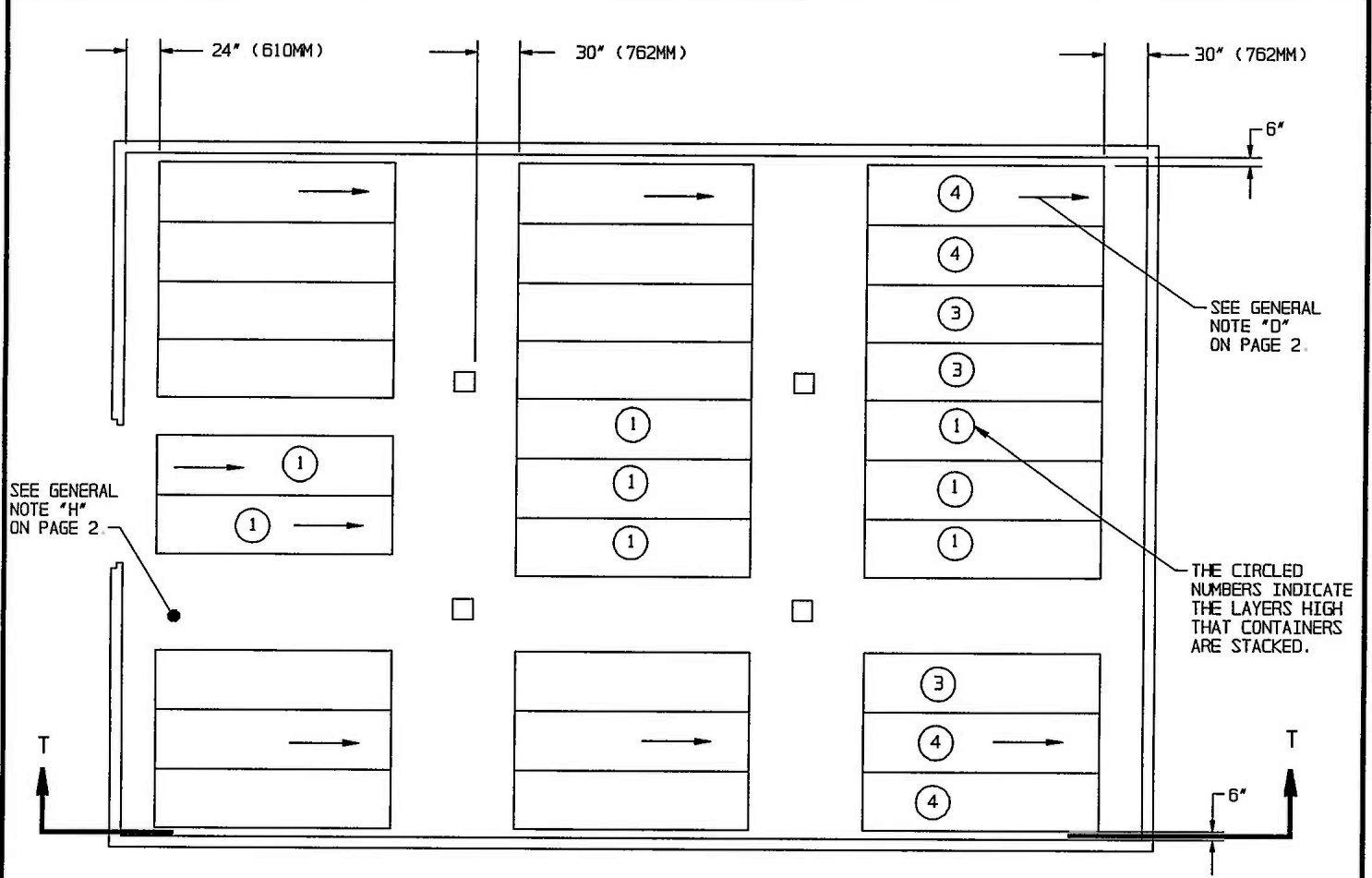

SEE GENERAL NOTE "H" ON PAGE 2.

SEE GENERAL NOTE "D" ON PAGE 2.

THE CIRCLED NUMBERS INDICATE THE LAYERS HIGH THAT CONTAINERS ARE STACKED.

PLAN VIEW
(TYPE III BUNKER MAGAZINE)

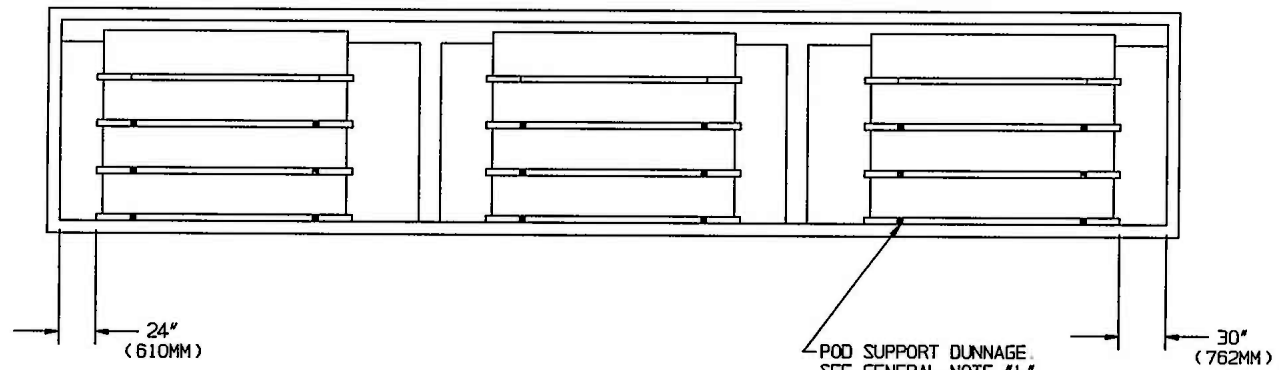

SECTION T-T

POD SUPPORT DUNNAGE. SEE GENERAL NOTE "L" ON PAGE 2 AND DETAIL ON PAGE 3.

STORAGE IN TYPE III BUNKER MAGAZINE

ITEM

QUANTITY

CONTAINER - - - - - 83

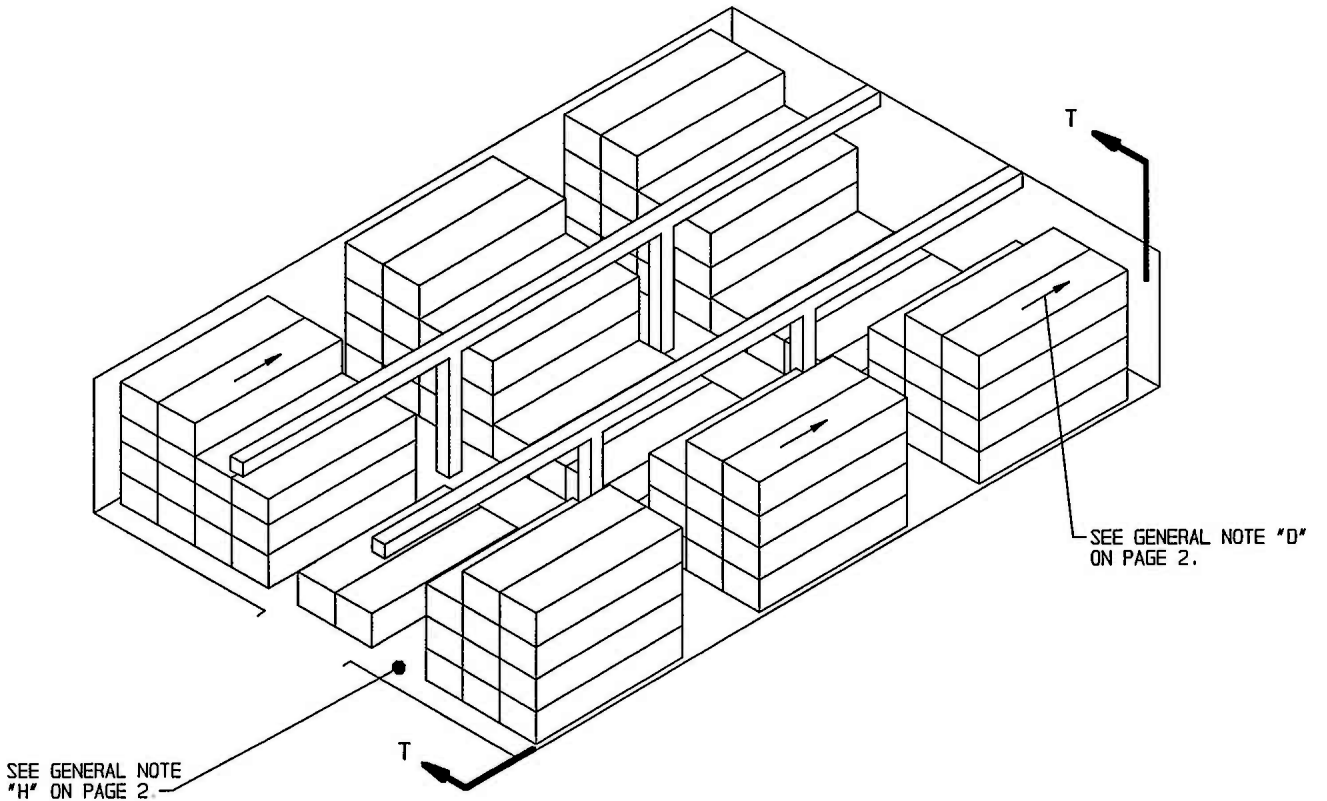

ISOMETRIC VIEW
(TYPE III BUNKER MAGAZINE)

FOR "GENERAL NOTES" AND "MATERIAL SPECIFICATIONS", SEE PAGE 2.

BILL OF MATERIAL PER CONTAINER STACK					
NO. OF CNTRS HIGH	1" X 4" LUMBER		4" X 4" LUMBER		NAILS
	LINEAR FEET	BOARD FEET	LINEAR FEET	BOARD FEET	6d (2")
ONE	- - -	- - -	- - -	- - -	- - -
THREE	13.83	4.61	13.83	18.44	16
FOUR	20.75	6.92	20.75	27.86	24

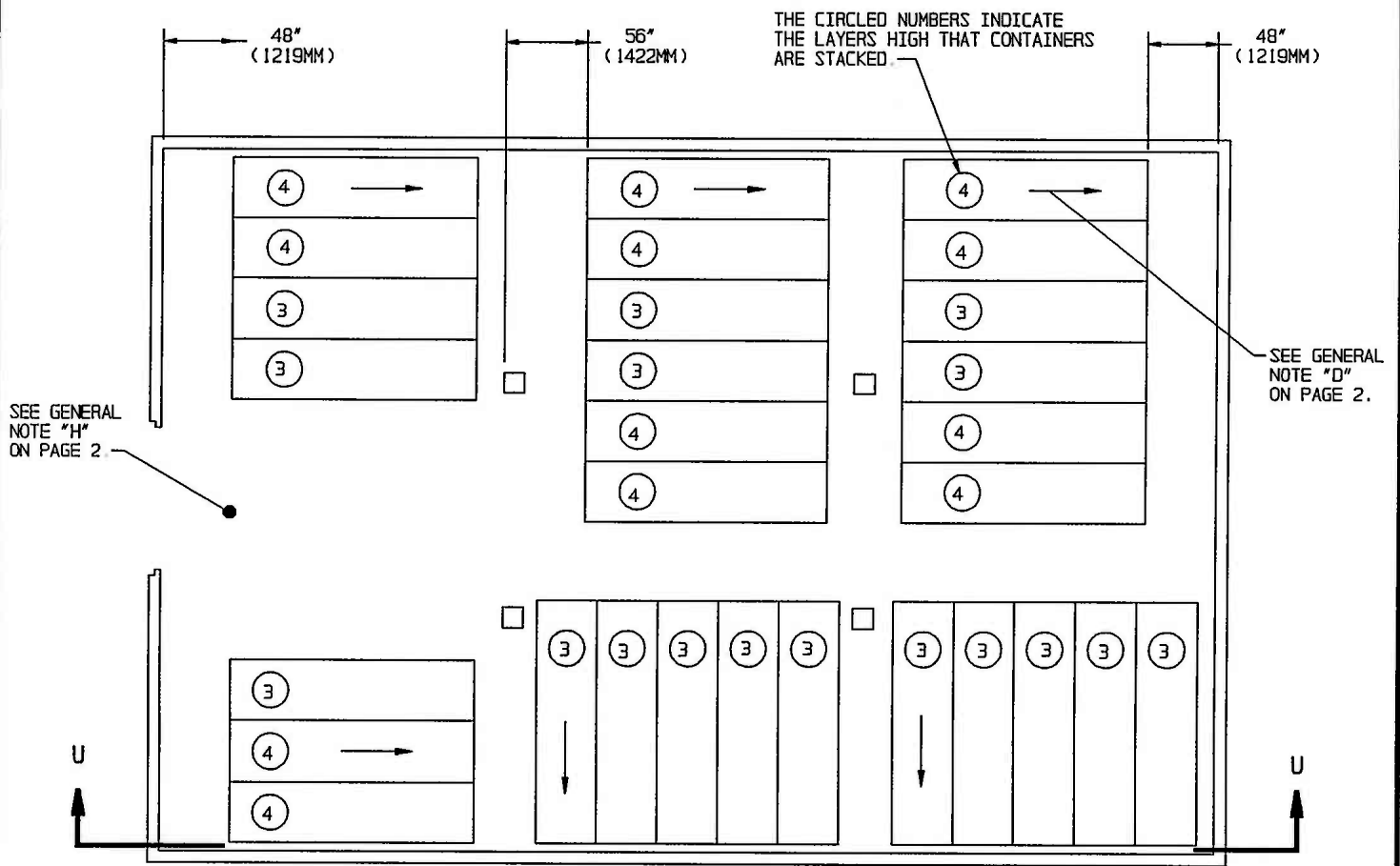

PLAN VIEW
(TYPE III BUNKER MAGAZINE)

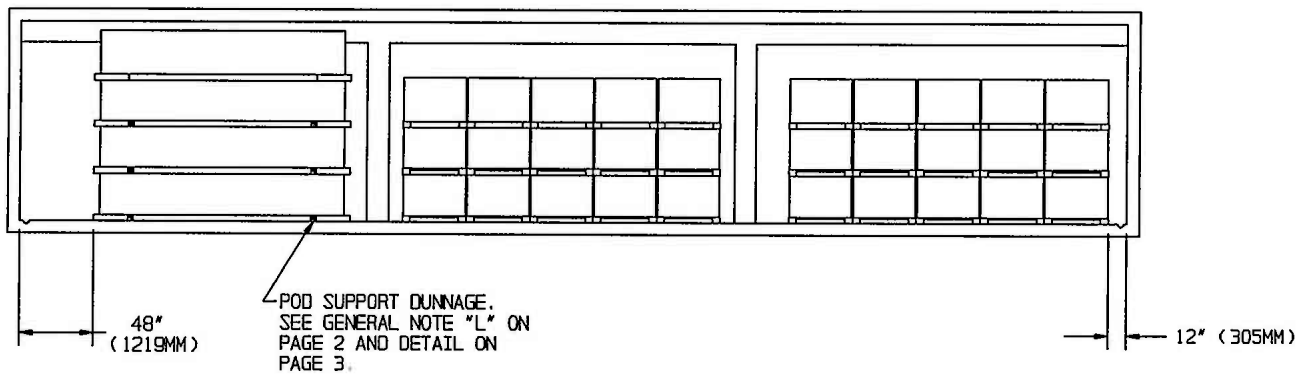

SECTION U-U

STORAGE IN TYPE III BUNKER MAGAZINE

ITEM QUANTITY
CONTAINER - - - - - 99

SEE GENERAL NOTE "D"
ON PAGE 2.

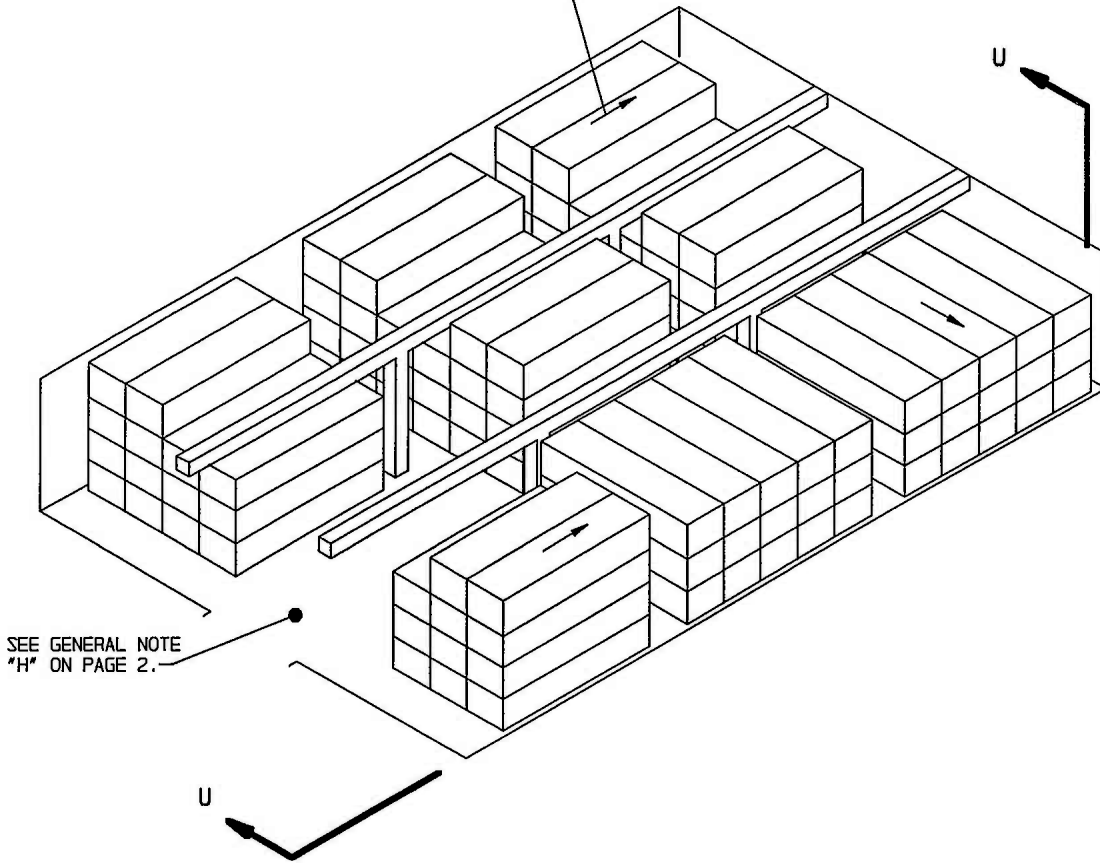

ISOMETRIC VIEW
(TYPE III BUNKER MAGAZINE)

FOR "GENERAL NOTES" AND "MATERIAL SPECIFICATIONS", SEE PAGE 2.

BILL OF MATERIAL PER CONTAINER STACK

NO. OF CNTRS HIGH	1" X 4" LUMBER		4" X 4" LUMBER		NAILS
	LINEAR FEET	BOARD FEET	LINEAR FEET	BOARD FEET	6d (2")
THREE	13.83	4.61	13.83	18.44	16
FOUR	20.75	6.92	20.75	27.86	24

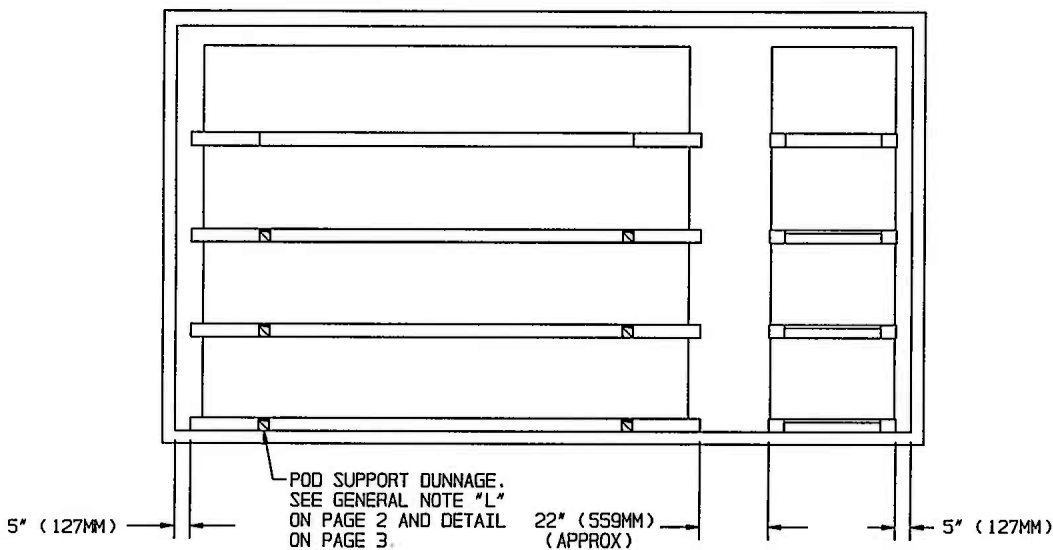
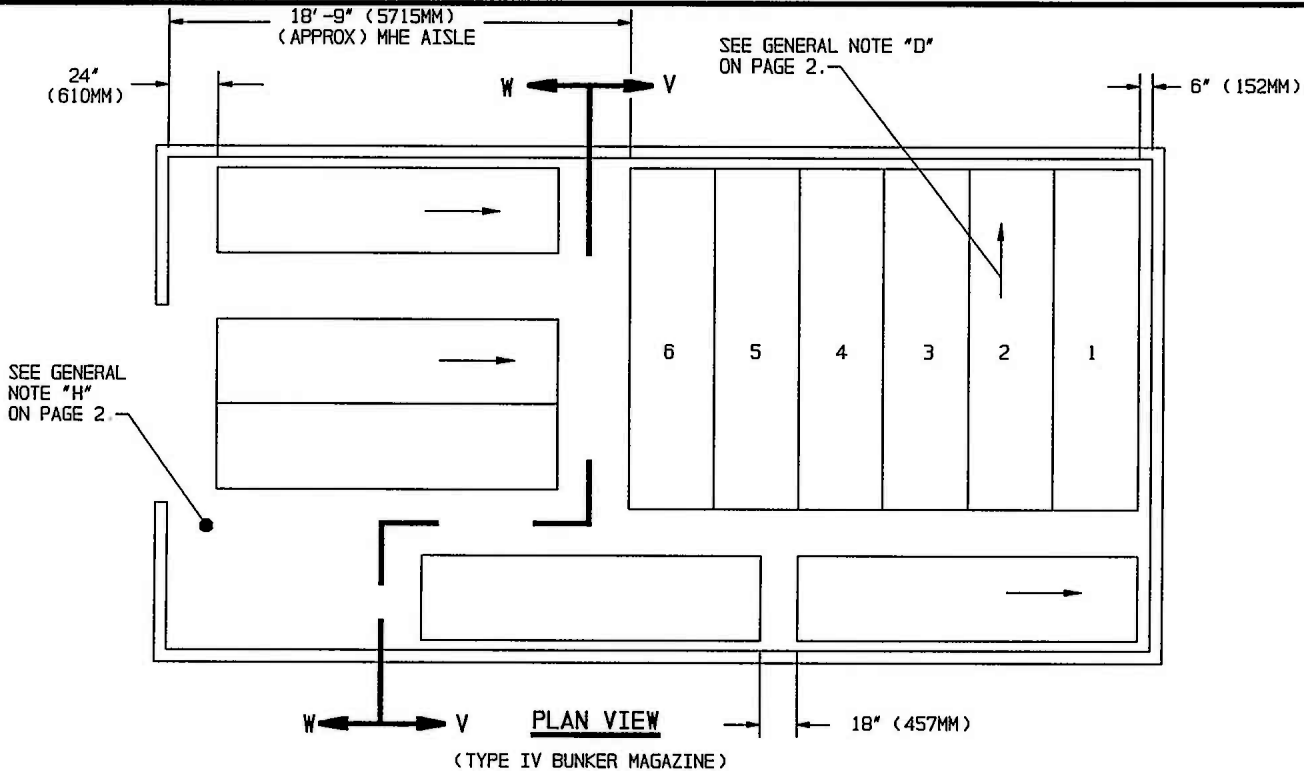

SECTION V-V

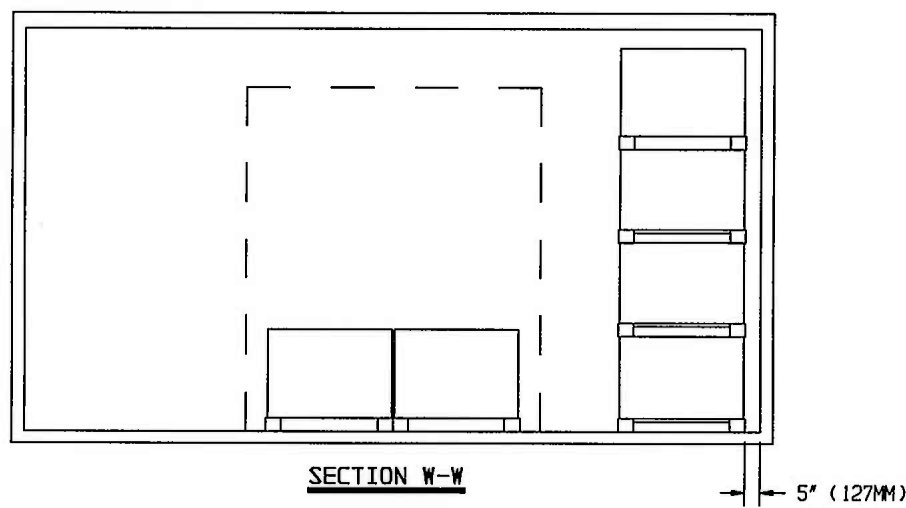

SECTION W-W

STORAGE IN TYPE IV BUNKER MAGAZINE

ITEM

QUANTITY

CONTAINER ----- 38

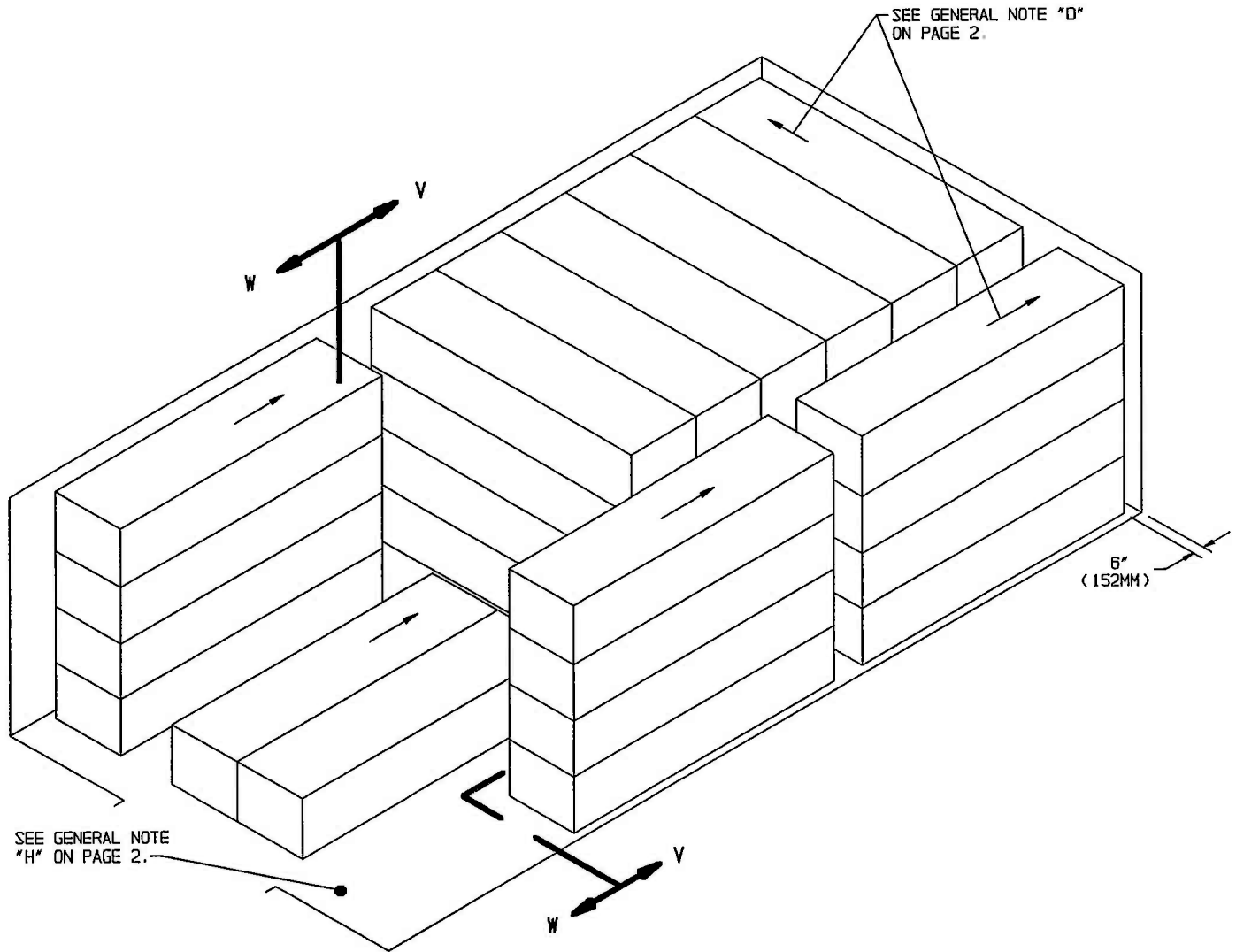

ISOMETRIC VIEW

(TYPE IV BUNKER MAGAZINE)

BILL OF MATERIAL PER CONTAINER STACK					
NO OF CNTRS HIGH	1" X 4" LUMBER		4" X 4" LUMBER		NAILS 6d (2")
	LINEAR FEET	BOARD FEET	LINEAR FEET	BOARD FEET	
ONE	---	---	---	---	---
THREE	13.83	4.61	13.83	18.44	16
FOUR	20.75	6.92	20.72	27.86	24

FOR "GENERAL NOTES" AND "MATERIAL SPECIFICATIONS", SEE PAGE 2.

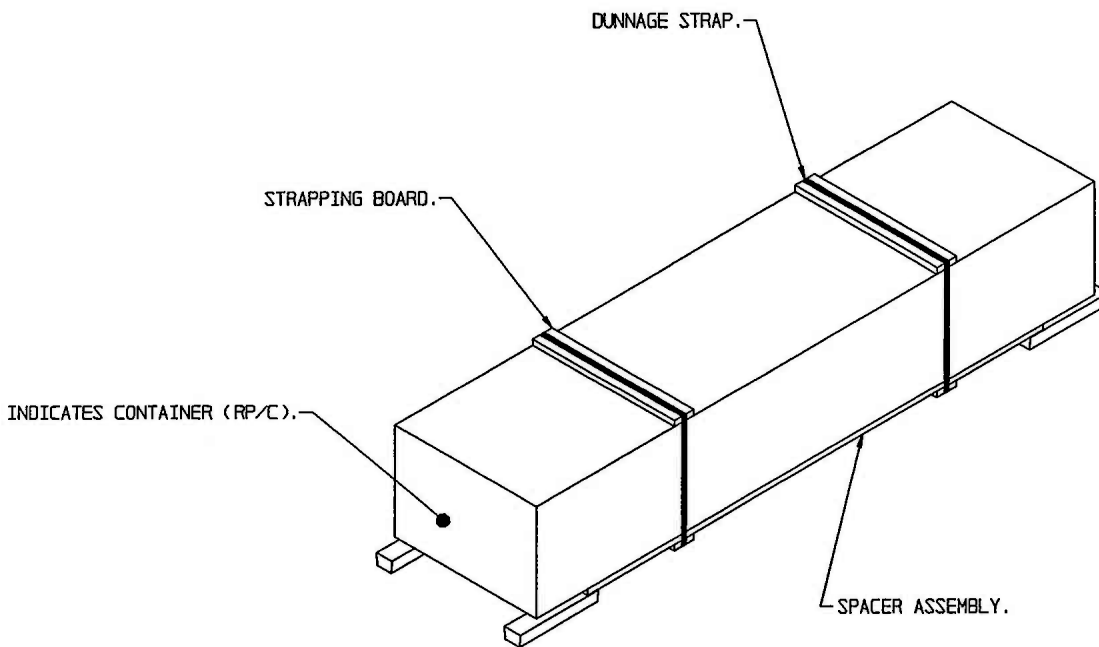

FIGURE 1

THIS VIEW DEPICTS AN UPPER LAYER CONTAINER WITH DUNNAGE/DUNNAGE ASSEMBLIES ATTACHED, AS REMOVED FROM A BOX CAR LOAD. STRAPPING BOARDS AND SPACER ASSEMBLY MAY REMAIN WITH CONTAINER DURING STORAGE. SEE SPECIAL NOTES 1 AND 2 ON PAGE 31.

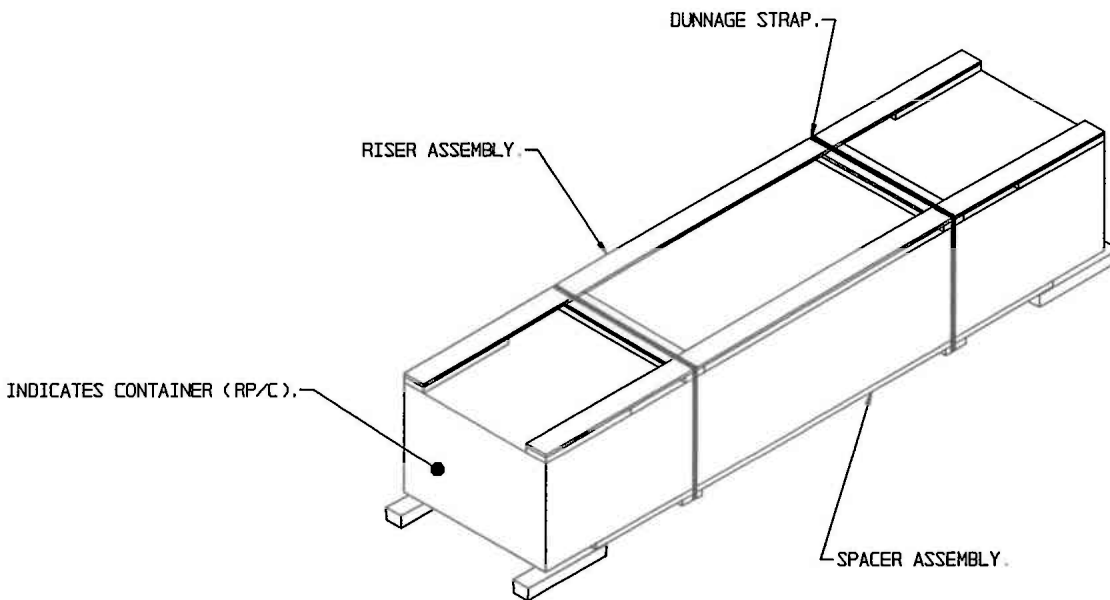
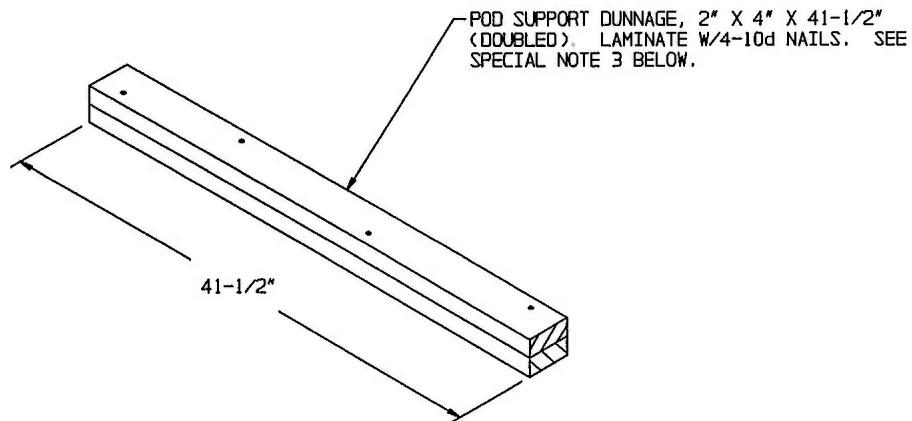

FIGURE 2

THIS VIEW DEPICTS A LOWER LAYER CONTAINER WITH DUNNAGE ASSEMBLIES ATTACHED, AS REMOVED FROM A BOX CAR LOAD. REMOVE BOTH DUNNAGE ASSEMBLIES BEFORE STORING CONTAINER UNLESS THE CONTAINER IS TO BE STORED IN THE TOP LAYER OF A STACK.



ALTERNATIVE POD SUPPORT ASSEMBLY

SPECIAL NOTES:

1. TWO (2) POD SUPPORT ASSEMBLIES ARE REQUIRED UNDER THE FRAME OF EACH FIRST-LAYER CONTAINER WHICH HAS ONE OR MORE CONTAINERS ON TOP. WHEN THE FIRST-LAYER CONTAINER HAS A SPACER ASSEMBLY ATTACHED, AS SHOWN IN THE FIGURE 1 VIEW ON PAGE 30, THE POD SUPPORT DUNNAGE WILL CONSIST OF LAMINATED 2" X 4" X 41-1/2" LONG PIECES IN LIEU OF THE LAMINATED 1" X 4" AND 4" X 4" X 41-1/2" LONG POD SUPPORT DUNNAGE SHOWN WITHIN THIS DOCUMENT. SEE THE "ALTERNATIVE POD SUPPORT ASSEMBLY" DETAIL ABOVE.
2. EACH UPPER LAYER ROCKET POD/CONTAINER WHICH HAS A SPACER ASSEMBLY ATTACHED, EXCEPT FOR THE VERY TOP CONTAINER IN A STACK, WILL HAVE THE LAMINATED 2" X 4" POD SUPPORT ASSEMBLIES POSITIONED UNDER IT AT EACH INWARD END OF THE CONTAINER SKIDS. EACH UPPER LAYER ROCKET POD/CONTAINER NOT HAVING A SPACER ASSEMBLY ATTACHED, EXCEPT FOR THE VERY TOP ONE IN A STACK, WILL HAVE THE LAMINATED 1" X 4" AND 4" X 4" POD SUPPORT DUNNAGE POSITIONED UNDER IT AS SHOWN WITHIN THE STORAGE VIEWS HEREIN.
3. FOR STABILITY PURPOSES, IT IS DESIRED THAT THE SKIDS OF A LOWER CONTAINER SUPPORT A PORTION OF THE WEIGHT OF THE CONTAINERS ABOVE. THE THICKNESS OF THE ALTERNATIVE SUPPORT ASSEMBLY SHOULD BE ADJUSTED AS NECESSARY TO PROVIDE THE PROPER SUPPORT BUT STILL MAINTAIN CONTACT BETWEEN THE METAL BOTTOM OF THE UPPER CONTAINER SKIDS AND THE TOP FRAME OF THE LOWER CONTAINER OR THE MAGAZINE FLOOR, AS APPLICABLE, TO PROVIDE PROPER ELECTRICAL CONDUCTIVITY. THE THICKNESS OF THE ALTERNATIVE SUPPORT ASSEMBLY MAY BE REDUCED BY SUBSTITUTING A COMBINATION OF 1" X 4" X 41-1/2" LONG LUMBER AND VARIOUS THICKNESSES OF 3-1/2" WIDE BY 41-1/2" LONG PLYWOOD FOR ONE THICKNESS OF THE 2" X 4" MATERIAL. THE THICKNESS MAY BE INCREASED BY ADDING A 1/4" OR THICKER PLYWOOD PIECE.

