

Jan 4/12

DATE 4/05/2006

APPENDIX 9

LOADING AND BRACING PROCEDURES FOR AMMUNITION LOADED ON CONTAINER ROLL IN/OUT PLATFORM (CROP)

HELLFIRE MISSILES PALLETIZED ON WOODEN PALLETS

INDEX

<u>ITEM</u>	<u>PAGE(S)</u>
TYPICAL LOADING PROCEDURES - - - - -	2
GENERAL NOTES - - - - -	3
PALLET UNIT DETAIL - - - - -	4
DETAILS - - - - -	4

NOTICE: THIS APPENDIX CANNOT STAND ALONE BUT MUST BE USED IN CONJUNCTION WITH THE BASIC CROP OUTLOADING PROCEDURES DRAWING 19-48-4906-CA17Q7.

- LOADING AND BRACING SPECIFICATIONS SET FORTH WITHIN THIS DRAWING ARE APPLICABLE TO LOADS THAT ARE TO BE SHIPPED BY TRAILER/CONTAINER-ON-FLATCAR (T/COFC) RAIL CARRIER SERVICE. THESE SPECIFICATIONS MAY ALSO BE USED FOR LOADS THAT ARE TO BE MOVED BY MOTOR OR WATER CARRIERS.

U.S. ARMY MATERIEL COMMAND DRAWING

APPROVED, U.S. ARMY
FIELD SUPPORT COMMAND

CAUTION: VERIFY PRIOR TO USE AT WWW.DAC.ARMY.MIL THAT THIS IS THE MOST CURRENT VERSION OF THIS DOCUMENT. THIS IS PAGE 1 OF 4.

DO NOT SCALE

MARCH 2006

Rud Aselt

ENGINEER OR TECHNICIAN	BASIC REV.	LAURA A. FIEFFER
---------------------------	---------------	------------------

APPROVED BY ORDER OF COMMANDING GENERAL,
U.S. ARMY MATERIEL COMMAND

TRANSPORTATION ENGINEERING DIVISION	<i>Laura A. Fieffer</i>	TESTED
---	-------------------------	--------

Charles P. Spoo

VALIDATION ENGINEERING DIVISION	<i>Gregory W. Lee</i>	TESTED
---------------------------------------	-----------------------	--------

U.S. ARMY DEFENSE AMMUNITION CENTER

ENGINEERING DIRECTORATE	<i>Robert L. Chalk</i>	TESTED
----------------------------	------------------------	--------

CLASS	DIVISION	DRAWING	FILE
19	48	4906/ 9	CA17Q6

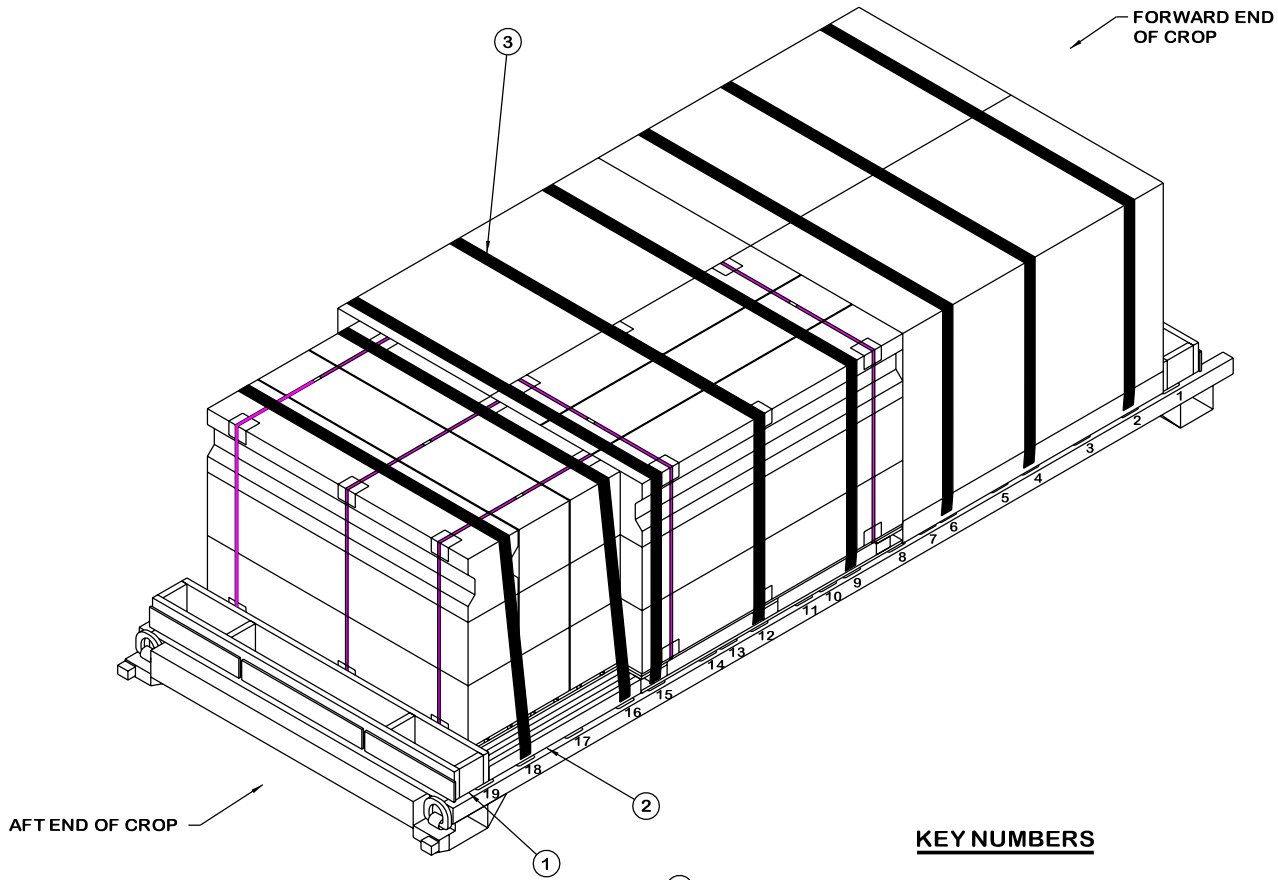

ISOMETRIC VIEW

KEY NUMBERS

- ① END FILLER ASSEMBLY (1 REQD). SEE DETAIL ON PAGE 4. CENTER AGAINST CROP END GATE AND, AFTER THE PALLET UNITS ARE LOADED, NAIL W/2-12d NAILS THRU THE SLOTS IN THE AFT CROP END GATE OR THRU THE HOLES IN THE FORWARD CROP END GATE INTO THE END FILLER ASSEMBLY, LEAVING THE NAIL HEADS PROTRUDING THRU THE SLOTS TO PROVIDE LATERAL RESTRAINT.
- ② SIDE BLOCKING, 2" X 4" X 44-1/4" (QUADRUPLD) (2 REQD). LAMINATE THE SECOND PIECE TO THE FIRST W/4-10d NAILS. LAMINATE EACH ADDITIONAL PIECE IN A LIKE MANNER. POSITION AGAINST THE CROSSWISE PALLET UNIT ON BOTH SIDES OF THE CROP AS SHOWN. AFTER THE HOLD-DOWN STRAPS ARE INSTALLED, NAIL THROUGH THE STRAP ATTACHMENT SLOTS OF EACH HOLD-DOWN STRAP INTO THE SIDE BLOCKING W/1-10d NAIL PARTIALLY DRIVEN AND BENT OVER SIDE OF HOOK.
- ③ HOLD-DOWN STRAP, 3-INCH WIDE WEB STRAP TIEDOWN ASSEMBLY FOR CROP (8 REQD). INSTALL EACH HOLD-DOWN STRAP TO EXTEND FROM THE DESIGNATED TIEDOWN ANCHOR ON ONE SIDE OF CROP, OVER THE TOP OF THE PALLET UNITS, TO THE CORRESPONDING TIEDOWN ANCHOR ON THE OPPOSITE SIDE OF THE CROP. ALIGN SCUFF SLEEVES OVER ALL SHARP EDGES AND FIRMLY TENSION STRAP. SEE GENERAL NOTES "F" AND "G" ON PAGE 3.

GENERAL NOTES

- A. THIS APPENDIX CANNOT STAND ALONE BUT MUST BE USED IN CONJUNCTION WITH THE BASIC LOADING PROCEDURES DRAWING 19-48-4906-CA17Q7. TO PRODUCE AN APPROVED LOAD, ALL PERTINENT PROCEDURES, SPECIFICATIONS AND CRITERIA SET FORTH WITHIN THE BASIC DRAWING WILL APPLY TO THE PROCEDURES DELINEATED IN THIS APPENDIX. ANY EXCEPTIONS TO THE BASIC PROCEDURES ARE SPECIFIED IN THIS APPENDIX.
- B. THE OUTLOADING PROCEDURES DEPICTED IN THIS DRAWING ARE APPLICABLE TO LOADS OF FIVE PALLET UNITS. SEE PAGE 4 FOR DETAIL OF THE TYPICAL PALLET UNIT. AN M3A1 (HYUNDAI) CROP IS SHOWN AS TYPICAL. OTHER MANUFACTURER'S CROPS CAN BE USED FOR THE LOAD SHOWN ON PAGE 2. ACTUAL CROP CONFIGURATION WILL DETERMINE WHETHER THE LOADING STARTS AT THE AFT OR THE FORWARD END OF THE CROP. THE END FILLER ASSEMBLIES MUST BE RESTRAINED FROM MOVING IN BOTH THE LATERAL AND VERTICAL DIRECTIONS. THIS IS ACCOMPLISHED IN THE LOAD SHOWN ON PAGE 2 WITH HOLD DOWN PIECES AND RETAINING NAILS. IF THE CONFIGURATION OF A CROP IS SUCH THAT VERTICAL OR LATERAL RESTRAINT CANNOT BE PROVIDED, ADDITIONAL RESTRAINT METHODS SUCH AS 2" WIDE WEB STRAP TIE-DOWN ASSEMBLIES MUST BE INSTALLED.
- C. THE LOADING PROCEDURES DEPICTED HEREIN MAY BE USED FOR OUTLOADING PALLET UNITS WITH DIMENSIONS OTHER THAN WHAT IS SHOWN ON PAGE 4, PROVIDED THE OVERALL PALLET UNIT DIMENSIONS RESULT IN A LOAD THAT IS CONTAINED WITHIN AN ENVELOPE OF 211" L X 89" W X 73-1/2" H.
- D. DIMENSIONS, CUBE AND WEIGHT OF THE PALLET UNITS WILL VARY SLIGHTLY DEPENDING UPON THE ACTUAL DIMENSIONS OF THE BOXES AND THE WEIGHT OF THE SPECIFIC ITEM BEING UNITIZED.
- E. DIMENSIONS GIVEN FOR DUNNAGE ASSEMBLIES WILL BE FIELD CHECKED PRIOR TO THEIR ASSEMBLY. PALLET UNITS MUST FIT SNUGLY AGAINST THE DUNNAGE ASSEMBLIES. THIS GUIDANCE MUST BE APPLIED PRIOR TO BEGINNING AN OUTLOADING OPERATION. ALSO, DUE TO VARIATION OF PALLET UNIT DIMENSIONS, ADJUSTMENTS MAY BE REQUIRED AS TO THE LOCATION OF CERTAIN PIECES ON DUNNAGE ASSEMBLIES.
- F. ALL WEB STRAP TIEDOWN ASSEMBLIES MUST HAVE THE EXCESS LENGTH OF THE STRAP SECURED. ROLL UP AND BUNDLE THE EXCESS LENGTH OF WEB STRAP, SECURING WITH CABLE TIES. SEE THE "STRAP END SECUREMENT" DETAIL AND GENERAL NOTE "K.12" IN THE BASIC PROCEDURE DRAWING 19-48-4906-CA17Q7.
- G. UNUSED WEB STRAP TIEDOWN ASSEMBLIES MUST BE SECURED AS DELINEATED IN GENERAL NOTE "K.13" IN THE BASIC PROCEDURE DRAWING 19-48-4906-CA17Q7.
- H. CONVERSION TO METRIC EQUIVALENTS: DIMENSIONS WITHIN THIS DOCUMENT ARE EXPRESSED IN INCHES, AND WEIGHTS ARE EXPRESSED IN POUNDS. WHEN NECESSARY, THE METRIC EQUIVALENTS MAY BE COMPUTED ON THE BASIS OF ONE INCH EQUALS 25.4MM AND ONE POUND EQUALS 0.454 KG.

BILL OF MATERIAL		
LUMBER	LINEAR FEET	BOARD FEET
2" X 3"	4	2
2" X 4"	30	20
2" X 8"	32	43
NAILS	NO. REQD	POUNDS
10d (3")	84	1-1/2
12d (3-1/4")	12	1/4

LOAD AS SHOWN

ITEM	QUANTITY	WEIGHT (APPROX)
PALLET UNIT	5	8,745 LBS
DUNNAGE		131 LBS
CROP		3,800 LBS
TOTAL WEIGHT		12,676 LBS (APPROX)

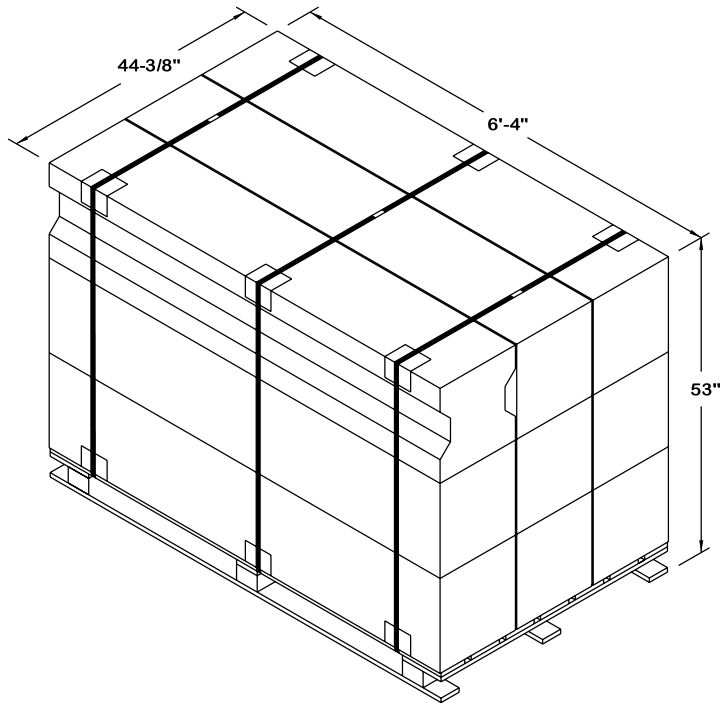

HELLFIRE PALLET UNIT DETAIL

SEE AMC 19-48-5250-GM20HF1 FOR DETAILS

9 CONTAINERS OF HELLFIRE MISSILES @ 185 LBS	-----	1,665 LBS (APPROX)
DUNNAGE	-----	4 LBS
PALLET	-----	80 LBS
<hr/>		
TOTAL WEIGHT	-----	1,749 LBS (APPROX)
CUBE	-----	103.4 CU FT (APPROX)

STRUT, 2" X 8" X 7"
(AFT) OR 7'-1/2" (REF)
(FORWARD) (4 REQD).

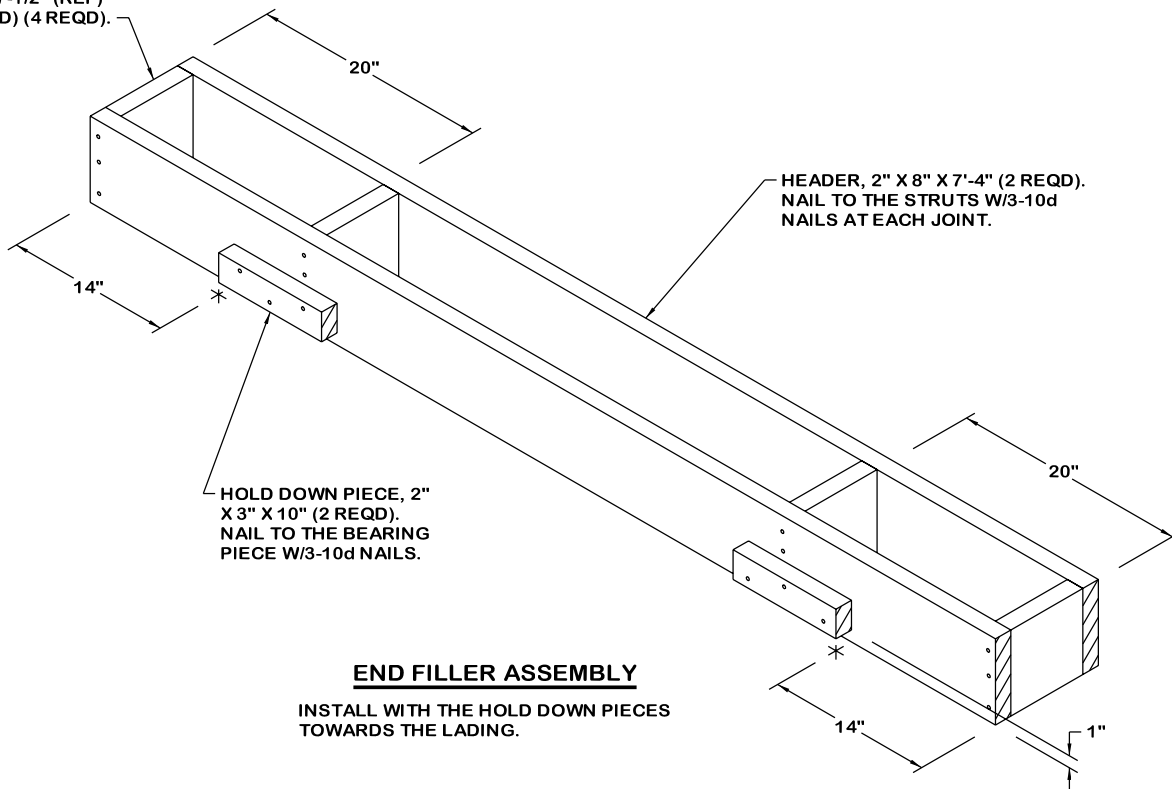

HEADER, 2" X 8" X 7'-4" (2 REQD).
NAIL TO THE STRUTS W/3-10d
NAILS AT EACH JOINT.

HOLD DOWN PIECE, 2"
X 3" X 10" (2 REQD).
NAIL TO THE BEARING
PIECE W/3-10d NAILS.

END FILLER ASSEMBLY

INSTALL WITH THE HOLD DOWN PIECES
TOWARDS THE LADING.