

*D L H*

DATE 12/19/01

# APPENDIX 50

## LOADING AND BRACING PROCEDURES FOR AMMUNITION LOADED ON CONTAINER ROLL IN/OUT PLATFORM (CROP)

**BOXED AMMUNITION PALLETIZED ON 35" X  
45-1/2" WOODEN PALLETS; TYPICAL PALLET  
UNIT SIZE 37-1/4" L X 47-3/4" W X 51-1/8" H  
(3,600 LBS MAXIMUM WEIGHT)**

### INDEX

<u>ITEM</u>	<u>PAGE(S)</u>
TYPICAL LOADING PROCEDURES - - - - -	2
GENERAL NOTES - - - - -	3
PALLET UNIT DETAIL - - - - -	4
DETAILS - - - - -	4, 5

**NOTICE: THIS APPENDIX CANNOT STAND ALONE BUT MUST BE USED IN CONJUNCTION WITH  
THE BASIC CROP OUTLOADING PROCEDURES DRAWING 19-48-4906-CA17Q7.**

- LOADING AND BRACING SPECIFICATIONS SET FORTH WITHIN THIS DRAWING ARE APPLICABLE TO LOADS THAT ARE TO BE SHIPPED BY TRAILER/CONTAINER-ON-FLATCAR (T/COFC) RAIL CARRIER SERVICE. THESE SPECIFICATIONS MAY ALSO BE USED FOR LOADS THAT ARE TO BE MOVED BY MOTOR OR WATER CARRIERS.

## U.S. ARMY MATERIEL COMMAND DRAWING

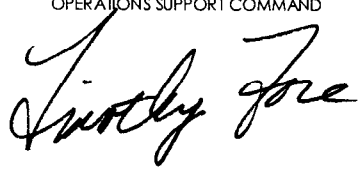
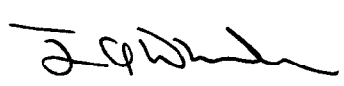
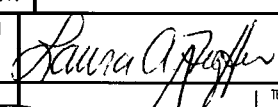
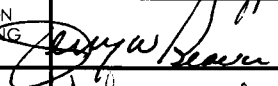
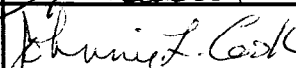
APPROVED, U.S. ARMY OPERATIONS SUPPORT COMMAND  	ENGINEER	BASIC	WALTER GORDON		DO NOT SCALE			
		REV.			WEBSITE: <a href="http://www.dac.army.mil">HTTP://WWW.DAC.ARMY.MIL</a>			
	TECHNICIAN	BASIC			DECEMBER 2000			
		REV.						
	DRAFTSMAN	BASIC						
		REV.						
APPROVED BY ORDER OF COMMANDING GENERAL, U.S. ARMY MATERIEL COMMAND  	TRANSPORTATION ENGINEERING DIVISION			TESTED	CLASS	DIVISION	DRAWING	FILE
	VALIDATION ENGINEERING DIVISION				19	48	4906/ 50	CA17Q7
	ENGINEERING DIRECTORATE							

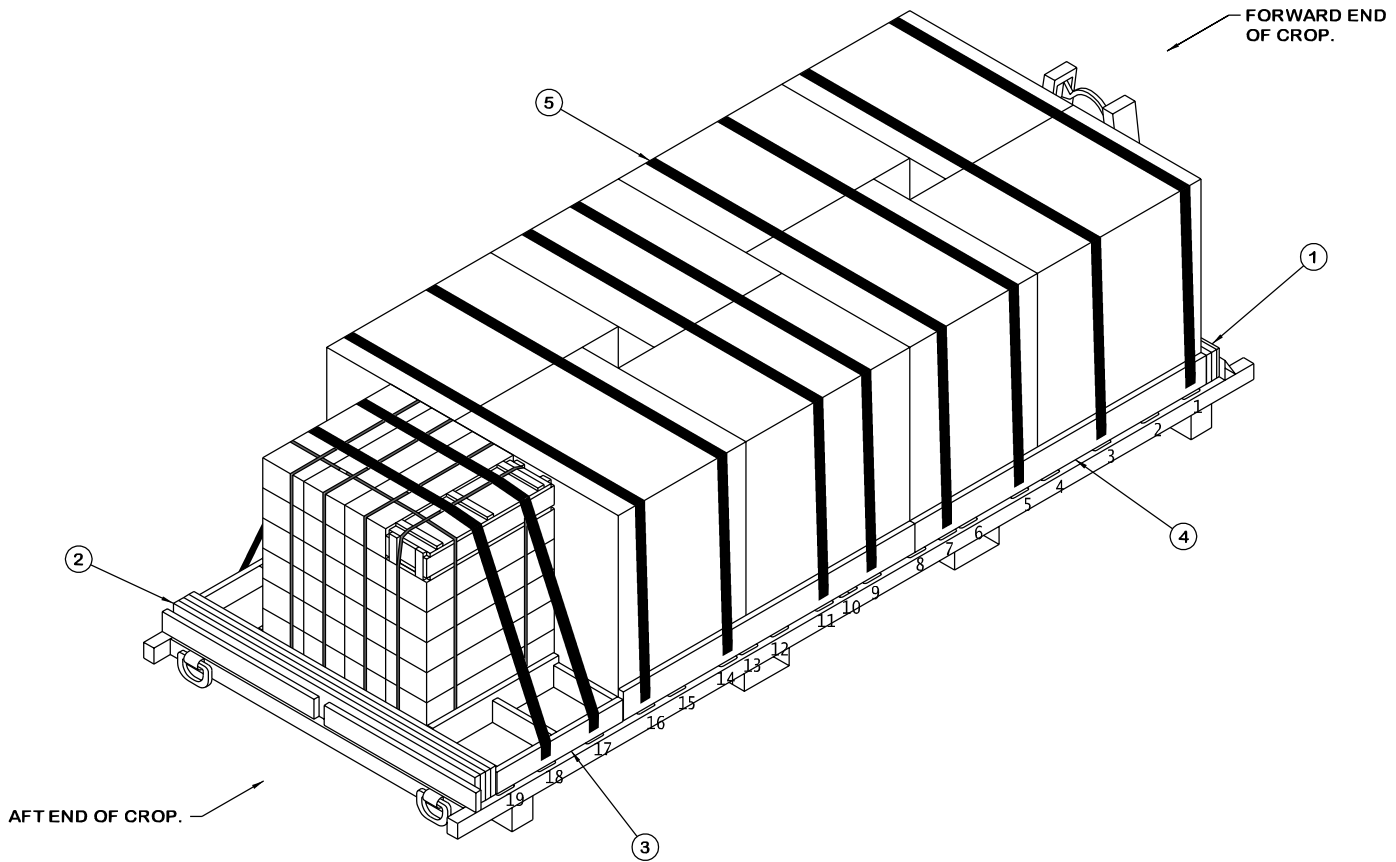

**ISOMETRIC VIEW**

**KEY NUMBERS**

- ① FORWARD FILLER ASSEMBLY (1 REQD). SEE THE DETAIL ON PAGE 5. CENTER AGAINST FORWARD CROP END GATE AND, AFTER THE PALLET UNITS ARE LOADED, NAIL W/2-12d NAILS THRU THE SLOTS IN THE FORWARD CROP END GATE INTO THE FORWARD FILLER ASSEMBLY, LEAVING THE NAIL HEADS PROTRUDING THRU THE SLOTS TO PROVIDE LATERAL RESTRAINT. SEE GENERAL NOTE "B" ON PAGE 3.
- ② AFT FILLER ASSEMBLY (1 REQD). SEE DETAIL ON PAGE 5. CENTER AGAINST AFT CROP END GATE AND, AFTER THE PALLET UNITS ARE LOADED, NAIL W/2-12d NAILS THRU UPPER CORNER OF OPENING IN AFT END GATES INTO THE AFT FILLER ASSEMBLY, WITH NAIL HEADS PROTRUDING AND BENT OVER VERTICAL TUBE OF END GATES TO PROVIDE LATERAL AND VERTICAL RESTRAINT. SEE GENERAL NOTE "B" ON PAGE 3.
- ③ SPACER ASSEMBLY (2 REQD). SEE THE DETAIL ON PAGE 4. INSTALL ONE ASSEMBLY ON EACH SIDE OF CROP ADJACENT TO THE AFT PALLET UNIT. NAIL THRU EACH SPACER ASSEMBLY W/2-10d NAILS INTO THE AFT FILLER ASSEMBLY. SEE GENERAL NOTE "G" ON PAGE 3.
- ④ SIDE FILL, 2" X 8" X 7'-1" (4 REQD). INSTALL TWO ON EACH SIDE OF THE CROP. SEE GENERAL NOTE "G" ON PAGE 3.
- ⑤ HOLD-DOWN STRAP, 3-INCH WIDE WEB STRAP TIEDOWN ASSEMBLY FOR CROP (10 REQD). INSTALL EACH HOLD-DOWN STRAP TO EXTEND FROM THE DESIGNATED TIEDOWN ANCHOR ON ONE SIDE OF CROP, OVER TOP OF PALLET UNITS, TO CORRESPONDING TIEDOWN ANCHOR ON OPPOSITE SIDE OF CROP. ALIGN SCUFF SLEEVES OVER ALL SHARP EDGES AND FIRMLY TENSION STRAP. SEE GENERAL NOTES "F" AND "H" ON PAGE 3.

**GENERAL NOTES**

- A. THIS APPENDIX CANNOT STAND ALONE BUT MUST BE USED IN CONJUNCTION WITH THE BASIC LOADING PROCEDURES DRAWING 19-48-4906-CA17Q7. TO PRODUCE AN APPROVED LOAD, ALL PERTINENT PROCEDURES, SPECIFICATIONS AND CRITERIA SET FORTH WITHIN THE BASIC DRAWING WILL APPLY TO THE PROCEDURES DELINEATED IN THIS APPENDIX. ANY EXCEPTIONS TO THE BASIC PROCEDURES ARE SPECIFIED IN THIS APPENDIX.
- B. THE OUTLOADING PROCEDURES DEPICTED IN THIS DRAWING ARE APPLICABLE TO LOADS OF NINE PALLET UNITS. SEE PAGE 4 FOR DETAIL OF THE TYPICAL PALLET UNIT. AN M3 (SUMMA) CROP IS SHOWN AS TYPICAL. OTHER MANUFACTURER'S CROPS CAN BE USED FOR THE LOAD SHOWN ON PAGE 2. THE AFT AND FORWARD END FILLER ASSEMBLIES OR PIECES MUST BE RESTRAINED FROM MOVING IN BOTH THE LATERAL AND VERTICAL DIRECTIONS. THIS IS ACCOMPLISHED IN THE LOAD SHOWN ON PAGE 2 WITH RETAINING NAILS AND HOLD DOWN PIECES (FORWARD FILLER ASSEMBLY) AND RETAINING NAILS (AFT FILLER ASSEMBLY). IF THE CONFIGURATION OF A CROP IS SUCH THAT VERTICAL OR LATERAL RESTRAINT CANNOT BE PROVIDED, ADDITIONAL RESTRAINT METHODS, TO INCLUDE HOLD DOWN PIECES, RETAINING NAILS, AND/OR 2" WIDE WEB STRAP TIEDOWN ASSEMBLIES MUST BE INSTALLED.
- C. THE LOADING PROCEDURES DEPICTED HEREIN MAY BE USED FOR OUTLOADING PALLET UNITS WITH DIMENSIONS OTHER THAN WHAT IS SHOWN ON PAGE 4, PROVIDED THE OVERALL PALLET UNIT DIMENSIONS RESULT IN A LOAD THAT IS CONTAINED WITHIN AN ENVELOPE OF 211" L X 89" W X 73-1/2" H.
- D. DIMENSIONS, CUBE AND WEIGHT OF THE PALLET UNITS WILL VARY SLIGHTLY DEPENDING UPON THE ACTUAL DIMENSIONS OF THE BOXES AND THE WEIGHT OF THE SPECIFIC ITEM BEING UNITIZED.
- E. DIMENSIONS GIVEN FOR DUNNAGE ASSEMBLIES WILL BE FIELD CHECKED PRIOR TO THEIR ASSEMBLY. PALLET UNITS MUST FIT SNUGLY AGAINST THE DUNNAGE ASSEMBLIES. THIS GUIDANCE MUST BE APPLIED PRIOR TO BEGINNING AN OUTLOADING OPERATION. ALSO, DUE TO VARIATION OF PALLET UNIT DIMENSIONS, ADJUSTMENTS MAY BE REQUIRED AS TO THE LOCATION OF CERTAIN PIECES ON DUNNAGE ASSEMBLIES.
- F. ALL WEB STRAP TIEDOWN ASSEMBLIES MUST HAVE THE EXCESS LENGTH OF THE STRAP SECURED. ROLL UP AND BUNDLE THE EXCESS LENGTH OF WEB STRAP, SECURING WITH CABLE TIES. SEE THE "STRAP END SECUREMENT" DETAIL AND GENERAL NOTE "K.12" IN THE BASIC PROCEDURE DRAWING 19-48-4906-CA17Q7.
- G. EACH END OF THE SIDE FILL AND SPACER ASSEMBLIES MUST BE SECURED BY NAILING A 10d NAIL THRU A 3" WEBSTRAP HOOK SLOT. SEE "STRAP HOOK DETAIL" AND GENERAL NOTE "G.2" IN THE BASIC PROCEDURES DRAWING 19-48-4906-CA17Q7.
- H. UNUSED WEB STRAP TIEDOWN ASSEMBLIES MUST BE SECURED AS DELINEATED IN GENERAL NOTE "K.13" IN THE BASIC PROCEDURE DRAWING 19-48-4906-CA17Q7.
- J. CONVERSION TO METRIC EQUIVALENTS: DIMENSIONS WITHIN THIS DOCUMENT ARE EXPRESSED IN INCHES, AND WEIGHTS ARE EXPRESSED IN POUNDS. WHEN NECESSARY, THE METRIC EQUIVALENTS MAY BE COMPUTED ON THE BASIS OF ONE INCH EQUALS 25.4MM AND ONE POUND EQUALS 0.454 KG.

BILL OF MATERIAL		
LUMBER	LINEAR FEET	BOARD FEET
1" X 8"	8	5
2" X 3" (ACTUAL)	2	1
2" X 6"	15	15
2" X 8"	79	105
NAILS	NO. REQD	POUNDS
6d (2")	8	NIL
10d (3")	90	1-1/2
12d (3-1/4")	4	NIL

**LOAD AS SHOWN**

ITEM	QUANTITY	WEIGHT (APPROX)
PALLET UNIT	9	26,568 LBS
DUNNAGE		253 LBS
CROP		3,800 LBS
TOTAL WEIGHT		30,621 LBS (APPROX)

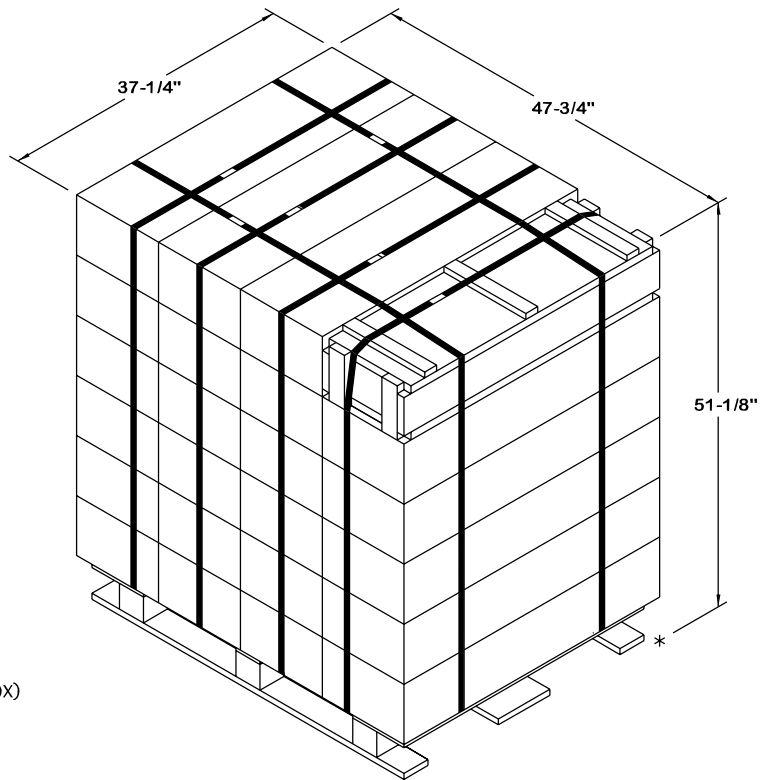

**TYPICAL PALLET UNIT DETAIL**

GROSS WEIGHT - - - - - 2,952 LBS (APPROX)  
 CUBE - - - - - 52.6 CUBIC FEET (APPROX)

BEARING PIECE, 2" X 8" X 36-3/4" (1 REQD). NAIL TO THE LATERAL PIECES W/3-10d NAILS AT EACH JOINT. NOTE: PLACE THIS SIDE OF ASSEMBLY AGAINST THE AFT PALLET UNIT.

LATERAL PIECE, 2" X 6" X 17-1/4" (3 REQD).

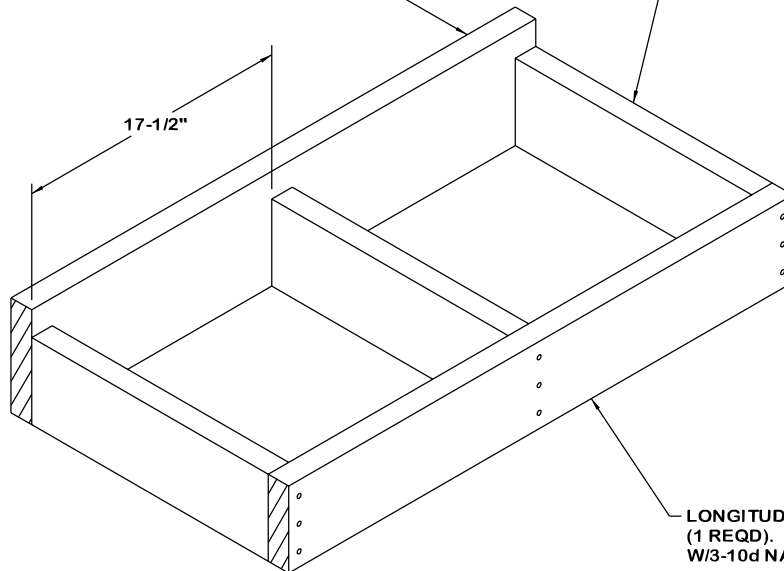

LONGITUDINAL PIECE, 2" X 6" X 36-3/4" (1 REQD). NAIL TO THE LATERAL PIECES W/3-10d NAILS AT EACH JOINT.

**SPACER ASSEMBLY**

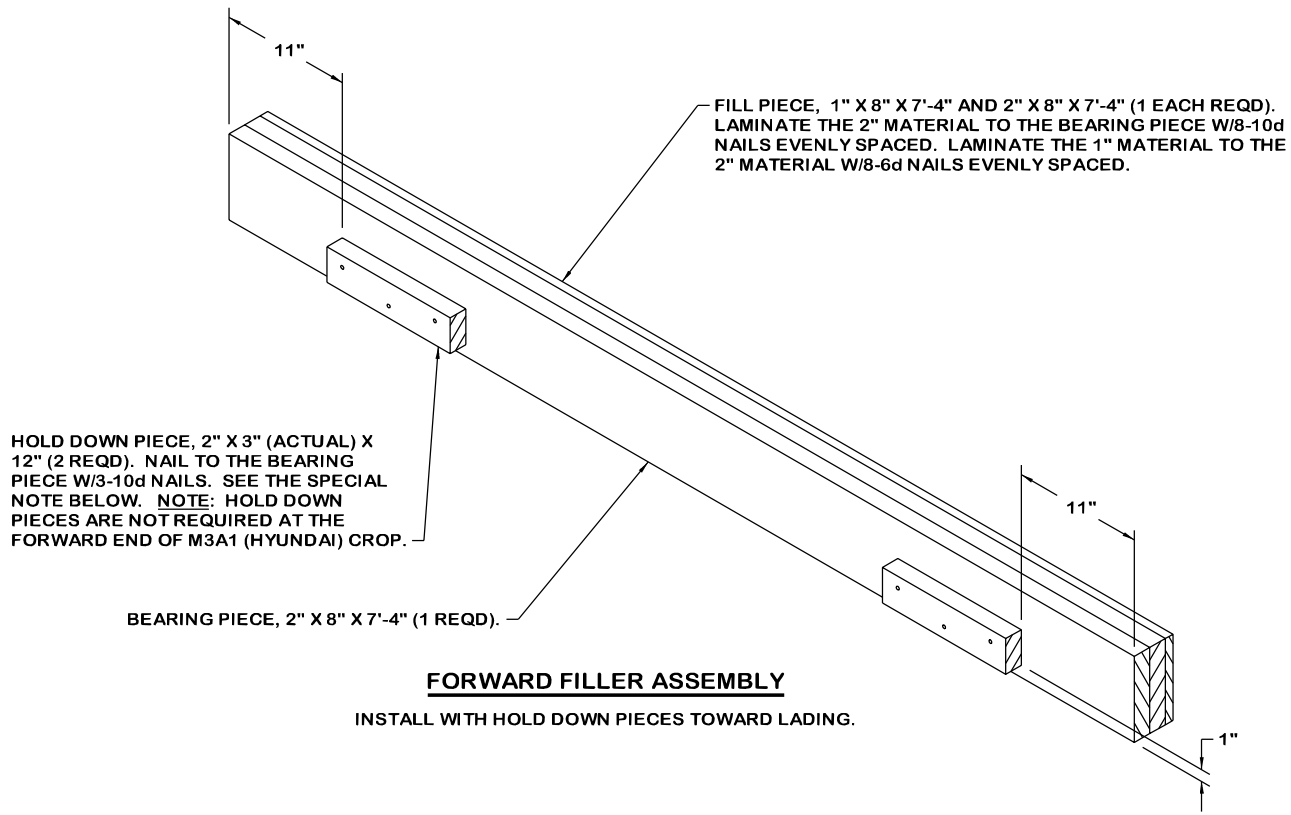

**FORWARD FILLER ASSEMBLY**

INSTALL WITH HOLD DOWN PIECES TOWARD LADING.

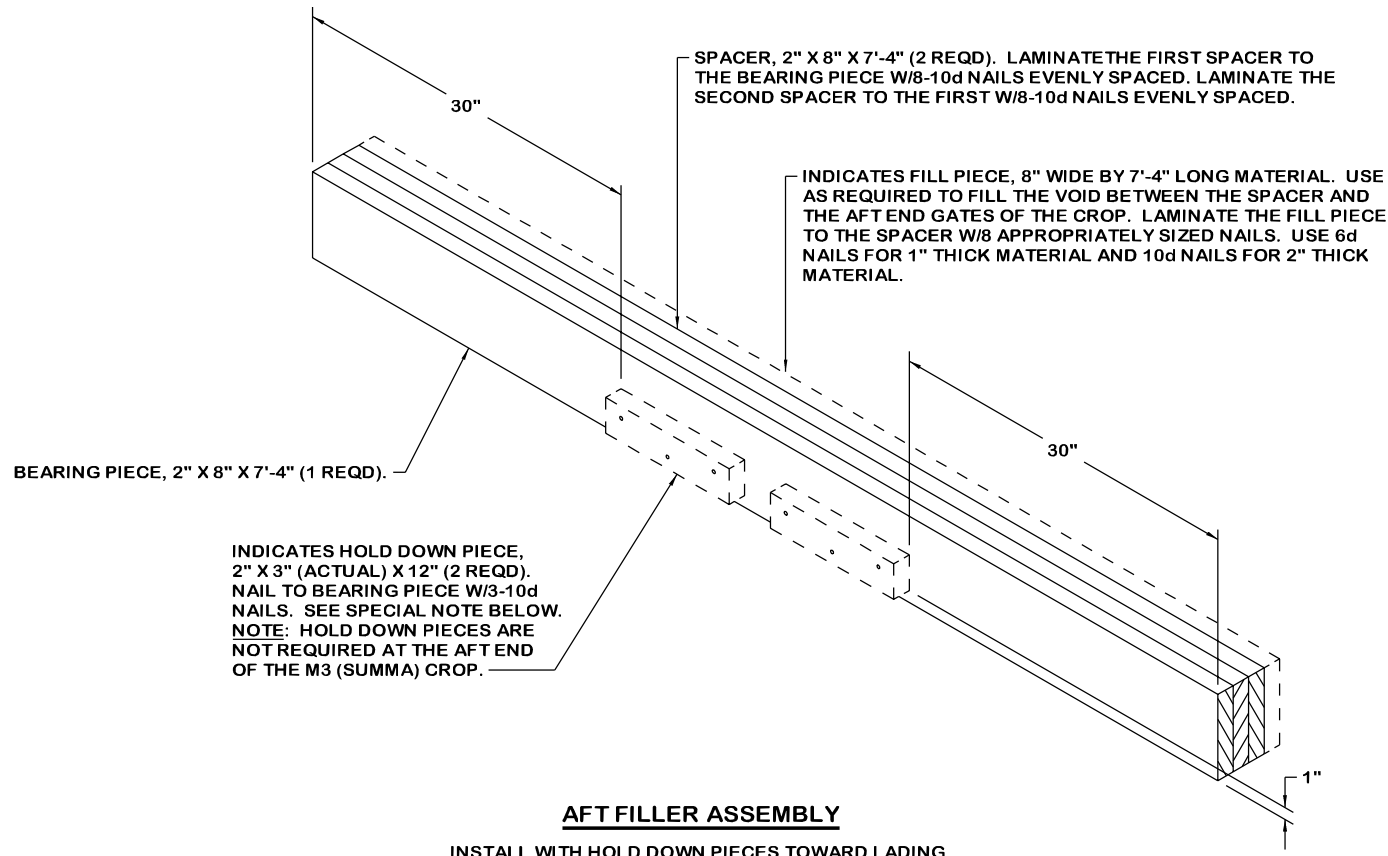

**AFT FILLER ASSEMBLY**

INSTALL WITH HOLD DOWN PIECES TOWARD LADING.

**SPECIAL NOTE:** HOLD DOWN PIECES (IF REQD) MUST BE RECESSED UNDERNEATH THE PALLET UNITS AND FIT BETWEEN THE PALLET SKIDS. FIELD CHECK DIMENSIONS BEFORE ASSEMBLY TO ENSURE A PROPER FIT. SEE GENERAL NOTES "B" AND "E" ON PAGE 3.

