

Om De

DATE 5/22/05

APPENDIX 44A

LOADING AND BRACING PROCEDURES FOR STRATEGIC CONFIGURED LOAD (SCL) ON CONTAINER ROLL IN/OUT PLATFORM (CROP)

SCL #44A - 105MM SMOKE WP M60A2



INDEX

<u>ITEM</u>	<u>PAGE(S)</u>
TYPICAL LOADING PROCEDURES - - - - -	2
GENERAL NOTES AND SEQUENTIAL LOADING PROCEDURES - - - - -	3
PALLET UNIT DETAIL - - - - -	4
DETAILS - - - - -	5

NOTICE: THIS APPENDIX CANNOT STAND ALONE BUT MUST BE USED IN CONJUNCTION WITH THE BASIC CROP OUTLOADING PROCEDURES DRAWING 19-48-4905-CA17Q6.

- LOADING AND BRACING SPECIFICATIONS SET FORTH WITHIN THIS DRAWING ARE APPLICABLE TO LOADS THAT ARE TO BE SHIPPED BY TRAILER/CONTAINER-ON-FLATCAR (T/COFC) RAIL CARRIER SERVICE. THESE SPECIFICATIONS MAY ALSO BE USED FOR LOADS THAT ARE TO BE MOVED BY MOTOR OR WATER CARRIERS.

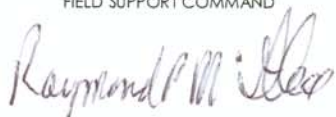
U.S. ARMY MATERIEL COMMAND DRAWING

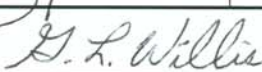
APPROVED, U.S. ARMY FIELD SUPPORT COMMAND 	CAUTION: VERIFY PRIOR TO USE AT WWW.DAC.ARMY.MIL THAT THIS IS THE MOST CURRENT VERSION OF THIS DOCUMENT. THIS IS PAGE 1 OF 6.				
APPROVED BY ORDER OF COMMANDING GENERAL, U.S. ARMY MATERIEL COMMAND  U.S. ARMY DEFENSE AMMUNITION CENTER	DO NOT SCALE	APRIL 2005			
	ENGINEER OR TECHNICIAN	BASIC REV.	RICHARD GARSIDE		
	TRANSPORTATION ENGINEERING DIVISION				
VALIDATION ENGINEERING DIVISION	TESTED	CLASS	DIVISION	DRAWING	
ENGINEERING DIRECTORATE		19	48	4905/ 44A	CA17Q6

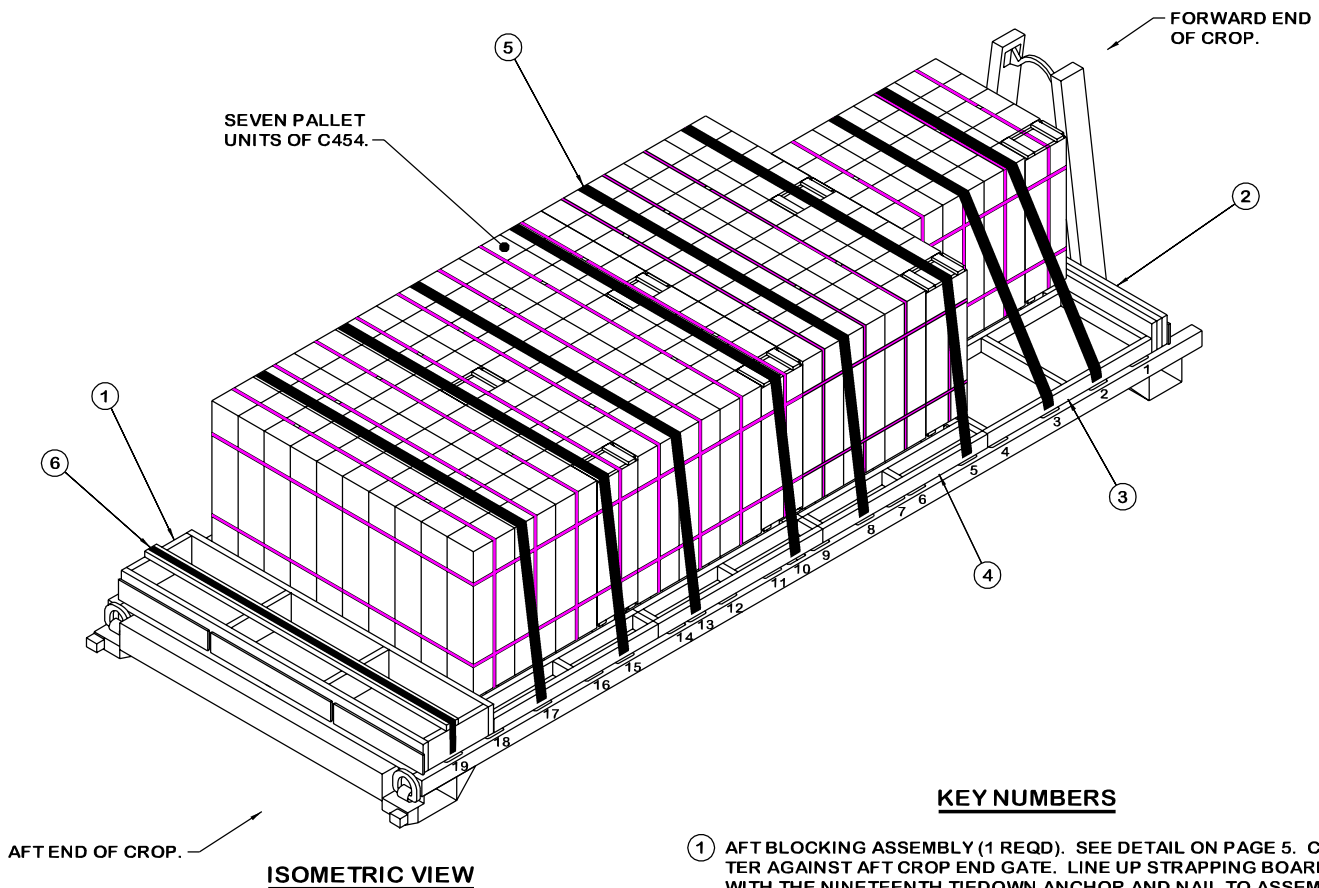

KEY NUMBERS

- ① AFT BLOCKING ASSEMBLY (1 REQD). SEE DETAIL ON PAGE 5. CENTER AGAINST AFT CROP END GATE. LINE UP STRAPPING BOARD WITH THE NINETEENTH TIEDOWN ANCHOR AND NAIL TO ASSEMBLY. NAIL W/2-12d NAILS THROUGH THE HOLES IN THE AFT CROP END GATE INTO THE AFT BLOCKING ASSEMBLY, LEAVING THE NAIL HEADS PROTRUDING THROUGH THE HOLES TO PROVIDE LATERAL RESTRAINT.
- ② FORWARD FILLER ASSEMBLY (1 REQD). SEE DETAIL ON PAGE 5. CENTER AGAINST FORWARD CROP END GATE AND, AFTER THE PALLET UNITS ARE LOADED, NAIL W/2-12d NAILS THROUGH THE HOLES IN THE FORWARD CROP END GATE INTO THE FORWARD FILLER PIECES, LEAVING THE NAIL HEADS PROTRUDING THROUGH THE HOLES TO PROVIDE LATERAL AND VERTICAL RESTRAINT.
- ③ SPACER ASSEMBLY (2 REQD). SEE DETAIL ON PAGE 5. POSITION A SPACER ASSEMBLY ON EACH SIDE OF THE FORWARD PALLET UNIT.
- ④ SIDE BLOCKING ASSEMBLY (6 REQD). SEE DETAIL ON PAGE 5. POSITION AGAINST THE PALLETS OF THE PALLET UNITS ON BOTH SIDES OF THE CROP AS SHOWN.
- ⑤ HOLD-DOWN STRAP, 3-INCH WIDE WEB STRAP TIEDOWN ASSEMBLY FOR CROP (8 REQD). INSTALL EACH HOLD-DOWN STRAP TO EXTEND FROM THE DESIGNATED TIEDOWN ANCHOR ON ONE SIDE OF CROP, OVER THE TOP OF THE C454 PALLET UNIT(S), AND DOWN TO THE CORRESPONDING TIEDOWN ANCHOR ON THE OPPOSITE SIDE OF THE CROP. ALIGN SCUFF SLEEVES OVER ALL SHARP EDGES AND FIRMLY TENSION STRAP. SEE GENERAL NOTE "F" ON PAGE 3.
- ⑥ RETAINER STRAP, 2-INCH WIDE WEB STRAP ASSEMBLY (1 REQD). INSTALL TO EXTEND FROM THE NINETEENTH TIEDOWN ANCHOR ON ONE SIDE OF CROP, OVER TOP OF THE AFT BLOCKING ASSEMBLY STRAPPING BOARD, TO THE NINETEENTH TIEDOWN ANCHOR ON OPPOSITE SIDE OF CROP. ALIGN SCUFF SLEEVES OVER ALL SHARP EDGES AND FIRMLY TENSION STRAP. SEE GENERAL NOTE "F" ON PAGE 3.

RECOMMENDED SEQUENTIAL PROCEDURES

1. PREFABRICATE THE FORWARD AND AFT BLOCKING ASSEMBLIES, TWO SPACER ASSEMBLIES, AND SIX SIDE BLOCKING ASSEMBLIES.
2. INSTALL THE AFT BLOCKING ASSEMBLY AGAINST THE AFT CROP END GATE, AS INSTRUCTED IN KEY NUMBER ①. SEE THE AFT BLOCKING ASSEMBLY DETAIL ON PAGE 5. NAIL TWO 12d RETAINER NAILS INTO THE AFT BLOCKING ASSEMBLY, AS INSTRUCTED IN KEY NUMBER ①.
3. LOAD SIX C454 PALLET UNITS ON THE CROP, IN THREE ROWS OF TWO. CENTER THE FIRST ROW OF PALLET UNITS AGAINST THE AFT BLOCKING ASSEMBLY AND PLACE EACH REMAINING ROW OF PALLET UNITS TIGHT AGAINST THE PREVIOUS ROW OF PALLET UNITS.
4. LOAD ONE C454 PALLET UNIT ON THE CROP, CENTERED AGAINST THE PREVIOUS ROW OF PALLET UNITS, ORIENTED LIKE THE PREVIOUS PALLET UNITS.
5. INSTALL THE FORWARD FILLER ASSEMBLY BETWEEN THE FORWARD PALLET UNIT AND THE FORWARD CROP END GATE AND CENTERED ON THE GATE, AS NOTED IN KEY NUMBER ②. THE CLEATS OF THE ASSEMBLY SHOULD PROTRUDE UNDER THE FORWARD PALLET UNIT. NAIL TWO 12d RETAINER NAILS INTO THE FORWARD FILLER ASSEMBLY, AS INSTRUCTED IN KEY NUMBER ②.
6. INSTALL TWO SPACER ASSEMBLIES, AS NOTED IN KEY NUMBER ③.
7. INSTALL SIX SIDE BLOCKING ASSEMBLIES, AS NOTED IN KEY NUMBER ④.
8. INSTALL EIGHT HOLD-DOWN STRAPS, AS NOTED IN KEY NUMBER ⑤.
9. INSTALL AFT BLOCKING ASSEMBLY RESTRAINT STRAP, AS NOTED IN KEY NUMBER ⑥.
10. NAIL THROUGH THE HOOK ATTACHMENT SLOT OF EACH HOLD-DOWN AND RESTRAINT STRAP INTO THE BLOCKING ASSEMBLIES W/1-10d PARTIALLY DRIVEN NAIL AND BEND OVER SIDE OF HOOK.

GENERAL NOTES

- A. THIS APPENDIX CANNOT STAND ALONE BUT MUST BE USED IN CONJUNCTION WITH THE BASIC LOADING PROCEDURES DRAWING 19-48-4905-CA17Q6. TO PRODUCE AN APPROVED LOAD, ALL PERTINENT PROCEDURES, SPECIFICATIONS AND CRITERIA SET FORTH WITHIN THE BASIC DRAWING WILL APPLY TO THE PROCEDURES DELINEATED IN THIS APPENDIX. ANY EXCEPTIONS TO THE BASIC PROCEDURES ARE SPECIFIED IN THIS APPENDIX.
- B. THE OUTLOADING PROCEDURES DEPICTED IN THIS DRAWING ARE APPLICABLE TO LOADS OF SCL #44A. SEE PAGE 4 FOR THE DETAIL OF THE PALLET UNIT. AN M3A1 (HYUNDAI) CROP IS SHOWN AS TYPICAL. OTHER MANUFACTURER'S CROPS CAN BE USED FOR THE LOAD SHOWN ON PAGE 2. THE SEQUENTIAL LOADING PROCEDURES DEPICTED AT LEFT DESCRIBE THE SEQUENCE USED TO LOAD AN M3A1 CROP. FOR AN M3 (SUMMA) CROP, SEQUENTIAL LOADING PROCEDURES 2 THROUGH 5 MUST BE REVERSED. ACTUAL CROP CONFIGURATION WILL DETERMINE WHETHER THE SEQUENTIAL LOADING STARTS AT THE AFT OR THE FORWARD END OF THE CROP.
- C. THE LOADING PROCEDURES DEPICTED HEREIN MAY ALSO BE USED FOR OUTLOADING SIMILAR SCL LOADS WHEN IDENTIFIED BY DIFFERENT NATIONAL STOCK NUMBERS (NSN) THAN WHAT IS SHOWN ON PAGE 4, PROVIDED THE OVERALL PALLET UNIT DIMENSIONS DO NOT VARY FROM WHAT IS DELINEATED HEREIN.
- D. DIMENSIONS, CUBE AND WEIGHT OF THE PALLET UNITS WILL VARY SLIGHTLY DEPENDING UPON THE ACTUAL DIMENSIONS OF THE BOXES AND THE WEIGHT OF THE SPECIFIC ITEM BEING UNITIZED.
- E. DIMENSIONS GIVEN FOR DUNNAGE ASSEMBLIES WILL BE FIELD CHECKED PRIOR TO THEIR ASSEMBLY. PALLET UNITS MUST FIT SNUGLY AGAINST THE DUNNAGE ASSEMBLIES. THIS GUIDANCE MUST BE APPLIED PRIOR TO BEGINNING AN OUTLOADING OPERATION. ALSO, DUE TO VARIATION OF PALLET UNIT DIMENSIONS, ADJUSTMENTS MAY BE REQUIRED AS TO THE LOCATION OF CERTAIN PIECES ON DUNNAGE ASSEMBLIES.
- F. ALL WEB STRAP TIEDOWN ASSEMBLIES MUST HAVE THE EXCESS LENGTH OF THE STRAP SECURED. ROLL UP AND BUNDLE THE EXCESS LENGTH OF WEB STRAP, SECURING WITH CABLE TIES. SEE THE "STRAP END SECUREMENT" DETAIL AND GENERAL NOTE "K.12" IN THE BASIC PROCEDURE DRAWING 19-48-4905-CA17Q6.
- G. UNUSED WEB STRAP TIEDOWN ASSEMBLIES MUST BE SECURED AS DELINEATED IN GENERAL NOTE "K.13" IN THE BASIC PROCEDURE DRAWING 19-48-4905-CA17Q6.
- H. CONVERSION TO METRIC EQUIVALENTS: DIMENSIONS WITHIN THIS DOCUMENT ARE EXPRESSED IN INCHES, AND WEIGHTS ARE EXPRESSED IN POUNDS. WHEN NECESSARY, THE METRIC EQUIVALENTS MAY BE COMPUTED ON THE BASIS OF ONE INCH EQUALS 25.4MM AND ONE POUND EQUALS 0.454 KG.

BILL OF MATERIAL		
LUMBER	LINEAR FEET	BOARD FEET
1" X 8"	8	5
2" X 3"	2	2
2" X 4"	91	61
2" X 8"	43	58
NAILS	NO. REQD	POUNDS
6d (2")	8	NIL
10d (3")	156	2-1/2
12d (3-1/4")	4	NIL
2" WEB STRAP TIEDOWN ASSY - - - 1 REQD - - - 6 LBS		

LOAD AS SHOWN

ITEM	QUANTITY	WEIGHT (APPROX)
C454 PALLET UNIT	7	17,304 LBS
DUNNAGE		251 LBS
CROP		3,800 LBS
TOTAL WEIGHT		21,355 LBS (APPROX)

SCL #44A COMPOSITION CHART

DODIC	NSN	NOMENCLATURE	UNIT DWG	REQD	UNITS REQD	HC
C454	1315-00-113-5741	CARTRIDGE, 105MM SMOKE WP M60A2 W/FUZE	4015/7	280	7 PALLETS	1.2H

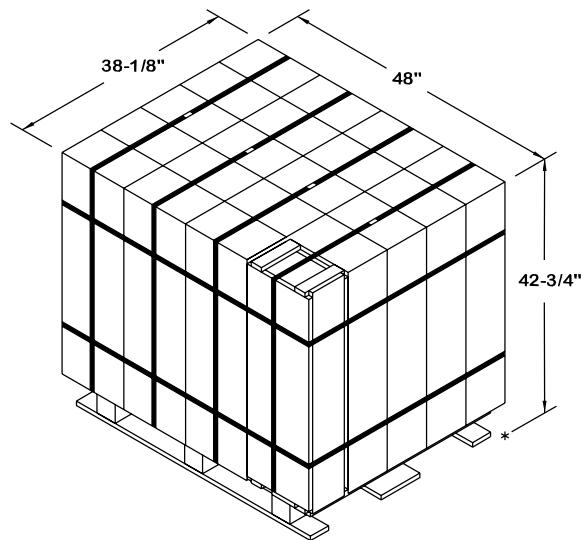

C454 PALLET UNIT DETAIL

20 BOXES OF 105MM CARTRIDGES	
(2 PER BOX) AT 120 LBS - - - - -	2,400 LBS (APPROX)
DUNNAGE - - - - -	7 LBS
PALLET - - - - -	65 LBS

TOTAL WEIGHT - - - - -	2,472 LBS (APPROX)
CUBE - - - - -	45.3 CU FT (APPROX)

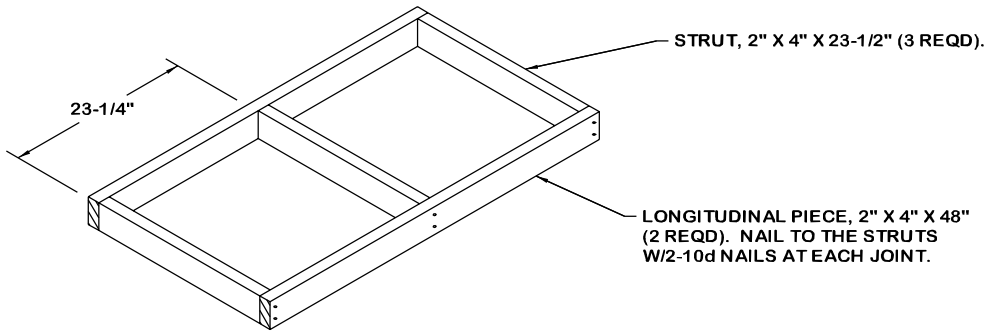

SPACER ASSEMBLY

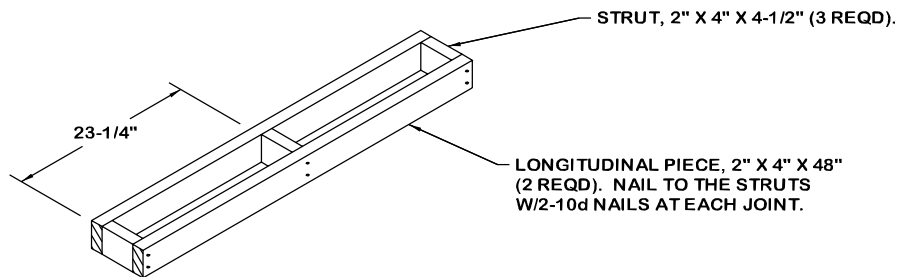

SIDE BLOCKING ASSEMBLY

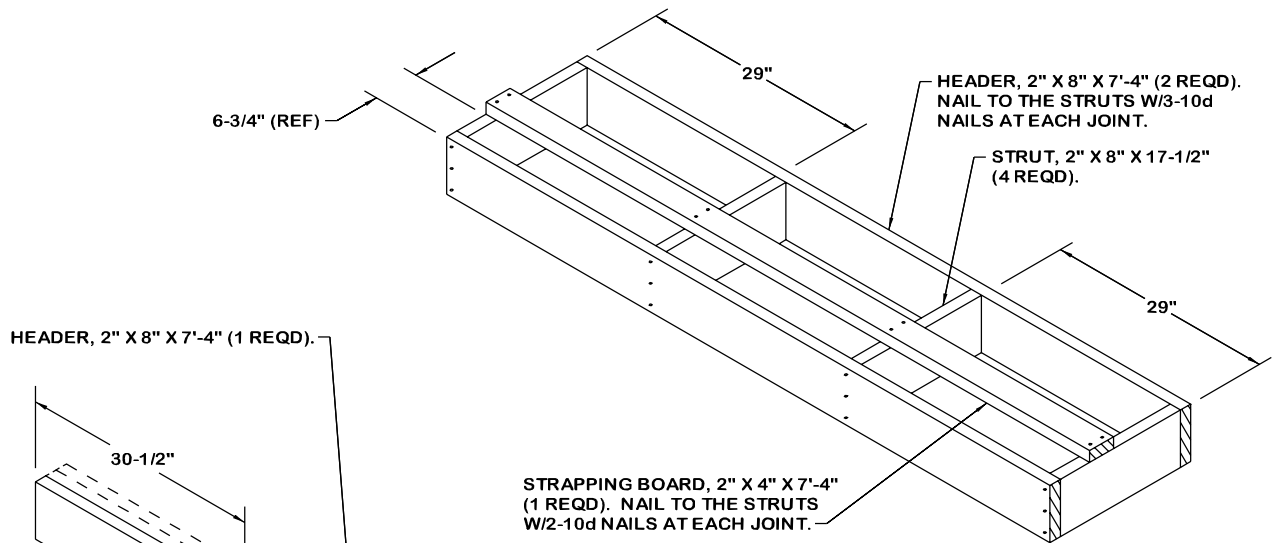

AFT BLOCKING ASSEMBLY

CLEAT, 2" X 3" X 10" (2 REQD). NAIL TO THE HEADER W/2-10d NAILS.

FORWARD FILLER ASSEMBLY

THIS FORWARD FILLER ASSEMBLY WILL BE PLACED AT THE FRONT OF THE LOAD WITH THE CLEATS RECESSED UNDER THE FRONT PALLET UNIT. FIELD CHECK PALLET UNIT TO VERIFY PROPER CLEAT LOCATIONS.

FILL PIECE, 1" OR 2" X 8" X 7'-4" (AS REQD, TWO SHOWN). LAMINATE EACH PIECE TO THE PREVIOUS PIECE W/8 NAILS OF A SUITABLE SIZE (6d NAILS FOR 1" THICK MATERIAL OR 10d NAILS FOR 2" THICK MATERIAL).

1"

