

J. L.

DATE 5/22/05

APPENDIX 36B

LOADING AND BRACING PROCEDURES FOR STRATEGIC CONFIGURED LOAD (SCL) ON CONTAINER ROLL IN/OUT PLATFORM (CROP)

SCL #36B - 155MM HERA M549A1 W/O FUZES

INDEX

<u>ITEM</u>	<u>PAGE(S)</u>
TYPICAL LOADING PROCEDURES - - - - -	2
GENERAL NOTES AND SEQUENTIAL LOADING PROCEDURES - - - - -	3
BOX AND PALLET UNIT DETAILS - - - - -	4
DETAILS - - - - -	5-6

NOTICE: THIS APPENDIX CANNOT STAND ALONE BUT MUST BE USED IN CONJUNCTION WITH THE BASIC CROP OUTLOADING PROCEDURES DRAWING 19-48-4905-CA17Q6.

- LOADING AND BRACING SPECIFICATIONS SET FORTH WITHIN THIS DRAWING ARE APPLICABLE TO LOADS THAT ARE TO BE SHIPPED BY TRAILER/CONTAINER-ON-FLATCAR (T/COFC) RAIL CARRIER SERVICE. THESE SPECIFICATIONS MAY ALSO BE USED FOR LOADS THAT ARE TO BE MOVED BY MOTOR OR WATER CARRIERS.

U.S. ARMY MATERIEL COMMAND DRAWING

APPROVED, U.S. ARMY FIELD SUPPORT COMMAND <i>Raymond P. McShane</i>	CAUTION: VERIFY PRIOR TO USE AT WWW.DAC.ARMY.MIL THAT THIS IS THE MOST CURRENT VERSION OF THIS DOCUMENT. THIS IS PAGE 1 OF 6.					
	DO NOT SCALE		JUNE 2005			
APPROVED BY ORDER OF COMMANDING GENERAL, U.S. ARMY MATERIEL COMMAND <i>Charles P. Stoo</i> U.S. ARMY DEFENSE AMMUNITION CENTER	ENGINEER OR TECHNICIAN	BASIC REV.	LAURA A. FIEFFER			
	TRANSPORTATION ENGINEERING DIVISION	<i>G. L. Willis</i>				
	VALIDATION ENGINEERING DIVISION	TESTED	CLASS	DIVISION	DRAWING	
ENGINEERING DIRECTORATE	<i>G. L. Willis</i>		19	48	4905/ 36B	CA17Q6

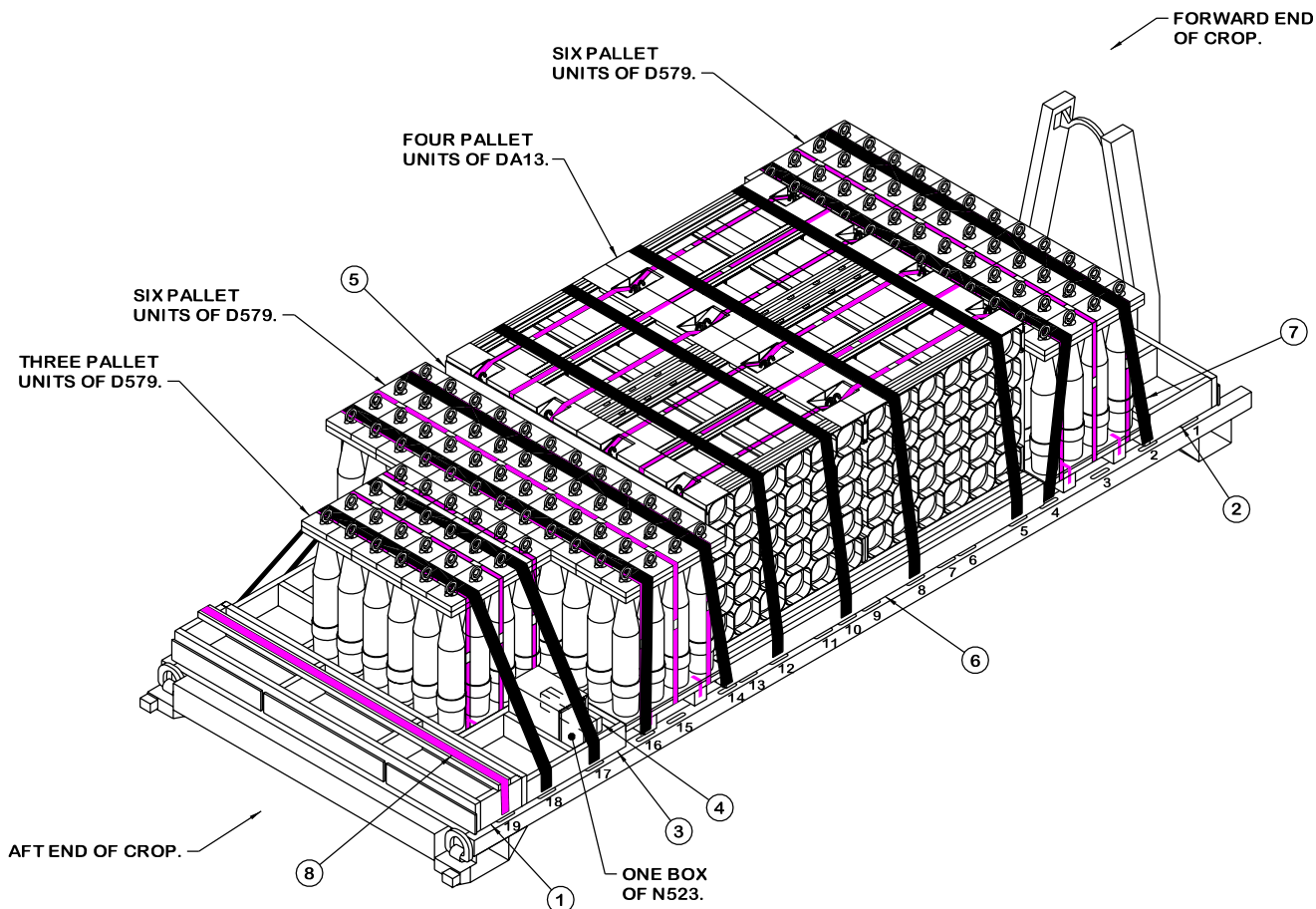

ISOMETRIC VIEW

(KEY NUMBERS CONTINUED)

- ⑦ HOLD-DOWN STRAP, 3-INCH WIDE WEB STRAP TIEDOWN ASSEMBLY FOR CROP (10 REQD). INSTALL EACH HOLD-DOWN STRAP TO EXTEND FROM THE DESIGNATED TIEDOWN ANCHOR ON ONE SIDE OF CROP, OVER THE TOP OF THE PALLET UNITS, TO THE CORRESPONDING TIEDOWN ANCHOR ON THE OPPOSITE SIDE OF THE CROP. ALIGN SCUFF SLEEVES OVER ALL SHARP EDGES AND FIRMLY TENSION STRAP. SEE GENERAL NOTE "F" ON PAGE 3.
- ⑧ RETAINER STRAP, 2" WIDE WEB STRAP TIEDOWN ASSEMBLY (1 REQD). INSTALL TO EXTEND FROM THE NINETEENTH TIEDOWN RING ON ONE SIDE OF THE CROP, OVER THE TOP OF THE STRAPPING BOARD OF THE AFT FILLER ASSEMBLY, TO THE NINETEENTH TIEDOWN RING ON THE OPPOSITE SIDE OF THE CROP. POSITION SCUFF SLEEVES OVER ALL SHARP EDGES AND FIRMLY TENSION STRAP. SEE GENERAL NOTE "F" ON PAGE 3.

KEY NUMBERS

- ① AFT FILLER ASSEMBLY (1 REQD). SEE DETAIL ON PAGE 5. CENTER AGAINST AFT CROP END GATE AND, AFTER THE PALLET UNITS ARE LOADED, NAIL W/2-12d NAILS THRU THE SLOTS IN THE AFT CROP END GATE INTO THE AFT FILLER ASSEMBLY, LEAVING THE NAIL HEADS PROTRUDING THRU THE SLOTS TO PROVIDE LATERAL RESTRAINT.
- ② FORWARD FILLER ASSEMBLY (1 REQD). SEE DETAIL ON PAGE 5. CENTER AGAINST FORWARD CROP END GATE AND, AFTER THE PALLET UNITS ARE LOADED, NAIL W/2-12d NAILS THRU THE HOLES IN THE FORWARD CROP END GATE INTO THE FORWARD FILLER ASSEMBLY, LEAVING THE NAIL HEADS PROTRUDING THRU THE HOLES TO PROVIDE LATERAL AND VERTICAL RESTRAINT.
- ③ SIDE BLOCKING ASSEMBLY A (2 REQD). SEE THE DETAIL ON PAGE 6. INSTALL ONE ON EACH SIDE OF THE CROP ADJACENT TO THE ROW OF THREE D579 PALLET UNITS. AFTER THE HOLD-DOWN STRAPS ARE INSTALLED, NAIL THROUGH THE STRAP ATTACHMENT SLOTS OF TWO HOLD-DOWN STRAPS INTO SIDE BLOCKING W/1-10d PARTIALLY DRIVEN NAIL AND BEND OVER SIDE OF HOOK.
- ④ N523 RETAINER PIECE, 2" X 4" X 15" (DOUBLED) (1 REQD). SEE THE "SECTION VIEW A-A" DETAIL ON PAGE 6. INSTALL TO RETAIN THE N523 BOX WITHIN ONE SIDE BLOCKING ASSEMBLY "A", ON THE END ADJACENT TO THE SIX PALLET UNIT ROW OF D579. NAIL THE FIRST PIECE TO THE LATERAL PIECE OF THE SIDE BLOCKING ASSEMBLY "A" W/3-10d NAILS. LAMINATE THE SECOND PIECE TO THE FIRST IN A LIKE MANNER.
- ⑤ SEPARATOR GATE (2 REQD). SEE THE DETAIL ON PAGE 6.
- ⑥ SIDE BLOCKING ASSEMBLY B (2 REQD). SEE THE DETAIL ON PAGE 6. INSTALL ONE ON EACH SIDE OF THE CROP ADJACENT TO THE DA13 PALLET UNITS. AFTER THE HOLD-DOWN STRAPS ARE INSTALLED, NAIL THROUGH THE STRAP ATTACHMENT SLOTS OF TWO HOLD-DOWN STRAPS (ONE AT EACH END OF THE ASSEMBLY) INTO SIDE BLOCKING W/1-10d PARTIALLY DRIVEN NAIL AND BEND OVER SIDE OF HOOK.

(CONTINUED AT LEFT)

RECOMMENDED SEQUENTIAL PROCEDURES

1. PREFABRICATE THE AFT FILLER ASSEMBLY, THE FORWARD FILLER ASSEMBLY, TWO SIDE BLOCKING ASSEMBLIES "A", TWO SIDE BLOCKING ASSEMBLIES "B", AND TWO SEPARATOR GATES.
2. INSTALL THE AFT FILLER ASSEMBLY.
3. LOAD ONE ROW OF THREE PALLET UNITS OF D579 AGAINST THE AFT END FILLER ASSEMBLY, CENTERING THE ROW LATERALLY ON THE CROP.
4. LOAD ONE ROW OF SIX PALLET UNITS OF D579 AGAINST THE FIRST D579 PALLET UNITS, CENTERING THE ROW LATERALLY ON THE CROP.
5. INSTALL ONE SEPARATOR GATE, WITH THE HOLD-DOWN PIECES AWAY FROM THE D579 PALLET UNITS.
6. LOAD TWO ROWS OF TWO PALLET UNITS OF DA13 AGAINST THE D579 PALLET UNITS, CENTERING THE ROWS LATERALLY ON THE CROP.
7. INSTALL ONE SEPARATOR GATE, WITH THE HOLD-DOWN PIECES UNDER THE DA13 PALLET UNITS.
8. LOAD ONE ROW OF SIX PALLET UNITS OF D579 AGAINST THE DA13 PALLET UNITS, CENTERING THE ROW LATERALLY ON THE CROP.
9. INSTALL THE FORWARD FILLER ASSEMBLY.
10. INSTALL THE TWO SIDE BLOCKING ASSEMBLIES "A", ONE ON EITHER SIDE OF THE THREE D579 PALLET UNITS.
11. INSTALL THE TWO SIDE BLOCKING ASSEMBLIES "B", ONE ON EITHER SIDE OF THE DA13 PALLET UNITS.
12. INSTALL THE N523 RETAINER PIECE, AS DELINEATED IN KEY NUMBER ④, AND LOAD ONE BOX OF N523 INTO THE SIDE BLOCKING ASSEMBLY "A".
13. INSTALL 10 WEB STRAP TIEDOWN ASSEMBLIES AS DELINEATED IN KEY NUMBER ⑦.
14. NAIL THROUGH THE STRAP ATTACHMENT SLOT OF A HOLD-DOWN STRAP INTO EACH END OF THE SIDE BLOCKING ASSEMBLIES W/1-10d PARTIALLY DRIVEN NAIL AND BEND OVER SIDE OF HOOK.
15. INSTALL RETAINER STRAP AS DELINEATED IN KEY NUMBER ⑥.
16. NAIL TWO 12d RETAINING NAILS THRU THE SLOTS IN THE AFT CROP END GATE AS DELINEATED IN KEY NUMBER ①.
17. NAIL THE TWO REMAINING 12d RETAINING NAILS THRU THE HOLES IN THE FORWARD CROP END GATE AS DELINEATED IN KEY NUMBER ②.

GENERAL NOTES

- A. THIS APPENDIX CANNOT STAND ALONE BUT MUST BE USED IN CONJUNCTION WITH THE BASIC LOADING PROCEDURES DRAWING 19-48-4905-CA17Q6. TO PRODUCE AN APPROVED LOAD, ALL PERTINENT PROCEDURES, SPECIFICATIONS AND CRITERIA SET FORTH WITHIN THE BASIC DRAWING WILL APPLY TO THE PROCEDURES DELINEATED IN THIS APPENDIX. ANY EXCEPTIONS TO THE BASIC PROCEDURES ARE SPECIFIED IN THIS APPENDIX.
- B. THE OUTLOADING PROCEDURES DEPICTED IN THIS DRAWING ARE APPLICABLE TO LOADS OF SCL #36B. SEE PAGE 4 FOR DETAILS OF THE PALLET UNITS. AN M3A1 (HYUNDAI) CROP IS SHOWN AS TYPICAL. OTHER MANUFACTURER'S CROPS CAN BE USED FOR THE LOAD SHOWN ON PAGE 2. THE SEQUENTIAL LOADING PROCEDURES DEPICTED AT LEFT DESCRIBE THE SEQUENCE USED TO LOAD AN M3A1 CROP. FOR AN M3 (SUMMA) CROP, SEQUENTIAL LOADING PROCEDURES 2 THROUGH 9 MUST BE REVERSED. ACTUAL CROP CONFIGURATION WILL DETERMINE WHETHER THE SEQUENTIAL LOADING STARTS AT THE AFT OR THE FORWARD END OF THE CROP.
- C. THE LOADING PROCEDURES DEPICTED HEREIN MAY ALSO BE USED FOR OUTLOADING SIMILAR SCL LOADS WHEN IDENTIFIED BY DIFFERENT NATIONAL STOCK NUMBERS (NSN) THAN WHAT IS SHOWN ON PAGE 4, PROVIDED THE OVERALL PALLET UNIT DIMENSIONS DO NOT VARY FROM WHAT IS DELINEATED HEREIN.
- D. DIMENSIONS, CUBE AND WEIGHT OF THE PALLET UNITS WILL VARY SLIGHTLY DEPENDING UPON THE ACTUAL DIMENSIONS OF THE BOXES AND THE WEIGHT OF THE SPECIFIC ITEM BEING UNITIZED.
- E. DIMENSIONS GIVEN FOR DUNNAGE ASSEMBLIES WILL BE FIELD CHECKED PRIOR TO THEIR ASSEMBLY. PALLET UNITS MUST FIT SNUGLY AGAINST THE DUNNAGE ASSEMBLIES. THIS GUIDANCE MUST BE APPLIED PRIOR TO BEGINNING AN OUTLOADING OPERATION. ALSO, DUE TO VARIATION OF PALLET UNIT DIMENSIONS, ADJUSTMENTS MAY BE REQUIRED AS TO THE LOCATION OF CERTAIN PIECES ON DUNNAGE ASSEMBLIES.
- F. ALL WEB STRAP TIEDOWN ASSEMBLIES MUST HAVE THE EXCESS LENGTH OF THE STRAP SECURED. ROLL UP AND BUNDLE THE EXCESS LENGTH OF WEB STRAP, SECURING WITH CABLE TIES. SEE THE "STRAP END SECUREMENT" DETAIL AND GENERAL NOTE "K.12" IN THE BASIC PROCEDURE DRAWING 19-48-4905-CA17Q6.
- G. UNUSED WEB STRAP TIEDOWN ASSEMBLIES MUST BE SECURED AS DELINEATED IN GENERAL NOTE "K.13" IN THE BASIC PROCEDURES DRAWING 19-48-4905-CA17Q6.
- H. CONVERSION TO METRIC EQUIVALENTS: DIMENSIONS WITHIN THIS DOCUMENT ARE EXPRESSED IN INCHES, AND WEIGHTS ARE EXPRESSED IN POUNDS. WHEN NECESSARY, THE METRIC EQUIVALENTS MAY BE COMPUTED ON THE BASIS OF ONE INCH EQUALS 25.4MM AND ONE POUND EQUALS 0.454 KG.

BILL OF MATERIAL

LUMBER	LINEAR FEET	BOARD FEET
2" X 3" (ACTUAL)	5	3
2" X 4"	17	11
2" X 6"	82	82
2" X 8"	41	55
NAILS	NO. REQD	POUNDS
6d (2")	12	1/4
10d (3")	178	2-3/4
12d (3-1/4")	4	1/4
PLYWOOD, 1/4" - - -	44.33 SQ FT REQD	- - 30-1/2 LBS
2" WEB STRAP TIEDOWN ASSY - - -	1 REQD	- - - 6 LBS

LOAD AS SHOWN

ITEM	QUANTITY	WEIGHT (APPROX)
D579 PALLET UNIT - - - -	15 - - - - -	12, 225 LBS
DA13 PALLET UNIT - - - -	4 - - - - -	7, 340 LBS
N523 BOX - - - - -	1 - - - - -	34 LBS
DUNNAGE - - - - -	- - - - -	338 LBS
CROP - - - - -	- - - - -	3, 800 LBS
TOTAL WEIGHT - - - - -		23, 737 LBS (APPROX)

SCL #36B COMPOSITION CHART

DODIC	NSN	NOMENCLATURE	UNIT DWG	REQD	UNITS REQD	HC
D579	1320-01-047-6009	PROJ, 155MM HERA M549A1	9327883	120	15 PALLETS	1. 1D
DA13	1320-01-457-4063	MODULAR ARTILLERY CHARGE SYSTEM (MACS), M232	4326/50A	600	4 PALLETS	1. 3C
N523	1390-01-481-2024	PRIMER, PERCUSSION M82	4116/158G	200	1 BOX	1. 4S

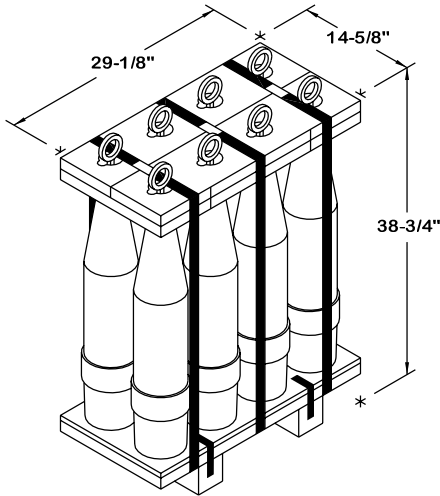

D579 PALLET UNIT DETAIL

8 155MM CTG @ 96-7/8 LBS - - - - - 775 LBS (APPROX)
 DUNNAGE AND PALLET - - - - - 40 LBS

TOTAL WEIGHT - - - - - 815 LBS (APPROX)
 CUBE - - - - - 9.6 CU FT (APPROX)

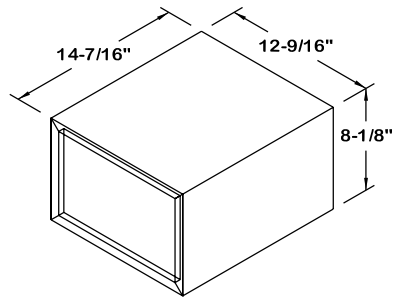

N523 BOX DETAIL

GROSS WEIGHT - - - - - 34 LBS (APPROX)
 CUBE - - - - - 0.9 CU FT (APPROX)

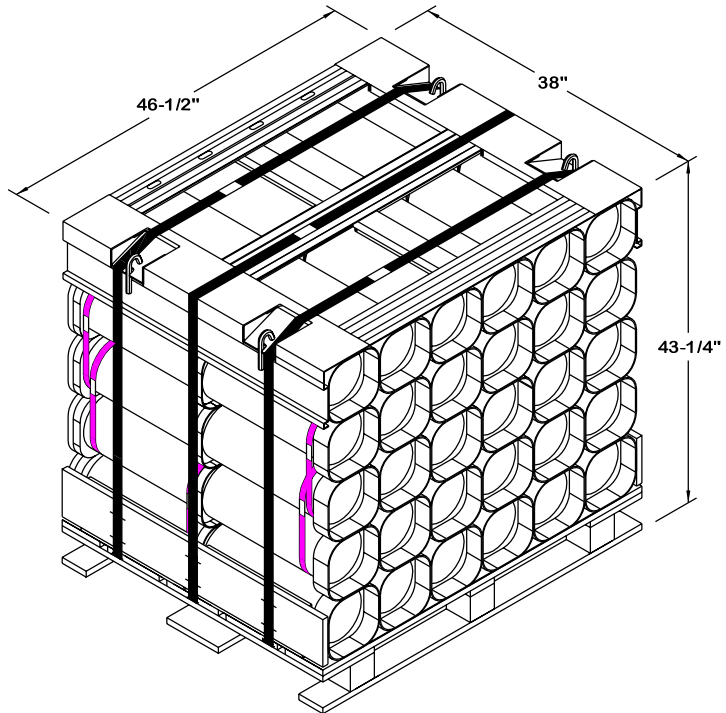

DA13 PALLET UNIT DETAIL

30 CONTAINERS OF MACS PROPELLING
 CHARGES (5 PER CONTAINER) @ 55 LBS - - - - - 1,650 LBS (APPROX)
 DUNNAGE - - - - - 110 LBS
 PALLET - - - - - 75 LBS

TOTAL WEIGHT - - - - - 1,835 LBS (APPROX)
 CUBE - - - - - 44.3 CU FT (APPROX)

STRAPPING BOARD, 2" X 4" X 7'-4"
(1 REQD). NAIL TO THE STRUTS
W/2-10d NAILS AT EACH JOINT.

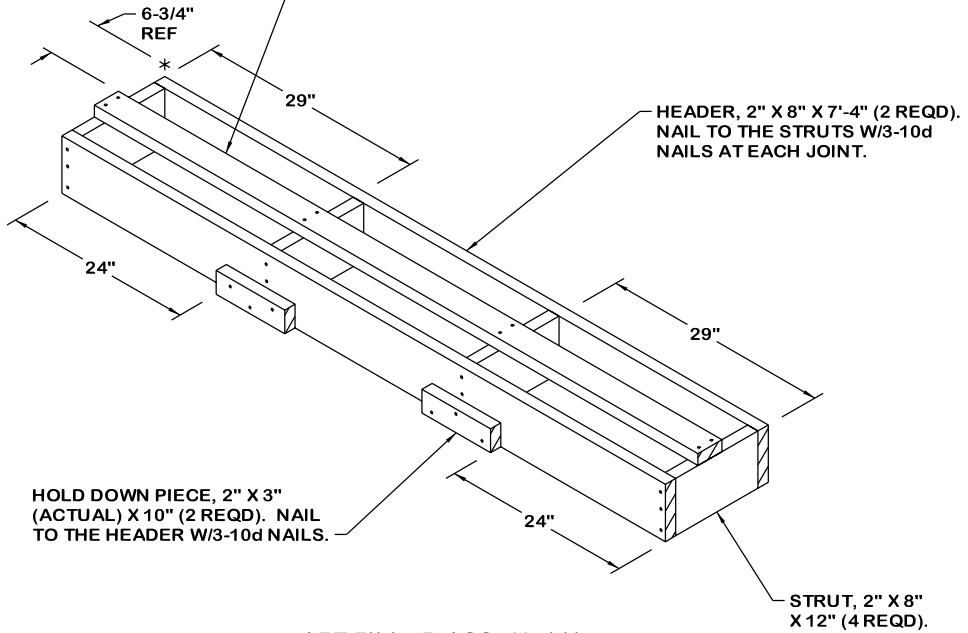

AFT FILLER ASSEMBLY

INSTALL WITH THE HOLD DOWN PIECES TOWARDS THE LADING. ENSURE THAT THE STRAPPING BOARD IS IN ALIGNMENT WITH THE NINETEENTH TIEDOWN ANCHOR.

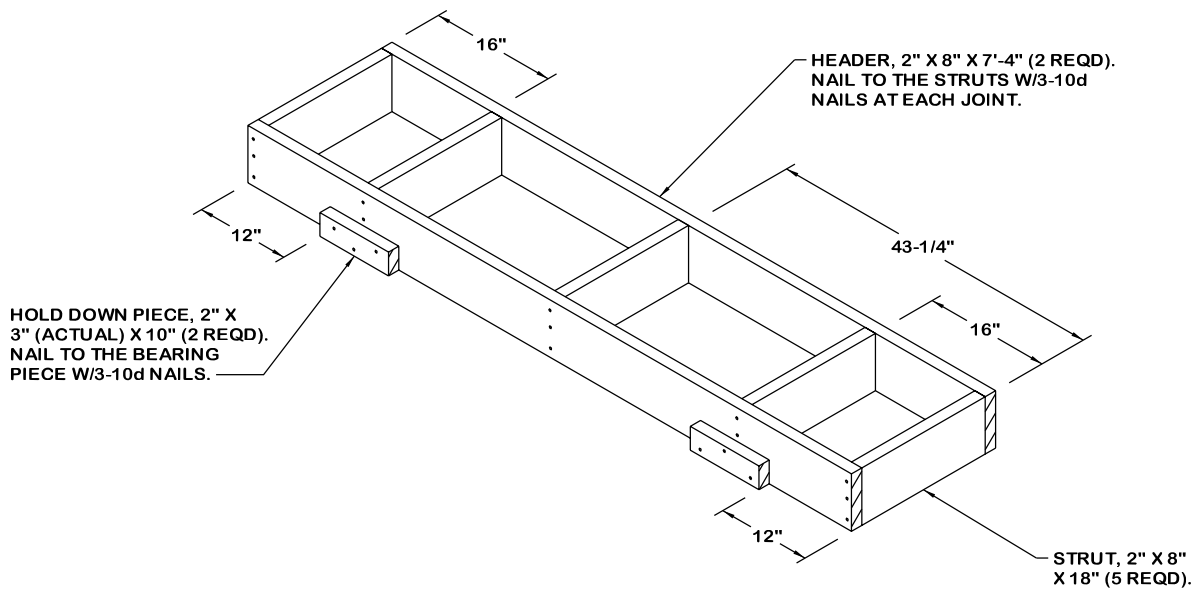

FORWARD FILLER ASSEMBLY

INSTALL WITH THE HOLD DOWN PIECES TOWARDS THE LADING.

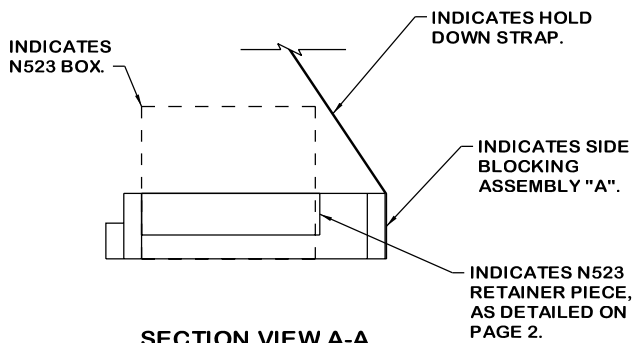

SECTION VIEW A-A

THIS SECTION VIEW PROVIDES DETAILS FOR THE INSTALLATION OF THE N523 RETAINER PIECE AND THE SECUREMENT OF THE N523 BOX.

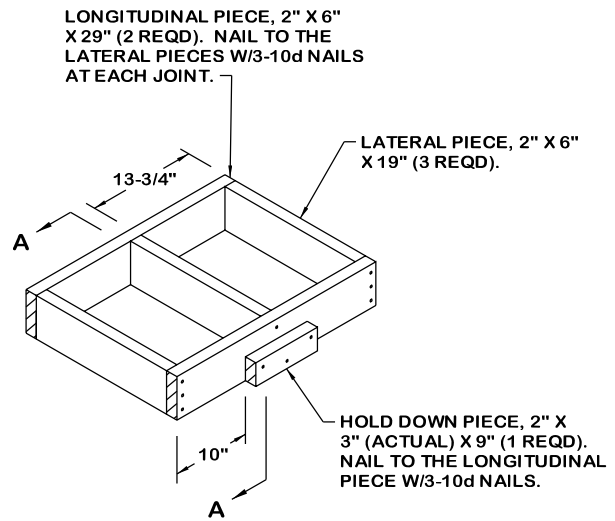

SIDE BLOCKING ASSEMBLY A

INSTALL WITH THE HOLD DOWN PIECE TOWARDS THE LADING.

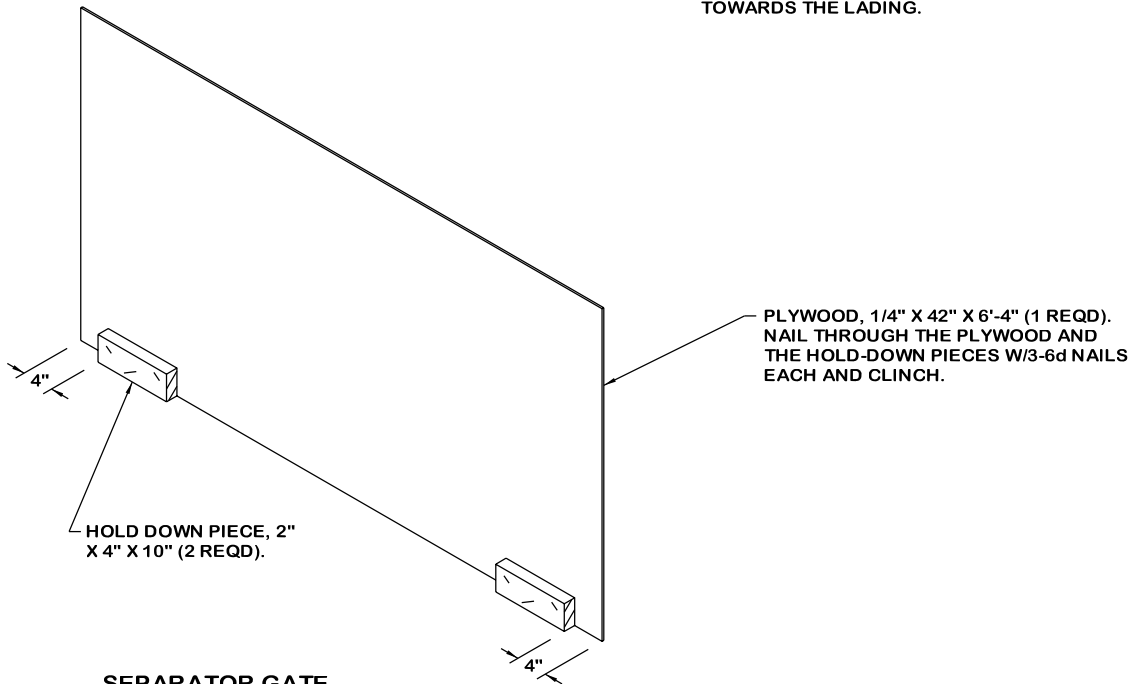

SEPARATOR GATE

INSTALL WITH THE HOLD DOWN PIECES TOWARDS THE DA13 PALLET UNITS.

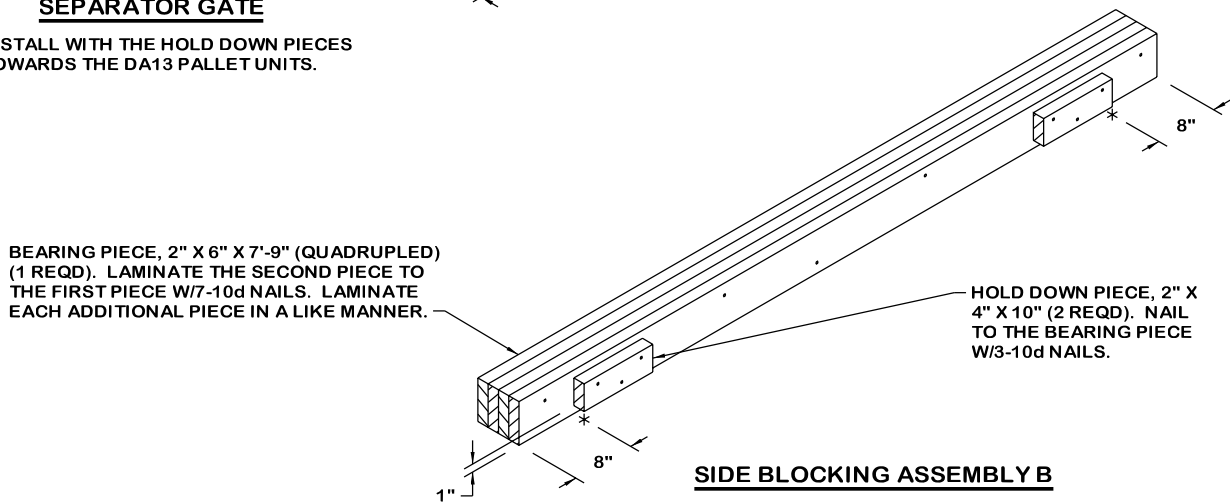

SIDE BLOCKING ASSEMBLY B

INSTALL WITH THE HOLD DOWN PIECES TOWARDS THE LADING.