

[Handwritten Signature]

DATE 5/22/05

APPENDIX 36A

LOADING AND BRACING PROCEDURES FOR STRATEGIC CONFIGURED LOAD (SCL) ON CONTAINER ROLL IN/OUT PLATFORM (CROP)

SCL #36A - 155MM HERA M549A1

INDEX

| <u>ITEM</u> | <u>PAGE(S)</u> |
|---|----------------|
| TYPICAL LOADING PROCEDURES - - - - - | 2 |
| GENERAL NOTES AND SEQUENTIAL LOADING PROCEDURES - - - - - | 3 |
| PALLET UNIT DETAILS - - - - - | 4-5 |
| DETAILS - - - - - | 5-6 |

NOTICE: THIS APPENDIX CANNOT STAND ALONE BUT MUST BE USED IN CONJUNCTION WITH THE BASIC CROP OUTLOADING PROCEDURES DRAWING 19-48-4905-CA17Q6.

- LOADING AND BRACING SPECIFICATIONS SET FORTH WITHIN THIS DRAWING ARE APPLICABLE TO LOADS THAT ARE TO BE SHIPPED BY TRAILER/CONTAINER-ON-FLATCAR (T/COFC) RAIL CARRIER SERVICE. THESE SPECIFICATIONS MAY ALSO BE USED FOR LOADS THAT ARE TO BE MOVED BY MOTOR OR WATER CARRIERS.

U.S. ARMY MATERIEL COMMAND DRAWING

| | | | | | |
|---|--|--------------------------------|------------------|--------------|--------|
| APPROVED, U.S. ARMY FIELD SUPPORT COMMAND <i>[Handwritten Signature]</i> | CAUTION: VERIFY PRIOR TO USE AT WWW.DAC.ARMY.MIL THAT THIS IS THE MOST CURRENT VERSION OF THIS DOCUMENT. THIS IS PAGE 1 OF 6. | | | | |
| | DO NOT SCALE | | MAY 2005 | | |
| APPROVED BY ORDER OF COMMANDING GENERAL, U.S. ARMY MATERIEL COMMAND <i>[Handwritten Signature]</i> U.S. ARMY DEFENSE AMMUNITION CENTER | ENGINEER OR TECHNICIAN | BASIC REV. | LAURA A. FIEFFER | | |
| | TRANSPORTATION ENGINEERING DIVISION | <i>[Handwritten Signature]</i> | | | |
| | VALIDATION ENGINEERING DIVISION | TESTED | CLASS | DIVISION | |
| | ENGINEERING DIRECTORATE | FILE | 19 | 48 | |
| | | DRAWING | FILE | 4905/ 36A | CA17Q6 |

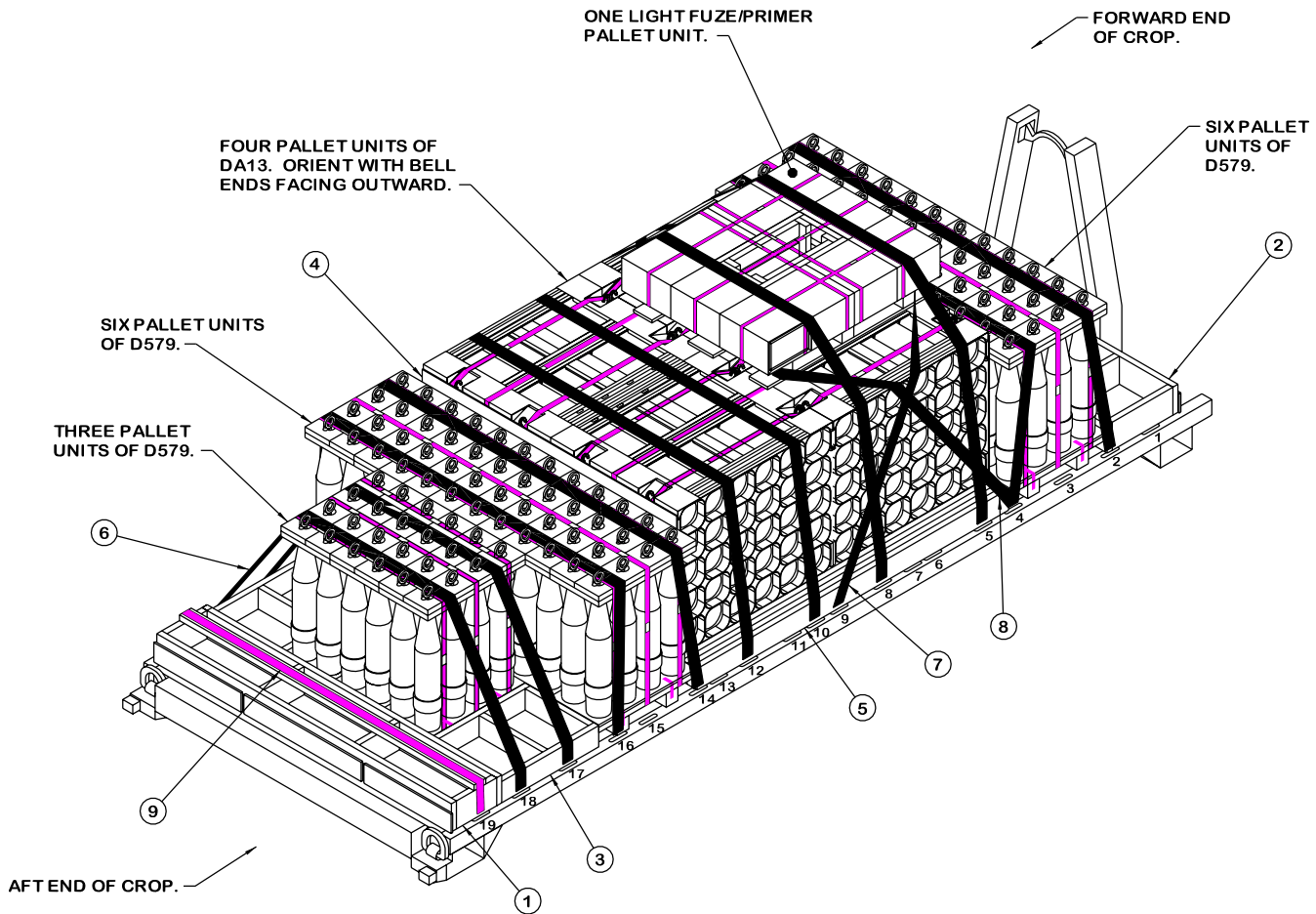

ISOMETRIC VIEW

(KEY NUMBERS CONTINUED)

- ⑦ FORWARD END RESTRAINT STRAP, 3-INCH WIDE WEB STRAP TIEDOWN ASSEMBLY FOR CROP (1 REQD). INSTALL THE STRAP FROM THE NINTH TIEDOWN ANCHOR ON ONE SIDE OF THE CROP, OVER THE DA13 PALLET UNIT, AROUND FORWARD PALLET POSTS OF THE LIGHT FUZE/PRIMER PALLET UNIT, AND BACK DOWN OVER THE DA13 PALLET UNIT TO THE NINTH TIEDOWN ANCHOR ON THE OPPOSITE SIDE OF THE CROP. ALIGN SCUFF SLEEVES OVER ALL SHARP EDGES AND FIRMLY TENSION STRAP. SEE GENERAL NOTE "G" ON PAGE 3.
- ⑧ AFT END RESTRAINT STRAP, 3-INCH WIDE WEB STRAP TIEDOWN ASSEMBLY FOR CROP (1 REQD). INSTALL THE STRAP FROM THE FOURTH TIEDOWN ANCHOR ON ONE SIDE OF THE CROP, OVER THE DA13 PALLET UNIT, AROUND THE AFT PALLET POSTS OF THE LIGHT FUZE/PRIMER PALLET UNIT, AND BACK DOWN OVER THE DA13 PALLET UNIT TO THE FOURTH TIEDOWN ANCHOR ON THE OPPOSITE SIDE OF THE CROP. ALIGN SCUFF SLEEVES OVER ALL SHARP EDGES AND FIRMLY TENSION STRAP. SEE GENERAL NOTE "G" ON PAGE 3.
- ⑨ RETAINER STRAP, 2" WIDE WEB STRAP TIEDOWN ASSEMBLY (1 REQD). INSTALL TO EXTEND FROM THE NINETEENTH TIEDOWN RING ON ONE SIDE OF THE CROP, OVER THE TOP OF THE STRAPPING BOARD OF THE AFT FILLER ASSEMBLY, TO THE NINETEENTH TIEDOWN RING ON THE OPPOSITE SIDE OF THE CROP. POSITION SCUFF SLEEVES OVER ALL SHARP EDGES AND FIRMLY TENSION STRAP. SEE GENERAL NOTE "G" ON PAGE 3.

KEY NUMBERS

- ① AFT FILLER ASSEMBLY (1 REQD). SEE DETAIL ON PAGE 5. CENTER AGAINST AFT CROP END GATE AND, AFTER THE PALLET UNITS ARE LOADED, NAIL W/2-12d NAILS THRU THE SLOTS IN THE AFT CROP END GATE INTO THE AFT FILLER ASSEMBLY, LEAVING THE NAIL HEADS PROTRUDING THRU THE SLOTS TO PROVIDE LATERAL RESTRAINT.
- ② FORWARD FILLER ASSEMBLY (1 REQD). SEE DETAIL ON PAGE 6. CENTER AGAINST FORWARD CROP END GATE AND, AFTER THE PALLET UNITS ARE LOADED, NAIL W/2-12d NAILS THRU THE HOLES IN THE FORWARD CROP END GATE INTO THE FORWARD FILLER ASSEMBLY, LEAVING THE NAIL HEADS PROTRUDING THRU THE HOLES TO PROVIDE LATERAL AND VERTICAL RESTRAINT.
- ③ SIDE BLOCKING ASSEMBLY A (2 REQD). SEE THE DETAIL ON PAGE 6. INSTALL ONE ON EACH SIDE OF THE CROP ADJACENT TO THE ROW OF THREE D579 PALLET UNITS. AFTER THE HOLD-DOWN STRAPS ARE INSTALLED, NAIL THROUGH THE STRAP ATTACHMENT SLOTS OF TWO HOLD-DOWN STRAPS INTO SIDE BLOCKING W/1-10d PARTIALLY DRIVEN NAIL AND BEND OVER SIDE OF HOOK.
- ④ SEPARATOR GATE (2 REQD). SEE THE DETAIL ON PAGE 6.
- ⑤ SIDE BLOCKING ASSEMBLY B (2 REQD). SEE THE DETAIL ON PAGE 6. INSTALL ONE ON EACH SIDE OF THE CROP ADJACENT TO THE DA13 PALLET UNITS. AFTER THE HOLD-DOWN STRAPS ARE INSTALLED, NAIL THROUGH THE STRAP ATTACHMENT SLOTS OF TWO HOLD-DOWN STRAPS (ONE AT EACH END OF THE ASSEMBLY) INTO SIDE BLOCKING W/1-10d PARTIALLY DRIVEN NAIL AND BEND OVER SIDE OF HOOK.
- ⑥ HOLD-DOWN STRAP, 3-INCH WIDE WEB STRAP TIEDOWN ASSEMBLY FOR CROP (10 REQD). INSTALL EACH HOLD-DOWN STRAP TO EXTEND FROM THE DESIGNATED TIEDOWN ANCHOR ON ONE SIDE OF CROP, OVER THE TOP OF THE PALLET UNITS, TO THE CORRESPONDING TIEDOWN ANCHOR ON THE OPPOSITE SIDE OF THE CROP. ALIGN SCUFF SLEEVES OVER ALL SHARP EDGES AND FIRMLY TENSION STRAP. SEE GENERAL NOTE "G" ON PAGE 3.

(CONTINUED AT LEFT)

RECOMMENDED SEQUENTIAL PROCEDURES

1. PREFABRICATE THE AFT FILLER ASSEMBLY, THE FORWARD FILLER ASSEMBLY, TWO SIDE BLOCKING ASSEMBLIES "A", TWO SIDE BLOCKING ASSEMBLIES "B", AND TWO SEPARATOR GATES.
2. INSTALL THE AFT FILLER ASSEMBLY.
3. LOAD ONE ROW OF THREE PALLET UNITS OF D579 AGAINST THE AFT END FILLER ASSEMBLY, CENTERING THE ROW LATERALLY ON THE CROP.
4. LOAD ONE ROW OF SIX PALLET UNITS OF D579 AGAINST THE FIRST D579 PALLET UNITS, CENTERING THE ROW LATERALLY ON THE CROP.
5. INSTALL ONE SEPARATOR GATE, WITH THE HOLD-DOWN PIECES AWAY FROM THE D579 PALLET UNITS.
6. LOAD TWO ROWS OF TWO PALLET UNITS OF DA13 AGAINST THE D579 PALLET UNITS, CENTERING THE ROWS LATERALLY ON THE CROP.
7. INSTALL ONE SEPARATOR GATE, WITH THE HOLD-DOWN PIECES UNDER THE DA13 PALLET UNITS.
8. LOAD ONE ROW OF SIX PALLET UNITS OF D579 AGAINST THE DA13 PALLET UNITS, CENTERING THE ROW LATERALLY ON THE CROP.
9. INSTALL THE FORWARD FILLER ASSEMBLY.
10. LOAD ONE LIGHT FUZE/PRIMER PALLET UNIT ON TOP OF THE SECOND ROW OF DA13 PALLET UNITS, ALIGNING WITH THE STRONG POINTS OF AND CENTERING ON THE DA13 ROW.
11. INSTALL THE TWO SIDE BLOCKING ASSEMBLIES "A", ONE ON EITHER SIDE OF THE THREE D579 PALLET UNITS.
12. INSTALL THE TWO SIDE BLOCKING ASSEMBLIES "B", ONE ON EITHER SIDE OF THE DA13 PALLET UNITS.
13. INSTALL 10 WEB STRAP TIEDOWN ASSEMBLIES AS DELINEATED IN KEY NUMBER ⑥.
14. INSTALL THE FORWARD END RESTRAINT STRAP AS DELINEATED IN KEY NUMBER ⑦.
15. INSTALL THE AFT END RESTRAINT STRAP AS DELINEATED IN KEY NUMBER ⑧.
16. NAIL THROUGH THE STRAP ATTACHMENT SLOT OF A HOLD-DOWN STRAP INTO EACH END OF THE SIDE BLOCKING ASSEMBLIES W1-10d PARTIALLY DRIVEN NAIL AND BEND OVER SIDE OF HOOK.
17. INSTALL RETAINER STRAP AS DELINEATED IN KEY NUMBER ⑨.
18. NAIL TWO 12d RETAINING NAILS THRU THE SLOTS IN THE AFT CROP END GATE AS DELINEATED IN KEY NUMBER ①.
19. NAIL THE TWO REMAINING 12d RETAINING NAILS THRU THE HOLES IN THE FORWARD CROP END GATE AS DELINEATED IN KEY NUMBER ②.

GENERAL NOTES

- A. THIS APPENDIX CANNOT STAND ALONE BUT MUST BE USED IN CONJUNCTION WITH THE BASIC LOADING PROCEDURES DRAWING 19-48-4905-CA17Q6. TO PRODUCE AN APPROVED LOAD, ALL PERTINENT PROCEDURES, SPECIFICATIONS AND CRITERIA SET FORTH WITHIN THE BASIC DRAWING WILL APPLY TO THE PROCEDURES DELINEATED IN THIS APPENDIX. ANY EXCEPTIONS TO THE BASIC PROCEDURES ARE SPECIFIED IN THIS APPENDIX.
- B. THE OUTLOADING PROCEDURES DEPICTED IN THIS DRAWING ARE APPLICABLE TO LOADS OF SCL #36A. SEE PAGES 4 AND 5 FOR DETAILS OF THE PALLET UNITS. AN M3A1 (HYUNDAI) CROP IS SHOWN AS TYPICAL. OTHER MANUFACTURER'S CROPS CAN BE USED FOR THE LOAD SHOWN ON PAGE 2. THE SEQUENTIAL LOADING PROCEDURES DEPICTED AT LEFT DESCRIBE THE SEQUENCE USED TO LOAD AN M3A1 CROP. FOR AN M3 (SUMMA) CROP, SEQUENTIAL LOADING PROCEDURES 2 THROUGH 9 MUST BE REVERSED. ACTUAL CROP CONFIGURATION WILL DETERMINE WHETHER THE SEQUENTIAL LOADING STARTS AT THE AFT OR THE FORWARD END OF THE CROP.
- C. THE LOADING PROCEDURES DEPICTED HEREIN MAY ALSO BE USED FOR OUTLOADING SIMILAR SCL LOADS WHEN IDENTIFIED BY DIFFERENT NATIONAL STOCK NUMBERS (NSN) THAN WHAT IS SHOWN ON PAGE 4, PROVIDED THE OVERALL PALLET UNIT DIMENSIONS DO NOT VARY FROM WHAT IS DELINEATED HEREIN.
- D. DIMENSIONS, CUBE AND WEIGHT OF THE PALLET UNITS WILL VARY SLIGHTLY DEPENDING UPON THE ACTUAL DIMENSIONS OF THE BOXES AND THE WEIGHT OF THE SPECIFIC ITEM BEING UNITIZED.
- E. ALTERNATE NSN/DODIC COMBINATIONS ARE SHOWN IN THE CHART ON PAGE 4. THESE ALTERNATES MAY BE SUBSTITUTED FOR SOME OR ALL THE DEPICTED NSN/DODICS IF NECESSARY DUE TO THE ITEMS OR QUANTITIES ON HAND.
- F. DIMENSIONS GIVEN FOR DUNNAGE ASSEMBLIES WILL BE FIELD CHECKED PRIOR TO THEIR ASSEMBLY. PALLET UNITS MUST FIT SNUGLY AGAINST THE DUNNAGE ASSEMBLIES. THIS GUIDANCE MUST BE APPLIED PRIOR TO BEGINNING AN OUTLOADING OPERATION. ALSO, DUE TO VARIATION OF PALLET UNIT DIMENSIONS, ADJUSTMENTS MAY BE REQUIRED AS TO THE LOCATION OF CERTAIN PIECES ON DUNNAGE ASSEMBLIES.
- G. ALL WEB STRAP TIEDOWN ASSEMBLIES MUST HAVE THE EXCESS LENGTH OF THE STRAP SECURED. ROLL UP AND BUNDLE THE EXCESS LENGTH OF WEB STRAP, SECURING WITH CABLE TIES. SEE THE "STRAP END SECUREMENT" DETAIL AND GENERAL NOTE "K.12" IN THE BASIC PROCEDURE DRAWING 19-48-4905-CA17Q6.
- H. UNUSED WEB STRAP TIEDOWN ASSEMBLIES MUST BE SECURED AS DELINEATED IN GENERAL NOTE "K.13" IN THE BASIC PROCEDURES DRAWING 19-48-4905-CA17Q6.
- J. CONVERSION TO METRIC EQUIVALENTS: DIMENSIONS WITHIN THIS DOCUMENT ARE EXPRESSED IN INCHES, AND WEIGHTS ARE EXPRESSED IN POUNDS. WHEN NECESSARY, THE METRIC EQUIVALENTS MAY BE COMPUTED ON THE BASIS OF ONE INCH EQUALS 25.4MM AND ONE POUND EQUALS 0.454 KG.

BILL OF MATERIAL

| LUMBER | LINEAR FEET | BOARD FEET |
|-------------------------------|------------------|----------------|
| 2" X 3" (ACTUAL) | 5 | 3 |
| 2" X 4" | 14 | 10 |
| 2" X 6" | 82 | 82 |
| 2" X 8" | 41 | 55 |
| NAILS | NO. REQD | POUNDS |
| 6d (2") | 12 | 1/4 |
| 10d (3") | 178 | 2-3/4 |
| 12d (3-1/4") | 4 | 1/4 |
| PLYWOOD, 1/4" - - - | 44.33 SQ FT REQD | - - 30-1/2 LBS |
| 2" WEB STRAP TIEDOWN ASSY - - | 1 REQD | - - - 6 LBS |

LOAD AS SHOWN

| ITEM | QUANTITY | WEIGHT (APPROX) |
|--------------------------|--------------|----------------------|
| D579 PALLET UNIT - - - - | 15 - - - - - | 12, 225 LBS |
| DA13 PALLET UNIT - - - - | 4 - - - - - | 7, 340 LBS |
| LIGHT FUZE/PRIMER | | |
| PALLET UNIT - - - - - | 1 - - - - - | 541 LBS |
| DUNNAGE - - - - - | | 335 LBS |
| CROP - - - - - | | 3, 800 LBS |
| TOTAL WEIGHT - - - - - | | 24, 241 LBS (APPROX) |

SCL #36A COMPOSITION CHART

| DODIC | NSN | NOMENCLATURE | UNIT DWG | REQD | UNITS REQD | HC |
|--------|------------------|--|-----------|------|------------|----------|
| D579 | 1320-01-047-6009 | PROJ, 155MM HERA M549A1 | 9327883 | 120 | 15 PALLETS | 1. 1D |
| DA13 | 1320-01-457-4063 | MODULAR ARTILLERY CHARGE SYSTEM (MACS), M232 | 4326/50A | 600 | 4 PALLETS | 1. 3C |
| N290 * | 1390-01-283-6532 | FUZE, ELECTRONIC TIME W/BOOSTER M767 | 4116/156S | 48 | 3 BOXES | 1. 2. 2D |
| N291 ^ | 1390-01-309-6452 | FUZE, PROXIMITY W/BOOSTER M732A2 | 4116/156 | 48 | 3 BOXES | 1. 2. 2D |
| N340 * | 1390-01-132-7481 | FUZE, PD W/O BOOSTER M739A1 | 4116/156S | 48 | 3 BOXES | 1. 2. 2D |
| N523 | 1390-01-481-2024 | PRIMER, PERCUSSION M82 | 4116/158G | 200 | 1 BOX | 1. 4S |

NOTE: THE DODICS LISTED BELOW MAY BE USED AS ALTERNATES FOR THE DODICS WITH MATCHING SYMBOLS SHOWN ABOVE IF THE QUANTITY OF THE DODICS SHOWN ABOVE IS INSUFFICIENT.

| | | | | | | |
|--------|------------------|--------------------------------|-----------|--|--|----------|
| N464 ^ | 1390-01-202-1710 | FUZE, PROXIMITY W/BOOSTER M732 | 4116/156G | | | 1. 2. 2D |
| NA08 * | 1390-01-436-2308 | FUZE, MOFA W/BOOSTER M773 | 4116/156 | | | 1. 2. 2D |

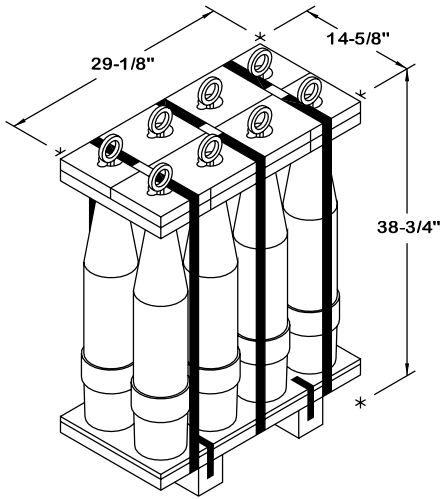

D579 PALLET UNIT DETAIL

| | | |
|--------------------------|-------|--------------------|
| 8 155MM CTG @ 96-7/8 LBS | ----- | 775 LBS (APPROX) |
| DUNNAGE AND PALLET | ----- | 40 LBS |
| <hr/> | | |
| TOTAL WEIGHT | ----- | 815 LBS (APPROX) |
| CUBE | ----- | 9.6 CU FT (APPROX) |

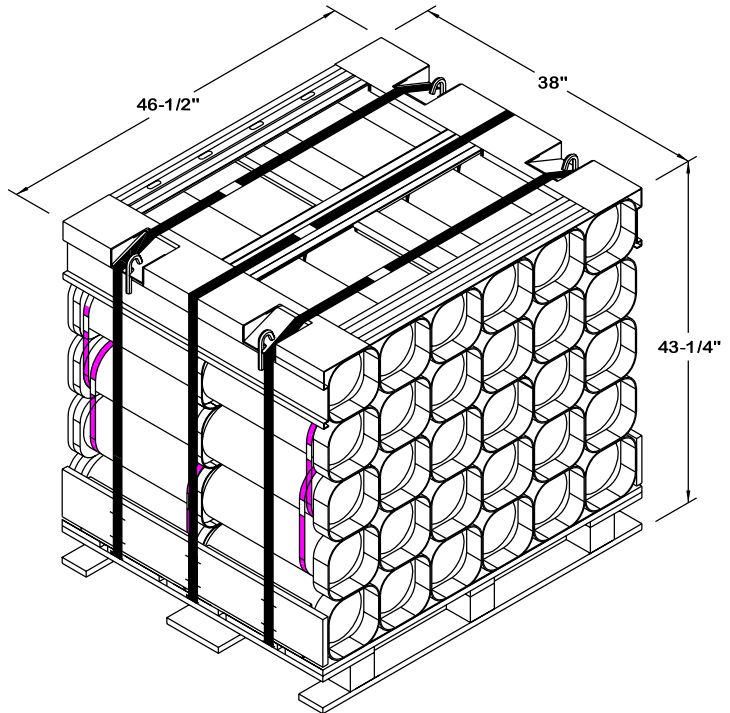

DA13 PALLET UNIT DETAIL

| | | |
|---|-------|---------------------|
| 30 CONTAINERS OF MACS PROPELLING CHARGES (5 PER CONTAINER) @ 55 LBS | ----- | 1,650 LBS (APPROX) |
| DUNNAGE | ----- | 110 LBS |
| PALLET | ----- | 75 LBS |
| <hr/> | | |
| TOTAL WEIGHT | ----- | 1,835 LBS (APPROX) |
| CUBE | ----- | 44.3 CU FT (APPROX) |

INDICATES ONE N523 BOX.

FILLER ASSEMBLY
(1 REQD). SEE THE
DETAIL BELOW.

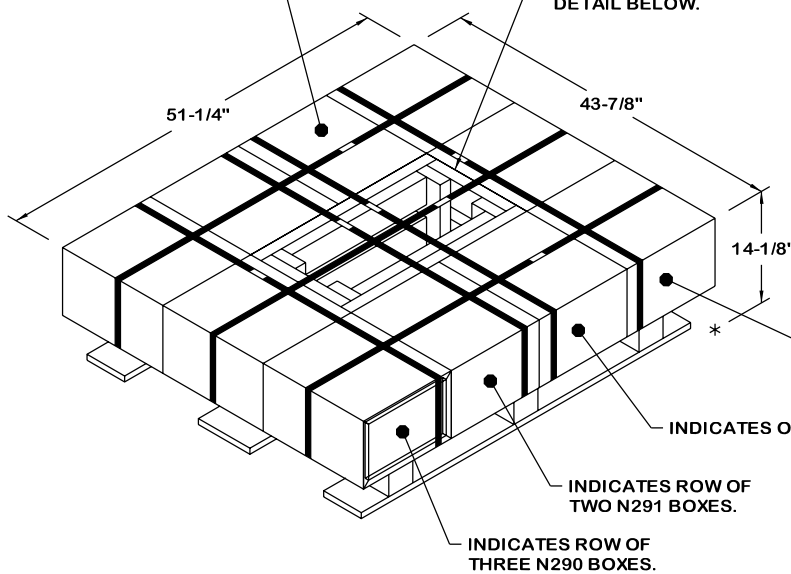

THE LIGHT FUZE/PRIMER PALLET UNIT SHOULD BE CONSTRUCTED IAW AMC DRAWING 19-48-4116/156S-20PA1002 WITH THE FOLLOWING CHANGES:

1. ELIMINATE TWO LAYER OF BOXES (24 BOXES).
2. LOAD THE 10 BOXES OF FUZES AND PRIMERS.
3. INSTALL THE FILLER ASSEMBLY.
4. REDUCE THE TIEDOWN STRAP LENGTH TO 9'-10".
5. REDUCE THE LOAD STRAP LENGTH TO 11'-1".

* INDICATES ROW OF THREE N340 BOXES.

INDICATES ONE N291 BOX.

INDICATES ROW OF TWO N291 BOXES.

INDICATES ROW OF THREE N290 BOXES.

LIGHT FUZE/PRIMER PALLET UNIT DETAIL

| | | |
|--|----|------------------|
| 3 BOXES OF N290 (16 PER BOX) AT 42 LBS | -- | 126 LBS (APPROX) |
| 3 BOXES OF N291 (16 PER BOX) AT 42 LBS | -- | 126 LBS (APPROX) |
| 3 BOXES OF N340 (16 PER BOX) AT 46 LBS | -- | 138 LBS (APPROX) |
| 1 BOX OF N523 (200 PER BOX) AT 34 LBS | -- | 34 LBS (APPROX) |
| DUNNAGE | -- | 37 LBS |
| PALLET | -- | 80 LBS |

TOTAL WEIGHT ----- 541 LBS (APPROX)
CUBE ----- 18.4 CU FT (APPROX)

STRAPPING BOARD, 2" X 4" X 7'-4"
(1 REQD). NAIL TO THE STRUTS
W/2-10d NAILS AT EACH JOINT.

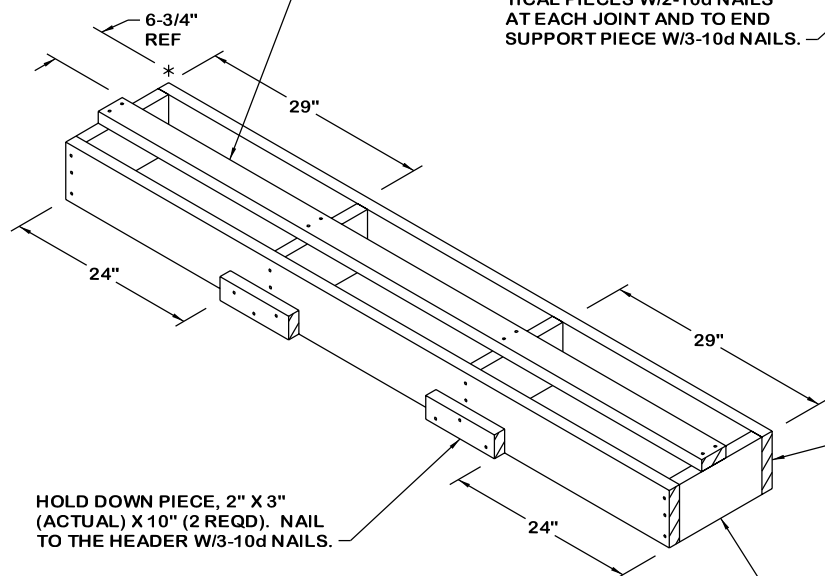

AFT FILLER ASSEMBLY

INSTALL WITH THE HOLD DOWN PIECES TOWARDS THE LADING. ENSURE THAT THE STRAPPING BOARD IS IN ALIGNMENT WITH THE NINETEENTH TIEDOWN ANCHOR.

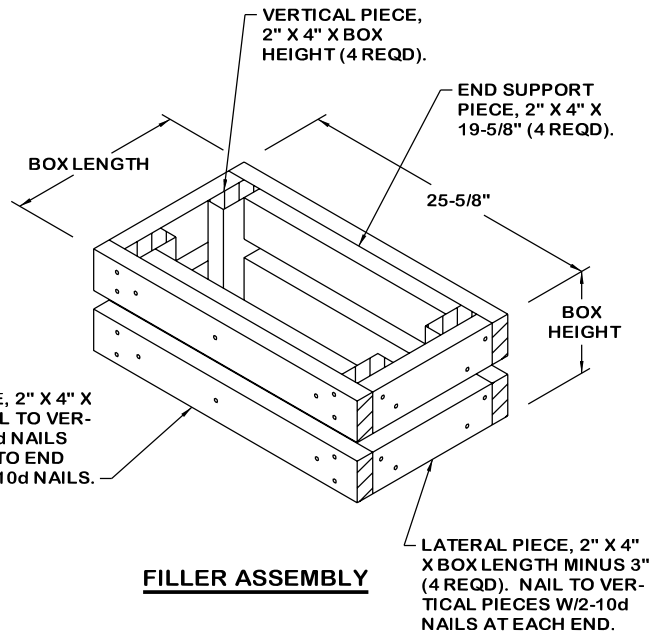

FILLER ASSEMBLY

HEADER, 2" X 8" X 7'-4"
(2 REQD). NAIL TO THE STRUTS W/3-10d
NAILS AT EACH JOINT.

STRUT, 2" X 8"
X 12" (4 REQD).

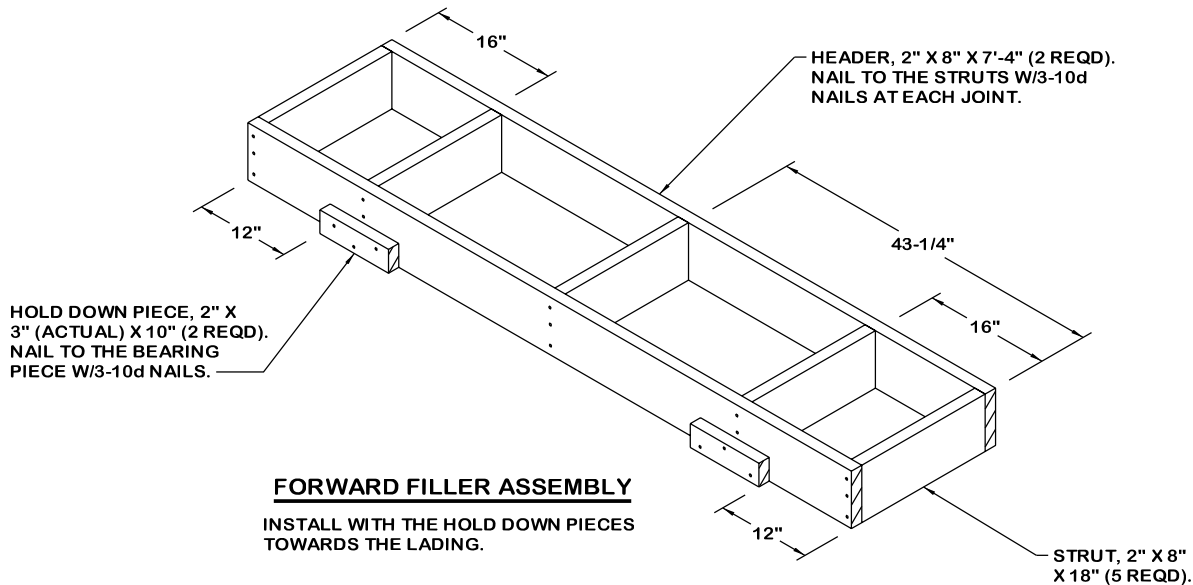

FORWARD FILLER ASSEMBLY

INSTALL WITH THE HOLD DOWN PIECES
TOWARDS THE LADING.

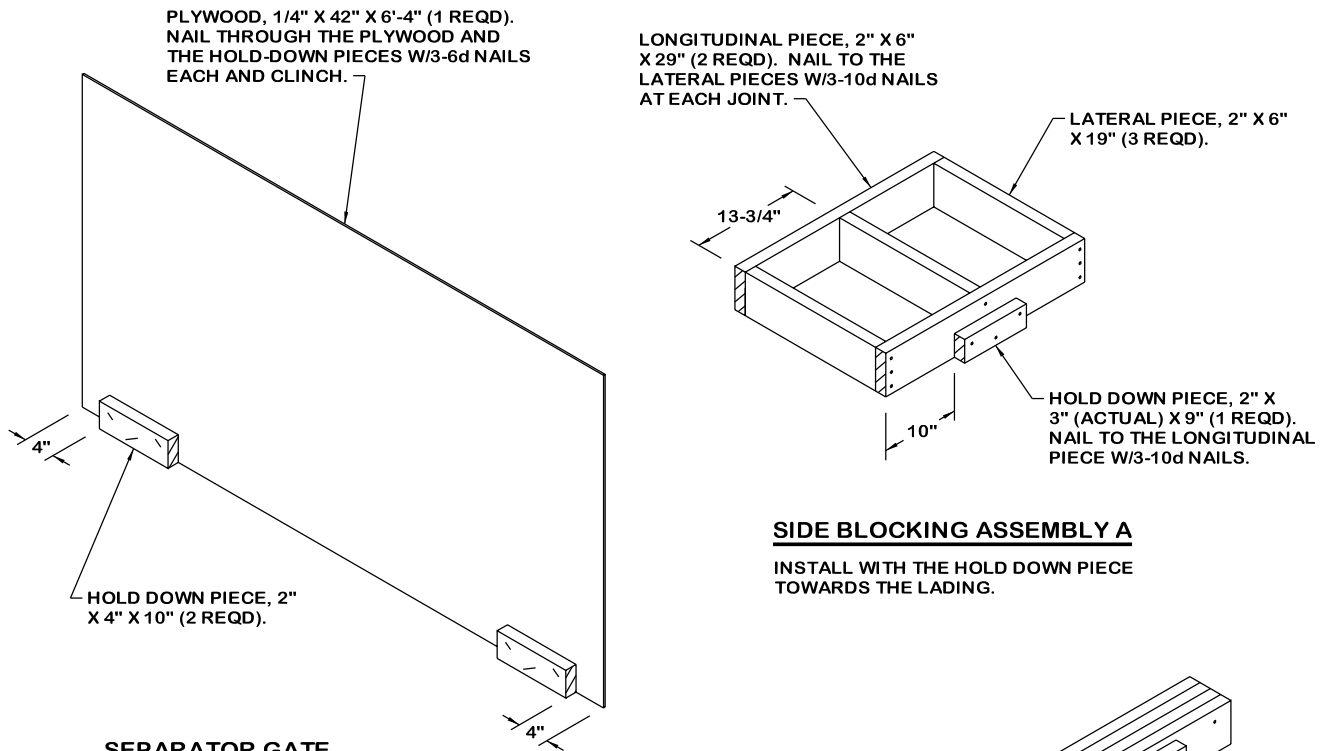

SEPARATOR GATE

INSTALL WITH THE HOLD DOWN PIECES
TOWARDS THE DA13 PALLET UNITS.

SIDE BLOCKING ASSEMBLY A

INSTALL WITH THE HOLD DOWN PIECE
TOWARDS THE LADING.

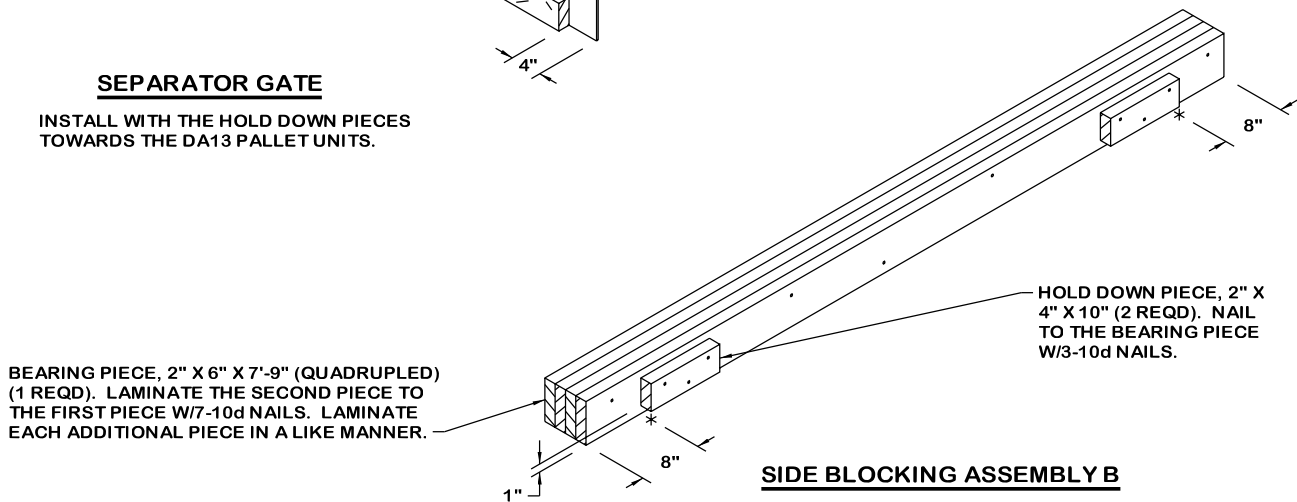

SIDE BLOCKING ASSEMBLY B

INSTALL WITH THE HOLD DOWN PIECES
TOWARDS THE LADING.