

APPENDIX 34A

DATE _____

LOADING AND BRACING PROCEDURES FOR STRATEGIC CONFIGURED LOAD (SCL) ON CONTAINER ROLL IN/OUT PLATFORM (CROP)

SCL #34A - 155MM RAAM-S M741A1



INDEX

| ITEM | PAGE(S) |
|---|---------|
| TYPICAL LOADING PROCEDURES - - - - - | 2 |
| GENERAL NOTES AND SEQUENTIAL LOADING PROCEDURES - - - - - | 3 |
| PALLET UNIT DETAILS - - - - - | 4-5 |
| DETAILS - - - - - | 6-8 |

NOTICE: THIS APPENDIX CANNOT STAND ALONE BUT MUST BE USED IN CONJUNCTION WITH THE BASIC CROP OUTLOADING PROCEDURES DRAWING 19-48-4905-CA17Q6.

- LOADING AND BRACING SPECIFICATIONS SET FORTH WITHIN THIS DRAWING ARE APPLICABLE TO LOADS THAT ARE TO BE SHIPPED BY TRAILER/CONTAINER-ON-FLATCAR (T/COFC) RAIL CARRIER SERVICE. THESE SPECIFICATIONS MAY ALSO BE USED FOR LOADS THAT ARE TO BE MOVED BY MOTOR OR WATER CARRIERS.

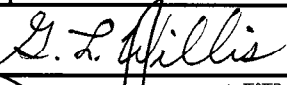
U.S. ARMY MATERIEL COMMAND DRAWING

| | | | | | |
|---|--|--|--|------------------|----------|
| APPROVED, U.S. ARMY FIELD SUPPORT COMMAND | | CAUTION: VERIFY PRIOR TO USE AT WWW.DAC.ARMY.MIL THAT THIS IS THE MOST CURRENT VERSION OF THIS DOCUMENT. THIS IS PAGE 1 OF 8. | | | |
|  | | DO NOT SCALE | | MAY 2005 | |
| | | ENGINEER OR TECHNICIAN | BASIC REV. | LAURA A. FIEFFER | |
| APPROVED BY ORDER OF COMMANDING GENERAL, U.S. ARMY MATERIEL COMMAND | | TRANSPORTATION ENGINEERING DIVISION |  | | |
|  | | VALIDATION ENGINEERING DIVISION | TESTED | CLASS | DIVISION |
| | | ENGINEERING DIRECTORATE |  | 19 | 48 |
| U.S. ARMY DEFENSE AMMUNITION CENTER | | | | DRAWING | FILE |
| | | | | 4905/ 34A | CA17Q6 |

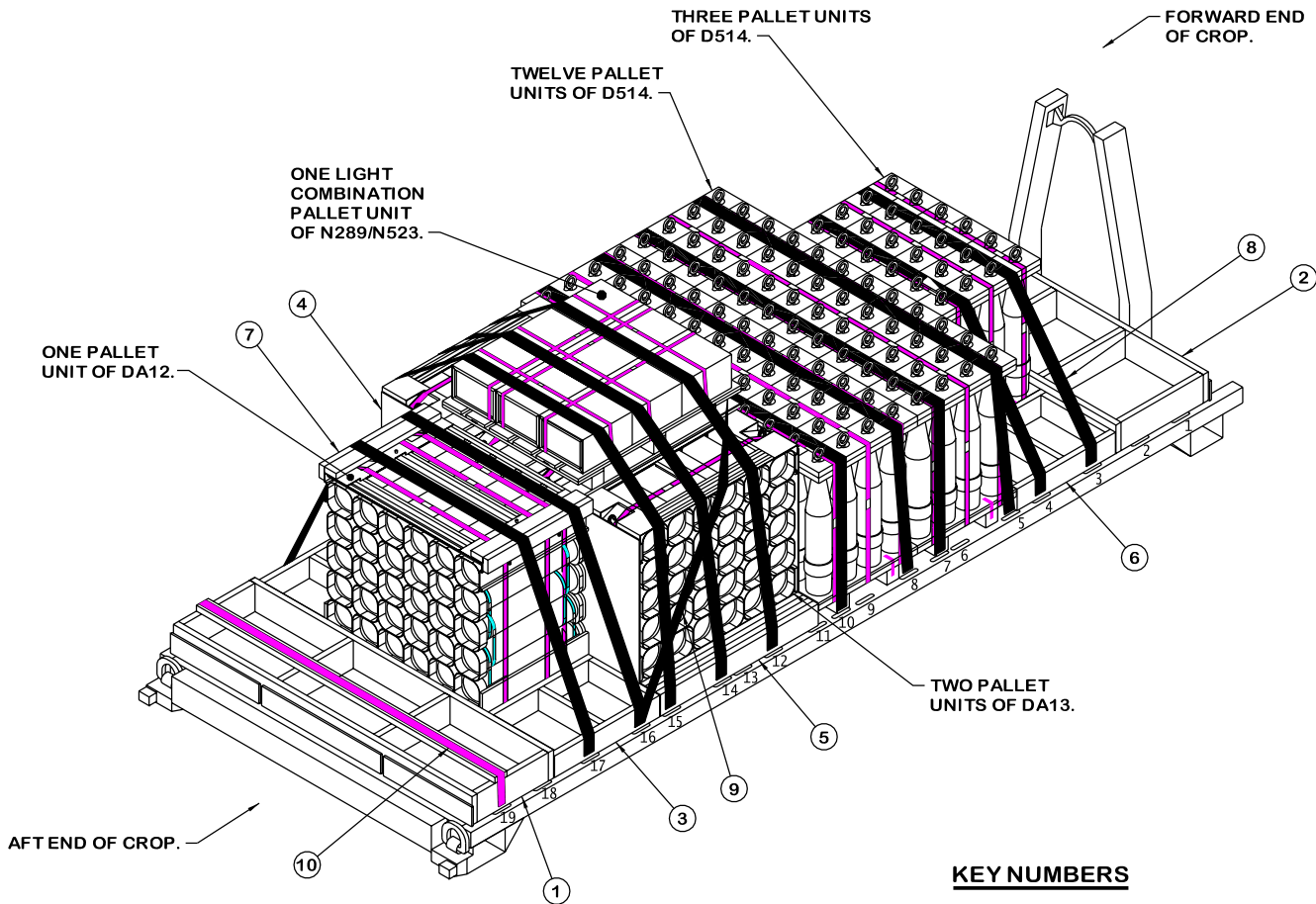

ISOMETRIC VIEW

(KEY NUMBERS CONTINUED)

- ⑧ HOLD-DOWN STRAP, 3-INCH WIDE WEB STRAP TIEDOWN ASSEMBLY FOR CROP (11 REQD). INSTALL EACH HOLD-DOWN STRAP TO EXTEND FROM THE DESIGNATED TIEDOWN ANCHOR ON ONE SIDE OF CROP, OVER THE TOP OF THE PALLET UNIT(S), TO THE CORRESPONDING TIEDOWN ANCHOR ON THE OPPOSITE SIDE OF THE CROP. ALIGN SCUFF SLEEVES OVER ALL SHARP EDGES AND FIRMLY TENSION STRAP. SEE GENERAL NOTE "G" ON PAGE 3.
- ⑨ FORWARD END RESTRAINT STRAP, 3-INCH WIDE WEB STRAP TIEDOWN ASSEMBLY FOR CROP (1 REQD). INSTALL THE STRAP FROM THE SIXTEENTH TIEDOWN ANCHOR ON ONE SIDE OF THE CROP, OVER A DA13 PALLET UNIT, AROUND FORWARD PALLET POSTS OF THE LIGHT COMBINATION N289/N523 PALLET UNIT, AND BACK DOWN OVER A DA13 PALLET UNIT TO THE SIXTEENTH TIEDOWN ANCHOR ON THE OPPOSITE SIDE OF THE CROP. ALIGN SCUFF SLEEVES OVER ALL SHARP EDGES AND FIRMLY TENSION STRAP. SEE GENERAL NOTE "G" ON PAGE 3.
- ⑩ RETAINER STRAP, 2" WIDE WEB STRAP TIEDOWN ASSEMBLY (1 REQD). INSTALL TO EXTEND FROM THE NINETEENTH TIEDOWN RING ON ONE SIDE OF THE CROP, OVER THE TOP OF THE STRAPPING BOARD OF THE AFT FILLER ASSEMBLY, TO THE NINETEENTH TIEDOWN RING ON THE OPPOSITE SIDE OF THE CROP. POSITION SCUFF SLEEVES OVER ALL SHARP EDGES AND FIRMLY TENSION STRAP. SEE GENERAL NOTE "G" ON PAGE 3.

KEY NUMBERS

- ① AFT FILLER ASSEMBLY (1 REQD). SEE DETAIL ON PAGE 6. CENTER AGAINST AFT CROP END GATE AND, AFTER THE PALLET UNITS ARE LOADED, NAIL W/2-12d NAILS THRU THE SLOTS IN THE AFT CROP END GATE INTO THE AFT FILLER ASSEMBLY, LEAVING THE NAIL HEADS PROTRUDING THRU THE SLOTS TO PROVIDE LATERAL RESTRAINT.
- ② FORWARD FILLER ASSEMBLY (1 REQD). SEE DETAIL ON PAGE 6. CENTER AGAINST FORWARD CROP END GATE AND, AFTER THE PALLET UNITS ARE LOADED, NAIL W/2-12d NAILS THRU THE HOLES IN THE FORWARD CROP END GATE INTO THE FORWARD FILLER PIECES, LEAVING THE NAIL HEADS PROTRUDING THRU THE HOLES TO PROVIDE LATERAL AND VERTICAL RESTRAINT.
- ③ SIDE BLOCKING ASSEMBLY A (2 REQD). SEE THE DETAIL ON PAGE 7. INSTALL ONE ON EACH SIDE OF THE CROP ADJACENT TO THE DA12 PALLET UNIT. AFTER THE HOLD-DOWN STRAPS ARE INSTALLED, NAIL THROUGH THE STRAP ATTACHMENT SLOTS OF TWO HOLD-DOWN STRAPS INTO SIDE BLOCKING W/1-10d PARTIALLY DRIVEN NAIL AND BEND OVER SIDE OF HOOK.
- ④ SEPARATOR GATE (2 REQD). SEE THE DETAIL ON PAGE 8.
- ⑤ SIDE BLOCKING ASSEMBLY B (2 REQD). SEE THE DETAIL ON PAGE 7. INSTALL ONE ON EACH SIDE OF THE CROP ADJACENT TO THE DA13 PALLET UNITS. AFTER THE HOLD-DOWN STRAPS ARE INSTALLED, NAIL THROUGH THE STRAP ATTACHMENT SLOTS OF TWO HOLD-DOWN STRAPS (ONE AT EACH END OF THE ASSEMBLY) INTO SIDE BLOCKING W/1-10d PARTIALLY DRIVEN NAIL AND BEND OVER SIDE OF HOOK.
- ⑥ SIDE BLOCKING ASSEMBLY C (2 REQD). SEE THE DETAIL ON PAGE 7. INSTALL ONE ON EACH SIDE OF THE CROP ADJACENT TO THE ROW OF THREE D514 PALLET UNITS. AFTER THE HOLD-DOWN STRAPS ARE INSTALLED, NAIL THROUGH THE STRAP ATTACHMENT SLOTS OF TWO HOLD-DOWN STRAPS INTO SIDE BLOCKING W/1-10d PARTIALLY DRIVEN NAIL AND BEND OVER SIDE OF HOOK.
- ⑦ STRAPPING BOARD ASSEMBLY (2 REQD). SEE THE DETAIL ON PAGE 8. INSTALL ON THE EDGES OF THE DA12 PALLET UNIT.

(CONTINUED AT LEFT)

RECOMMENDED SEQUENTIAL PROCEDURES

1. PREFABRICATE THE AFT FILLER ASSEMBLY, THE FORWARD FILLER ASSEMBLY, TWO SIDE BLOCKING ASSEMBLIES "A", TWO SIDE BLOCKING ASSEMBLIES "B", TWO SIDE BLOCKING ASSEMBLIES "C", TWO STRAPPING BOARD ASSEMBLIES, AND TWO SEPARATOR GATES.
2. INSTALL THE AFT FILLER ASSEMBLY.
3. LOAD ONE DA12 PALLET UNIT, CROSSWISE, CENTERING LATERALLY ON THE CROP.
4. INSTALL ONE SEPARATOR GATE, WITH THE HOLD DOWN PIECES AWAY FROM THE DA12 PALLET UNITS.
5. LOAD ONE ROW OF TWO PALLET UNITS OF DA13 AGAINST THE SEPARATOR GATE, CENTERING THE ROW LATERALLY ON THE CROP.
6. INSTALL ONE SEPARATOR GATE, WITH THE HOLD DOWN PIECES UNDER THE DA13 PALLET UNITS.
7. LOAD TWO ROWS OF SIX PALLET UNITS OF D514 AGAINST THE SEPARATOR GATE, CENTERING LATERALLY ON THE CROP.
8. LOAD ONE ROW OF THREE PALLET UNITS OF D514 AGAINST THE D514 PALLET UNITS, CENTERING LATERALLY ON THE CROP.
9. INSTALL THE FORWARD FILLER ASSEMBLY.
10. LOAD ONE LIGHT N289/N523 COMBINATION PALLET UNIT ON TOP OF THE ROW OF DA13 PALLET UNITS, TIGHT AGAINST THE DA12 PALLET UNIT. CENTER AND ALIGN WITH THE STRONG POINTS OF THE DA13 ROW.
11. INSTALL THE TWO SIDE BLOCKING ASSEMBLIES "A", ONE ON EITHER SIDE OF THE DA12 PALLET UNIT.
12. INSTALL THE TWO SIDE BLOCKING ASSEMBLIES "B", ONE ON EITHER SIDE OF THE DA13 PALLET UNITS.
13. INSTALL THE TWO SIDE BLOCKING ASSEMBLIES "C", ONE ON EITHER SIDE OF THE THREE D514 PALLET UNITS.
14. INSTALL 11 WEB STRAP TIEDOWN ASSEMBLIES AS DELINEATED IN KEY NUMBER ⑧.
15. INSTALL THE FORWARD END RESTRAINT STRAP AS DELINEATED IN KEY NUMBER ⑨.
16. NAIL THROUGH THE STRAP ATTACHMENT SLOT OF A HOLD-DOWN STRAP INTO EACH END OF THE SIDE BLOCKING ASSEMBLIES W1-10d PARTIALLY DRIVEN NAIL AND BEND OVER SIDE OF HOOK.
17. INSTALL RETAINER STRAP AS DELINEATED IN KEY NUMBER ⑩.
18. NAIL TWO 12d RETAINING NAILS THRU THE SLOTS IN THE AFT CROP END GATE AS DELINEATED IN KEY NUMBER ①.
19. NAIL THE TWO REMAINING 12d RETAINING NAILS THRU THE HOLES IN THE FORWARD CROP END GATE AS DELINEATED IN KEY NUMBER ②.

GENERAL NOTES

- A. THIS APPENDIX CANNOT STAND ALONE BUT MUST BE USED IN CONJUNCTION WITH THE BASIC LOADING PROCEDURES DRAWING 19-48-4905-CA17Q6. TO PRODUCE AN APPROVED LOAD, ALL PERTINENT PROCEDURES, SPECIFICATIONS AND CRITERIA SET FORTH WITHIN THE BASIC DRAWING WILL APPLY TO THE PROCEDURES DELINEATED IN THIS APPENDIX. ANY EXCEPTIONS TO THE BASIC PROCEDURES ARE SPECIFIED IN THIS APPENDIX.
- B. THE OUTLOADING PROCEDURES DEPICTED IN THIS DRAWING ARE APPLICABLE TO LOADS OF SCL #34A. SEE PAGES 4 AND 5 FOR DETAILS OF THE PALLET UNITS. AN M3A1 (HYUNDAI) CROP IS SHOWN AS TYPICAL. OTHER MANUFACTURER'S CROPS CAN BE USED FOR THE LOAD SHOWN ON PAGE 2. THE SEQUENTIAL LOADING PROCEDURES DEPICTED AT LEFT DESCRIBE THE SEQUENCE USED TO LOAD AN M3A1 CROP. FOR AN M3 (SUMMA) CROP, SEQUENTIAL LOADING PROCEDURES 2 THROUGH 9 MUST BE REVERSED. ACTUAL CROP CONFIGURATION WILL DETERMINE WHETHER THE SEQUENTIAL LOADING STARTS AT THE AFT OR THE FORWARD END OF THE CROP.
- C. THE LOADING PROCEDURES DEPICTED HEREIN MAY ALSO BE USED FOR OUTLOADING SIMILAR SCL LOADS WHEN IDENTIFIED BY DIFFERENT NATIONAL STOCK NUMBERS (NSN) THAN WHAT IS SHOWN ON PAGE 4, PROVIDED THE OVERALL PALLET UNIT DIMENSIONS DO NOT VARY FROM WHAT IS DELINEATED HEREIN.
- D. DIMENSIONS, CUBE AND WEIGHT OF THE PALLET UNITS WILL VARY SLIGHTLY DEPENDING UPON THE ACTUAL DIMENSIONS OF THE BOXES AND THE WEIGHT OF THE SPECIFIC ITEM BEING UNITIZED.
- E. ALTERNATE NSN/DODIC COMBINATIONS ARE SHOWN IN THE CHART ON PAGE 4. THESE ALTERNATES MAY BE SUBSTITUTED FOR SOME OR ALL THE DEPICTED NSN/DODICS IF NECESSARY DUE TO THE ITEMS OR QUANTITIES ON HAND.
- F. DIMENSIONS GIVEN FOR DUNNAGE ASSEMBLIES WILL BE FIELD CHECKED PRIOR TO THEIR ASSEMBLY. PALLET UNITS MUST FIT SNUGLY AGAINST THE DUNNAGE ASSEMBLIES. THIS GUIDANCE MUST BE APPLIED PRIOR TO BEGINNING AN OUTLOADING OPERATION. ALSO, DUE TO VARIATION OF PALLET UNIT DIMENSIONS, ADJUSTMENTS MAY BE REQUIRED AS TO THE LOCATION OF CERTAIN PIECES ON DUNNAGE ASSEMBLIES.
- G. ALL WEB STRAP TIEDOWN ASSEMBLIES MUST HAVE THE EXCESS LENGTH OF THE STRAP SECURED. ROLL UP AND BUNDLE THE EXCESS LENGTH OF WEB STRAP, SECURING WITH CABLE TIES. SEE THE "STRAP END SECUREMENT" DETAIL AND GENERAL NOTE "K.12" IN THE BASIC PROCEDURE DRAWING 19-48-4905-CA17Q6.
- H. UNUSED WEB STRAP TIEDOWN ASSEMBLIES MUST BE SECURED AS DELINEATED IN GENERAL NOTE "K.13" IN THE BASIC PROCEDURES DRAWING 19-48-4905-CA17Q6.
- J. CONVERSION TO METRIC EQUIVALENTS: DIMENSIONS WITHIN THIS DOCUMENT ARE EXPRESSED IN INCHES, AND WEIGHTS ARE EXPRESSED IN POUNDS. WHEN NECESSARY, THE METRIC EQUIVALENTS MAY BE COMPUTED ON THE BASIS OF ONE INCH EQUALS 25.4MM AND ONE POUND EQUALS 0.454 KG.

BILL OF MATERIAL

| LUMBER | LINEAR FEET | BOARD FEET |
|-------------------------------|------------------|----------------|
| 2" X 3" (ACTUAL) | 5 | 3 |
| 2" X 4" | 26 | 17 |
| 2" X 6" | 70 | 70 |
| 2" X 8" | 47 | 62 |
| NAILS | NO. REQD | POUNDS |
| 6d (2") | 12 | 1/4 |
| 10d (3") | 200 | 3-1/4 |
| 12d (3-1/4") | 4 | 1/4 |
| PLYWOOD, 1/4" - - - | 44.33 SQ FT REQD | - - 30-1/2 LBS |
| 2" WEB STRAP TIEDOWN ASSY - - | 1 REQD | - - - 6 LBS |

LOAD AS SHOWN

| ITEM | QUANTITY | WEIGHT (APPROX) |
|-------------------------------|--------------|---------------------|
| D514 PALLET UNIT - - - - - | 15 - - - - - | 13,230 LBS |
| DA12 PALLET UNIT - - - - - | 1 - - - - - | 1,297 LBS |
| DA13 PALLET UNIT - - - - - | 2 - - - - - | 3,670 LBS |
| COMBO N289/N523 PALLET UNIT - | 1 - - - - - | 431 LBS |
| DUNNAGE - - - - - | - - - - - | 342 LBS |
| CROP - - - - - | - - - - - | 3,800 LBS |
| TOTAL WEIGHT - - - - - | | 22,770 LBS (APPROX) |

SCL #34A COMPOSITION CHART

| DODIC | NSN | NOMENCLATURE | UNIT DWG | REQD | UNITS REQD | HC |
|-------|------------------|--|-----------|------|------------|-------|
| D514 | 1320-01-268-0385 | PROJ, 155MM RAAM-S M741A1 | 8837839 | 120 | 15 PALLETS | 1. 1D |
| DA12 | 1320-01-454-4063 | MODULAR ARTILLERY CHARGE SYSTEM (MACS), M231 | 4326/50 | 120 | 1 PALLET | 1. 3C |
| DA13 | 1320-01-457-4603 | MODULAR ARTILLERY CHARGE SYSTEM (MACS), M232 | 4326/50A | 300 | 2 PALLETS | 1. 3C |
| N289* | 1390-01-282-6038 | FUZE, ELECTRONIC TIME W/O BOOSTER M762 | 4116/156S | 128 | 8 BOXES | 1. 4S |
| N523 | 1390-01-481-2024 | PRIMER, PERCUSSION M82 | 4116/158G | 200 | 1 BOX | 1. 4S |

NOTE: THE DODICS LISTED BELOW MAY BE USED AS ALTERNATES FOR THE DODICS WITH MATCHING SYMBOLS SHOWN ABOVE IF THE QUANTITY OF THE DODICS SHOWN ABOVE IS INSUFFICIENT.

| | | | | | | |
|-------|------------------|-----------------------------------|----------|--|--|-------|
| N285* | 1390-01-247-4013 | FUZE, MTSQ M577A1 WITHOUT BOOSTER | 4116/156 | | | 1. 4S |
|-------|------------------|-----------------------------------|----------|--|--|-------|

D514 PALLET UNIT DETAIL

8 155MM CTG @ 104 LBS - - - - - 832 LBS (APPROX)
 DUNNAGE AND PALLET - - - - - 50 LBS

TOTAL WEIGHT - - - - - 882 LBS (APPROX)
 CUBE - - - - - 9.6 CU FT (APPROX)

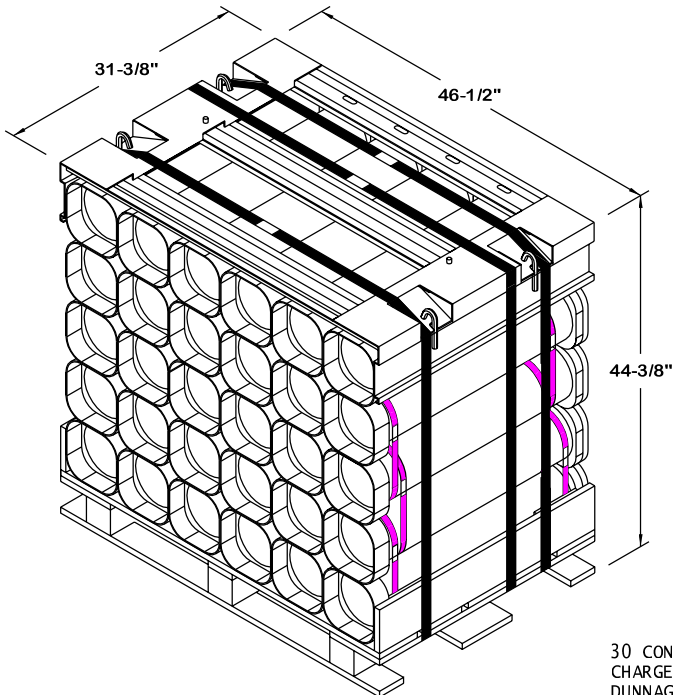
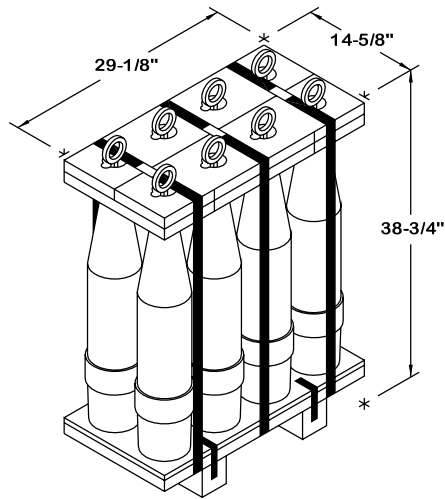

DA12 PALLET UNIT DETAIL

30 CONTAINERS OF MACS PROPELLING
 CHARGES (4 PER CONTAINER) @ 38 LBS - - - - - 1,140 LBS (APPROX)
 DUNNAGE - - - - - 97 LBS
 PALLET - - - - - 60 LBS

TOTAL WEIGHT - - - - - 1,297 LBS (APPROX)
 CUBE - - - - - 37.5 CU FT (APPROX)

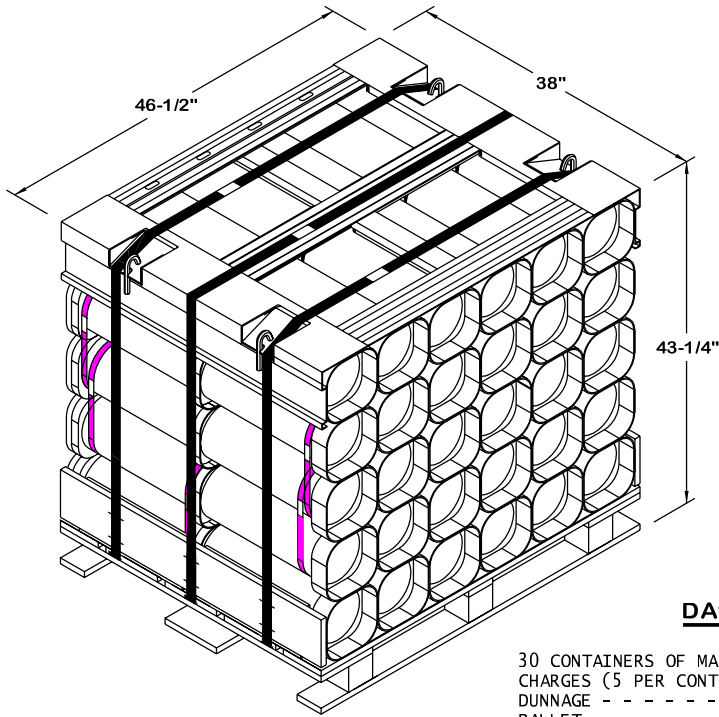

DA13 PALLET UNIT DETAIL

| | | |
|------------------------------------|-------|--------------------|
| 30 CONTAINERS OF MACS PROPELLING | | |
| CHARGES (5 PER CONTAINER) @ 55 LBS | ----- | 1,650 LBS (APPROX) |
| DUNNAGE | ----- | 110 LBS |
| PALLET | ----- | 75 LBS |

| | | |
|--------------|-------|---------------------|
| TOTAL WEIGHT | ----- | 1,835 LBS (APPROX) |
| CUBE | ----- | 44.3 CU FT (APPROX) |

LOAD STRAP, 3/4" X .035" OR .031" X 10'-7" LONG STEEL STRAPPING (3 REQD). PRE-POSITION ON THE PALLET DECK PRIOR TO PLACING THE BOXES ON THE PALLET. LOAD STRAPS MUST BE TENSIONED AND SEALED PRIOR TO APPLICATION OF TIEDOWN STRAPS.

TIEDOWN STRAP, 3/4" X .035" OR .031" X 9'-3" LONG STEEL STRAPPING (3 REQD). INSTALL TO PASS UNDER THE TOP DECK BOARDS OF THE PALLET AND TO BE LOCATED AS SHOWN. TIEDOWN STRAPS WILL NOT BE APPLIED UNTIL THE LOAD STRAPS HAVE BEEN TENSIONED AND SEALED.

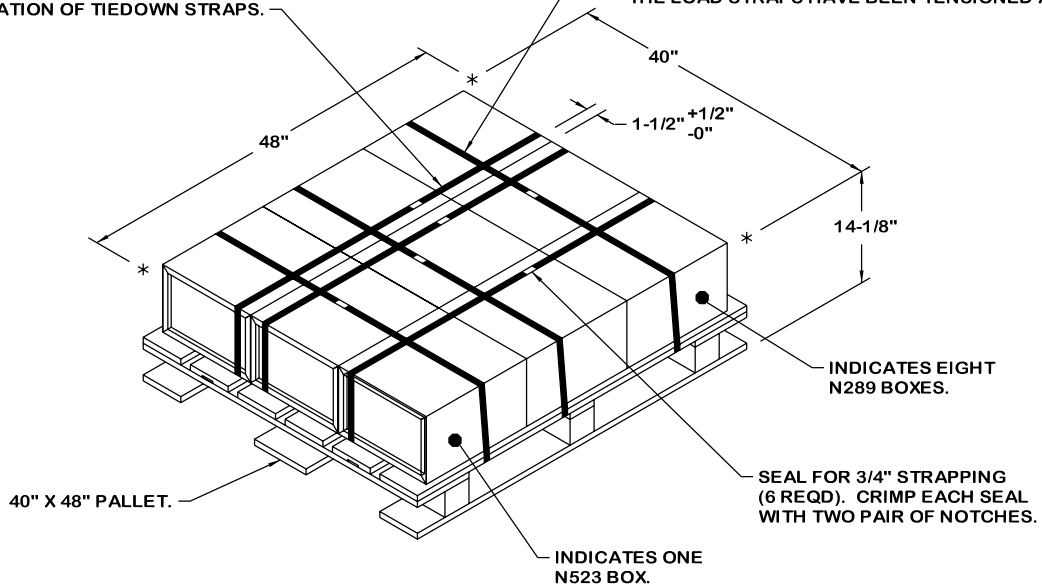

THE PALLET UNIT ABOVE SHOULD BE CONSTRUCTED IAW AMC DRAWING 19-48-4116-20PA1002 AS MUCH AS PRACTICABLE. CENTER AND SQUARE THE BOXES ON THE PALLET.

LIGHT N289/N523 COMBINATION PALLET UNIT DETAIL

| | | |
|---|-------|------------------|
| 8 BOXES OF FUZES (16 PER BOX) @ 40 LBS | ----- | 320 LBS (APPROX) |
| 1 LIGHT BOX OF PRIMERS (200 PER BOX) @ 25 LBS | ----- | 25 LBS (APPROX) |
| DUNNAGE | ----- | 6 LBS |
| PALLET | ----- | 80 LBS |

| | | |
|--------------|-------|---------------------|
| TOTAL WEIGHT | ----- | 431 LBS (APPROX) |
| CUBE | ----- | 15.7 CU FT (APPROX) |

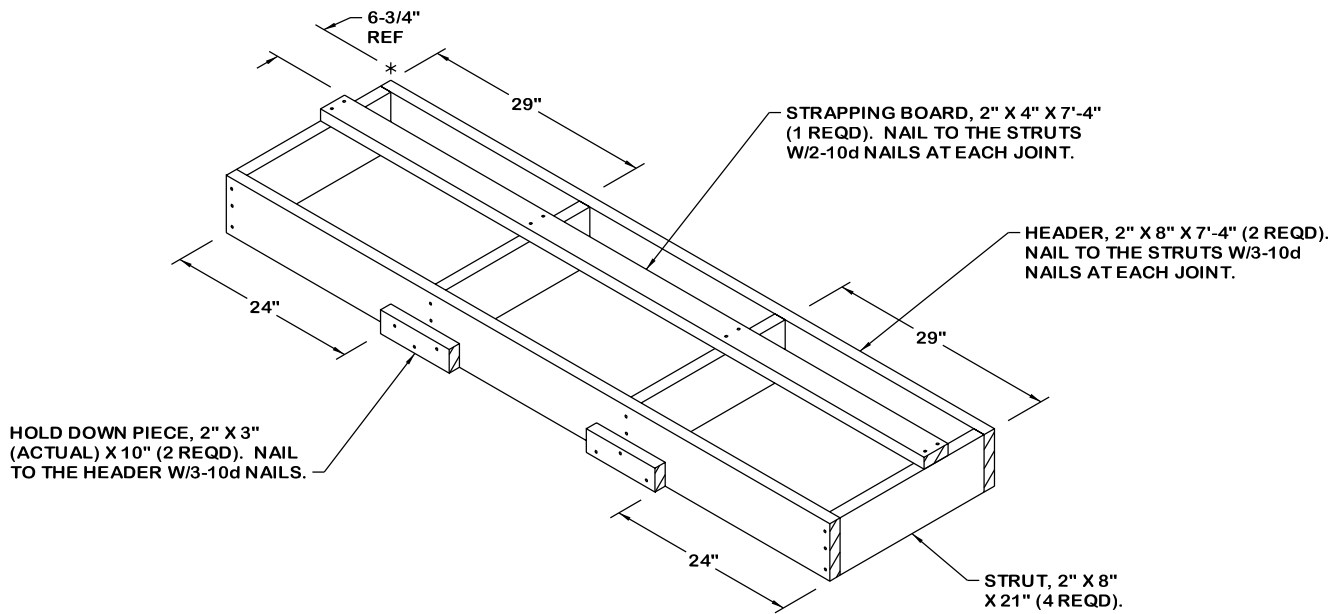

AFT FILLER ASSEMBLY

INSTALL WITH THE HOLD DOWN PIECES TOWARDS THE LADING. ENSURE THAT THE STRAPPING BOARD IS IN ALIGNMENT WITH THE NINETEENTH TIEDOWN ANCHOR.

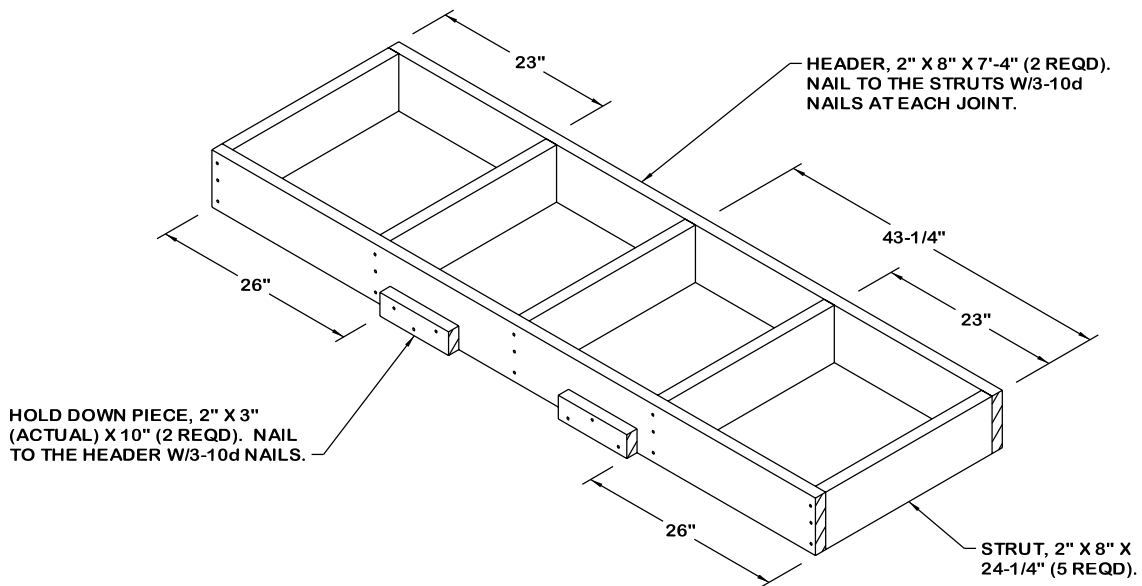

FORWARD FILLER ASSEMBLY

INSTALL WITH THE HOLD DOWN PIECES TOWARDS THE LADING. STRUT LENGTH MAY BE MODIFIED TO PROVIDE FOR A TIGHT END OF LOAD FIT.

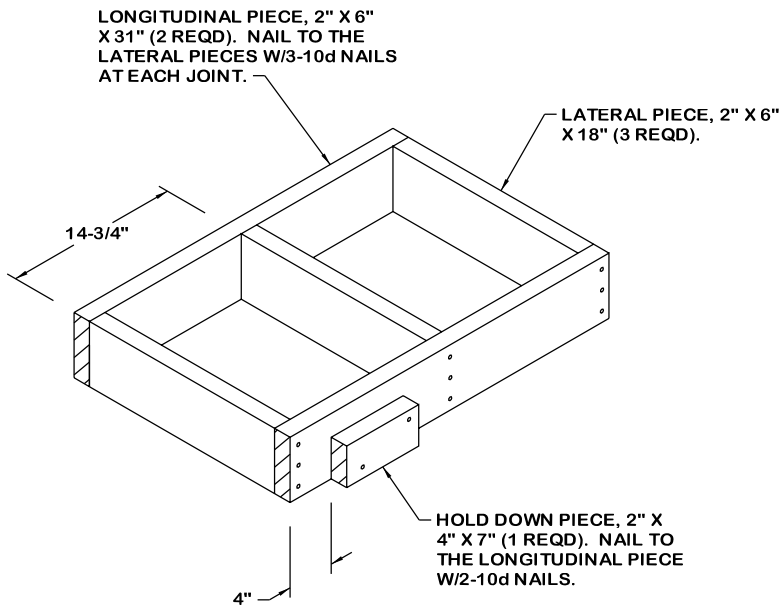

SIDE BLOCKING ASSEMBLY A

INSTALL WITH THE HOLD DOWN PIECE TOWARDS THE LADING.

BEARING PIECE, 2" X 6" X 46-1/2" (QUADRUPLED) (1 REQD). LAMINATE THE SECOND PIECE TO THE FIRST PIECE W/3-10d NAILS. LAMINATE EACH ADDITIONAL PIECE IN A LIKE MANNER.

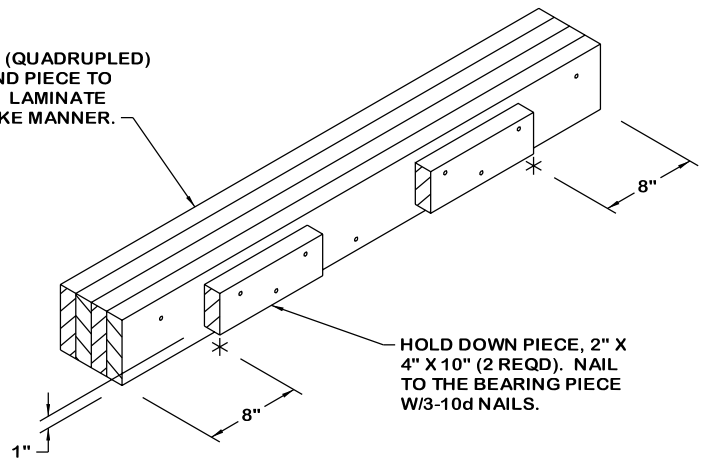

SIDE BLOCKING ASSEMBLY B

INSTALL WITH THE HOLD DOWN PIECES TOWARDS THE LADING.

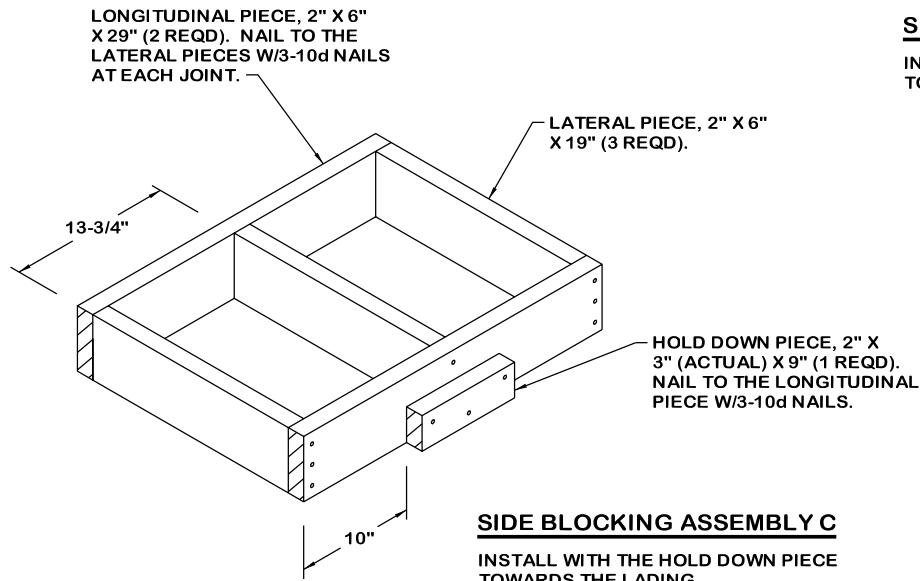

SIDE BLOCKING ASSEMBLY C

INSTALL WITH THE HOLD DOWN PIECE TOWARDS THE LADING.

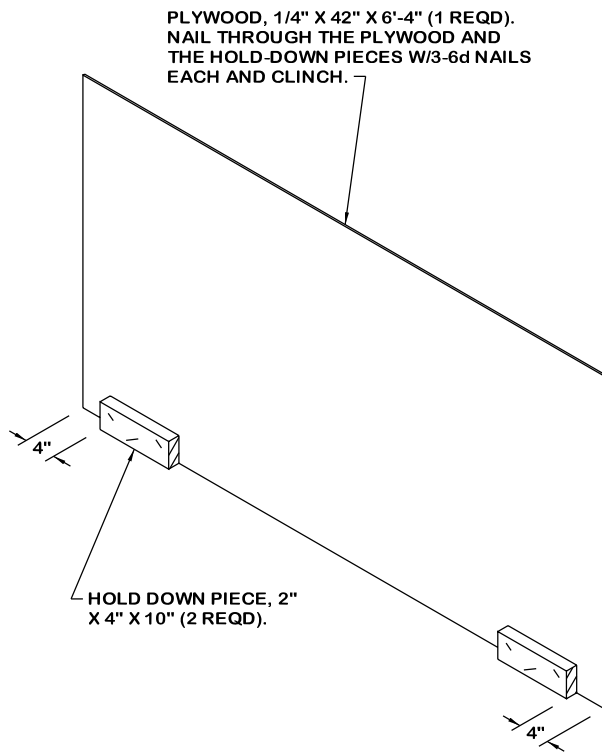

SEPARATOR GATE

INSTALL WITH THE HOLD DOWN PIECES
 TOWARDS THE DA13 PALLET UNITS.

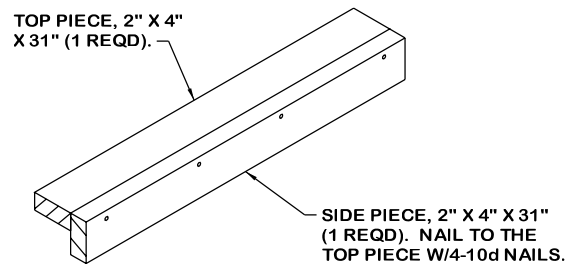

STRAPPING BOARD ASSEMBLY