

APPROVED BY  
BUREAU OF EXPLOSIVES

*[Signature]*

DATE 10/12/2000

# APPENDIX 34

## LOADING AND BRACING PROCEDURES FOR STRATEGIC CONFIGURED LOAD (SCL) ON CONTAINER ROLL IN/OUT PLATFORM (CROP)

### SCL #34 - 155MM RAAM-S M741A1

#### INDEX

ITEM	PAGE(S)
TYPICAL LOADING PROCEDURES - - - - -	2
GENERAL NOTES AND SEQUENTIAL LOADING PROCEDURES - - - - -	3-4
PALLET UNIT DETAILS - - - - -	4-6
DETAILS - - - - -	7-8

**NOTICE:** THIS APPENDIX CANNOT STAND ALONE BUT MUST BE USED IN CONJUNCTION WITH THE BASIC CROP OUTLOADING PROCEDURES DRAWING 19-48-4905-CA17Q6.

- LOADING AND BRACING SPECIFICATIONS SET FORTH WITHIN THIS DRAWING ARE APPLICABLE TO LOADS THAT ARE TO BE SHIPPED BY TRAILER/CONTAINER-ON-FLATCAR (T/COFC) RAIL CARRIER SERVICE. THESE SPECIFICATIONS MAY ALSO BE USED FOR LOADS THAT ARE TO BE MOVED BY MOTOR OR WATER CARRIERS.

### U.S. ARMY MATERIEL COMMAND DRAWING

APPROVED, U.S. ARMY OPERATIONS SUPPORT COMMAND  <i>[Signature: Timothy R. Fore]</i>	ENGINEER	BASIC	LAURA FIEFFER		DO NOT SCALE			
		REV.			WEBSITE: HTTP://WWW.DAC.ARMY.MIL			
	TECHNICIAN	BASIC			OCTOBER 2000			
	REV.							
	DRAFTSMAN	BASIC						
		REV.						
APPROVED BY ORDER OF COMMANDING GENERAL, U.S. ARMY MATERIEL COMMAND  <i>[Signature: J. P. White]</i>  U.S. ARMY DEFENSE AMMUNITION CENTER	TRANSPORTATION ENGINEERING DIVISION	<i>[Signature: William P. Smith]</i>			CLASS	DIVISION	DRAWING	FILE
	VALIDATION ENGINEERING DIVISION	<i>[Signature: Philip W. ...]</i>			19	48	4905/ 34	CA17Q6
	ENGINEERING DIRECTORATE	<i>[Signature: ...]</i>						

PROJECT CAP-TV 6/34-00

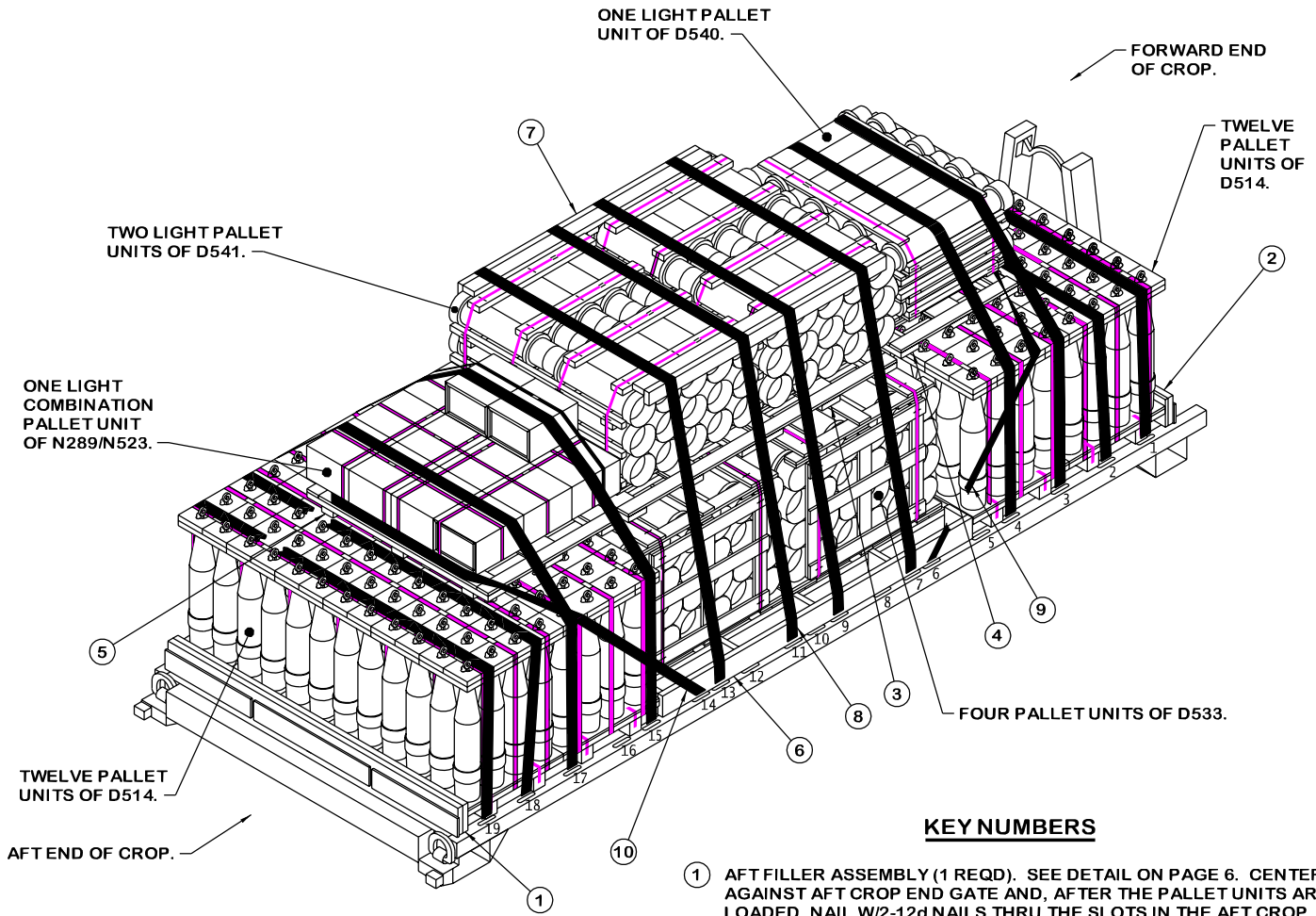

**ISOMETRIC VIEW**

**KEY NUMBERS**

(KEY NUMBERS CONTINUED)

- ⑦ STRAPPING BOARD ASSEMBLY (2 REQD). SEE THE DETAIL ON PAGE 8. INSTALL ON THE EDGES OF THE LIGHT D541 PALLET UNITS.
- ⑧ HOLD-DOWN STRAP, 3-INCH WIDE WEB STRAP TIEDOWN ASSEMBLY FOR CROP (12 REQD). INSTALL EACH HOLD-DOWN STRAP TO EXTEND FROM THE DESIGNATED TIEDOWN ANCHOR ON ONE SIDE OF CROP, OVER THE TOP OF THE PALLET UNITS, TO THE CORRESPONDING TIEDOWN ANCHOR ON THE OPPOSITE SIDE OF THE CROP. ALIGN SCUFF SLEEVES OVER ALL SHARP EDGES AND FIRMLY TENSION STRAP. SEE GENERAL NOTE "H" ON PAGE 3.
- ⑨ FORWARD END RESTRAINT STRAP, 3-INCH WIDE WEB STRAP TIEDOWN ASSEMBLY FOR CROP (1 REQD). INSTALL THE STRAP FROM THE SIXTH TIEDOWN ANCHOR ON ONE SIDE OF THE CROP, OVER THE D514 PALLET UNITS AND AROUND THE PALLET POSTS OF THE LIGHT D540 PALLET UNIT, BACK DOWN TO THE SIXTH TIEDOWN ANCHOR ON THE OPPOSITE SIDE OF THE CROP. ALIGN SCUFF SLEEVES OVER ALL SHARP EDGES AND FIRMLY TENSION STRAP. SEE GENERAL NOTE "H" ON PAGE 3.
- ⑩ AFT END RESTRAINT STRAP, 3-INCH WIDE WEB STRAP TIEDOWN ASSEMBLY FOR CROP (1 REQD). INSTALL THE STRAP FROM THE FOURTEENTH TIEDOWN ANCHOR ON ONE SIDE OF THE CROP, OVER THE D514 PALLET UNITS AND AROUND THE PALLET POSTS OF THE LIGHT COMBINATION N289/N523 PALLET UNIT, AND BACK DOWN TO THE FOURTEENTH TIEDOWN ANCHOR ON THE OPPOSITE SIDE OF THE CROP. DO NOT INSTALL OVER THE HOLD-DOWN STRAP ATTACHED TO THE SEVENTEENTH TIEDOWN ANCHOR, THREAD BEHIND THIS STRAP, FLUSH AGAINST THE D514 PALLET UNIT. ALIGN SCUFF SLEEVES OVER ALL SHARP EDGES AND FIRMLY TENSION STRAP. SEE GENERAL NOTE "H" ON PAGE 3.

- ① AFT FILLER ASSEMBLY (1 REQD). SEE DETAIL ON PAGE 6. CENTER AGAINST AFT CROP END GATE AND, AFTER THE PALLET UNITS ARE LOADED, NAIL W/2-12d NAILS THRU THE SLOTS IN THE AFT CROP END GATE INTO THE AFT FILLER ASSEMBLY, LEAVING THE NAIL HEADS PROTRUDING THRU THE SLOTS TO PROVIDE LATERAL RESTRAINT.
- ② FORWARD FILLER, 1" OR 2" X 8" X 7'-4" (AS REQD). LAMINATE EACH PIECE TO THE PREVIOUS PIECE W/8 NAILS OF A SUITABLE SIZE (6d NAILS FOR 1" THICK MATERIAL). CENTER AGAINST FORWARD CROP END GATE AND, AFTER THE PALLET UNITS ARE LOADED, NAIL W/2-12d NAILS THRU THE HOLES IN THE FORWARD CROP END GATE INTO THE FORWARD FILLER PIECES, LEAVING THE NAIL HEADS PROTRUDING THRU THE HOLES TO PROVIDE LATERAL AND VERTICAL RESTRAINT.
- ③ PALLET SUPPORT ASSEMBLY A (1 REQD). SEE DETAIL ON PAGE 7. POSITION THE ASSEMBLY ON TOP OF THE D533 PALLET UNITS SO THAT ASSEMBLY LATERAL PIECES ARE LENGTHWISE ON THE LOAD AND REST ON THE TOP DUNNAGE ASSEMBLIES OF THE D533 PALLET UNITS. CENTER THE ASSEMBLY LATERALLY AND LONGITUDINALLY ON THE D533 PALLET UNITS.
- ④ PALLET SUPPORT ASSEMBLY B (1 REQD). SEE DETAIL ON PAGE 7. POSITION THE ASSEMBLY ON TOP OF THE FORWARD D514 PALLET UNITS SO THAT ASSEMBLY LATERAL PIECES ARE LENGTHWISE ON THE LOAD AND FIT BETWEEN THE LIFTING RINGS OF THE D514 PROJECTILES. CENTER THE ASSEMBLY LATERALLY ON THE D514 PALLET UNITS AND POSITION SO THAT THE LIGHT D540 PALLET UNIT WILL BE TIGHT AGAINST THE ADJACENT LIGHT D541 PALLET UNIT.
- ⑤ PALLET SUPPORT ASSEMBLY C (1 REQD). SEE DETAIL ON PAGE 8. POSITION THE ASSEMBLY ON TOP OF THE AFT D514 PALLET UNITS SO THAT ASSEMBLY LATERAL PIECES ARE LENGTHWISE ON THE LOAD AND FIT BETWEEN THE LIFTING RINGS OF THE D514 PROJECTILES. CENTER THE ASSEMBLY LATERALLY ON THE D514 PALLET UNITS AND POSITION SO THAT THE LIGHT N289/N523 COMBINATION PALLET UNIT WILL BE TIGHT AGAINST THE ADJACENT LIGHT D541 PALLET UNIT.
- ⑥ SIDE BLOCKING ASSEMBLY (2 REQD). SEE THE DETAIL ON PAGE 8. INSTALL ONE ON EACH SIDE OF THE CROP ADJACENT TO THE D533 PALLET UNITS. AFTER THE HOLD-DOWN STRAPS ARE INSTALLED, NAIL THROUGH THE STRAP ATTACHMENT SLOTS OF TWO HOLD-DOWN STRAPS (ONE AT EACH END OF THE ASSEMBLY) INTO SIDE BLOCKING W/1-10d PARTIALLY DRIVEN NAIL AND BEND OVER SIDE OF HOOK.

**RECOMMENDED SEQUENTIAL PROCEDURES**

1. PREFABRICATE THE AFT FILLER ASSEMBLY, ONE PALLET SUPPORT ASSEMBLY "A", ONE PALLET SUPPORT ASSEMBLY "B", ONE PALLET SUPPORT ASSEMBLY "C", TWO SIDE BLOCKING ASSEMBLIES, AND TWO STRAPPING BOARD ASSEMBLIES. STRAP THE N523 BOX AND THE EXTRA N289 BOX TO THE TOP OF THE LIGHT N289 PALLET UNIT.
2. INSTALL THE AFT FILLER ASSEMBLY.
3. LOAD TWO ROWS OF SIX PALLET UNITS OF D514 AGAINST THE AFT END FILLER ASSEMBLY, CENTERING THE ROWS Laterally ON THE CROP.
4. LOAD TWO ROWS OF TWO PALLET UNITS EACH OF D533 AGAINST THE D514 PALLET UNITS, CENTERING THE ROWS Laterally ON THE CROP.
5. LOAD TWO ROWS OF SIX PALLET UNITS OF D514 AGAINST THE D533 PALLET UNITS, CENTERING THE ROWS Laterally ON THE CROP.
6. INSTALL THE FORWARD FILLER PIECES.
7. INSTALL THE PALLET SUPPORT ASSEMBLY "A" ON TOP OF THE FOUR D533 PALLET UNITS SO THAT THE LATERAL PIECES OF THE ASSEMBLY ARE LENGTHWISE ON THE LOAD, THE ASSEMBLY RESTS ON THE D533 PALLET UNIT TOP DUNNAGE ASSEMBLIES, AND THE ASSEMBLY IS CENTERED AS MUCH AS POSSIBLE Laterally AND Longitudinally ON THE D533 PALLET UNITS.
8. LOAD TWO LIGHT D541 PALLET UNITS ON TOP OF THE PALLET SUPPORT ASSEMBLY "A", ALIGNING THE PALLET SKIDS WITH THE PALLET SUPPORT ASSEMBLY LONGITUDINAL PIECES.
9. INSTALL ONE PALLET SUPPORT ASSEMBLY "B" ON TOP OF THE FORWARD D514 PALLET UNITS SO THAT THE LATERAL PIECES OF THE ASSEMBLY FIT BETWEEN THE LIFTING EYES ON THE D514 PALLET UNITS AND ARE LENGTHWISE ON THE LOAD. CENTER THE ASSEMBLY AS MUCH AS POSSIBLE Laterally ON THE D514 PALLET UNITS AND POSITION SO THAT THE LIGHT D540 PALLET UNIT WILL BE TIGHT AGAINST THE ADJACENT LIGHT D541 PALLET UNIT.
10. LOAD ONE LIGHT D540 PALLET UNIT ON TOP OF THE PALLET SUPPORT ASSEMBLY "B", AGAINST THE FORWARD LIGHT D541 PALLET UNIT, ALIGNING THE PALLET SKIDS WITH THE PALLET SUPPORT ASSEMBLY LONGITUDINAL PIECES.
11. INSTALL ONE PALLET SUPPORT ASSEMBLY "C" ON TOP OF THE AFT D514 PALLET UNITS SO THAT THE LATERAL PIECES OF THE ASSEMBLY FIT BETWEEN THE LIFTING EYES ON THE D514 PALLET UNITS AND ARE LENGTHWISE ON THE LOAD. CENTER THE ASSEMBLY AS MUCH AS POSSIBLE Laterally ON THE D514 PALLET UNITS AND POSITION SO THAT THE LIGHT N289/N523 COMBINATION PALLET UNIT WILL BE TIGHT AGAINST THE ADJACENT LIGHT D541 PALLET UNIT.
12. LOAD ONE LIGHT N289/N523 COMBINATION PALLET UNIT ON TOP OF THE PALLET SUPPORT ASSEMBLY "C", AGAINST THE AFT LIGHT D541 PALLET UNIT, ALIGNING THE PALLET SKIDS WITH THE PALLET SUPPORT ASSEMBLY LONGITUDINAL PIECES. SEE GENERAL NOTE "F" AT RIGHT.
13. INSTALL THE TWO SIDE BLOCKING ASSEMBLIES, ONE ON EITHER SIDE OF THE D533 PALLET UNITS.
14. INSTALL THE TWO STRAPPING BOARD ASSEMBLIES ON THE LIGHT D541 PALLET UNITS.

(CONTINUED ON PAGE 4)

BILL OF MATERIAL		
LUMBER	LINEAR FEET	BOARD FEET
1" X 4"	27	9
1" X 8"	8	5
2" X 3" (ACTUAL)	2	1
2" X 4"	53	36
2" X 6"	65	65
2" X 8"	29	39
NAILS	NO. REQD	POUNDS
6d (2")	56	1/2
10d (3")	129	2
12d (3-1/4")	4	NIL

**GENERAL NOTES**

- A. THIS APPENDIX CANNOT STAND ALONE BUT MUST BE USED IN CONJUNCTION WITH THE BASIC LOADING PROCEDURES DRAWING 19-48-4905-CA17Q6. TO PRODUCE AN APPROVED LOAD, ALL PERTINENT PROCEDURES, SPECIFICATIONS AND CRITERIA SET FORTH WITHIN THE BASIC DRAWING WILL APPLY TO THE PROCEDURES DELINEATED IN THIS APPENDIX. ANY EXCEPTIONS TO THE BASIC PROCEDURES ARE SPECIFIED IN THIS APPENDIX.
- B. THE OUTLOADING PROCEDURES DEPICTED IN THIS DRAWING ARE APPLICABLE TO LOADS OF SCL #34. SEE PAGES 4 THRU 6 FOR DETAILS OF THE PALLET UNITS. AN M3A1 (HYUNDAI) CROP IS SHOWN AS TYPICAL. OTHER MANUFACTURER'S CROPS CAN BE USED FOR THE LOAD SHOWN ON PAGE 2. THE SEQUENTIAL LOADING PROCEDURES DEPICTED AT LEFT DESCRIBE THE SEQUENCE USED TO LOAD AN M3A1 CROP. FOR AN M3 (SUMMA) CROP, SEQUENTIAL LOADING PROCEDURES 2 THROUGH 6 MUST BE REVERSED. ACTUAL CROP CONFIGURATION WILL DETERMINE WHETHER THE SEQUENTIAL LOADING STARTS AT THE AFT OR THE FORWARD END OF THE CROP.
- C. THE LOADING PROCEDURES DEPICTED HEREIN MAY ALSO BE USED FOR OUTLOADING SIMILAR SCL LOADS WHEN IDENTIFIED BY DIFFERENT NATIONAL STOCK NUMBERS (NSN) THAN WHAT IS SHOWN ON PAGE 4, PROVIDED THE OVERALL PALLET UNIT DIMENSIONS DO NOT VARY FROM WHAT IS DELINEATED HEREIN.
- D. LIGHT PALLET UNITS MUST BE CONSTRUCTED IN ACCORDANCE WITH THE GUIDELINES DELINEATED IN THE BASIC UNITIZATION PROCEDURES DRAWING APPLICABLE TO THAT PALLET UNIT.
- E. DIMENSIONS, CUBE AND WEIGHT OF THE PALLET UNITS WILL VARY SLIGHTLY DEPENDING UPON THE ACTUAL DIMENSIONS OF THE BOXES AND THE WEIGHT OF THE SPECIFIC ITEM BEING UNITIZED.
- F. ALTERNATE NSN/DODIC COMBINATIONS ARE SHOWN IN THE CHART ON PAGE 4. THESE ALTERNATES MAY BE SUBSTITUTED FOR SOME OR ALL THE DEPICTED NSN/DODICS IF NECESSARY DUE TO THE ITEMS OR QUANTITIES ON HAND.
- G. DIMENSIONS GIVEN FOR DUNNAGE ASSEMBLIES WILL BE FIELD CHECKED PRIOR TO THEIR ASSEMBLY. PALLET UNITS MUST FIT SNUGLY AGAINST THE DUNNAGE ASSEMBLIES. THIS GUIDANCE MUST BE APPLIED PRIOR TO BEGINNING AN OUTLOADING OPERATION. ALSO, DUE TO VARIATION OF PALLET UNIT DIMENSIONS, ADJUSTMENTS MAY BE REQUIRED AS TO THE LOCATION OF CERTAIN PIECES ON DUNNAGE ASSEMBLIES.
- H. ALL WEB STRAP TIEDOWN ASSEMBLIES MUST HAVE THE EXCESS LENGTH OF THE STRAP SECURED. ROLL UP AND BUNDLE THE EXCESS LENGTH OF WEB STRAP, SECURING WITH CABLE TIES. SEE THE "STRAP END SECUREMENT" DETAIL AND GENERAL NOTE "K.12" IN THE BASIC PROCEDURE DRAWING 19-48-4905-CA17Q6.
- J. CONVERSION TO METRIC EQUIVALENTS: DIMENSIONS WITHIN THIS DOCUMENT ARE EXPRESSED IN INCHES, AND WEIGHTS ARE EXPRESSED IN POUNDS. WHEN NECESSARY, THE METRIC EQUIVALENTS MAY BE COMPUTED ON THE BASIS OF ONE INCH EQUALS 25.4MM AND ONE POUND EQUALS 0.454 KG.

**LOAD AS SHOWN**

ITEM	QUANTITY	WEIGHT (APPROX)
D514 PALLET UNIT	24	21,168 LBS
D532 PALLET UNIT	4	4,640 LBS
LIGHT D540 PALLET UNIT	1	786 LBS
LIGHT D541 PALLET UNIT	2	2,146 LBS
COMBO N289/N523 PALLET UNIT	1	594 LBS
DUNNAGE		308 LBS
CROP		3,800 LBS

TOTAL WEIGHT - - - - - 33,442 LBS (APPROX)

## SCL #34 COMPOSITION CHART

DODIC	NSN	NOMENCLATURE	UNIT DWG	REQD	UNITS REQD	HC
D514	1320-01-268-0385	PROJ, 155MM RAAM-S M741A1	8837839	192	24 PALLETS	1. 1D
D533	1320-01-093-6856	CHG, PROPELLING 155MM RB M119A2 W/O PRIMER	4042A/9	96	4 PALLETS	1. 3C
D540	1320-00-935-1922	CHG, PROPELLING 155MM GB M3	4042A/3	48	1 LIGHT PLT	1. 3C
D541	1320-00-935-1923	CHG, PROPELLING 155MM WB M4A2	4042A/2	60	2 LIGHT PLTS	1. 3C
N289 *	1390-01-282-6038	FUZE, ELECTRONIC TIME W/O BOOSTER M762	4116/156S	208	13 BOXES	1. 4S
N523	1390-00-892-4202	PRIMER, PERCUSSION M82	4116/158E	200	1 BOX	1. 4S

**NOTE: THE DODICS LISTED BELOW MAY BE USED AS ALTERNATES FOR THE DODICS WITH MATCHING SYMBOLS SHOWN ABOVE IF THE QUANTITY OF THE DODICS SHOWN ABOVE IS INSUFFICIENT.**

N285 *	1390-01-247-4013	FUZE, MTSQ M577A1 WITHOUT BOOSTER	4116/156			1. 4S
--------	------------------	-----------------------------------	----------	--	--	-------

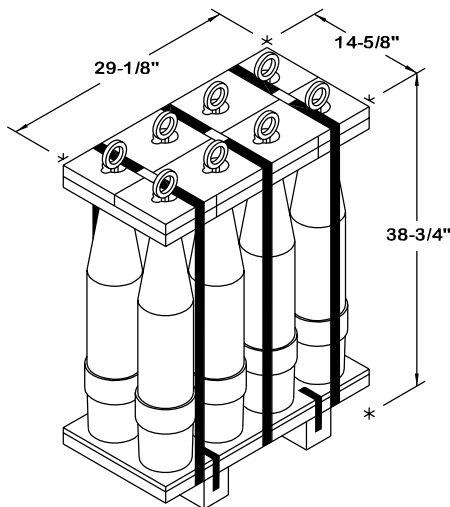

### D514 PALLET UNIT DETAIL

8 155MM CTG AT 104 LBS	-----	832 LBS (APPROX)
DUNNAGE AND PALLET	-----	50 LBS
<hr/>		
TOTAL WEIGHT	-----	882 LBS (APPROX)
CUBE	-----	9.6 CU FT (APPROX)

### SEQUENTIAL PROCEDURES CONTINUED FROM PAGE 3

15. INSTALL 12 WEB STRAP TIEDOWN ASSEMBLIES TO EXTEND FROM A TIEDOWN ANCHOR ON ONE SIDE OF THE CROP, OVER THE TOP OF PALLET UNITS, TO THE CORRESPONDING TIEDOWN ANCHOR ON THE OPPOSITE SIDE OF THE CROP.
16. INSTALL ONE WEB STRAP TIEDOWN ASSEMBLY FROM THE SIXTH TIEDOWN ANCHOR ON ONE SIDE OF THE CROP, AT AN ANGLE OVER THE D514 PALLET UNITS AND AROUND THE PALLET POSTS OF THE LIGHT D540 PALLET UNIT, AND BACK DOWN TO THE SIXTH TIEDOWN ANCHOR ON THE OPPOSITE SIDE OF THE CROP. DO NOT INSTALL OVER THE HOLD-DOWN STRAP ATTACHED TO THE FOURTH TIEDOWN ANCHOR, THREAD BEHIND THIS STRAP, FLUSH AGAINST THE D514 PALLET UNIT.
17. INSTALL ONE WEB STRAP TIEDOWN ASSEMBLY FROM THE FOURTEENTH TIEDOWN ANCHOR ON ONE SIDE OF THE CROP, AT AN ANGLE OVER THE D514 PALLET UNITS, AROUND THE PALLET POSTS OF THE LIGHT COMBINATION N289/N523 PALLET UNIT, AND BACK DOWN TO THE FOURTEENTH TIEDOWN ANCHOR ON THE OPPOSITE SIDE OF THE CROP. DO NOT INSTALL OVER THE HOLD-DOWN STRAP ATTACHED TO THE SEVENTEENTH TIEDOWN ANCHOR, THREAD BEHIND THIS STRAP, FLUSH AGAINST THE D514 PALLET UNIT.
18. NAIL THROUGH THE STRAP ATTACHMENT SLOT OF A HOLD-DOWN STRAP INTO EACH END OF THE SIDE BLOCKING ASSEMBLIES W/1-10d PARTIALLY DRIVEN NAIL AND BEND OVER SIDE OF HOOK.
19. NAIL TWO 12d RETAINING NAILS THRU THE SLOTS IN THE AFT CROP END GATE INTO THE AFT FILLER ASSEMBLY, LEAVING THE NAIL HEADS PROTRUDING THRU THE SLOTS TO PROVIDE LATERAL RESTRAINT.
20. NAIL THE TWO REMAINING 12d RETAINING NAILS THRU THE HOLES IN THE FORWARD CROP END GATE INTO THE FORWARD FILLER PIECES, LEAVING THE NAIL HEADS PROTRUDING THRU THE HOLES TO PROVIDE LATERAL AND VERTICAL RESTRAINT.

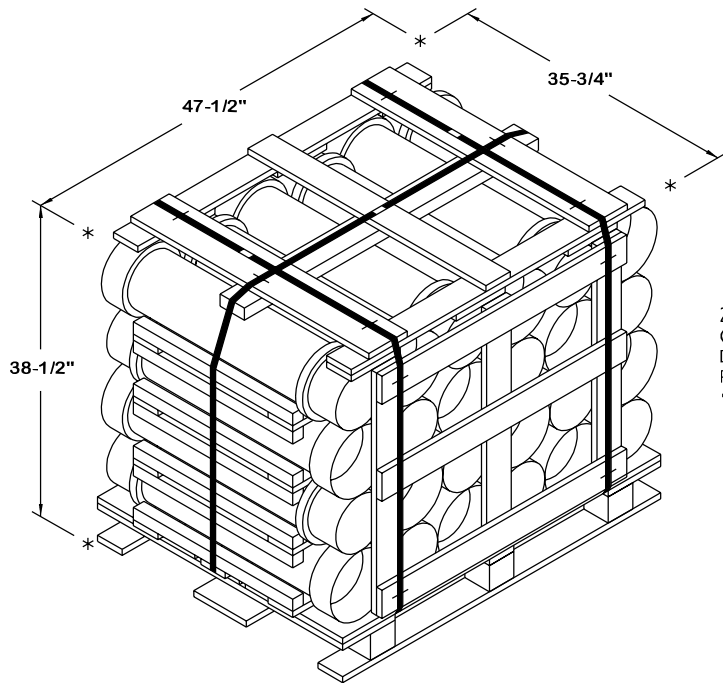

**D533 PALLET UNIT DETAIL**

24 CONTAINERS OF PROPELLING	
CHARGES (1 PER PA37 CONTAINER) AT 42 LBS	- 1,008 LBS (APPROX)
DUNNAGE	----- 87 LBS
PALLET	----- 65 LBS

TOTAL WEIGHT	----- 1,160 LBS (APPROX)
CUBE	----- 37.8 CU FT (APPROX)

THE LIGHT D540 PALLET UNIT DEPICTED AT RIGHT SHOULD BE CONSTRUCTED IAW THE AMC DRAWING LISTED IN THE CHART ON PAGE 4 WITH THE FOLLOWING CHANGES:

1. ELIMINATE TWO LAYERS OF CONTAINERS (16 CONTAINERS).
2. ELIMINATE ONE INTERMEDIATE DUNNAGE ASSEMBLY A AND ONE INTERMEDIATE DUNNAGE ASSEMBLY B.
3. REDUCE THE LOAD STRAP LENGTH TO 12'-6".

**LIGHT D540 PALLET UNIT DETAIL**

24 CONTAINERS OF PROPELLING	
CHARGES (2 PER M14 CONTAINER) AT 28 LBS	-- 672 LBS (APPROX)
DUNNAGE	----- 49 LBS
PALLET	----- 65 LBS

TOTAL WEIGHT	----- 786 LBS (APPROX)
CUBE	----- 26.0 CU FT (APPROX)

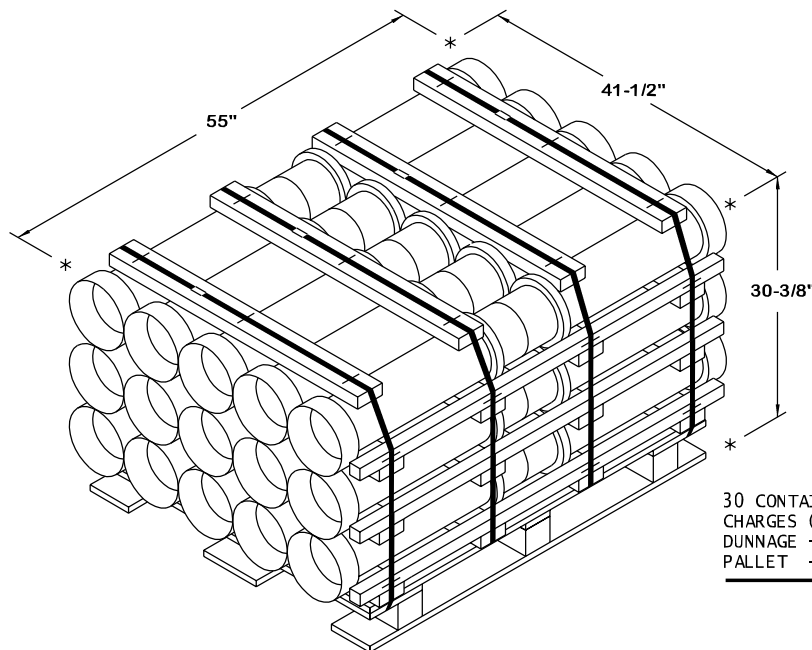
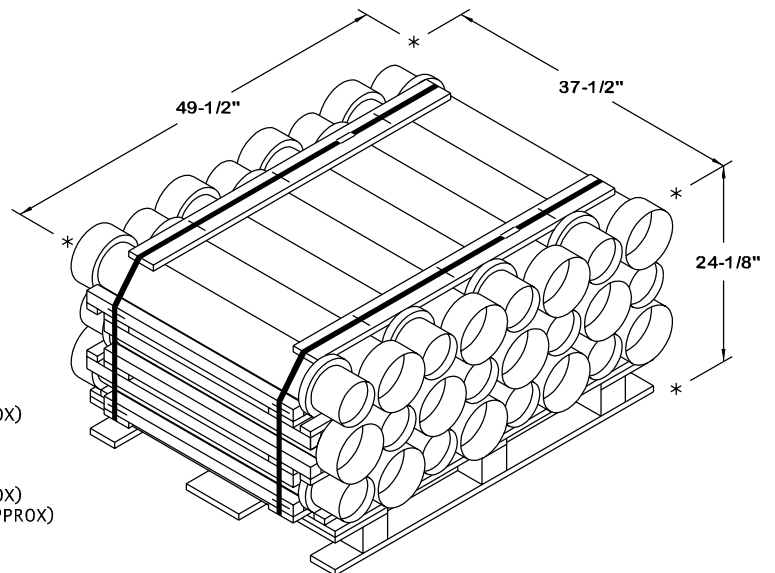

THE LIGHT D541 PALLET UNIT DEPICTED AT LEFT SHOULD BE CONSTRUCTED IAW THE AMC DRAWING LISTED IN THE CHART ON PAGE 4 WITH THE FOLLOWING CHANGES:

1. ELIMINATE TWO LAYERS OF CONTAINERS (20 CONTAINERS).
2. ELIMINATE TWO DUNNAGE ASSEMBLIES.
3. REDUCE THE TIEDOWN STRAP LENGTH TO 12'-2".

**LIGHT D541 PALLET UNIT DETAIL**

30 CONTAINERS OF PROPELLING	
CHARGES (1 PER M13 CONTAINER) AT 30 LBS	-- 900 LBS (APPROX)
DUNNAGE	----- 93 LBS
PALLET	----- 80 LBS

TOTAL WEIGHT	----- 1,073 LBS (APPROX)
CUBE	----- 40.2 CU FT (APPROX)

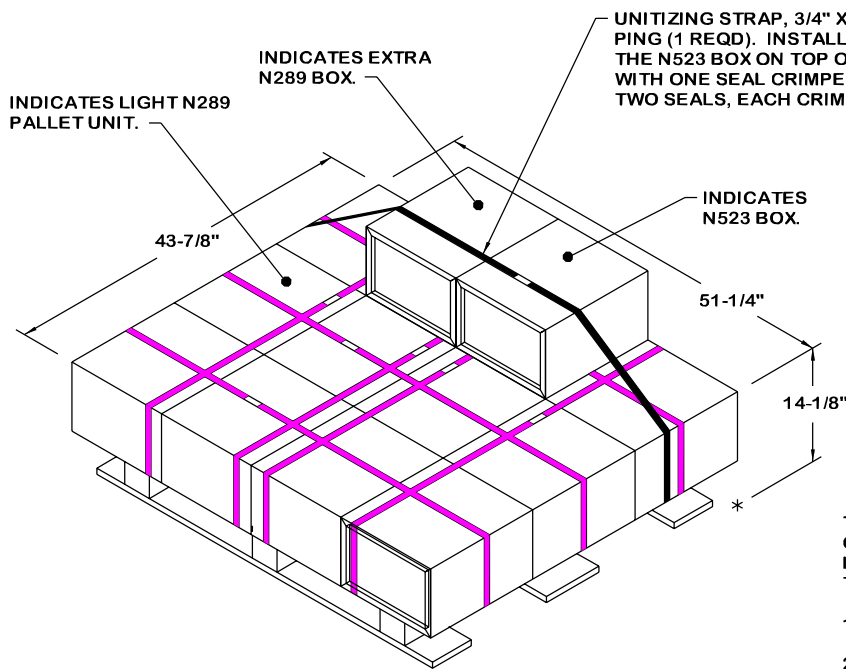

**SPECIAL NOTE:**

ALIGN THE TWO EXTRA BOXES WITH THE OUTER CENTER BOXES ON THE PALLET UNIT. INSTALL THE UNITIZATION STRAP OVER THE TWO BOXES, TOWARDS THE CENTER OF THE PALLET UNIT, AS SHOWN ABOVE.

THE LIGHT N289 PALLET UNIT SHOULD BE CONSTRUCTED IAW THE AMC DRAWING LISTED IN THE CHART ON PAGE 4 WITH THE FOLLOWING CHANGES:

1. ELIMINATE TWO LAYERS OF BOXES (24 BOXES).
2. REDUCE THE TIEDOWN STRAP LENGTH TO 9'-10".
3. REDUCE THE LOAD STRAP LENGTH TO 11'-1".

**LIGHT N289/N523 COMBINATION PALLET UNIT DETAIL**

13 BOXES OF FUZES (16 PER BOX) AT 40 LBS - - - - -	480 LBS (APPROX)
1 LIGHT BOX OF PRIMERS (200 PER BOX) AT 25 LBS - -	25 LBS (APPROX)
DUNNAGE - - - - -	9 LBS
PALLET - - - - -	80 LBS

TOTAL WEIGHT - - - - -	594 LBS (APPROX)
CUBE - - - - -	29.7 CU FT (APPROX)

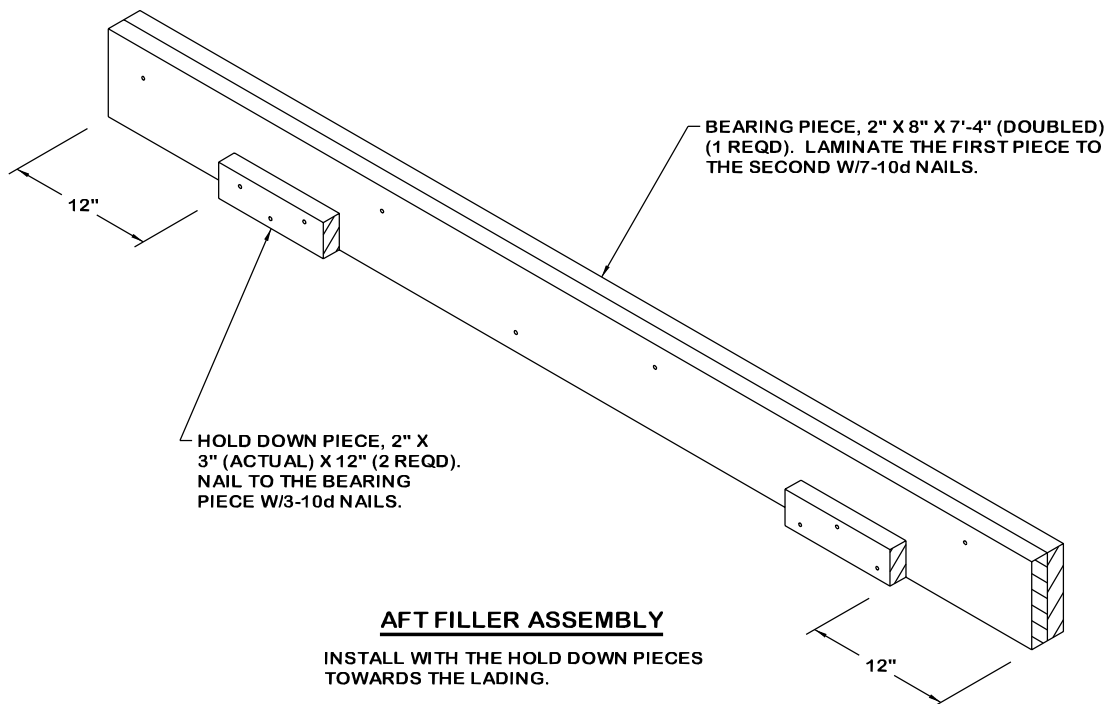

**AFT FILLER ASSEMBLY**

INSTALL WITH THE HOLD DOWN PIECES TOWARDS THE LADING.

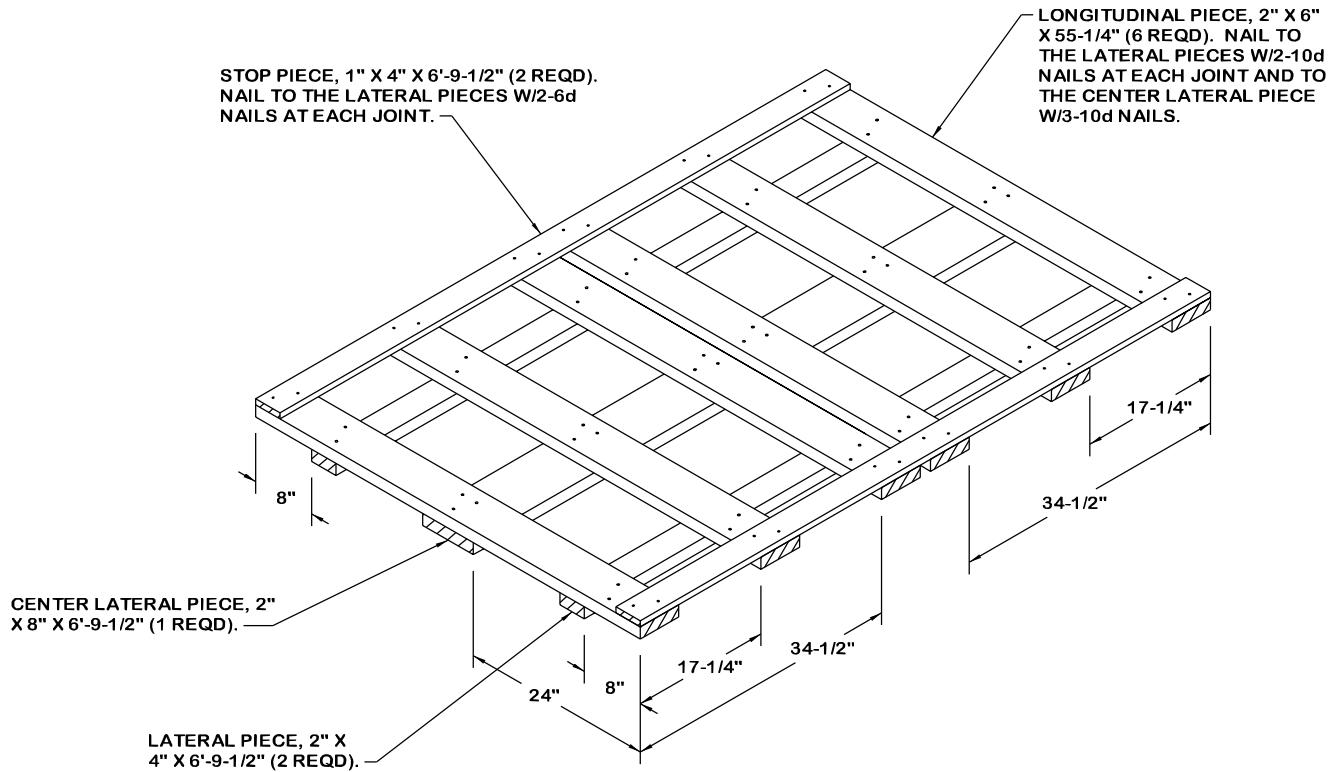

**PALLET SUPPORT ASSEMBLY A**

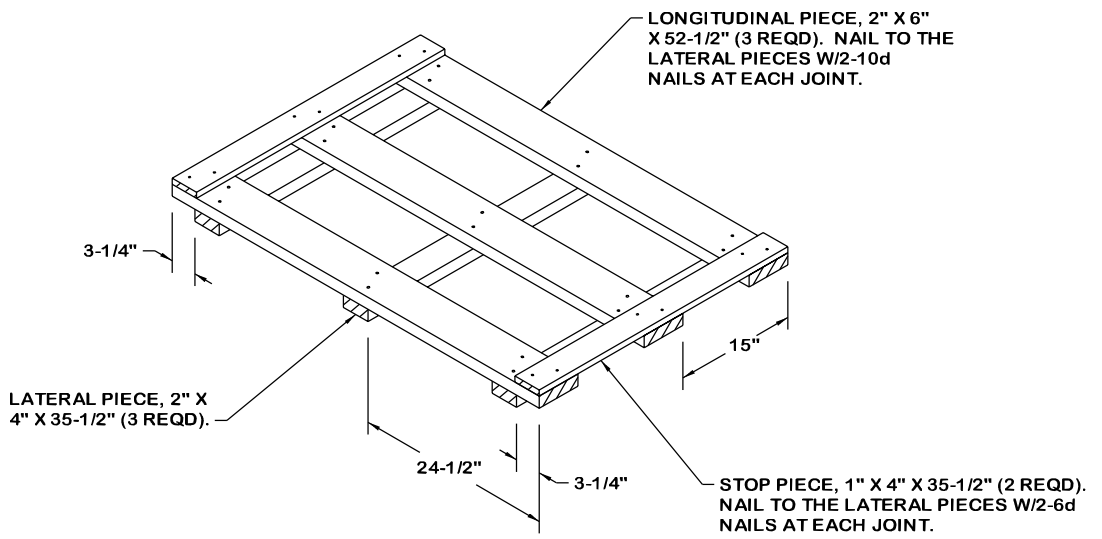

**PALLET SUPPORT ASSEMBLY B**

NOTE: THE LONGITUDINAL PIECES MUST NOT CONTACT THE TOP OF THE LIFTING RINGS OF THE D514 PALLET UNITS. IF THE SINGLE 2" X 4" LATERAL PIECES DO NOT PROVIDE SUFFICIENT CLEARANCE FOR THE D514 LIFTING RINGS, ADDITIONAL PIECES MAY BE ADDED. LAMINATE AN ADDITIONAL 1" OR 2" PIECE TO EACH LATERAL PIECE AS NEEDED TO CLEAR THE LIFTING RINGS.

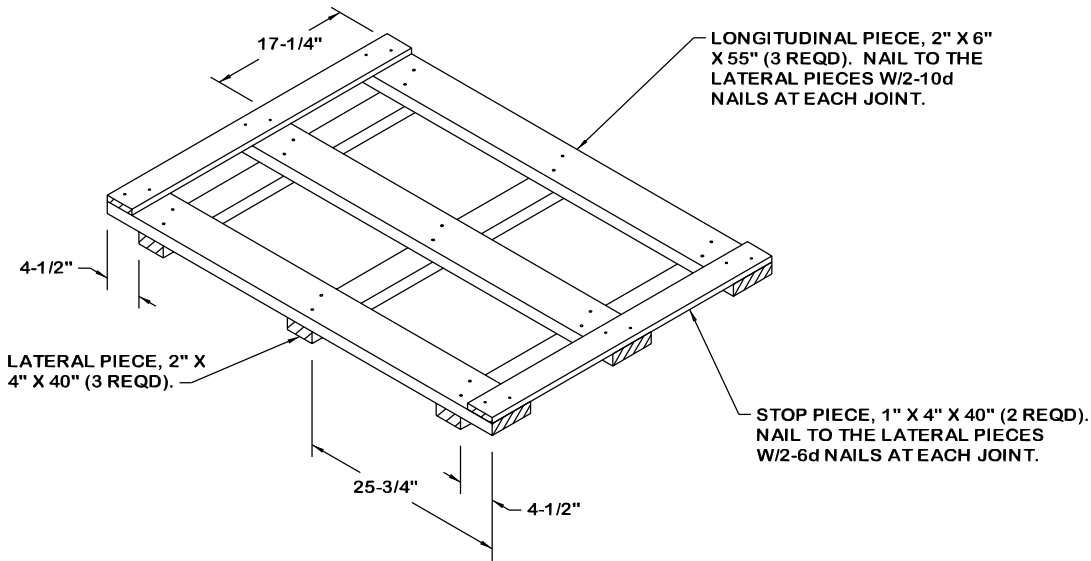

**PALLET SUPPORT ASSEMBLY C**

**NOTE:** THE LONGITUDINAL PIECES MUST NOT CONTACT THE TOP OF THE LIFTING RINGS OF THE D514 PALLET UNITS. IF THE SINGLE 2" X 4" LATERAL PIECES DO NOT PROVIDE SUFFICIENT CLEARANCE FOR THE D514 LIFTING RINGS, ADDITIONAL PIECES MAY BE ADDED. LAMINATE AN ADDITIONAL 1" OR 2" PIECE TO EACH LATERAL PIECE AS NEEDED TO CLEAR THE LIFTING RINGS.

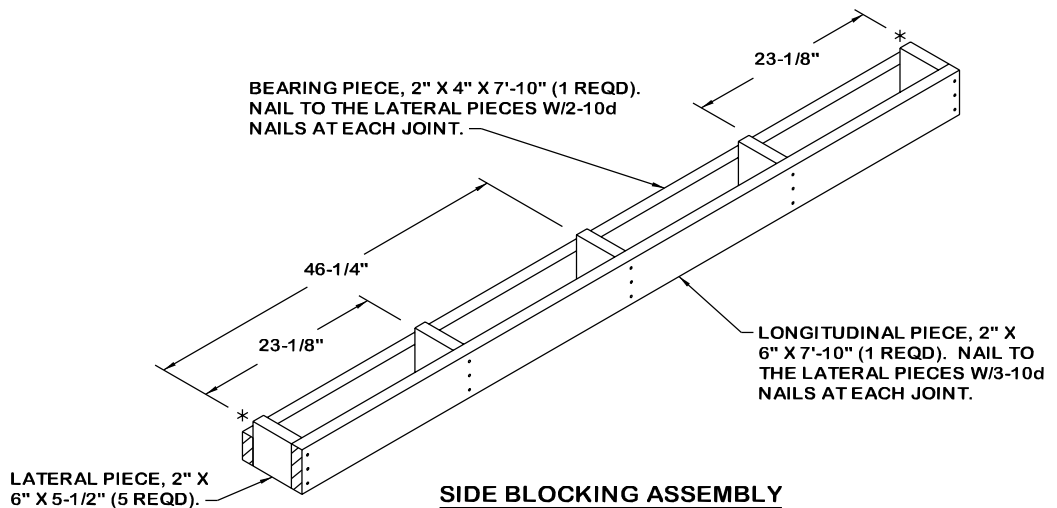

**SIDE BLOCKING ASSEMBLY**

INSTALL WITH THE BEARING PIECE AGAINST THE LADING.

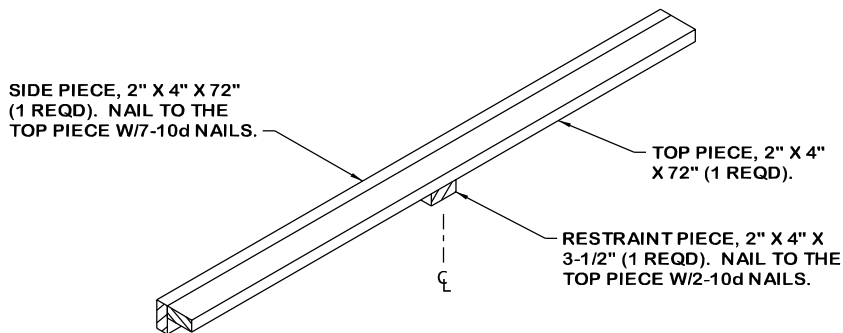

**STRAPPING BOARD ASSEMBLY**

INSTALL WITH THE RESTRAINT PIECE POSITIONED BETWEEN THE TWO LIGHT D541 PALLET UNITS.