

O L K

DATE 1/11/01

APPENDIX 20

LOADING AND BRACING PROCEDURES FOR STRATEGIC CONFIGURED LOAD (SCL) ON CONTAINER ROLL IN/OUT PLATFORM (CROP)

SCL #20 - TOW





INDEX

<u>ITEM</u>	<u>PAGE(S)</u>
TYPICAL LOADING PROCEDURES - - - - -	2
GENERAL NOTES AND SEQUENTIAL LOADING PROCEDURES - - - - -	3
PALLET UNIT DETAIL - - - - -	4
DETAILS - - - - -	5

NOTICE: THIS APPENDIX CANNOT STAND ALONE BUT MUST BE USED IN CONJUNCTION WITH THE BASIC CROP OUTLOADING PROCEDURES DRAWING 19-48-4905-CA17Q6.

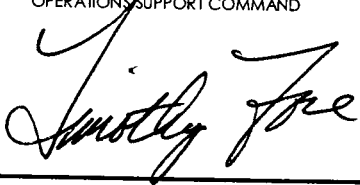
- LOADING AND BRACING SPECIFICATIONS SET FORTH WITHIN THIS DRAWING ARE APPLICABLE TO LOADS THAT ARE TO BE SHIPPED BY TRAILER/CONTAINER-ON-FLATCAR (T/COFC) RAIL CARRIER SERVICE. THESE SPECIFICATIONS MAY ALSO BE USED FOR LOADS THAT ARE TO BE MOVED BY MOTOR OR WATER CARRIERS.

U.S. ARMY MATERIEL COMMAND DRAWING

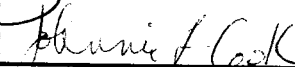
APPROVED, U.S. ARMY OPERATIONS SUPPORT COMMAND 	ENGINEER	BASIC		DO NOT SCALE				
		REV.		WEBSITE: HTTP://WWW.DAC.ARMY.MIL				
	TECHNICIAN	BASIC	PATRICK DOUGHERTY	NOVEMBER 2000				
		REV.						
	DRAFTSMAN	BASIC						
		REV.						
APPROVED BY ORDER OF COMMANDING GENERAL, U.S. ARMY MATERIEL COMMAND 	TRANSPORTATION ENGINEERING DIVISION							
	VALIDATION ENGINEERING DIVISION			TESTED	CLASS	DIVISION	DRAWING	FILE
	ENGINEERING DIRECTORATE				19	48	4905/ 20	CA17Q6

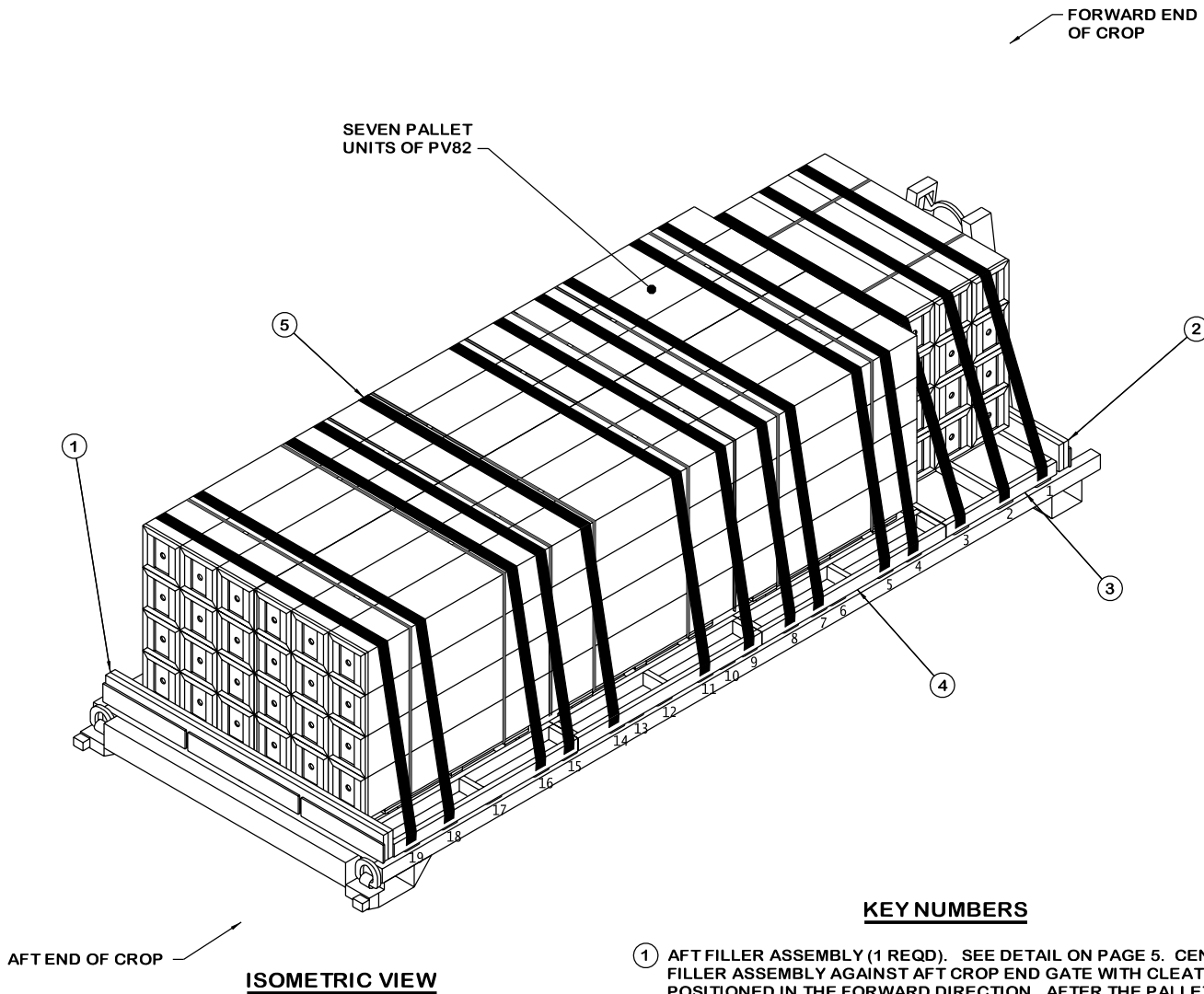

KEY NUMBERS

- ① AFT FILLER ASSEMBLY (1 REQD). SEE DETAIL ON PAGE 5. CENTER FILLER ASSEMBLY AGAINST AFT CROP END GATE WITH CLEATS POSITIONED IN THE FORWARD DIRECTION. AFTER THE PALLET UNITS ARE LOADED, NAIL W/2-12d NAILS THRU THE SLOTS IN THE AFT CROP END GATE INTO THE AFT FILLER ASSEMBLY, LEAVING THE NAIL HEADS PROTRUDING THRU THE SLOTS TO PROVIDE LATERAL RESTRAINT.
- ② FORWARD FILLER, 1" OR 2" X 8" X 7'-4" (AS REQD). LAMINATE BOARDS W/8 NAILS OF SUITABLE SIZE (10d NAILS FOR 2" THICK MATERIAL). POSITION FILLER PIECE AGAINST THE FORWARD CROP END GATE AND CENTER ON THE CROP. AFTER THE PALLET UNITS ARE LOADED, NAIL THROUGH THE HOLES IN THE FORWARD CROP END GATE W/2-12d NAILS INTO THE FORWARD FILLER PIECE, LEAVING THE NAIL HEADS PROTRUDING THROUGH THE HOLES TO PROVIDE LATERAL AND VERTICAL RESTRAINT.
- ③ SPACER ASSEMBLY (2 REQD). SEE DETAIL ON PAGE 5. POSITION THE ASSEMBLIES AT THE FORWARD END OF THE CROP ON EACH SIDE OF THE LATERAL PALLET UNIT. NOTE: NAIL THROUGH THE STRAP ATTACHMENT SLOTS OF THE WEB STRAPS INTO THE SPACER ASSEMBLIES AT TIEDOWN ANCHOR LOCATIONS 1 AND 3 ON EACH SIDE OF THE CROP W/1-10d PARTIALLY DRIVEN NAIL AND BEND OVER SIDE OF HOOK.
- ④ SIDE SPACER ASSEMBLY (6 REQD). SEE DETAIL ON PAGE 5. POSITION THE ASSEMBLIES AGAINST THE PALLET UNITS ON EACH SIDE OF THE CROP AS SHOWN. NOTE: NAIL THROUGH THE STRAP ATTACHMENT SLOTS OF THE WEB STRAPS INTO THE SPACER ASSEMBLIES AT TIEDOWN ANCHOR LOCATIONS 4, 8, 9, 14, 16, AND 19 ON EACH SIDE OF THE CROP W/1-10d PARTIALLY DRIVEN NAIL AND BEND OVER SIDE OF HOOK.
- ⑤ HOLD-DOWN STRAP, 3-INCH WIDE WEB STRAP TIEDOWN ASSEMBLY FOR CROP (14 REQD). INSTALL EACH HOLD-DOWN STRAP TO EXTEND FROM THE DESIGNATED TIEDOWN ANCHOR ON ONE SIDE OF CROP, OVER THE TOP OF THE PALLET UNITS TO THE CORRESPONDING TIEDOWN ANCHOR ON THE OPPOSITE SIDE OF THE CROP. ALIGN SCUFF SLEEVES OVER ALL SHARP EDGES AND FIRMLY TENSION STRAP. SEE GENERAL NOTE "G" ON PAGE 3.

RECOMMENDED SEQUENTIAL PROCEDURES

1. PREFABRICATE THE AFT FILLER ASSEMBLY, TWO SPACER ASSEMBLIES, AND SIX SIDE SPACER ASSEMBLIES.
2. POSITION THE AFT FILLER ASSEMBLY, PIECE MARKED ①, TIGHT AGAINST THE AFT CROP END GATE WITH THE CLEATS FACING FORWARD. CENTER THE FILLER ASSEMBLY ON THE GATE.
3. PLACE TWO PV82 PALLET UNITS ON THE CROP AS SHOWN ON PAGE 2. PALLET UNITS SHALL BE CENTERED ON THE CROP AND TIGHT AGAINST THE AFT FILLER ASSEMBLY WITH THE CLEATS ON THE FILLER ASSEMBLY PROTRUDING UNDER THE TWO PALLET UNITS. NAIL TWO 12d RETAINER NAILS INTO THE AFT FILLER ASSEMBLY AS INSTRUCTED IN KEY NUMBER ①.
4. LOAD TWO PV82 PALLET UNITS SO THAT THE PALLET UNITS ARE CENTERED ON THE CROP AND TIGHT AGAINST THE PREVIOUSLY LOADED ROW OF PALLET UNITS.
5. REPEAT STEP 4.
6. PLACE ONE PV82 PALLET UNIT Laterally ON THE CROP. THE PALLET UNIT SHALL BE CENTERED ON THE CROP AND TIGHT AGAINST THE PREVIOUSLY LOADED PALLET UNITS.
7. CENTER THE FORWARD FILLER AGAINST THE FRONT PALLET UNITS. LAMINATE FILLER PIECES AS REQUIRED. NAIL TWO 12d RETAINER NAILS INTO THE FORWARD FILLER AS INSTRUCTED IN KEY NUMBER ②.
8. INSTALL THE TWO SPACER ASSEMBLIES AS NOTED IN KEY NUMBER ③.
9. INSTALL THE SIX SIDE SPACER ASSEMBLIES AS NOTED IN KEY NUMBER ④.
10. INSTALL THE 14 HOLD-DOWN STRAPS AS NOTED IN KEY NUMBER ⑤.

GENERAL NOTES

- A. THIS APPENDIX CANNOT STAND ALONE BUT MUST BE USED IN CONJUNCTION WITH THE BASIC LOADING PROCEDURES DRAWING 19-48-4905-CA17Q6. TO PRODUCE AN APPROVED LOAD, ALL PERTINENT PROCEDURES, SPECIFICATIONS AND CRITERIA SET FORTH WITHIN THE BASIC DRAWING WILL APPLY TO THE PROCEDURES DELINEATED IN THIS APPENDIX. ANY EXCEPTIONS TO THE BASIC PROCEDURES ARE SPECIFIED IN THIS APPENDIX.
- B. THE OUTLOADING PROCEDURES DEPICTED IN THIS DRAWING ARE APPLICABLE TO LOADS OF SCL #20. SEE PAGE 4 FOR DETAIL OF THE PALLET UNIT. AN M3A1 (HYUNDAI) CROP IS SHOWN AS TYPICAL. OTHER MANUFACTURER'S CROPS CAN BE USED FOR THE LOAD SHOWN ON PAGE 2. THE SEQUENTIAL LOADING PROCEDURES DEPICTED AT LEFT DESCRIBE THE SEQUENCE USED TO LOAD AN M3A1 CROP. FOR AN M3 (SUMMA) CROP, SEQUENTIAL LOADING PROCEDURES 2 THROUGH 7 MUST BE REVERSED. ACTUAL CROP CONFIGURATION WILL DETERMINE WHETHER THE SEQUENTIAL LOADING STARTS AT THE AFT OR THE FORWARD END OF THE CROP.
- C. THE LOADING PROCEDURES DEPICTED HEREIN MAY ALSO BE USED FOR OUTLOADING SIMILAR SCL LOADS WHEN IDENTIFIED BY DIFFERENT NATIONAL STOCK NUMBERS (NSN) THAN WHAT IS SHOWN ON PAGE 4, PROVIDED THE OVERALL PALLET UNIT DIMENSIONS DO NOT VARY FROM WHAT IS DELINEATED HEREIN.
- D. DIMENSIONS, CUBE AND WEIGHT OF THE PALLET UNITS WILL VARY SLIGHTLY DEPENDING UPON THE ACTUAL DIMENSIONS OF THE BOXES AND THE WEIGHT OF THE SPECIFIC ITEM BEING UNITIZED.
- E. ALTERNATE NSN/DODIC COMBINATIONS ARE SHOWN IN THE CHART ON PAGE 4. THESE ALTERNATES MAY BE SUBSTITUTED FOR SOME OR ALL THE DEPICTED NSN/DODICS IF NECESSARY DUE TO THE ITEMS OR QUANTITIES ON HAND.
- F. DIMENSIONS GIVEN FOR DUNNAGE ASSEMBLIES WILL BE FIELD CHECKED PRIOR TO THEIR ASSEMBLY. PALLET UNITS MUST FIT SNUGLY AGAINST THE DUNNAGE ASSEMBLIES. THIS GUIDANCE MUST BE APPLIED PRIOR TO BEGINNING AN OUTLOADING OPERATION. ALSO, DUE TO VARIATION OF PALLET UNIT DIMENSIONS, ADJUSTMENTS MAY BE REQUIRED AS TO THE LOCATION OF CERTAIN PIECES ON DUNNAGE ASSEMBLIES.
- G. ALL WEB STRAP TIEDOWN ASSEMBLIES MUST HAVE THE EXCESS LENGTH OF THE STRAP SECURED. ROLL UP AND BUNDLE THE EXCESS LENGTH OF WEB STRAP, SECURING WITH CABLE TIES. SEE THE "STRAP END SECUREMENT" DETAIL AND GENERAL NOTE "K.12" IN THE BASIC PROCEDURE DRAWING 19-48-4905-CA17Q6.
- H. CONVERSION TO METRIC EQUIVALENTS: DIMENSIONS WITHIN THIS DOCUMENT ARE EXPRESSED IN INCHES, AND WEIGHTS ARE EXPRESSED IN POUNDS. WHEN NECESSARY, THE METRIC EQUIVALENTS MAY BE COMPUTED ON THE BASIS OF ONE INCH EQUALS 25.4MM AND ONE POUND EQUALS 0.454 KG.

BILL OF MATERIAL		
LUMBER	LINEAR FEET	BOARD FEET
2" X 4"	90	60
2" X 8"	30	40
NAILS	NO. REQD	POUNDS
10d (3")	130	2
12d (3-1/4")	4	1/4

LOAD AS SHOWN

ITEM	QUANTITY	WEIGHT (APPROX)
PV82 PALLET UNIT	7	7,784 LBS
DUNNAGE		203 LBS
CROP		3,800 LBS
TOTAL WEIGHT		11,787 LBS (APPROX)

SCL #20 COMPOSITION CHART

DODIC	NSN	NOMENCLATURE	UNIT DWG	REQD	UNITS REQD	HC
PV82 *	1410-01-370-2289	MISSILE, TOW 2B BGM-71F-1	5229	84	7 PALLETS	1. 1E
NOTE: THE DODICS LISTED BELOW MAY BE USED AS ALTERNATES FOR THE DODICS WITH MATCHING SYMBOLS SHOWN ABOVE IF THE QUANTITY OF THE DODICS SHOWN ABOVE IS INSUFFICIENT.						
PD62 *	1410-01-229-9948	MISSILE, TOW 2A BGM-71E	5229			1. 1E
PE96 *	1410-01-300-0254	MISSILE, TOW 2A BGM-71E-1B	5229			1. 1E
PV18 *	1410-01-322-5333	MISSILE, TOW 2B BGM-71F	5229			1. 1E
PV47 *	1410-01-313-5376	MISSILE, TOW 2A BGM-71E-3B	5229			1. 1E

* PALLET UNITS MUST BE UNITIZED IN A THREE WIDE, FOUR HIGH CONFIGURATION AS SHOWN BELOW AND IN ACCORDANCE WITH THE PROVISIONS OF PAGE 4 OF AMC UNITIZATION DRAWING 19-48-5229/GM20T01.

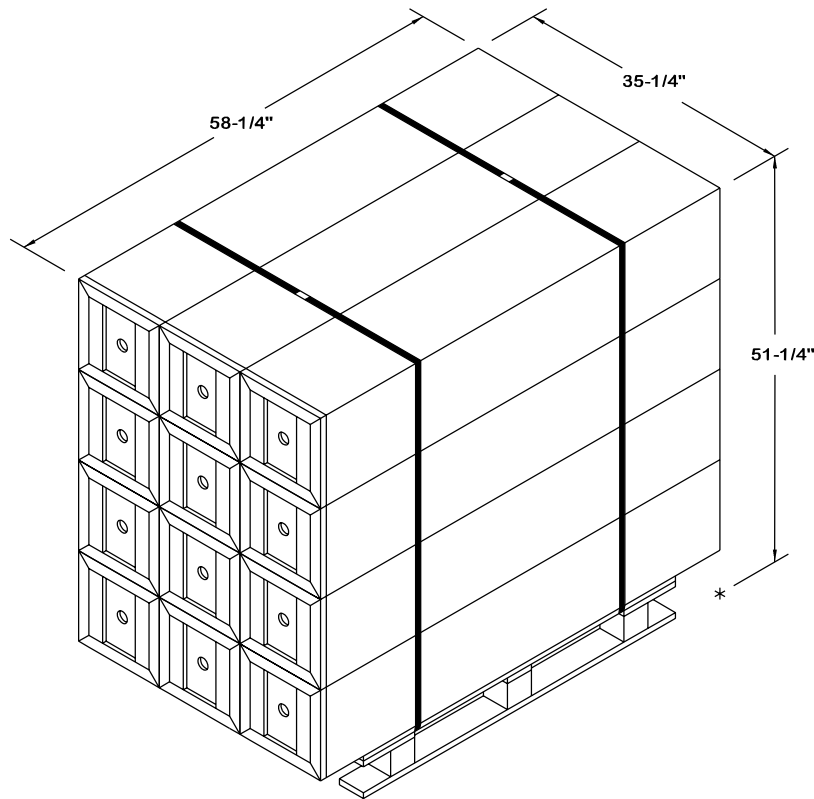

PV82 PALLET UNIT DETAIL

12 BOXES OF TOW MISSILES (1 PER BOX) AT 87 LBS - - - 1,044 LBS (APPROX)
 DUNNAGE - - - - - 3 LBS
 PALLET - - - - - 65 LBS

TOTAL WEIGHT - - - - - 1,112 LBS (APPROX)
 CUBE - - - - - 60.9 CU FT (APPROX)

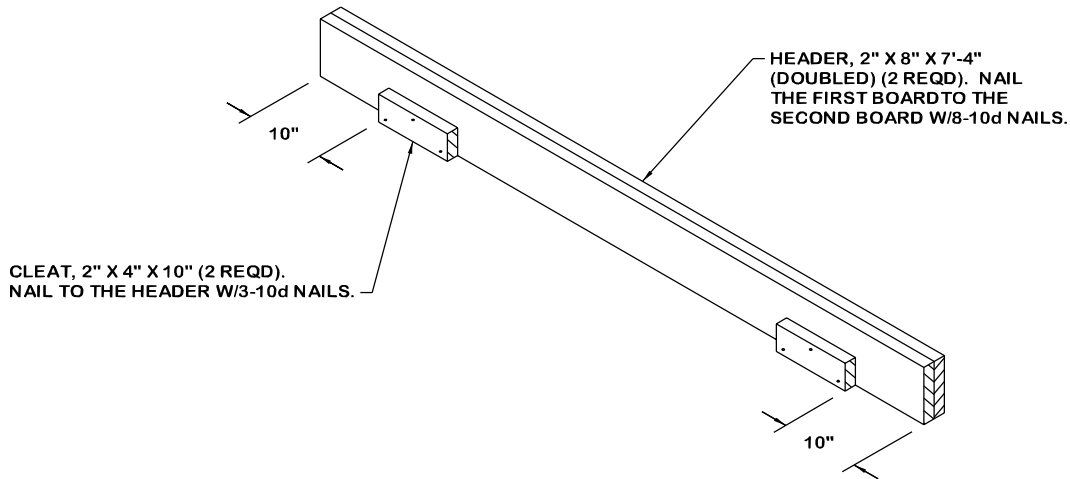

AFT FILLER ASSEMBLY

THIS AFT FILLER ASSEMBLY WILL BE PLACED AT THE REAR OF THE LOAD WITH THE CLEATS RECESSED UNDER THE PALLET UNITS. FIELD CHECK THE ASSEMBLY AGAINST PALLET UNITS TO VERIFY PROPER CLEAT LOCATIONS.

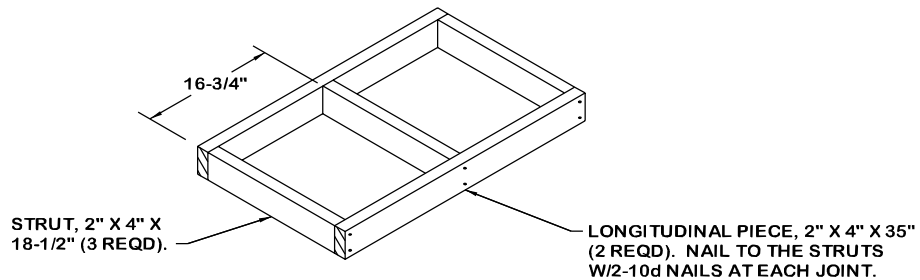

SPACER ASSEMBLY

POSITION A SPACER ASSEMBLY ON EACH SIDE OF THE SINGLE PV82 PALLET UNIT AT THE FORWARD END OF THE CROP AS SHOWN ON PAGE 2.

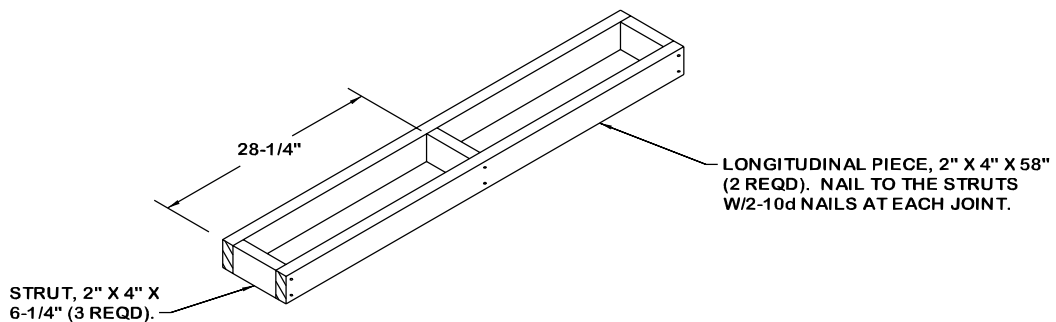

SIDE SPACER ASSEMBLY

POSITION ONE SIDE SPACER ASSEMBLY ON EACH SIDE OF THE THREE ROWS OF PV82 PALLET UNITS AS SHOWN ON PAGE 2.

