

APPROVED BY
BUREAU OF EXPLOSIVES

[Signature]

DATE 1/10/01

APPENDIX 18

LOADING AND BRACING PROCEDURES FOR STRATEGIC CONFIGURED LOAD (SCL) ON CONTAINER ROLL IN/OUT PLATFORM (CROP)

SCL #18 - 120MM APFSDS-T

INDEX

<u>ITEM</u>	<u>PAGE(S)</u>
TYPICAL LOADING PROCEDURES - - - - -	2
GENERAL NOTES AND SEQUENTIAL LOADING PROCEDURES - - - - -	3
PALLET UNIT DETAILS - - - - -	4-5
DETAILS - - - - -	5-6

NOTICE: THIS APPENDIX CANNOT STAND ALONE BUT MUST BE USED IN CONJUNCTION WITH THE BASIC CROP OUTLOADING PROCEDURES DRAWING 19-48-4905-CA17Q6.

- LOADING AND BRACING SPECIFICATIONS SET FORTH WITHIN THIS DRAWING ARE APPLICABLE TO LOADS THAT ARE TO BE SHIPPED BY TRAILER/CONTAINER-ON-FLATCAR (T/COFC) RAIL CARRIER SERVICE. THESE SPECIFICATIONS MAY ALSO BE USED FOR LOADS THAT ARE TO BE MOVED BY MOTOR OR WATER CARRIERS.

U.S. ARMY MATERIEL COMMAND DRAWING

APPROVED, U.S. ARMY OPERATIONS SUPPORT COMMAND <i>[Signature: Timothy Fore]</i>	ENGINEER	BASIC	RICHARD GARSIDE	DO NOT SCALE			
		REV.		WEBSITE: HTTP://WWW.DAC.ARMY.MIL			
	TECHNICIAN	BASIC		OCTOBER 2000			
		REV.					
	DRAFTSMAN	BASIC					
		REV.					
APPROVED BY ORDER OF COMMANDING GENERAL, U.S. ARMY MATERIEL COMMAND <i>[Signature: J. Q. White]</i> U.S. ARMY DEFENSE AMMUNITION CENTER	TRANSPORTATION ENGINEERING DIVISION		<i>[Signature: Gregory L. Willis]</i>				
	VALIDATION ENGINEERING DIVISION		<i>[Signature: ...]</i>	CLASS	DIVISION	DRAWING	FILE
	ENGINEERING DIRECTORATE		<i>[Signature: ...]</i>	19	48	4905/ 18	CA17Q6

PROJECT CAP-TV 6/18-00

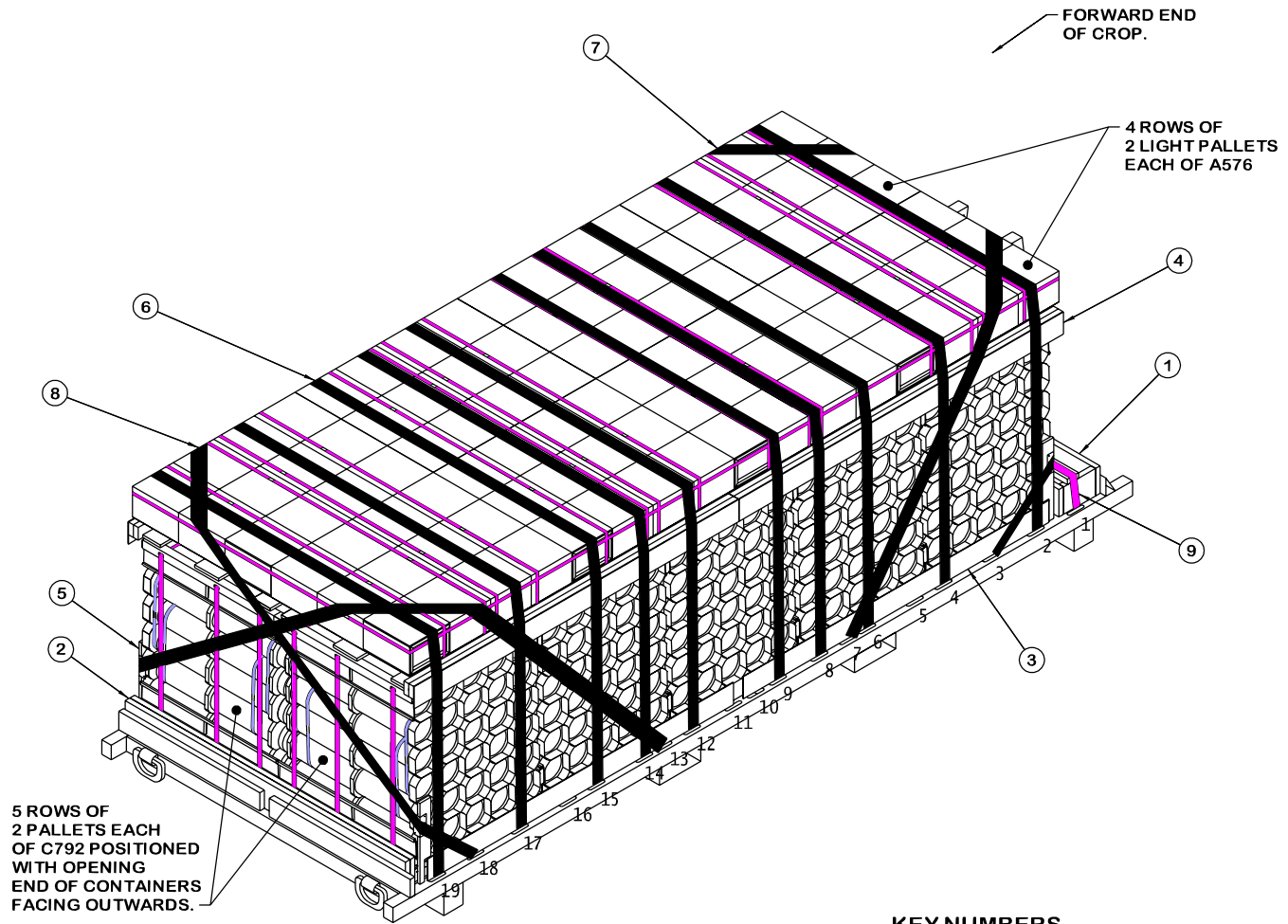

ISOMETRIC VIEW

KEY NUMBERS

- ① FORWARD BLOCKING ASSEMBLY (1 REQD). SEE DETAIL ON PAGE 5. CENTER AGAINST FORWARD CROP END GATE. AFTER PALLET UNITS ARE LOADED, NAIL THROUGH THE SLOTS IN THE FORWARD CROP END GATE INTO THE FORWARD BLOCKING ASSEMBLY W/2-12d NAILS. LEAVE THE NAIL HEADS PROTRUDING THROUGH THE SLOTS TO PROVIDE LATERAL RESTRAINT.
- ② AFT FILLER, 1" OR 2" X 8" X 7'-4" (AS REQD). LAMINATE EACH PIECE TO THE PREVIOUS PIECE W/8 NAILS OF A SUITABLE SIZE (6d NAILS FOR 1" THICK MATERIAL OR 10d NAILS FOR 2" THICK MATERIAL). CENTER AGAINST AFT CROP END GATE AND NAIL THROUGH THE SLOTS IN THE AFT CROP END GATE INTO THE AFT FILLER W/2-12d NAILS. LEAVE THE NAIL HEADS PROTRUDING THROUGH THE SLOTS TO PROVIDE LATERAL AND VERTICAL RESTRAINT.
- ③ SIDE BLOCKING ASSEMBLY (4 REQD). SEE DETAIL ON PAGE 6. INSTALL TWO ON EACH SIDE OF THE CROP ADJACENT TO THE C792 PALLET UNITS.
- ④ SIDE STRAPPING BOARD ASSEMBLY (4 REQD). SEE DETAIL ON PAGE 6. INSTALL TWO ON EACH SIDE OF THE CROP, ON THE EDGES OF THE C792 PALLET UNITS.
- ⑤ CORNER STRAPPING BOARD ASSEMBLY (4 REQD). SEE DETAIL ON PAGE 6. INSTALL TWO EACH OF ASSEMBLY A AND ASSEMBLY B, ON THE CORNERS OF THE C792 PALLET UNITS, WITH BASE OF ASSEMBLY AGAINST DECK OF CROP AND BEARING PIECE ALONG SIDE OF LOAD.
- ⑥ HOLD-DOWN STRAP, 3-INCH WIDE CROP STRAP (10 REQD). INSTALL EACH STRAP TO EXTEND FROM THE DESIGNATED TIEDOWN ANCHOR ON ONE SIDE OF CROP, OVER THE TOP OF THE PALLET UNITS, TO THE CORRESPONDING TIEDOWN ANCHOR ON THE OPPOSITE SIDE OF THE CROP. ALIGN SCUFF SLEEVES OVER ALL SHARP EDGES AND FIRMLY TENSION STRAP. SEE GENERAL NOTE "H" ON PAGE 3.

(KEY NUMBERS CONTINUED)

- ⑦ FORWARD END RESTRAINT STRAP, 3-INCH WIDE CROP STRAP (2 REQD). INSTALL EACH STRAP TO EXTEND FROM THE THIRD TIEDOWN ANCHOR ON ONE SIDE OF CROP, AROUND THE SIDE OF THE FORWARD C792 PALLET UNITS, OVER THE TOP OF THE FORWARD A576 PALLET UNITS, TO THE SEVENTH TIEDOWN ANCHOR ON THE OPPOSITE SIDE OF THE CROP. ALIGN SCUFF SLEEVES OVER ALL SHARP EDGES AND FIRMLY TENSION STRAP. SEE GENERAL NOTE "H" ON PAGE 3.
- ⑧ AFT END RESTRAINT STRAP, 3-INCH WIDE CROP STRAP (2 REQD). INSTALL EACH STRAP TO EXTEND FROM THE EIGHTEENTH TIEDOWN ANCHOR ON ONE SIDE OF CROP, AROUND THE SIDE OF THE AFT C792 PALLET UNITS, OVER THE TOP OF THE AFT A576 PALLET UNITS, TO THE THIRTEENTH TIEDOWN ANCHOR ON THE OPPOSITE SIDE OF THE CROP. ALIGN SCUFF SLEEVES OVER ALL SHARP EDGES AND FIRMLY TENSION STRAP. SEE GENERAL NOTE "H" ON PAGE 3.
- ⑨ RETAINER STRAP, 2-INCH WIDE WEB STRAP ASSEMBLY (1 REQD). INSTALL TO EXTEND FROM THE FIRST TIEDOWN ANCHOR ON ONE SIDE OF CROP, OVER TOP OF THE FORWARD BLOCKING ASSEMBLY STRAPPING BOARD, TO THE FIRST TIEDOWN ANCHOR ON OPPOSITE SIDE OF CROP. ALIGN SCUFF SLEEVES OVER ALL SHARP EDGES AND FIRMLY TENSION STRAP. SEE GENERAL NOTE "H" ON PAGE 3.

(CONTINUED AT LEFT)

RECOMMENDED SEQUENTIAL PROCEDURES

1. PREFABRICATE THE AFT FILLER PIECES, FORWARD BLOCKING ASSEMBLY, FOUR SIDE STRAPPING BOARD ASSEMBLIES, FOUR CORNER STRAPPING BOARD ASSEMBLIES, AND FOUR SIDE BLOCKING ASSEMBLIES.
2. INSTALL THE FORWARD BLOCKING ASSEMBLY. ALIGN STRAPPING BOARD TO FIRST TIEDOWN ANCHOR AND NAIL TO STRUTS. INSTALL RETAINER STRAP.
3. LOAD FIVE ROWS OF TWO PALLET UNITS OF C792 AGAINST THE FORWARD BLOCKING ASSEMBLY, CENTERING THE ROWS LATERALLY ON THE CROP AND POSITIONING TIGHT AGAINST THE ADJACENT PALLET UNITS.
4. INSTALL THE AFT FILLER PIECES TO ENSURE A TIGHT FIT BETWEEN PALLET UNITS AND AFT CROP END GATE.
5. LOAD FOUR ROWS OF TWO A576 LIGHT PALLET UNITS ON TOP OF THE C792 PALLET UNITS, CENTERING EACH ROW LATERALLY ON THE CROP AND POSITIONING TIGHT AGAINST THE ADJACENT PALLET UNITS.
6. PLACE THE SIDE STRAPPING BOARD ASSEMBLIES ON THE EDGES OF THE C792 PALLET UNITS AND AGAINST THE PALLETS OF THE A576 LIGHT PALLET UNITS.
7. INSTALL THE FOUR SIDE BLOCKING ASSEMBLIES, TWO ON EACH SIDE OF LOAD AS SHOWN.
8. INSTALL CORNER STRAPPING BOARD ASSEMBLIES ON THE CORNERS OF THE FORWARD AND AFT C792 PALLET UNITS, WITH THE BASE OF THE ASSEMBLIES RESTING ON THE DECK OF THE CROP.
9. INSTALL 10 HOLD-DOWN STRAPS TO EXTEND FROM A TIEDOWN ANCHOR ON ONE SIDE OF THE CROP, OVER THE TOP OF THE PALLET UNITS, TO THE CORRESPONDING TIEDOWN ANCHOR ON THE OPPOSITE SIDE OF THE CROP.
10. INSTALL TWO FORWARD END RESTRAINT STRAPS TO EXTEND FROM THE THIRD TIEDOWN ANCHOR ON ONE SIDE OF CROP, AROUND THE SIDE OF THE FORWARD C792 PALLET UNITS, OVER THE TOP OF THE FORWARD A576 LIGHT PALLET UNITS, TO THE SEVENTH TIEDOWN ANCHOR ON THE OPPOSITE SIDE OF THE CROP.
11. INSTALL TWO AFT END RESTRAINT STRAPS TO EXTEND FROM THE EIGHTEENTH TIEDOWN ANCHOR ON ONE SIDE OF CROP, AROUND THE SIDE OF THE AFT C792 PALLET UNITS, OVER THE TOP OF THE AFT A576 LIGHT PALLET UNITS, TO THE THIRTEENTH TIEDOWN ANCHOR ON THE OPPOSITE SIDE OF THE CROP.
12. NAIL TWO 12d RETAINING NAILS THRU THE SLOTS IN THE AFT CROP END GATE INTO THE AFT FILLER PIECE, LEAVING THE NAIL HEADS PROTRUDING THRU THE SLOTS TO PROVIDE LATERAL AND VERTICAL RESTRAINT.
13. NAIL THE TWO REMAINING 12d RETAINING NAILS THRU THE SLOTS IN THE FORWARD CROP END GATE INTO THE FORWARD BLOCKING ASSEMBLY, LEAVING THE NAIL HEADS PROTRUDING THRU THE SLOTS TO PROVIDE LATERAL RESTRAINT.

GENERAL NOTES

- A. THIS APPENDIX CANNOT STAND ALONE BUT MUST BE USED IN CONJUNCTION WITH THE BASIC LOADING PROCEDURES DRAWING 19-48-4905-CA17Q6. TO PRODUCE AN APPROVED LOAD, ALL PERTINENT PROCEDURES, SPECIFICATIONS AND CRITERIA SET FORTH WITHIN THE BASIC DRAWING WILL APPLY TO THE PROCEDURES DELINEATED IN THIS APPENDIX. ANY EXCEPTIONS TO THE BASIC PROCEDURES ARE SPECIFIED IN THIS APPENDIX.
- B. THE OUTLOADING PROCEDURES DEPICTED IN THIS DRAWING ARE APPLICABLE TO LOADS OF SCL #18. SEE PAGES 4 AND 5 FOR DETAILS OF THE PALLET UNITS. AN M3 (SUMMA) CROP IS SHOWN AS TYPICAL. OTHER MANUFACTURER'S CROPS CAN BE USED FOR THE LOAD SHOWN ON PAGE 2. THE SEQUENTIAL LOADING PROCEDURES DEPICTED AT LEFT DESCRIBE THE SEQUENCE USED TO LOAD AN M3 CROP. FOR AN M3A1 (HYUNDAI) CROP, SEQUENTIAL LOADING PROCEDURES 2 THROUGH 4 MUST BE REVERSED. ACTUAL CROP CONFIGURATION WILL DETERMINE WHETHER THE SEQUENTIAL LOADING STARTS AT THE AFT OR THE FORWARD END OF THE CROP.
- C. THE LOADING PROCEDURES DEPICTED HEREIN MAY ALSO BE USED FOR OUTLOADING SIMILAR SCL LOADS WHEN IDENTIFIED BY DIFFERENT NATIONAL STOCK NUMBERS (NSN) THAN WHAT IS SHOWN ON PAGE 4, PROVIDED THE OVERALL PALLET UNIT DIMENSIONS DO NOT VARY FROM WHAT IS DELINEATED HEREIN.
- D. LIGHT PALLET UNITS MUST BE CONSTRUCTED IN ACCORDANCE WITH THE GUIDELINES DELINEATED IN THE BASIC UNITIZATION PROCEDURES DRAWING APPLICABLE TO THAT PALLET UNIT.
- E. DIMENSIONS, CUBE AND WEIGHT OF THE PALLET UNITS WILL VARY SLIGHTLY DEPENDING UPON THE ACTUAL DIMENSIONS OF THE BOXES AND THE WEIGHT OF THE SPECIFIC ITEM BEING UNITIZED.
- F. ALTERNATE NSN/DODIC COMBINATIONS ARE SHOWN IN THE CHART ON PAGE 4. THESE ALTERNATES MAY BE SUBSTITUTED FOR SOME OR ALL THE DEPICTED NSN/DODICS IF NECESSARY DUE TO THE ITEMS OR QUANTITIES ON HAND.
- G. DIMENSIONS GIVEN FOR DUNNAGE ASSEMBLIES WILL BE FIELD CHECKED PRIOR TO THEIR ASSEMBLY. PALLET UNITS MUST FIT SNUGLY AGAINST THE DUNNAGE ASSEMBLIES. THIS GUIDANCE MUST BE APPLIED PRIOR TO BEGINNING AN OUTLOADING OPERATION. ALSO, DUE TO VARIATION OF PALLET UNIT DIMENSIONS, ADJUSTMENTS MAY BE REQUIRED AS TO THE LOCATION OF CERTAIN PIECES ON DUNNAGE ASSEMBLIES.
- H. ALL WEB STRAP TIEDOWN ASSEMBLIES MUST HAVE THE EXCESS LENGTH OF THE STRAP SECURED. ROLL UP AND BUNDLE THE EXCESS LENGTH OF WEB STRAP, SECURING WITH CABLE TIES. SEE THE "STRAP END SECUREMENT" DETAIL AND GENERAL NOTE "K.12" IN THE BASIC PROCEDURE DRAWING 19-48-4905-CA17Q6.
- J. CONVERSION TO METRIC EQUIVALENTS: DIMENSIONS WITHIN THIS DOCUMENT ARE EXPRESSED IN INCHES, AND WEIGHTS ARE EXPRESSED IN POUNDS. WHEN NECESSARY, THE METRIC EQUIVALENTS MAY BE COMPUTED ON THE BASIS OF ONE INCH EQUALS 25.4MM AND ONE POUND EQUALS 0.454 KG.

BILL OF MATERIAL

LUMBER	LINEAR FEET	BOARD FEET
1" x 4"	8	3
2" x 4"	82	55
1" x 8"	8	6
2" x 8"	26	35
NAILS	NO. REQD	POUNDS
6d (2")	108	3/4
10d (3")	72	1
12d (3-1/4")	4	NIL
2" WEB STRAP TIEDOWN ASSEMBLY - 1 REQD - - - 6 LBS		
HARDBOARD, 1/8" THICK - 32 SQ FT - - - - - 12 LBS		
2" STEEL EDGE PROTECTOR - 8 REQD - - - - - 1/2 LBS		

LOAD AS SHOWN

ITEM	QUANTITY	WEIGHT (APPROX)
A576 PALLET UNIT - - -	8 - - - - -	7,888 LBS
C792 PALLET UNIT - - -	10 - - - - -	22,640 LBS
DUNNAGE - - - - -	- - - - -	219 LBS
CROP - - - - -	- - - - -	3,800 LBS
TOTAL WEIGHT - - - - -		34,547 LBS (APPROX)

SCL #18 COMPOSITION CHART

DODIC	NSN	NOMENCLATURE	UNIT DWG	REQD	UNITS REQD	HC
A576 *	1305-00-028-6603	CTG, CAL .50 4 API M8/1 API-T M20 LINKED	4116/14	19,200	8 LT PLTS	1.4G
C792 ^	1315-01-361-5023	CTG, 120MM APFSDS-T M829A2	4231/48	300	10 PALLETS	1.2C

NOTE: THE DODICS LISTED BELOW MAY BE USED AS ALTERNATES FOR THE DODICS WITH MATCHING SYMBOLS SHOWN ABOVE IF THE QUANTITY OF THE DODICS SHOWN ABOVE IS INSUFFICIENT.

A540 *	1305-00-935-2017	CTG, CAL .50 4 API M8/1 TR M17 LINKED	4116/14			1.4G
C380 ^	1315-01-268-2256	CTG, 120MM APFSDS-T M829A1	4231/48			1.2C

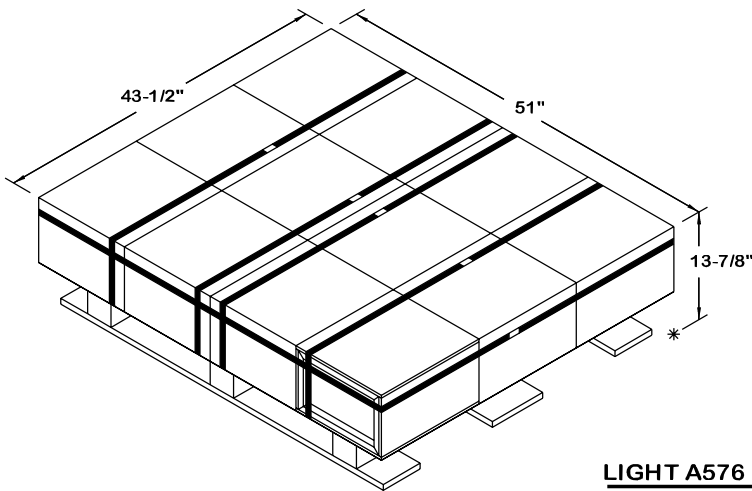

THE A576 LIGHT PALLET UNIT SHOULD BE CONSTRUCTED IAW THE AMC DRAWING LISTED ABOVE WITH THE FOLLOWING CHANGES:

1. ELIMINATE THREE LAYERS OF BOXES (36 BOXES).
2. ELIMINATE THREE HORIZONTAL STRAPS.
3. REDUCE THE TIEDOWN STRAP LENGTH TO 9'-9".

LIGHT A576 PALLET UNIT DETAIL

12 BOXES OF .50 CAL CTG (200 PER BOX) AT 75 LBS - - -	900 LBS (APPROX)
DUNNAGE - - - - -	6 LBS
PALLET - - - - -	80 LBS
<hr style="border: 0.5px solid black;"/>	
TOTAL WEIGHT - - - - -	986 LBS (APPROX)
CUBE - - - - -	17.8 CU FT (APPROX)

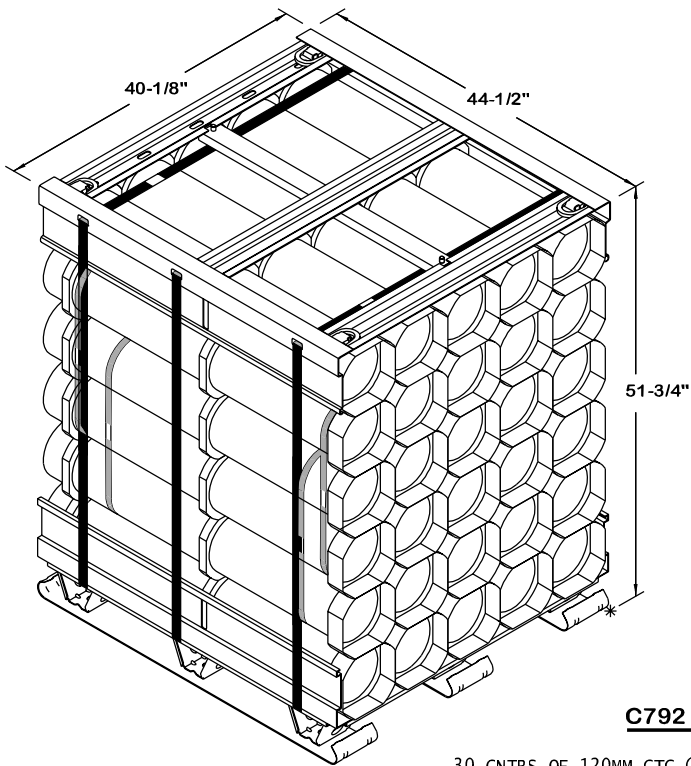

C792 PALLET UNIT DETAIL

30 CNTRS OF 120MM CTG (1 PER CNTR) AT 69 LBS	- - - - -	2,070 LBS (APPROX)
DUNNAGE	- - - - -	89 LBS
PALLET	- - - - -	105 LBS
<hr/>		
TOTAL WEIGHT	- - - - -	2,264 LBS (APPROX)
CUBE	- - - - -	53.5 CU FT (APPROX)

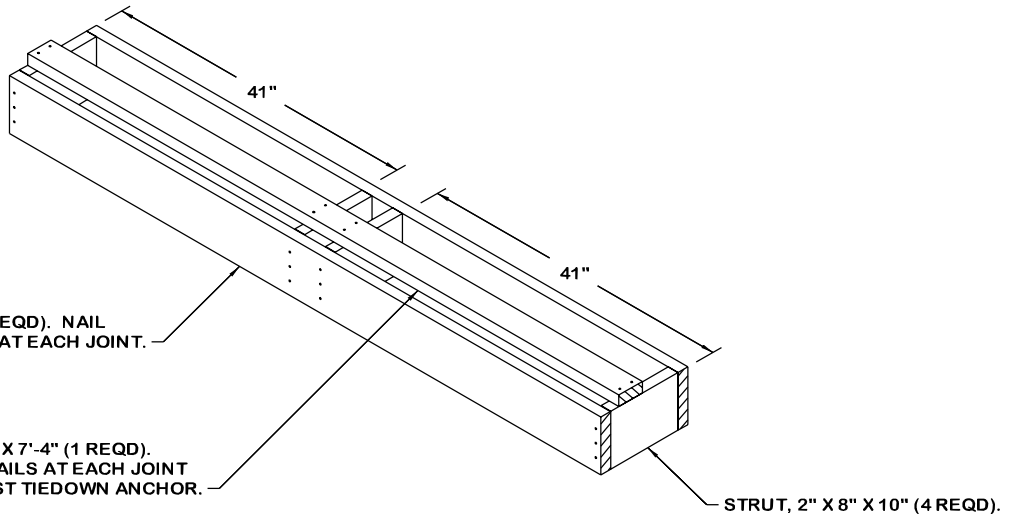

HEADER, 2" X 8" X 7'-4" (2 REQD). NAIL TO STRUTS W/3-10d NAILS AT EACH JOINT.

STRAPPING BOARD, 2" X 4" X 7'-4" (1 REQD). NAIL TO STRUTS W/2-10d NAILS AT EACH JOINT AFTER ALIGNING WITH FIRST TIEDOWN ANCHOR.

STRUT, 2" X 8" X 10" (4 REQD).

FORWARD BLOCKING ASSEMBLY

NOTE: PRODUCE EQUAL QUANTITIES OF ASSEMBLY A AND ASSEMBLY B. EACH CROP LOAD REQUIRES TWO OF EACH (4 TOTAL).

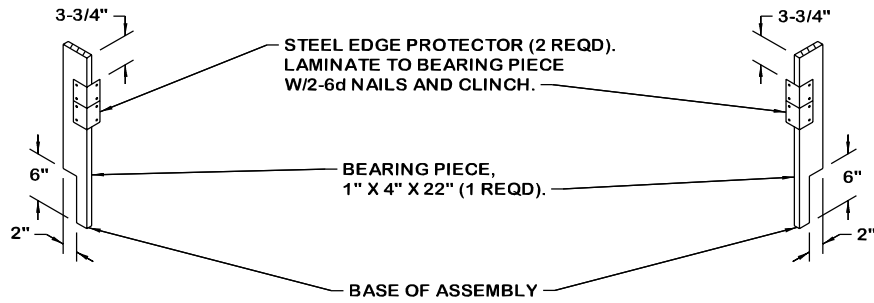

CORNER STRAPPING BOARD ASSEMBLY A

CORNER STRAPPING BOARD ASSEMBLY B

BEARING PIECE, 2" X 4" X 8'-6" (2 REQD).
NAIL FIRST PIECE TO SECOND PIECE
W/8-10d NAILS.

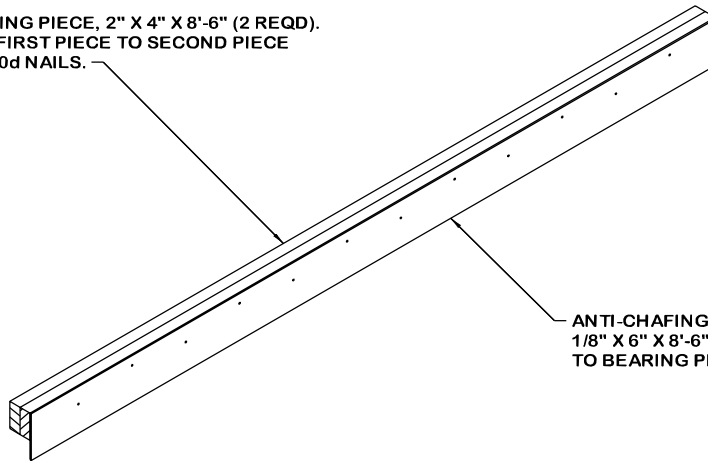

SIDE STRAPPING BOARD ASSEMBLY

NOTE: FOR ALL DUNNAGE USING 1/8" HARDBOARD MATERIAL, LUAN UNDERLAYMENT (3/16" THICK) MAY BE SUBSTITUTED IF SUFFICIENT HARDBOARD MATERIAL IS UNAVAILABLE.

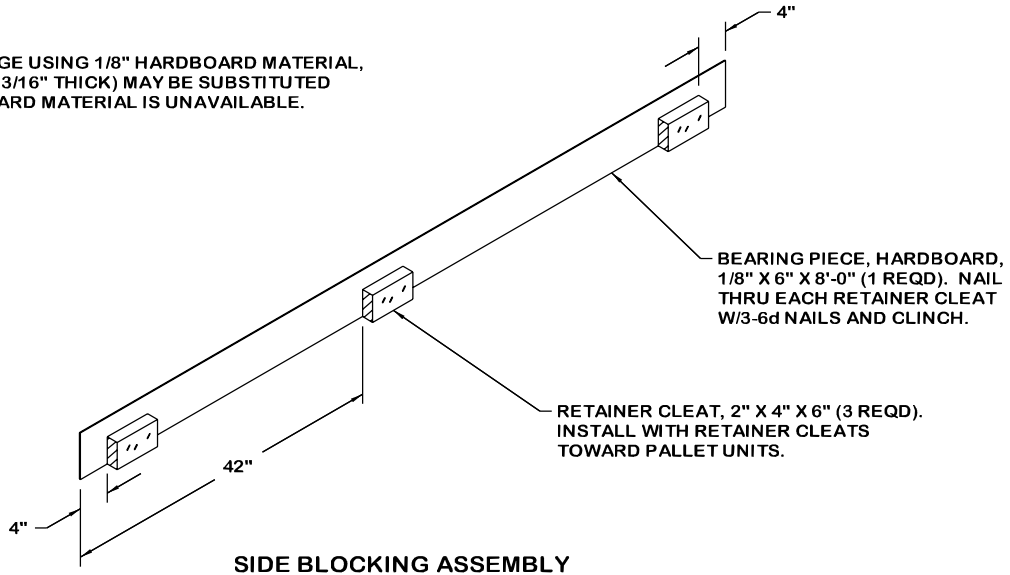

SIDE BLOCKING ASSEMBLY