

*J - 1/L*

DATE *11/11/01*

# APPENDIX 16B

## LOADING AND BRACING PROCEDURES FOR STRATEGIC CONFIGURED LOAD (SCL) ON CONTAINER ROLL IN/OUT PLATFORM (CROP)

### SCL #16B - 40MM HEDP M430





#### INDEX

<u>ITEM</u>	<u>PAGE(S)</u>
TYPICAL LOADING PROCEDURES - - - - -	2
GENERAL NOTES AND SEQUENTIAL LOADING PROCEDURES - - - - -	3
PALLET UNIT DETAILS - - - - -	4
DETAILS - - - - -	5, 6

**NOTICE: THIS APPENDIX CANNOT STAND ALONE BUT MUST BE USED IN CONJUNCTION WITH THE BASIC CROP OUTLOADING PROCEDURES DRAWING 19-48-4905-CA17Q6.**

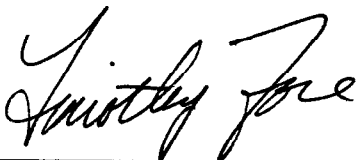
- LOADING AND BRACING SPECIFICATIONS SET FORTH WITHIN THIS DRAWING ARE APPLICABLE TO LOADS THAT ARE TO BE SHIPPED BY TRAILER/CONTAINER-ON-FLATCAR (T/COFC) RAIL CARRIER SERVICE. THESE SPECIFICATIONS MAY ALSO BE USED FOR LOADS THAT ARE TO BE MOVED BY MOTOR OR WATER CARRIERS.

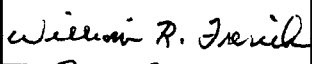
### U.S. ARMY MATERIEL COMMAND DRAWING

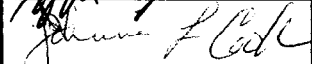
APPROVED, U.S. ARMY OPERATIONS SUPPORT COMMAND  	ENGINEER	BASIC	WALTER GORDON		DO NOT SCALE			
		REV.			WEBSITE: <a href="http://www.dac.army.mil">HTTP://WWW.DAC.ARMY.MIL</a>			
	TECHNICIAN	BASIC			NOVEMBER 2000			
		REV.						
	DRAFTSMAN	BASIC						
		REV.						
APPROVED BY ORDER OF COMMANDING GENERAL, U.S. ARMY MATERIEL COMMAND    U.S. ARMY DEFENSE AMMUNITION CENTER	TRANSPORTATION ENGINEERING DIVISION							
	VALIDATION ENGINEERING DIVISION	 TESTED			CLASS	DIVISION	DRAWING	FILE
	ENGINEERING DIRECTORATE				19	48	4905/ 16B	CA17Q6

FOUR LIGHT PALLET  
UNITS OF A131

FORWARD END  
OF CROP.

FOUR PALLET  
UNITS OF B542

FOUR PALLET  
UNITS OF B542

1

2

4

8

AFT END OF CROP.

FOUR LIGHT PALLET  
UNITS OF A064

7

5

3

9

### ISOMETRIC VIEW

### KEY NUMBERS

(KEY NUMBERS CONTINUED)

- ⑦ HOLD-DOWN STRAP, 3-INCH WIDE WEB STRAP TIEDOWN ASSEMBLY FOR CROP (10 REQD). INSTALL EACH HOLD-DOWN STRAP TO EXTEND FROM THE DESIGNATED TIEDOWN ANCHOR ON ONE SIDE OF CROP, OVER TOP OF PALLET UNITS, TO CORRESPONDING TIEDOWN ANCHOR ON OPPOSITE SIDE OF CROP. ALIGN SCUFF SLEEVES OVER ALL SHARP EDGES AND FIRMLY TENSION STRAP. SEE GENERAL NOTE "G" ON PAGE 3.
- ⑧ FORWARD END RESTRAINT STRAP, 3-INCH WIDE WEB STRAP TIEDOWN ASSEMBLY FOR CROP (2 REQD). INSTALL EACH STRAP FROM THE SIXTH TIEDOWN ANCHOR ON ONE SIDE OF THE CROP (ONE ON EACH SIDE), OVER THE FORWARD B542 AND LIGHT A131 PALLET UNITS AND BACK DOWN TO THE THIRD TIEDOWN ANCHOR ON THE OPPOSITE SIDE OF THE CROP. ALIGN SCUFF SLEEVES OVER ALL SHARP EDGES AND FIRMLY TENSION STRAP. SEE GENERAL NOTE "G" ON PAGE 3.
- ⑨ AFT END RESTRAINT STRAP, 3-INCH WIDE WEB STRAP TIEDOWN ASSEMBLY FOR CROP (2 REQD). INSTALL EACH STRAP FROM THE SIXTEENTH TIEDOWN ANCHOR ON ONE SIDE OF THE CROP (ONE ON EACH SIDE), OVER THE LIGHT A064 AND AFT B542 PALLET UNITS AND EDGE BOARD ASSEMBLY, BACK DOWN TO THE THIRTEENTH TIEDOWN ANCHOR ON THE OPPOSITE SIDE OF THE CROP. ALIGN SCUFF SLEEVES OVER ALL SHARP EDGES AND FIRMLY TENSION STRAP. SEE GENERAL NOTE "G" ON PAGE 3.

- ① FORWARD BLOCKING ASSEMBLY (1 REQD). SEE THE DETAIL ON PAGE 5. CENTER ON THE DECK OF THE CROP AGAINST THE FORWARD END GATE.
- ② AFT BLOCKING ASSEMBLY (1 REQD). SEE THE DETAIL ON PAGE 5. AFTER THE PALLETES ARE LOADED, CENTER ON THE DECK OF THE CROP AGAINST THE AFT END GATE. ANY REMAINING GAP BETWEEN THE END BLOCKING AND THE CROP END GATE MUST BE FILLED BY LAMINATING ADDITIONAL 1" OR 2" X 8" X 7'-4" PIECES TO THE END BLOCKING W/8 NAILS OF A SUITABLE SIZE. NAIL TWO 12d NAILS THRU UPPER CORNER OF OPENING IN AFT END GATES INTO THE AFT BLOCKING ASSEMBLY, WITH NAIL HEADS PROTRUDING AND BENT OVER VERTICAL TUBE OF END GATE TO PROVIDE LATERAL AND VERTICAL RESTRAINT.
- ③ RETAINER STRAP, 2-INCH WIDE WEB STRAP TIEDOWN ASSEMBLY (1 REQD). INSTALL TO EXTEND FROM A TIEDOWN RING ON SIDE OF CROP, OVER TOP OF STRAPPING BOARD OF END BLOCKING ASSEMBLY, TO CORRESPONDING TIEDOWN RING ON OPPOSITE SIDE OF CROP. POSITION STRAP SCUFF SLEEVES AT SHARP EDGES. TAKE UP EXCESS SLACK IN STRAP AND THEN RATCHET TIGHT. SEE GENERAL NOTE "G" ON PAGE 3.
- ④ SIDE FILL, 4" X 4" X 8'-3" (2 REQD). INSTALL ONE ON EACH SIDE OF CROP ADJACENT TO THE FORWARD FOUR B542 PALLET UNITS. SEE GENERAL NOTE "H" ON PAGE 3.
- ⑤ SIDE BLOCKING ASSEMBLY, 1" X 4" X 8'-6" AND 2" X 4" X 8'-6" (2 REQD). LAMINATE THE 1" THICK MATERIAL TO THE 2" THICK MATERIAL W/9-6d NAILS, EVENLY SPACED, TO FORM ONE ASSEMBLY. INSTALL ONE ASSEMBLY ON EACH SIDE OF CROP ADJACENT TO THE A064 PALLET UNITS. SEE GENERAL NOTE "H" ON PAGE 3.
- ⑥ EDGE BOARD ASSEMBLY (2 REQD). SEE THE DETAIL ON PAGE 6. INSTALL ONE ASSEMBLY AT EACH EDGE OF THE AFT FOUR B542 PALLET UNITS AS SHOWN.

(CONTINUED AT LEFT)

**RECOMMENDED SEQUENTIAL PROCEDURES**

1. PREFABRICATE THE FORWARD AND AFT END BLOCKING ASSEMBLIES, TWO SIDE BLOCKING ASSEMBLIES, AND THE TWO EDGE BOARD ASSEMBLIES.
2. INSTALL THE FORWARD BLOCKING ASSEMBLY AS INSTRUCTED IN KEY NUMBER ①.
3. LOAD FOUR PALLET UNITS OF B542. CENTER THE PALLET UNITS ON THE DECK OF THE CROP AND PLACE TIGHTLY AGAINST THE FORWARD BLOCKING ASSEMBLY.
4. LOAD FOUR LIGHT PALLET UNITS OF A064. CENTER THE LIGHT PALLET UNITS ON THE DECK OF THE CROP AND PLACE TIGHTLY AGAINST THE FORWARD B542 PALLET UNITS.
5. LOAD THE REMAINING FOUR PALLET UNITS OF B542. CENTER THE PALLET UNITS ON THE A064 LIGHT PALLET UNITS AND PLACE THEM TIGHT AGAINST THE FORWARD B542 PALLET UNITS.
6. LOAD FOUR LIGHT PALLET UNITS OF A131. CENTER THE LIGHT PALLET UNITS ON THE FORWARD B542 PALLET UNITS AND PLACE THEM TIGHT AGAINST THE AFT B542 PALLET UNITS.
7. INSTALL THE AFT BLOCKING ASSEMBLY AS INSTRUCTED IN KEY NUMBER ②.
8. INSTALL ONE 2" RETAINER STRAP OVER THE AFT BLOCKING ASSEMBLY. REFER TO KEY NUMBER ③.
9. INSTALL THE TWO SIDE FILL PIECES AS INSTRUCTED IN KEY NUMBER ④.
10. INSTALL THE TWO SIDE BLOCKING ASSEMBLIES AS INSTRUCTED IN KEY NUMBER ⑤.
11. INSTALL TWO EDGE BOARD ASSEMBLIES.
12. INSTALL TEN 3-INCH WEB STRAP TIEDOWN ASSEMBLIES TO EXTEND FROM A TIEDOWN ANCHOR ON ONE SIDE OF THE CROP, OVER THE TOP OF THE PALLET UNITS, TO THE CORRESPONDING TIEDOWN ANCHOR ON THE OPPOSITE SIDE OF THE CROP.
13. INSTALL THE TWO FORWARD END RESTRAINT STRAPS AS DIRECTED IN KEY NUMBER ⑧.
14. INSTALL THE TWO AFT END RESTRAINT STRAPS AS DIRECTED IN KEY NUMBER ⑨.
15. NAIL THROUGH THE HOOK ATTACHMENT SLOT OF A HOLD-DOWN STRAP INTO EACH END OF THE SIDE BLOCKING ASSEMBLIES AND THE SIDE FILL PIECES W/1-10d PARTIALLY DRIVEN NAIL AND BEND OVER SIDE OF HOOK.

**GENERAL NOTES**

- A. THIS APPENDIX CANNOT STAND ALONE BUT MUST BE USED IN CONJUNCTION WITH THE BASIC LOADING PROCEDURES DRAWING 19-48-4905-CA17Q6. TO PRODUCE AN APPROVED LOAD, ALL PERTINENT PROCEDURES, SPECIFICATIONS AND CRITERIA SET FORTH WITHIN THE BASIC DRAWING WILL APPLY TO THE PROCEDURES DELINEATED IN THIS APPENDIX. ANY EXCEPTIONS TO THE BASIC PROCEDURES ARE SPECIFIED IN THIS APPENDIX.
- B. THE OUTLOADING PROCEDURES DEPICTED IN THIS DRAWING ARE APPLICABLE TO LOADS OF SCL #16B. SEE PAGE 4 FOR DETAILS OF THE PALLET UNITS. AN M3 (SUMMA) CROP IS SHOWN AS TYPICAL. OTHER MANUFACTURER'S CROPS CAN BE USED FOR THE LOAD SHOWN ON PAGE 2. THE SEQUENTIAL LOADING PROCEDURES DEPICTED AT LEFT DESCRIBE THE SEQUENCE USED TO LOAD AN M3 CROP. FOR AN M3A1 (HYUNDAI) CROP, SEQUENTIAL LOADING PROCEDURES 2 THROUGH 7 MUST BE REVERSED (THE END BLOCKING ASSEMBLY WITH HOLD DOWN BLOCKS MUST BE AT THE AFT OF AN M3A1 CROP). ACTUAL CROP CONFIGURATION WILL DETERMINE WHETHER THE SEQUENTIAL LOADING STARTS AT THE AFT OR THE FORWARD END OF THE CROP.
- C. THE LOADING PROCEDURES DEPICTED HEREIN MAY ALSO BE USED FOR OUTLOADING SIMILAR SCL LOADS WHEN IDENTIFIED BY DIFFERENT NATIONAL STOCK NUMBERS (NSN) THAN WHAT IS SHOWN ON PAGE 4, PROVIDED THE OVERALL UNIT DIMENSIONS DO NOT VARY FROM WHAT IS DELINEATED HEREIN.
- D. LIGHT PALLET UNITS MUST BE CONSTRUCTED IN ACCORDANCE WITH THE GUIDELINES DELINEATED IN THE BASIC UNITIZATION PROCEDURES DRAWING APPLICABLE TO THAT PALLET UNIT.
- E. DIMENSIONS, CUBE AND WEIGHT OF THE PALLET UNITS WILL VARY SLIGHTLY DEPENDING UPON THE ACTUAL DIMENSIONS OF THE BOXES AND THE WEIGHT OF THE SPECIFIC ITEM BEING UNITIZED.
- F. DIMENSIONS GIVEN FOR DUNNAGE ASSEMBLIES WILL BE FIELD CHECKED PRIOR TO THEIR ASSEMBLY. PALLET UNITS MUST FIT SNUGLY AGAINST THE DUNNAGE ASSEMBLIES. THIS GUIDANCE MUST BE APPLIED PRIOR TO BEGINNING AN OUTLOADING OPERATION. ALSO, DUE TO VARIATION OF PALLET UNIT DIMENSIONS, ADJUSTMENTS MAY BE REQUIRED AS TO THE LOCATION OF CERTAIN PIECES ON DUNNAGE ASSEMBLIES.
- G. ALL WEB STRAP TIEDOWN ASSEMBLIES MUST HAVE THE EXCESS LENGTH OF THE STRAP SECURED. ROLL UP AND BUNDLE THE EXCESS LENGTH OF WEB STRAP, SECURING WITH CABLE TIES. SEE THE "STRAP END SECUREMENT" DETAIL AND GENERAL NOTE "K.12" IN THE BASIC PROCEDURE DRAWING 19-48-4905-CA17Q6.
- H. EACH END OF THE SIDE BLOCKING ASSEMBLIES MUST BE SECURED BY NAILING A 10d NAIL THRU A 3" WEBSTRAP HOOK SLOT. SEE "STRAP HOOK DETAIL" AND GENERAL NOTE "G.2" IN THE BASIC PROCEDURES DRAWING 19-48-4905-CA17Q6.
- J. CONVERSION TO METRIC EQUIVALENTS: DIMENSIONS WITHIN THIS DOCUMENT ARE EXPRESSED IN INCHES, AND WEIGHTS ARE EXPRESSED IN POUNDS. WHEN NECESSARY, THE METRIC EQUIVALENTS MAY BE COMPUTED ON THE BASIS OF ONE INCH EQUALS 25.4MM AND ONE POUND EQUALS 0.454 KG.

BILL OF MATERIAL		
LUMBER	LINEAR FEET	BOARD FEET
1" X 4"	17	6
2" X 3" (ACTUAL)	2	1
2" X 4"	57	38
2" X 8"	39	52
4" X 4"	17	22
NAILS	NO. REQD	POUNDS
6d (2")	18	NIL
10d (3")	78	1-1/4
12d (3-1/4")	2	NIL
2" WEBSTRAP TIEDOWN ASSEMBLY	1 REQD	5.5 LBS

**LOAD AS SHOWN**

ITEM	QUANTITY	WEIGHT (APPROX)
A064 LIGHT PALLET UNIT	4	5,920 LBS
A131 LIGHT PALLET UNIT	4	5,208 LBS
B542 PALLET UNIT	8	18,576 LBS
DUNNAGE		246 LBS
CROP		3,800 LBS
TOTAL WEIGHT		33,750 LBS (APPROX)

## SCL #16B COMPOSITION CHART

DODIC	NSN	NOMENCLATURE	UNIT DWG	REQD	UNITS REQD	HC
A064	1305-01-156-7584	CARTRIDGE, 5.56MM M855/M856 BALL/TRACER 4 TO 1	4116/5A	76,800	4 LIGHT PLTS	1.4S
A131	1305-00-892-2150	CARTRIDGE, 7.62MM BALL M80 TRACER M62	4116/7	51,200	4 LIGHT PLTS	1.4S
B542	1310-01-159-8043	CARTRIDGE, 40MM M430	4116/26N	13,824	8 PALLETS	1.1E

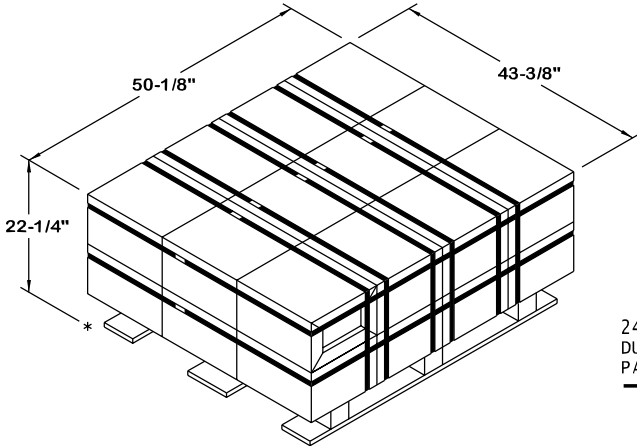

THE LIGHT A064 PALLET UNIT DEPICTED AT LEFT SHOULD BE CONSTRUCTED IAW THE AMC DRAWING LISTED ABOVE WITH THE FOLLOWING CHANGES:

1. ELIMINATE TWO LAYERS OF BOXES (24 BOXES).
2. ELIMINATE TWO HORIZONTAL STRAPS.
3. REDUCE THE TIEDOWN STRAP LENGTH TO 11'-1".

### LIGHT A064 PALLET UNIT DETAIL

24 BOXES OF 5.56MM CTG (800 PER BOX) AT 58 LBS - - - 1,392 LBS (APPROX)  
 DUNNAGE - - - - - 8 LBS  
 PALLET - - - - - 80 LBS

TOTAL WEIGHT - - - - - 1,480 LBS (APPROX)  
 CUBE - - - - - 28.0 CU FT (APPROX)

THE LIGHT A131 PALLET UNIT DEPICTED AT RIGHT SHOULD BE CONSTRUCTED IAW THE AMC DRAWING LISTED ABOVE WITH THE FOLLOWING CHANGES:

1. ELIMINATE THREE LAYERS OF BOXES (24 BOXES).
2. REDUCE THE LOAD STRAP LENGTH TO 11'-6".
3. REDUCE THE TIEDOWN STRAP LENGTH TO 9'-9".

### LIGHT A131 PALLET UNIT DETAIL

16 BOXES OF 7.62MM CTG (800 PER BOX) AT 77 LBS - - - 1,232 LBS (APPROX)  
 DUNNAGE - - - - - 5 LBS  
 PALLET - - - - - 65 LBS

TOTAL WEIGHT - - - - - 1,302 LBS (APPROX)  
 CUBE - - - - - 20.3 CU FT (APPROX)

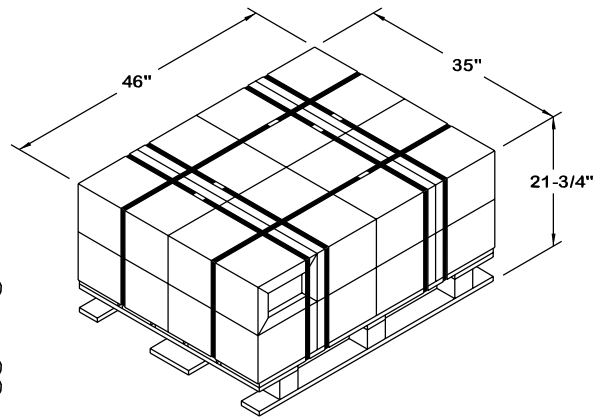

### B542 PALLET UNIT DETAIL

36 BOXES OF 40MM CTG (48 PER BOX) AT 60 LBS - - - - 2,160 LBS (APPROX)  
 DUNNAGE - - - - - 82 LBS  
 PALLET - - - - - 80 LBS

TOTAL WEIGHT - - - - - 2,322 LBS (APPROX)  
 CUBE - - - - - 57.1 CU FT (APPROX)

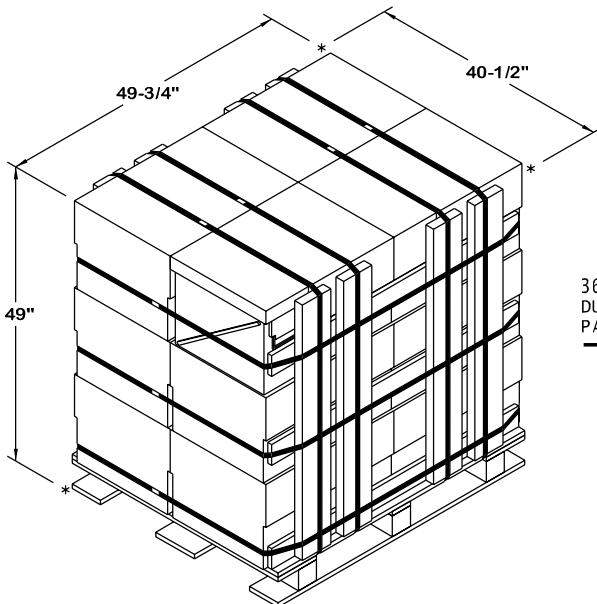

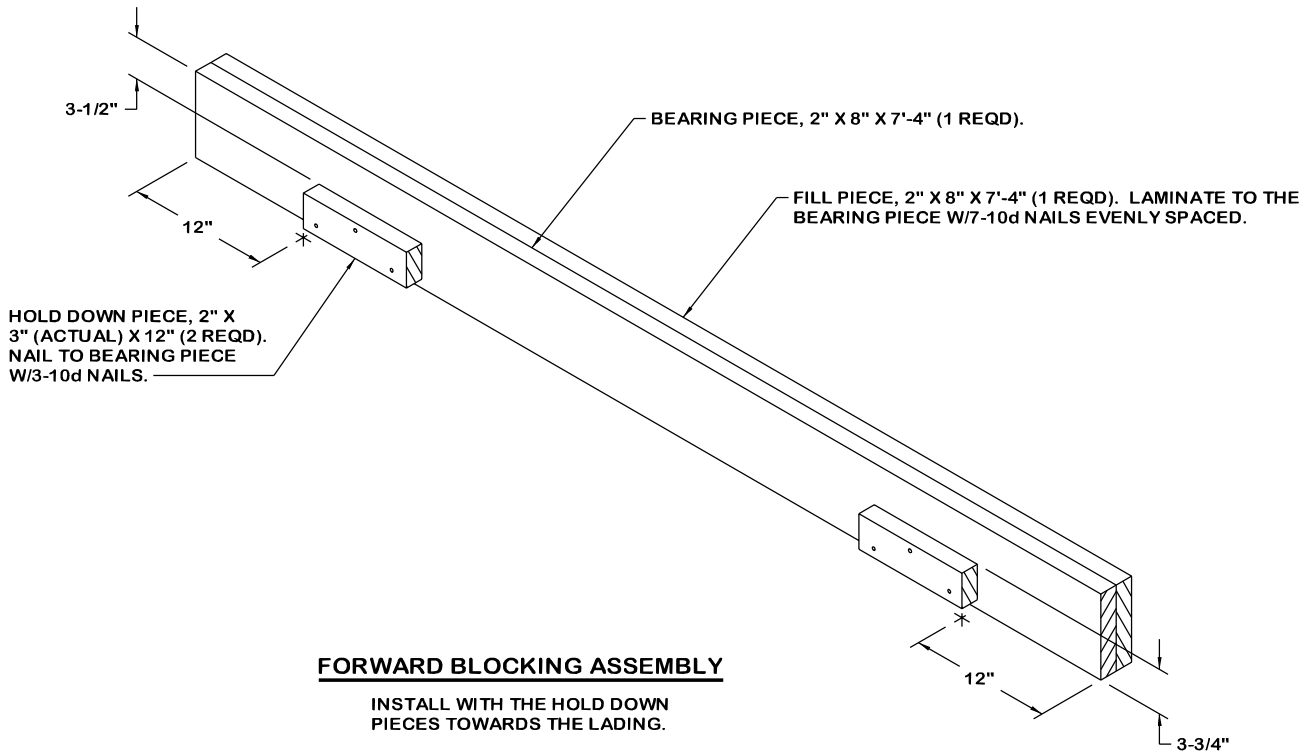

**FORWARD BLOCKING ASSEMBLY**

INSTALL WITH THE HOLD DOWN PIECES TOWARDS THE LADING.

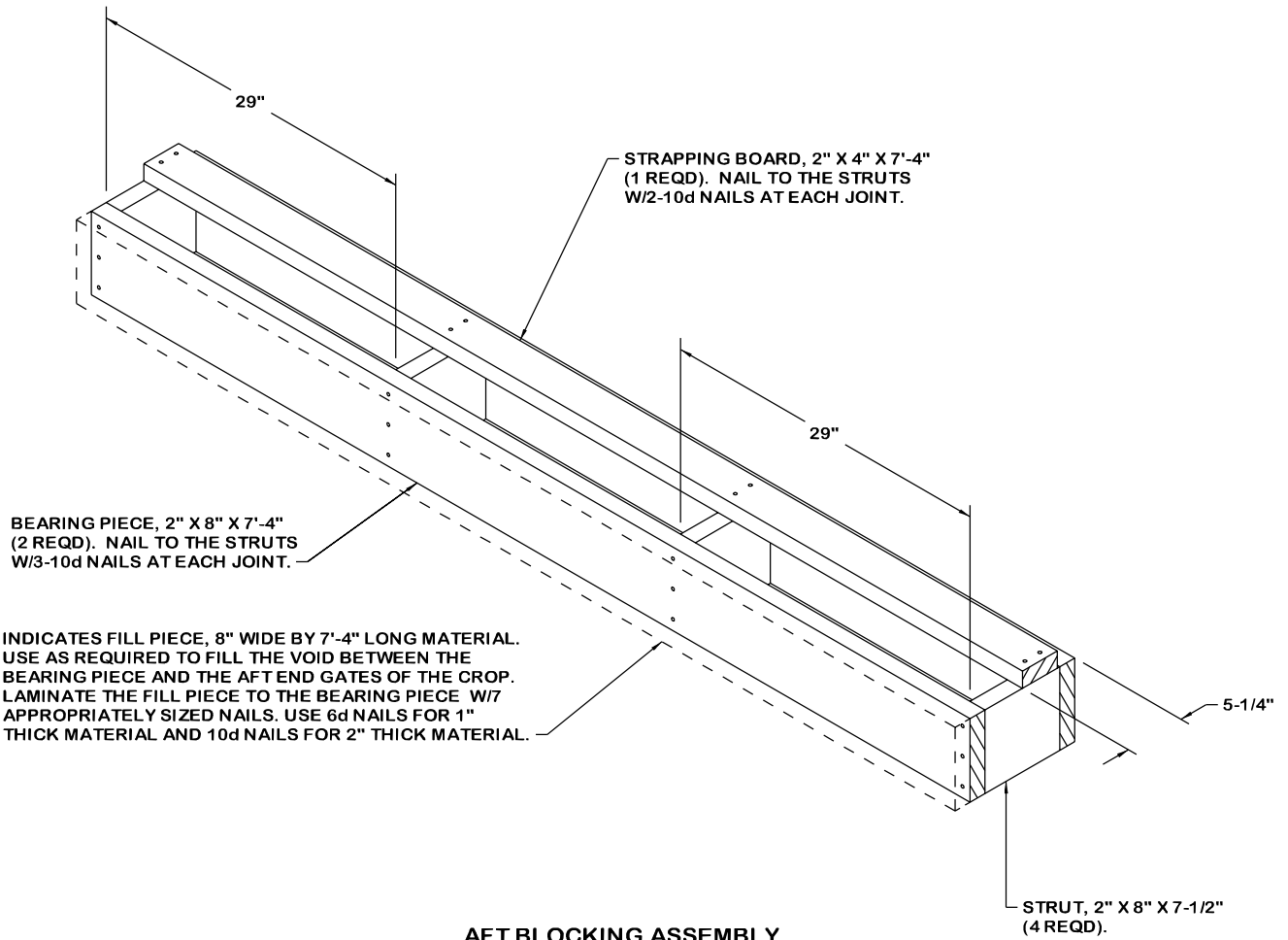

**AFT BLOCKING ASSEMBLY**

**DETAILS**

BEARING PIECE, 2" X 4" X 8'-3" (1 REQD).

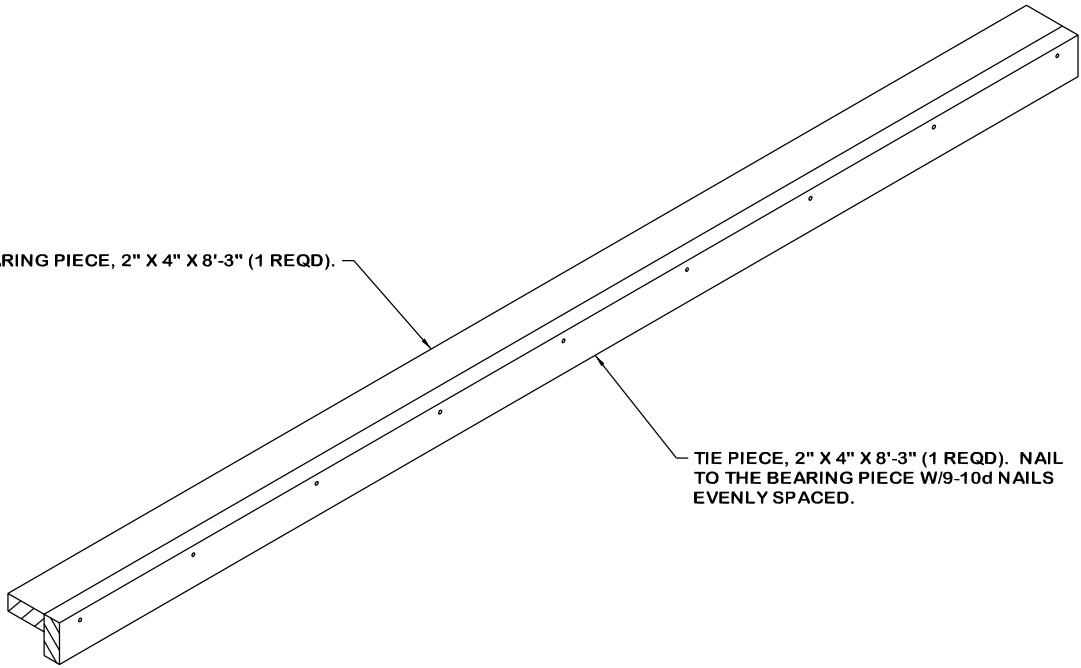

TIE PIECE, 2" X 4" X 8'-3" (1 REQD). NAIL TO THE BEARING PIECE W/9-10d NAILS EVENLY SPACED.

EDGE BOARD ASSEMBLY