

APPROVED BY  
BUREAU OF EXPLOSIVES

*David L. H.*

DATE 7-21-2007



# LOADING AND BRACING IN SIDE OPENING ISO CONTAINERS OF M117 750 POUND BOMBS PALLETIZED ON WOODEN PALLETS (4-PACK)

## INDEX

<u>ITEM</u>	<u>PAGE(S)</u>
TYPICAL LOADING PROCEDURES - - - - -	2
GENERAL NOTES AND MATERIAL SPECIFICATIONS - - - - -	3
PALLET UNIT DETAIL - - - - -	4
DETAILS - - - - -	4-7
LESS-THAN-FULL-LOAD DETAILS - - - - -	8

- LOADING AND BRACING SPECIFICATIONS SET FORTH WITHIN THIS DRAWING ARE APPLICABLE TO LOADS THAT ARE TO BE SHIPPED BY TRAILER/CONTAINER-ON-FLATCAR (T/COFC) RAIL CARRIER SERVICE. THESE SPECIFICATIONS MAY ALSO BE USED FOR LOADS THAT ARE TO BE MOVED BY MOTOR OR WATER CARRIERS.

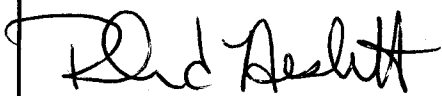
## U.S. ARMY MATERIEL COMMAND DRAWING

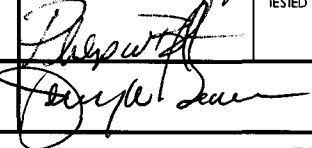
APPROVED, U.S. ARMY JOINT MUNITIONS COMMAND  	<b>CAUTION: VERIFY PRIOR TO USE AT WWW.DAC.ARMY.MIL THAT THIS IS THE MOST CURRENT VERSION OF THIS DOCUMENT. THIS IS PAGE 1 OF 8.</b>			
	<b>DO NOT SCALE</b>		<b>JULY 2007</b>	
	ENGINEER OR TECHNICIAN	BASIC REV.	<b>MELVIN SIX</b>	
APPROVED BY ORDER OF COMMANDING GENERAL, U.S. ARMY MATERIEL COMMAND  	TRANSPORTATION ENGINEERING DIVISION			
	VALIDATION ENGINEERING DIVISION	TESTED	CLASS	DIVISION
U.S. ARMY DEFENSE AMMUNITION CENTER	ENGINEERING DIRECTORATE		<b>19</b>	<b>48</b>
			<b>4354</b>	<b>15PB1015</b>

PROJECT CA 372-06

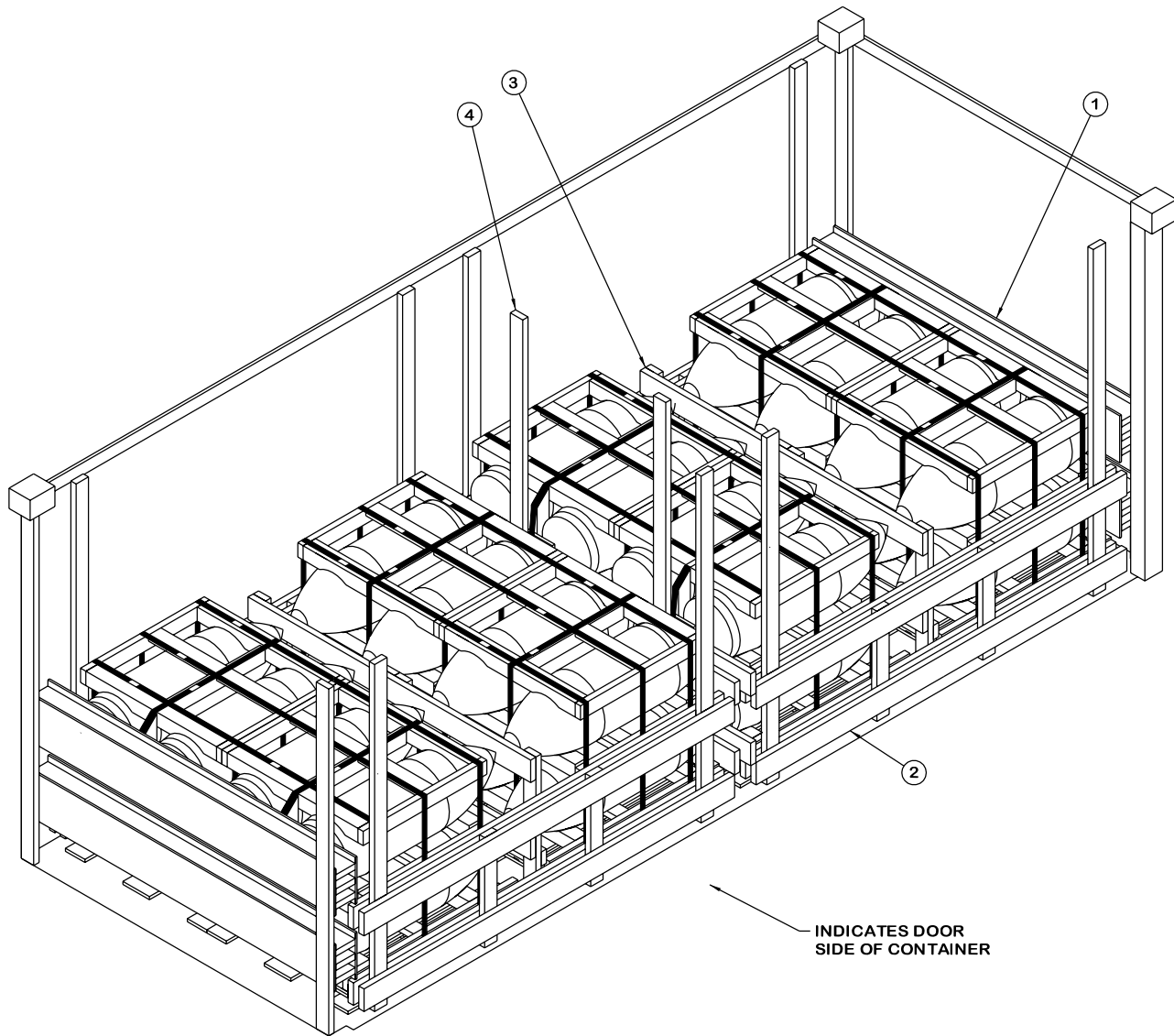

**ISOMETRIC VIEW**

**KEY NUMBERS**

- ① END BLOCKING ASSEMBLY (2 REQD). SEE THE DETAIL ON PAGE 6.
- ② SIDE FILL ASSEMBLY A (4 REQD). SEE THE DETAIL ON PAGE 7.
- ③ BUFFER ASSEMBLY (2 REQD). SEE THE DETAIL ON PAGE 5.
- ④ CENTER FILL ASSEMBLY (1 REQD). SEE THE DETAIL ON PAGE 5.

**BILL OF MATERIAL**

LUMBER	LINEAR FEET	BOARD FEET
2" X 4"	155	104
2" X 6"	281	281
NAILS	NO. REQD	POUNDS
6d (2")	216	1-1/2
10d (3")	322	5
PLYWOOD. 1/2"	56 SQ FT REQD	77 LBS

**LOAD AS SHOWN**

<u>ITEM</u>	<u>QUANTITY</u>	<u>WEIGHT (APPROX)</u>
PALLET UNIT - - - - -	8 - - - - -	25,840 LBS
DUNNAGE - - - - -	- - - - -	878 LBS
CONTAINER - - - - -	- - - - -	6,050 LBS
TOTAL WEIGHT - - - - -		32,768 LBS (APPROX)

(GENERAL NOTES CONTINUED)

L. MAXIMUM LOAD WEIGHT CRITERIA:

THE MAXIMUM LOAD WEIGHTS ARE CONTROLLED BY EQUIPMENT CAPABILITY FACTORS. ALTHOUGH THE HEAVIEST MAXIMUM LOADS ARE DELINEATED IN THE LOAD VIEWS, PROVISIONS ARE INCLUDED WITHIN THIS DRAWING SO THAT THE BASIC LOADS CAN BE ADJUSTED TO SATISFY A LESSER QUANTITY OF LADING UNITS. DEPENDING ON TRANSPORTATION ROUTING, IT MAY BE NECESSARY TO REDUCE THE LOAD WEIGHT TO SATISFY "WEIGHT LAWS" OF CERTAIN STATES. ALSO, IT MAY BE NECESSARY TO REDUCE THE LOAD WEIGHT TO SATISFY OTHER WEIGHT RESTRICTIONS IMPOSED ON THE INTERMODAL CONTAINER SYSTEM.

M. REQUIREMENTS CITED WITHIN THE ASSOCIATION OF AMERICAN RAILROADS (AAR) INTERMODAL LOADING GUIDE APPLY WHEN THE SHIPMENT MOVES BY TRAILER/CONTAINER-ON-FLATCAR (T/COFC). SPECIAL T/COFC NOTES FOLLOW:

1. A LOADED CONTAINER MUST BE ON A CHASSIS EQUIPPED WITH TWO BOGIE ASSEMBLIES WHEN BEING MOVED IN TOFC SERVICE.
2. THE LOAD LIMIT OF A T/COFC RAILCAR MUST NOT BE EXCEEDED, NOR WILL A CAR BE LOADED SO THAT THE TRUCK UNDER ONE END OF THE CAR CARRIES MORE THAN ONE-HALF OF THE LOAD LIMIT FOR THAT CAR.

N. DURING INTRASTATE AND/OR INTERSTATE MOVES BY MOTOR CARRIER, A PROPER CHASSIS OR MODIFIED FLATBED TRAILER MUST BE USED TO PRECLUDE VIOLATION OF ONE OR MORE "WEIGHT LAWS" APPLICABLE TO THE STATE OR STATES INVOLVED.

O. WHETHER A CONTAINER IS FULL OR IS LOADED WITH A REDUCED QUANTITY OF LADING UNITS, THE LENGTHWISE CENTER OF GRAVITY OF THE LOAD MUST BE WITHIN 12", IN EITHER DIRECTION, OF THE MID-POINT OF THE CONTAINER.

P. THE QUANTITY OF PALLET UNITS SHOWN IN THE LOAD ON PAGE 2 MAY BE REDUCED FOR SHIPMENT, IF DESIRED. SEE THE "LESS-THAN-FULL-LOAD" DETAIL ON PAGE 8.

Q. RECOMMENDED SEQUENTIAL LOADING PROCEDURES:

1. PREFABRICATE TWO END BLOCKING ASSEMBLIES, TWO BUFFER ASSEMBLIES, AND FOUR SIDE FILL ASSEMBLIES.
2. INSTALL TWO SIDE FILL ASSEMBLIES ON THE FAR WALL.
3. INSTALL TWO END BLOCKING ASSEMBLIES.
4. LOAD TWO PALLET UNITS AT EACH END OF THE CONTAINER WITH THE AFT END OF THE PALLET UNITS TOWARD THE END BLOCKING ASSEMBLY.
5. INSTALL ONE BUFFER ASSEMBLY IN FRONT OF EACH PAIR OF PALLET UNITS.
6. LOAD TWO PALLET UNITS WITH THE FORWARD END OF THE PALLET UNITS TOWARD THE BUFFER ASSEMBLY.
7. INSTALL THE CENTER FILL ASSEMBLY.
8. INSTALL TWO SIDE FILL ASSEMBLIES.

**MATERIAL SPECIFICATIONS**

- LUMBER - - - - : SEE TM 743-200-1 (DUNNAGE LUMBER) AND VOLUNTARY PRODUCT STANDARD PS 20.
- NAILS - - - - : ASTM F1667; COMMON STEEL NAIL (NLCMS OR NLCMMS).
- PLYWOOD - - - - : COMMERCIAL ITEM DESCRIPTION A-A-55057, INDUSTRIAL PLYWOOD, INTERIOR WITH EXTERIOR GLUE, GRADE C-D. IF SPECIFIED BETTER INTERIOR OR AN EXTERIOR GRADE MAY BE SUBSTITUTED.
- WIRE,  
CARBON STEEL - - : ASTM A853; ANNEALED AT FINISH, BLACK OXIDE FINISH, 0.0800" DIA, GRADE 1006 OR BETTER.

**GENERAL NOTES**

- A. THIS DOCUMENT HAS BEEN PREPARED AND ISSUED IN ACCORDANCE WITH AR 740-1 AND AUGMENTS TM 743-200-1 (CHAPTER 5).
- B. THE SPECIFIED OUTLOADING PROCEDURES ARE APPLICABLE TO LOADS OF 750 POUND BOMBS PACKED ON A WOODEN PALLET UNIT. SUBSEQUENT REFERENCE TO PALLET UNIT HEREIN MEANS THE PALLET UNIT WITH AMMUNITION ITEMS. SEE PAGE 4 AND DEPARTMENT OF THE NAVY DRAWING WR-53/705 FOR DETAILS OF THE PALLET UNIT. **CAUTION:** REGARDLESS OF THE QUANTITY OF PALLET UNITS TO BE SHIPPED, THE "MAXIMUM GROSS WEIGHT" OF THE SIDE OPENING ISO CONTAINER MUST NOT BE EXCEEDED.
- C. THE LOADS AS SHOWN ARE BASED ON A 6,050 POUND 20' LONG BY 8' WIDE BY 8'-6" HIGH SIDE OPENING ISO CONTAINER WITH INSIDE DIMENSIONS OF 19'-5-1/4" LONG BY 89-3/4" WIDE BY 88" AND A MAXIMUM GROSS WEIGHT OF 52,910 POUNDS. THE LOAD IS DESIGNED FOR TRAILER/CONTAINER-ON-FLATCAR (T/COFC) SHIPMENT, HOWEVER, THE LOAD AS DESIGNED CAN ALSO BE MOVED BY MOTOR OR WATER CARRIERS. **NOTICE:** OTHER CONTAINERS OF THE SAME DESIGN CONFIGURATION CAN ALSO BE USED.
- D. WHEN LOADING THE UNITS, THEY ARE TO BE POSITIONED SO AS TO ACHIEVE A TIGHT LOAD (TIGHT AGAINST THE DUNNAGE ASSEMBLIES). THE UNBLOCKED SPACE ACROSS THE WIDTH OF A LOAD BAY IS NOT TO EXCEED 1-1/2". EXCESSIVE SLACK CAN BE ELIMINATED FROM A LOAD BY LAMINATING ADDITIONAL PIECES OF APPROPRIATE THICKNESS TO THE SIDE FILL ASSEMBLIES. NAIL EACH ADDITIONAL PIECE TO THE BUFFER PIECE W/1 APPROPRIATELY SIZED NAIL EVERY 12". ADDITIONALLY, THE THICKNESS OF THE DUNNAGE LUMBER USED IN THE SIDE FILL ASSEMBLIES MAY BE ADJUSTED AS REQUIRED TO FACILITATE VARIANCE IN THE SIZE OF THE CONTAINER.
- E. DUNNAGE LUMBER SPECIFIED IS OF NOMINAL SIZE. FOR EXAMPLE, 1" X 6" MATERIAL IS ACTUALLY 3/4" THICK BY 5-1/2" WIDE AND 2" X 6" MATERIAL IS ACTUALLY 1-1/2" THICK BY 5-1/2" WIDE.
- F. A STAGGERED NAILING PATTERN WILL BE USED WHENEVER POSSIBLE WHEN NAILS ARE DRIVEN INTO JOINTS OF DUNNAGE ASSEMBLIES OR WHEN LAMINATING DUNNAGE. ADDITIONALLY, THE NAILING PATTERN FOR AN UPPER PIECE OF LAMINATED DUNNAGE WILL BE ADJUSTED AS REQUIRED SO THAT A NAIL FOR THAT PIECE WILL NOT BE DRIVEN THROUGH ONTO OR RIGHT BESIDE A NAIL IN A LOWER PIECE.
- G. IN SOME CONTAINERS THERE IS A SLOT AT THE CORNERS OF THE ENDWALLS. PIECES OF DUNNAGE MATERIAL MUST BE LAMINATED TO THE BUFFER PIECES ON THE END BLOCKING ASSEMBLIES, STRUT ASSEMBLIES, AND THE LEDGER ASSEMBLIES TO PROVIDE A FLAT SURFACE FOR THE BUFFER PIECES. A PIECE OF 2" X 4", 2" X 3" OR A SPECIAL WIDTH PIECE CUT-TO-FIT CAN BE USED. THIS FILL PIECE WILL BE NAILED WITH ONE APPROPRIATELY SIZED NAIL EVERY 12". NOTE THAT SOME CONTAINERS ARE EQUIPPED WITH "TIE-BARS" IN THE CORNER SLOT, WHICH PRECLUDE THE USE OF A FULL HEIGHT FILL PIECE. WHEN "TIE-BARS" ARE PRESENT, THE FILL PIECE MUST BE INSTALLED IN SEGMENTS DESIGNED TO FIT BETWEEN THE "TIE-BARS" VERTICALLY. THE FILL PIECE(S) IS NOT REQUIRED WHEN THE CORNER PORTIONS OF THE CONTAINER ENDWALLS ARE SMOOTH AND FLAT. DO NOT ALLOW ANY DUNNAGE ASSEMBLY TO CONTACT THE CONTAINER ENDWALLS, ONLY THE CORNER POSTS OF THE CONTAINER SHOULD BE USED FOR LONGITUDINAL BLOCKING.
- H. **CAUTION:** DO NOT NAIL DUNNAGE MATERIAL TO THE CONTAINER WALLS OR FLOOR. ALL NAILING WILL BE WITHIN THE DUNNAGE.
- J. PORTIONS OF THE CONTAINER DEPICTED WITHIN THIS DRAWING, SUCH AS THE SIDE DOORS, HAVE NOT BEEN SHOWN IN THE LOAD VIEW FOR CLARITY PURPOSES.
- K. CONVERSION TO METRIC EQUIVALENTS: DIMENSIONS WITHIN THIS DOCUMENT ARE EXPRESSED IN INCHES AND WEIGHTS ARE EXPRESSED IN POUNDS. WHEN NECESSARY, THE METRIC EQUIVALENTS MAY BE COMPUTED ON THE BASIS OF ONE INCH EQUALS 25.4MM AND ONE POUND EQUALS 0.454 KG.

(CONTINUED AT LEFT)

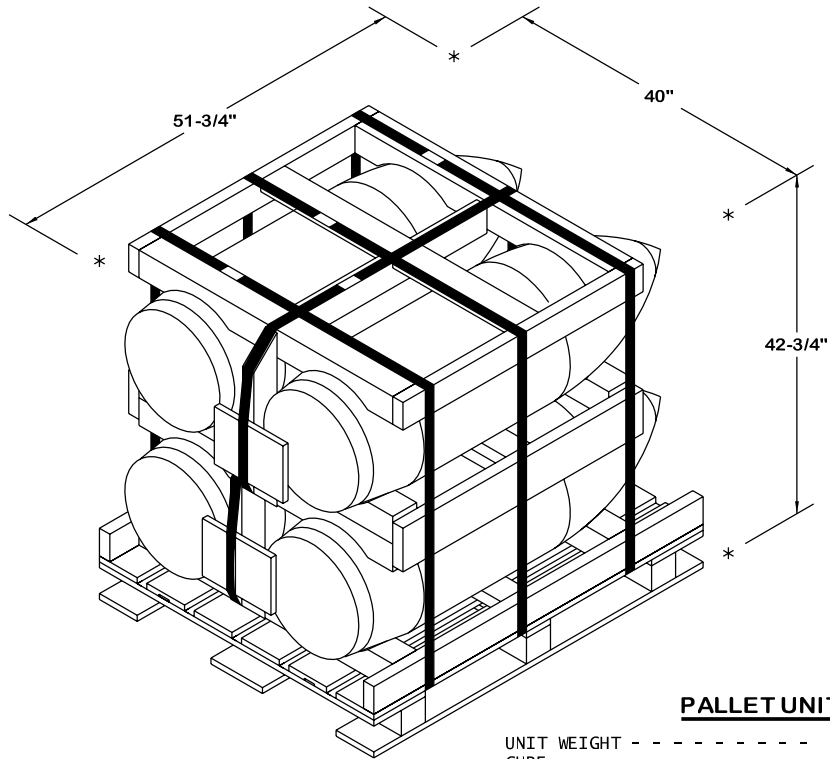

**PALLET UNIT**

UNIT WEIGHT - - - - - 3,230 LBS (APPROX)  
 CUBE - - - - - 51.2 CU FT

BUFFER PIECE, 2" X 6" X 44" (2 REQD). NAIL TO THE LONGITUDINAL PIECE W/3-10d NAILS AT EACH JOINT. **NOTE:** THE BUFFER PIECE WITH THE 18" DIMENSION IS TO BE LOCATED NEXT TO THE BOMB NOSE ON THE LATERALLY ADJACENT PALLET UNIT.

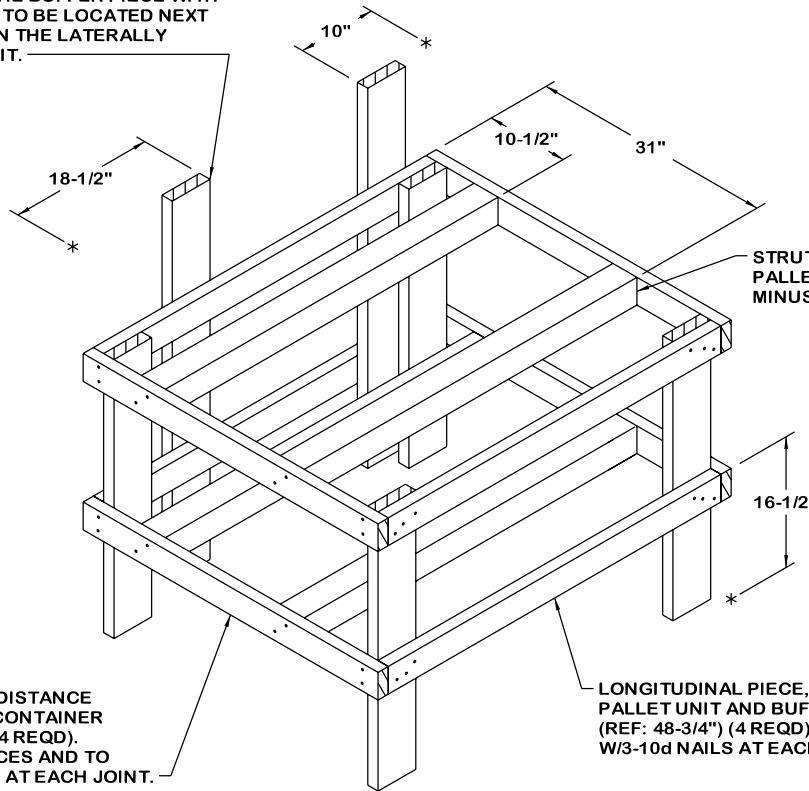

STRUT, 4" X 4" BY CUT-TO-FIT BETWEEN PALLET UNIT AND BUFFER ASSEMBLY MINUS 3" (REF: 48-3/4") (4 REQD).

LATERAL PIECE, 2" X 4" BY DISTANCE FROM ADJACENT UNIT TO CONTAINER DOOR MINUS 2" (REF: 43") (4 REQD). NAIL TO THE VERTICAL PIECES AND TO THE STRUTS W/2-10d NAILS AT EACH JOINT.

LONGITUDINAL PIECE, 2" X 4" BY CUT-TO-FIT BETWEEN PALLET UNIT AND BUFFER ASSEMBLY MINUS 3" (REF: 48-3/4") (4 REQD). NAIL TO THE VERTICAL PIECES W/3-10d NAILS AT EACH END.

**OMITTED UNIT ASSEMBLY**

A RIGHT HAND ASSEMBLY IS SHOWN, A LEFT HAND ASSEMBLY MAY ALSO BE CONSTRUCTED. THIS ASSEMBLY IS FOR USE IN PLACE OF AN OMITTED PALLET UNIT. NO MORE THAN TWO OMITTED UNIT ASSEMBLIES MAY BE USED PER LOAD. DO NOT INSTALL AN OMITTED UNIT ASSEMBLY IMMEDIATELY ADJACENT TO ANOTHER OMITTED UNIT ASSEMBLY.

BUFFER PIECE, 2" X 6" X 6'-7"  
(2 REQD). NAIL TO THE  
VERTICAL PIECES W/3-10d  
NAILS AT EACH JOINT.

VERTICAL PIECE, 2" X 4"  
X 36-1/2" (4 REQD).

HOLD DOWN PIECE, 2"  
X 4" X 6'-7" (1 REQD).  
NAIL TO THE VERTICAL  
PIECE W/2-10d NAILS  
AT EACH JOINT.

VERTICAL PIECE, 2" X 4" BY  
INSIDE CONTAINER HEIGHT  
MINUS 1" (REF: 7'-3") (2 REQD).

BUFFER PIECE, 2" X 6" BY INSIDE  
CONTAINER WIDTH MINUS 1"  
(REF: 7'-4") (4 REQD). NAIL TO  
THE VERTICAL PIECES AND  
FILL PIECES W/3-10d NAILS  
AT EACH JOINT.

FILL PIECE, (AS NEEDED), 1"  
X 4" OR 2" X 4" X 30-1/2" (2  
REQD). LAMINATE TO THE  
VERTICAL PIECE W/4 APPRO-  
PRIATE SIZED NAILS.

**BUFFER ASSEMBLY**

NOTE: IF A OMITTED UNIT ASSEMBLY IS  
USED, THE BUFFER PIECE SHOULD BE  
LOCATED AGAINST THE OMITTED UNIT  
ASSEMBLY LATERAL PIECE.

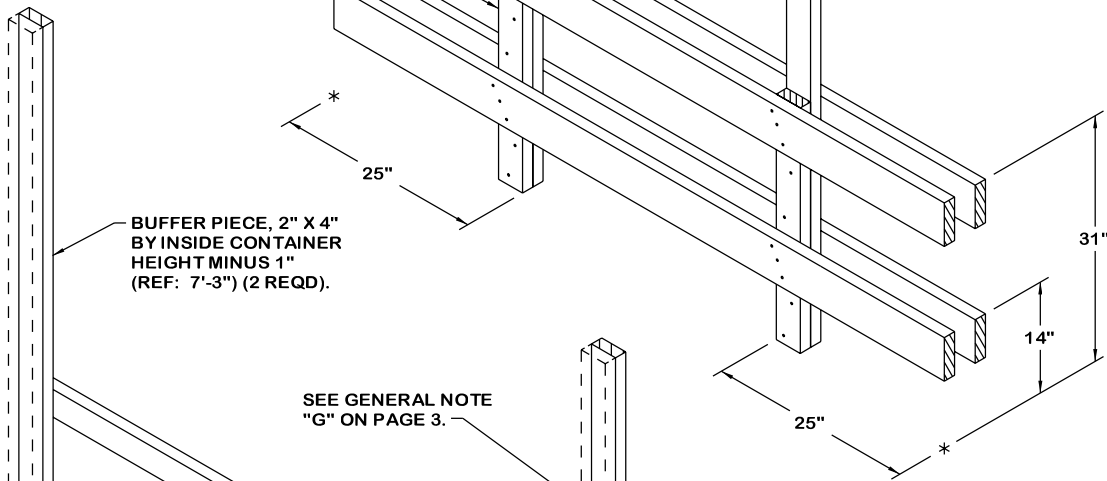

**CENTER FILL ASSEMBLY**

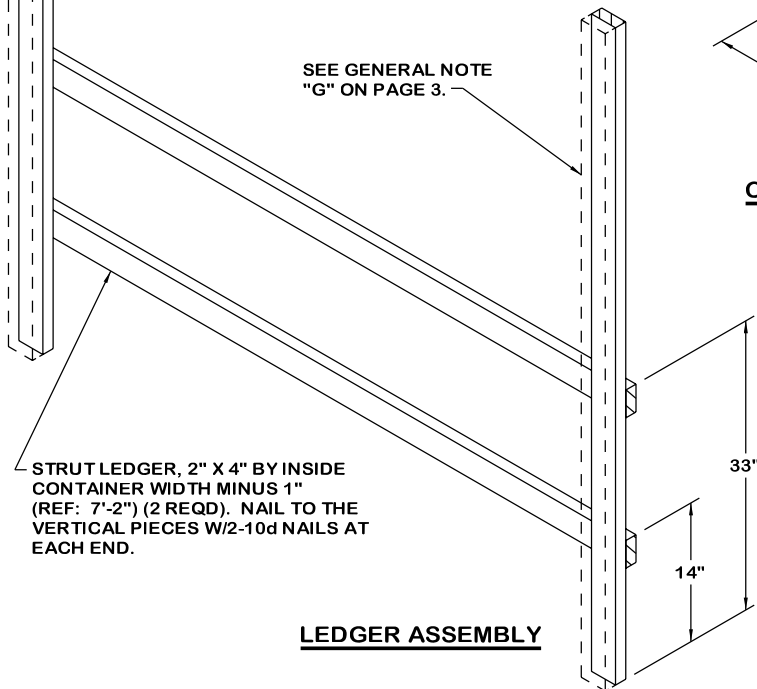

**LEDGER ASSEMBLY**

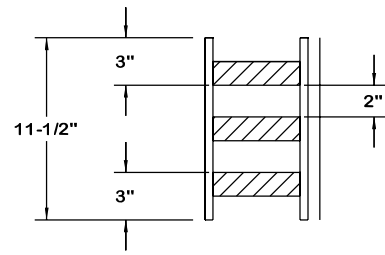
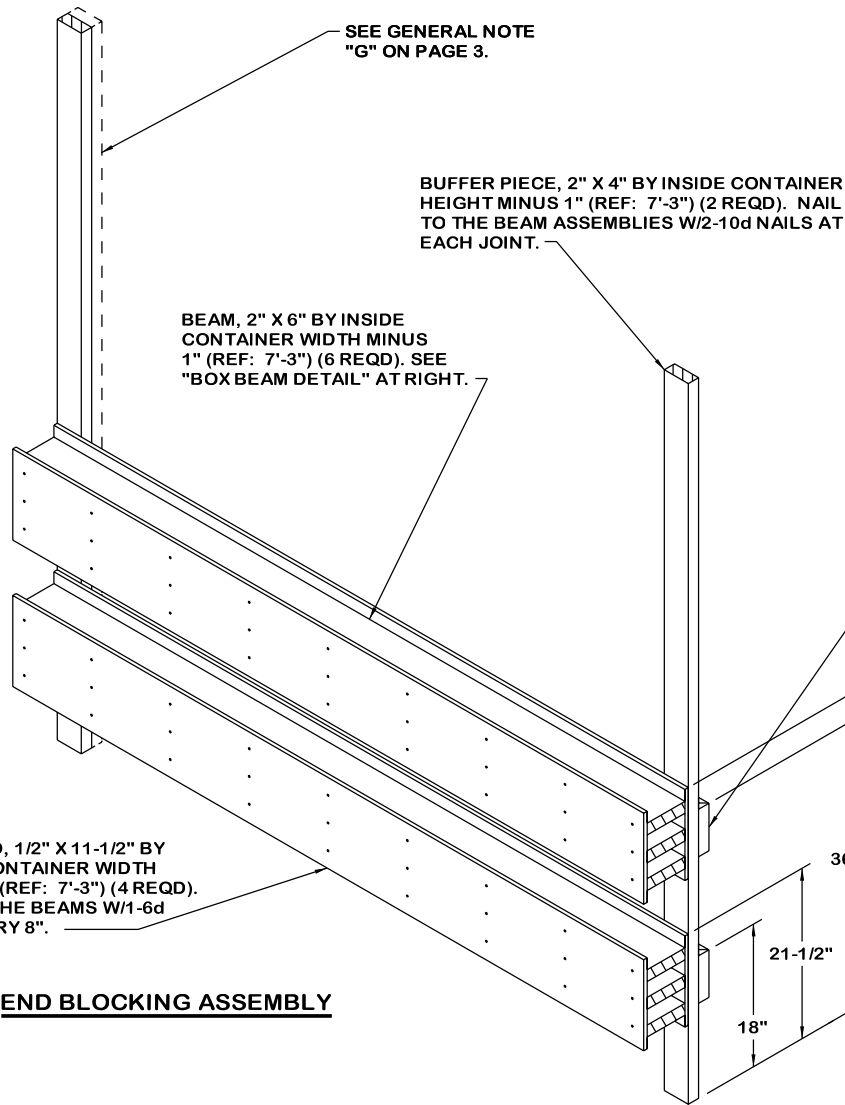

**BOX BEAM DETAIL**

STRUT LEDGER, 2" X 4" X 6" (4 REQD IF STRUTS ARE REQUIRED AS SHOWN ON PAGE 8). NAIL TO THE BUFFER PIECE W/2-10d NAILS.

**END BLOCKING ASSEMBLY**

BUFFER PIECE, 2" X 4" BY INSIDE CONTAINER HEIGHT MINUS 1" (REF: 7'-3") (2 REQD). NAIL TO THE STRUTS W/2-12d NAILS AT EACH JOINT.

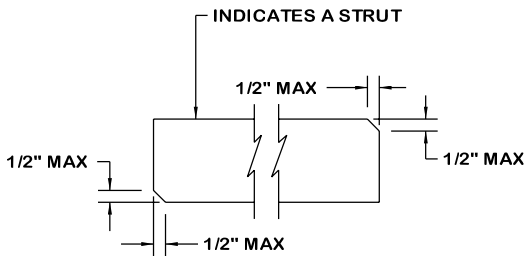

**BEVEL-CUT**

BEVEL CUTTING THE STRUT AS SPECIFIED WILL FACILITATE INSTALLING THE STRUTS WITH A "DRIVE FIT". CAUTION: DO NOT BEVEL A CORNER MORE THAN 1/2".

STRUT, 4" X 4" X 26" (2 REQD).

VERTICAL PIECE, 2" X 4" X 38" (1 REQD). NAIL TO STRUTS W/2-12d NAILS AT EACH JOINT.

**STRUT ASSEMBLY**

VERTICAL PIECE, 2" X 4" BY INSIDE CONTAINER HEIGHT MINUS 1" (REF: 7'-3" ON FAR SIDE OF CONTAINER AND 6'-11" ON DOOR SIDE OF CONTAINER) (2 REQD).

BUFFER PIECE, 2" X 4" X 8'-8" (4 REQD).  
NAIL TO THE VERTICAL PIECES  
W/3-10d NAILS AT EACH JOINT.

VERTICAL PIECE, 2" X 4" BY INSIDE CONTAINER HEIGHT MINUS 1" (REF: 7'-3" ON FAR SIDE OF CONTAINER AND 6'-11" ON DOOR SIDE OF CONTAINER) (1 REQD).

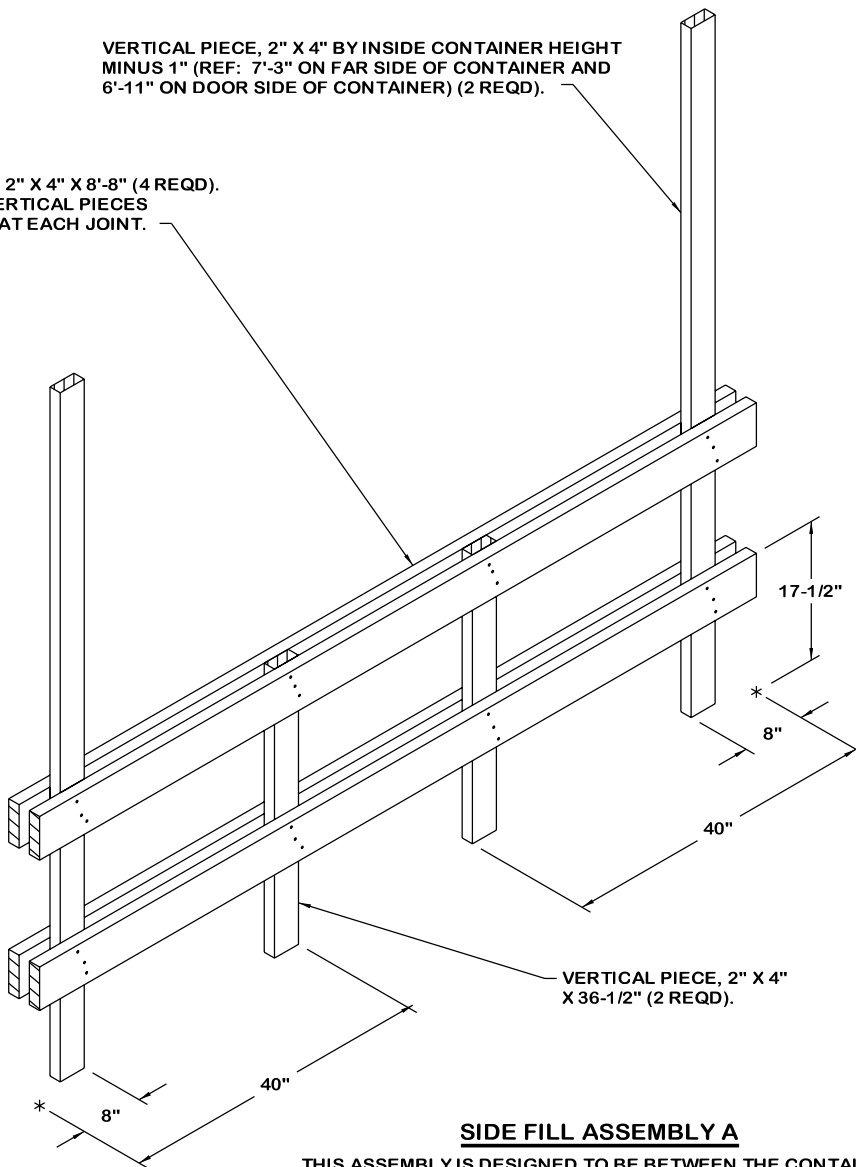

VERTICAL PIECE, 2" X 4" X 36-1/2" (2 REQD).

**SIDE FILL ASSEMBLY A**

THIS ASSEMBLY IS DESIGNED TO BE BETWEEN THE CONTAINER WALL AND TWO PALLET UNITS. NOTE: THE BUFFER PIECES MAY BE REPLACED WITH 1" X 6" MATERIAL OR THE BUFFER PIECES FITTING AGAINST THE CONTAINER MAY BE OMITTED TO REDUCE THE THICKNESS OF THE SIDE BLOCKING ASSEMBLY.

BUFFER PIECE, 2" X 4" X 51" (4 REQD).  
NAIL TO THE VERTICAL PIECES  
W/3-10d NAILS AT EACH JOINT.

VERTICAL PIECE, 2" X 4" X 36-1/2" (1 REQD).

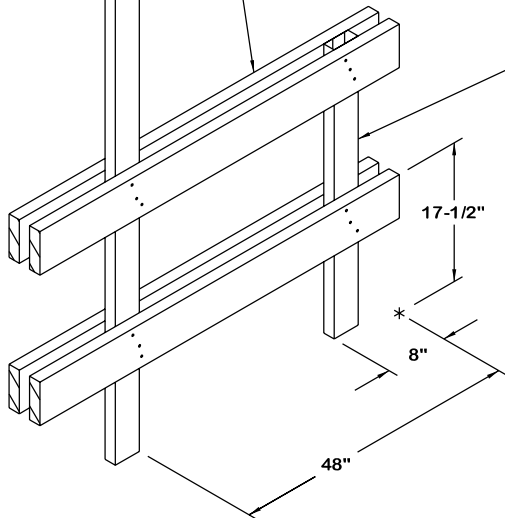

**SIDE FILL ASSEMBLY B**

THIS ASSEMBLY IS DESIGNED TO BE BETWEEN THE CONTAINER WALL AND ONE PALLET UNIT. NOTE: THE BUFFER PIECES MAY BE REPLACED WITH 1" X 6" MATERIAL OR THE BUFFER PIECES FITTING AGAINST THE CONTAINER MAY BE OMITTED TO REDUCE THE THICKNESS OF THE SIDE BLOCKING ASSEMBLY.

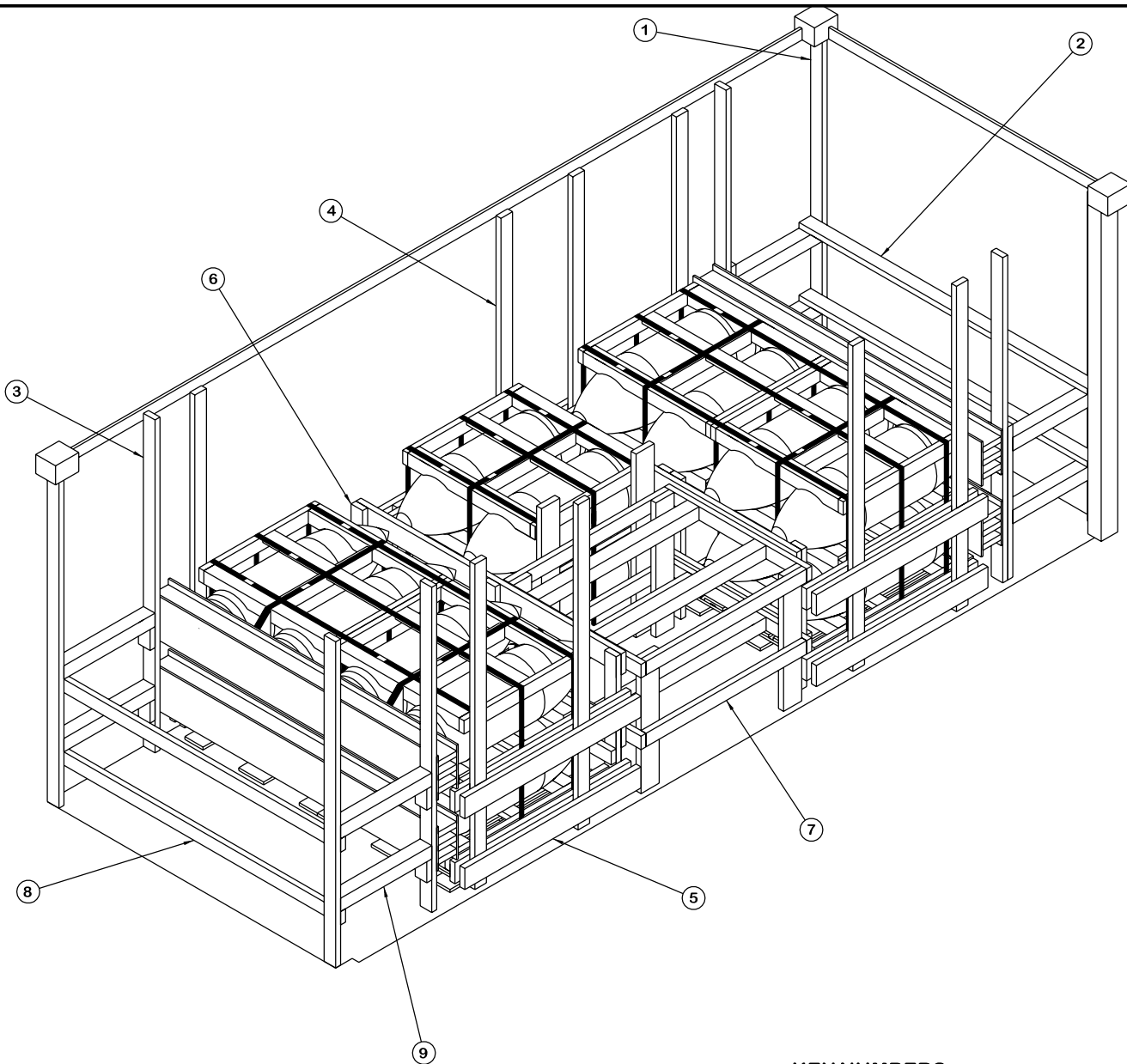

**LESS-THAN-FULL-LOAD PROCEDURE**

SEE GENERAL NOTE "0" ON PAGE 3.

**KEY NUMBERS**

- ① STRUT ASSEMBLY (2 REQD). SEE THE DETAIL ON PAGE 6. AFTER THE END BLOCKING ASSEMBLY IS INSTALLED, NAIL THROUGH THE BUFFER PIECE OF THE STRUT ASSEMBLY INTO THE VERTICAL PIECE OF THE END BLOCKING ASSEMBLY W/3-10d NAILS.
- ② SPREADER PIECE, 2" X 4" BY INSIDE CONTAINER WIDTH MINUS 1" (REF: 7'-4") (2 REQD). NAIL TO THE STRUTS OF STRUT ASSEMBLY W/2-10d NAILS AT EACH END.
- ③ END BLOCKING ASSEMBLY (2 REQD). SEE THE DETAIL ON PAGE 6.
- ④ SIDE BLOCKING ASSEMBLY A (1 REQD). SEE THE DETAIL ON PAGE 7.
- ⑤ SIDE BLOCKING ASSEMBLY B (3 REQD). SEE THE DETAIL ON PAGE 7.
- ⑥ BUFFER ASSEMBLY (2 REQD). SEE THE DETAIL ON PAGE 5.
- ⑦ OMITTED UNIT ASSEMBLY (1 SHOWN). SEE DETAIL ON PAGE 4. NAIL LATERAL PIECE OF THE OMITTED UNIT ASSEMBLY TO THE BUFFER PIECE OF THE BUFFER ASSEMBLY W/4-10d NAILS OR WIRE TIE THE OMITTED UNIT ASSEMBLY TO THE BUFFER ASSEMBLY WITH TWO .0800" DIA BY 24" WIRES.
- ⑧ LEDGER ASSEMBLY, (1 REQD). SEE DETAIL ON PAGE 5.
- ⑨ STRUT, 4" X 4" BY CUT-TO-FIT (REF: 24-1/2") (4 REQD). TOENAIL TO THE BUFFER PIECES OF THE END BLOCKING ASSEMBLY AND TO THE LEDGER ASSEMBLY W/2-12d NAILS AT EACH END. SEE THE "BEVEL-CUT" DETAIL ON PAGE 6.