

LOADING AND BRACING* IN MILVAN CONTAINERS[⊗] OF CARTRIDGE, 105MM, PACKED IN PA71 FIBER CONTAINERS IN WIREBOUND PALLET BOX

INDEX

ITEM	PAGE(S)
TYPICAL LOADING PROCEDURES - - - - -	2
GENERAL NOTES AND MATERIAL SPECIFICATIONS - - - - -	3
WI REBOUND PALLET BOX DETAILS - - - - -	4
DETAILS - - - - -	4-5
LESS-THAN-FULL-LOAD PROCEDURE - - - - -	6

*THE PROCEDURES SHOWN HEREIN ARE APPLICABLE TO LOADS THAT ARE TO BE SHIPPED BY CONTAINER-ON-FLATCAR (COFC) RAIL, MOTOR, OR WATER CARRIERS.

⊗ONLY MILVAN CONTAINERS WHICH HAVE BEEN MODIFIED TO INCLUDE A MECHANICAL LOAD BRACING SYSTEM THAT SATISFIES THE REQUIREMENTS OF THE BUREAU OF EXPLOSIVES PAMPHLET 6C WILL BE USED FOR THE MOVEMENT OF AMMUNITION BY T/COFC SERVICE.

DISTRIBUTION STATEMENT A:

APPROVED FOR PUBLIC RELEASE
DISTRIBUTION IS UNLIMITED.

U.S. ARMY MATERIEL COMMAND DRAWING

APPROVED, U.S. ARMY JOINT MUNITIONS COMMAND RUS.ALLEN.J Digitally signed by .1230354282 RUS.ALLEN.J.1230354282 Date: 2018.03.27 15:15:51 -05'00'		CAUTION: VERIFY PRIOR TO USE AT HTTPS://MHP.REDSTONE.ARMY.MIL THAT THIS IS THE MOST CURRENT VERSION OF THIS DOCUMENT. THIS IS PAGE 1 OF 6.			
		DO NOT SCALE		MARCH 2018	
		DESIGN ENGINEER	BASIC	MADELINE BANKS	
			REV.		
APPROVED BY ORDER OF COMMANDING GENERAL, U.S. ARMY MATERIEL COMMAND SHIMP.UPTON Digitally signed by .R.1231257183 SHIMP.UPTON.R.1231257183 Date: 2018.03.28 08:40:26 -05'00'		ENGINEERING DIVISON	FIEFFER.LAUR A.A.1230375727	<small>Digitally signed by FIEFFER.LAURA.A.1230375727 Date: 2018.03.08 15:13:48 -05'00'</small>	
		TEST ENGINEER	FELICIANO.AD IN.1259200373	CLASS	DIVISION
		TEST REPORT	N/A	DRAWING	FILE
U.S. ARMY DEFENSE AMMUNITION CENTER		EXPLOSIVE SAFETY DIRECTORATE	THOMAS.CARL.AN THONY.1104621372	19	48
			<small>Digitally signed by THOMAS.CARL.ANTHONY.1104621372 Date: 2018.03.14 14:31:48 -05'00'</small>	4348	15P1002

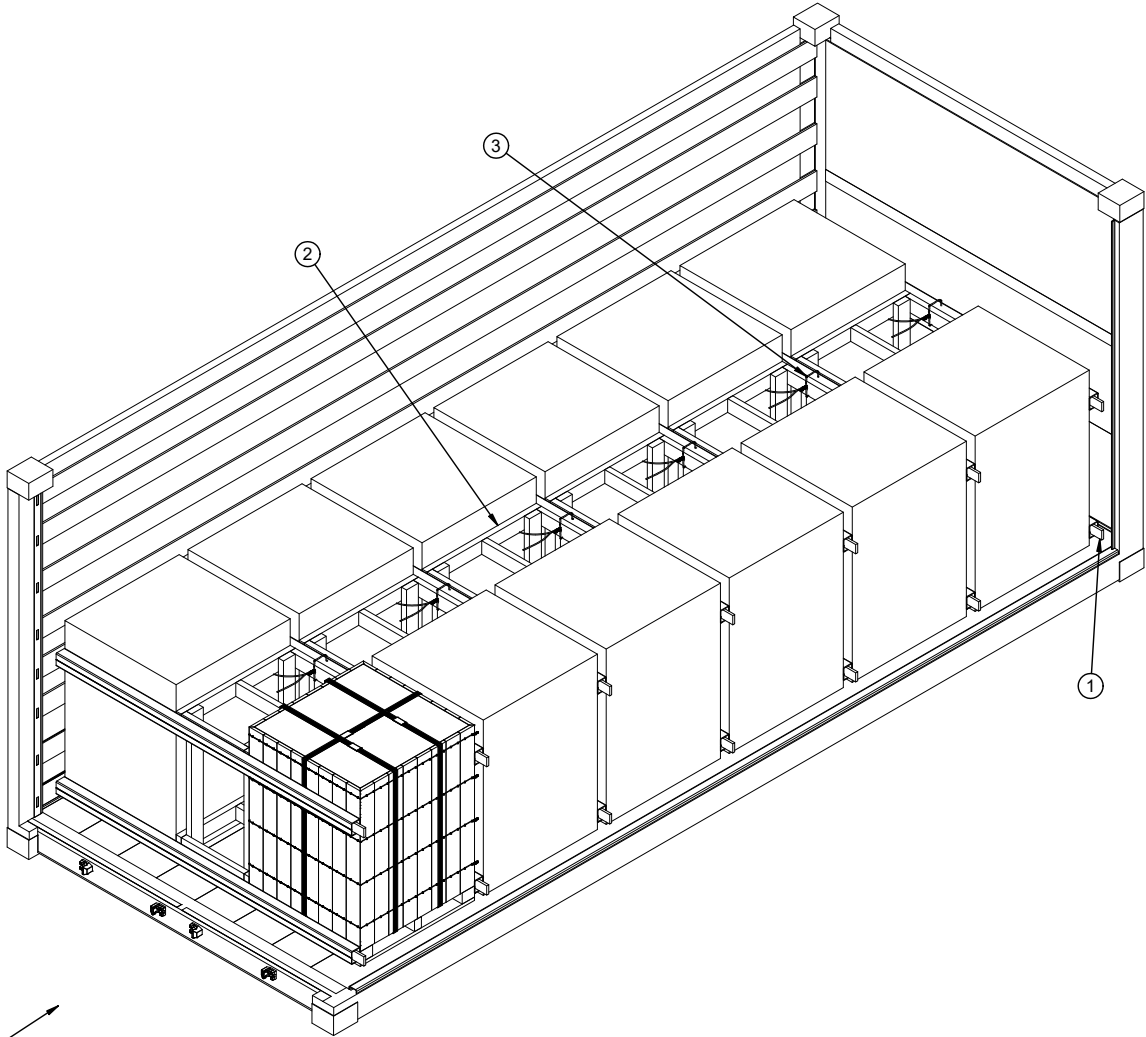

REAR OF CONTAINER →

ISOMETRIC VIEW

KEY NUMBERS

- ① CROSS MEMBER (14 REQD). POSITION AS SHOWN IN THE DETAIL ABOVE AT THE 5" AND 38" HEIGHTS. SEE THE "FILL DETAIL" ON PAGE 6.
- ② CENTER FILL ASSEMBLY (6 REQD). SEE "CENTER FILL ASSEMBLY" ON PAGE 5.
- ③ TIE WIRE, 0.080" DIAMETER BY 24" (6 REQD, 1 PER CENTER FILL ASSEMBLY). INSTALL TO FORM A COMPLETE LOOP AROUND THE ASSEMBLY AND AN ADJACENT PALLET UNIT STRAP OR CROSSMEMBER. BRING ENDS TOGETHER AND TWIST TAUT. SEE THE FILL DETAIL ON PAGE 6.

BILL OF MATERIAL

LUMBER	LINEAR FEET	BOARD FEET
2" X 4"	199	133
NAI LS	NO. REQD	POUNDS
10d (3")	288	4-1/2
WI RE, 0.080" DIA	24' REQD	1/2 LB
CROSS MEMBER	14 REQD	

LOAD AS SHOWN

ITEM	QUANTITY	WEIGHT (APPROX)
PALLET BOX	12	26,868 LBS
DUNNAGE		270 LBS
CONTAINER		5,700 LBS
TOTAL WEIGHT		32,837 LBS (APPROX)

GENERAL NOTES

- A. THIS DOCUMENT HAS BEEN PREPARED AND ISSUED IN ACCORDANCE WITH AR 740-1 AND AUGMENTS TM 743-200-1 (CHAPTER 5).
- B. THE SPECIFIED OUTLOADING PROCEDURES ARE APPLICABLE TO LOADS OF 105MM CARTRIDGES PACKED IN PA71 FIBER CONTAINERS IN WIREBOUND PALLET BOX. SUBSEQUENT REFERENCE TO PALLET BOX HEREIN MEANS PALLET BOX WITH AMMUNITION ITEMS. SEE ARDEC DRAWING 9277353 AND PAGE 4 FOR DETAILS OF THE PALLET BOX. **CAUTION:** REGARDLESS OF THE QUANTITY OF UNITS TO BE SHIPPED, THE "MAXIMUM GROSS WEIGHT" OF THE MILVAN CONTAINER MUST NOT BE EXCEEDED.
- C. THE LOADS AS SHOWN ARE BASED ON A 20' LONG BY 8' WIDE BY 8' HIGH MILVAN CONTAINER WITH INSIDE DIMENSIONS OF 19'-4" LONG BY 92" WIDE BY 87" HIGH. THE LOADS ARE DESIGNED FOR TRAILER/CONTAINER-ON-FLATCAR (T/COFC) SHIPMENT.
- D. THE SPECIFIED OUTLOADING PROCEDURES ARE FOR CONTAINERS EQUIPPED WITH SELF-CONTAINED MECHANICAL BRACING DEVICES AS DESCRIBED IN MIL-C-52861. CROSS MEMBER ATTACHMENT FACILITIES WITHIN THESE CONTAINERS MUST PROVIDE FOR THE INSTALLATION OF LOAD BLOCKING CROSS MEMBERS AT THE HEIGHTS SPECIFIED. VOIDS LENGTHWISE WITHIN THE LOAD MUST BE HELD TO A MINIMUM. CROSS MEMBERS MUST BE PLACED AGAINST THE LADING AS TIGHTLY AS THE HOLE SPACING IN THE CROSS MEMBER ATTACHMENT FACILITY PERMITS. SEE THE "FILL DETAIL" ON PAGE 6 FOR ADDITIONAL GUIDANCE. EACH CROSS MEMBER WILL BE INSTALLED WITH THE ENDS ATTACHED AS NEARLY AS POSSIBLE IN "MATED" POSITIONS (AT EQUAL HEIGHTS, AND AT EQUAL DISTANCES FROM THE END OF THE CONTAINER). CROSS MEMBERS IN EMPTY CONTAINERS AND THOSE NOT USED IN LOADED CONTAINERS MUST BE FASTENED INTO BELT RAILS FOR SHIPMENT. COMPONENTS ASSIGNED TO EACH CONTAINER MUST REMAIN THEREWITH EVEN THOUGH UNUSED DURING SOME SHIPMENTS. THE LOAD BLOCKING COMPONENT DESIGNATED AS "CROSS MEMBER" HEREIN IS IDENTIFIED AS "BEAM ASSEMBLY" WITHIN TM 55-8115-200-23&P, DATED DECEMBER 1979. THE BEAM ASSEMBLY IS FURTHER IDENTIFIED AS NSN 8115-00-165-6623.
- E. WHEN LOADING PALLET BOXES, THEY ARE TO BE POSITIONED SO AS TO ACHIEVE A TIGHT LOAD (TIGHT AGAINST THE DUNNAGE ASSEMBLIES). THE UNBLOCKED SPACE ACROSS THE WIDTH OF A LOAD BAY IS NOT TO EXCEED 1-1/2". EXCESSIVE SLACK CAN BE ELIMINATED BY ADJUSTING THE LENGTH OF THE STRUTS IN THE CENTER FILL ASSEMBLY, AS NECESSARY, TO FACILITATE VARIANCE IN THE PALLET BOX SIZE.
- F. DUNNAGE LUMBER SPECIFIED IS OF NOMINAL SIZE. FOR EXAMPLE, 1" X 4" MATERIAL IS ACTUALLY 3/4" THICK BY 3-1/2" WIDE AND 2" X 6" MATERIAL IS ACTUALLY 1-1/2" THICK BY 5-1/2" WIDE.
- G. A STAGGERED NAILING PATTERN WILL BE USED WHENEVER POSSIBLE WHEN NAILS ARE DRIVEN INTO JOINTS OF DUNNAGE ASSEMBLIES OR WHEN LAMINATING DUNNAGE. ADDITIONALLY, THE NAILING PATTERN FOR AN UPPER PIECE OF LAMINATED DUNNAGE WILL BE ADJUSTED AS REQUIRED SO THAT A NAIL FOR THAT PIECE WILL NOT BE DRIVEN THROUGH ONTO OR RIGHT BESIDE A NAIL IN A LOWER PIECE.
- H. **CAUTION:** DO NOT NAIL DUNNAGE MATERIAL TO THE MILVAN WALLS OR FLOOR. ALL NAILING WILL BE WITHIN THE DUNNAGE.
- J. PORTIONS OF THE MILVAN DEPICTED WITHIN THIS DRAWING, SUCH AS ONE OF THE SIDEWALLS, HAVE NOT BEEN SHOWN IN THE LOAD VIEWS FOR CLARITY PURPOSES.
- K. **MAXIMUM LOAD WEIGHT CRITERIA:**
THE MAXIMUM LOAD WEIGHTS ARE CONTROLLED BY EQUIPMENT CAPABILITY FACTORS. ALTHOUGH THE HEAVIEST MAXIMUM LOADS ARE DELINEATED IN THE LOAD VIEWS, PROVISIONS ARE INCLUDED WITHIN THIS DRAWING SO THAT THE BASIC LOADS CAN BE ADJUSTED TO SATISFY A LESSER QUANTITY OF LADING UNITS. DEPENDING ON TRANSPORTATION ROUTING, IT MAY BE NECESSARY TO REDUCE THE LOAD WEIGHT TO SATISFY "WEIGHT LAWS" OF CERTAIN STATES. ALSO, IT MAY BE NECESSARY TO REDUCE THE LOAD WEIGHT TO SATISFY OTHER WEIGHT RESTRICTIONS IMPOSED ON THE INTERMODAL CONTAINER SYSTEM.
- L. REQUIREMENTS CITED WITHIN THE ASSOCIATION OF AMERICAN RAILROADS (AAR) INTERMODAL LOADING GUIDE APPLY WHEN THE SHIPMENT MOVES BY TRAILER/CONTAINER-ON-FLATCAR (T/COFC). SPECIAL T/COFC NOTES FOLLOW:
1. **CAUTION:** LOADED CONTAINERS MUST BE ON CHASSIS EQUIPPED WITH TWO BOGIE ASSEMBLIES WHEN BEING MOVED IN TOFC SERVICE, REGARDLESS OF THE LOAD WEIGHT WITHIN THE CONTAINER.
 2. LOAD LIMITS OF T/COFC RAIL CARS MUST NOT BE EXCEEDED, NOR WILL A CAR BE LOADED SO THAT THE TRUCK UNDER ONE END OF THE CAR CARRIES MORE THAN ONE-HALF OF THE LOAD LIMIT FOR THAT CAR.
 3. CHASSIS/CONTAINERS COUPLED INTO A 40-FOOT TRAILER CONFIGURATION MUST BE PLACED AT THE B-END OF A TOFC RAILCAR. THE REAR END OF THE 40-FOOT UNIT WILL OVERHANG THE END OF THE CAR IF IT IS PLACED AT THE A-END. TWENTY-FOOT AND 40-FOOT UNITS CAN BE LOADED ON THE SAME CAR.

(CONTINUED AT RIGHT)

(GENERAL NOTES CONTINUED)

- M. WHETHER A CONTAINER IS FULL OR IS LOADED WITH A REDUCED QUANTITY OF LADING UNITS, THE LENGTHWISE CENTER OF GRAVITY OF THE LOAD MUST BE WITHIN 12", IN EITHER DIRECTION, OF THE MID-POINT OF THE CONTAINER.
- N. THE QUANTITY OF PALLET BOXES SHOWN IN THE LOAD ON PAGE 2 MAY BE REDUCED FOR SHIPMENT, IF DESIRED. SEE THE "LESS-THAN- FULL LOAD" DETAIL ON PAGE 6.
1. IF A LOAD IS REDUCED BY ONLY A SMALL AMOUNT (ONE OR TWO LADING UNITS), LADING UNITS NORMALLY MAY BE ELIMINATED FROM THE REAR OF THE LOAD.
 2. IF A LOAD IS REDUCED BY A LARGE AMOUNT (MORE THAN TWO LADING UNITS), LADING UNITS SHOULD BE ELIMINATED AS REQUIRED AND THE TOTAL LOAD SHIFTED FORE OR AFT, AS NECESSARY, TO ACHIEVE A SYMMETRICAL WEIGHT DISTRIBUTION. THE DEPICTED PROCEDURES WILL BE FOLLOWED AS CLOSELY AS POSSIBLE, MAKING ONLY THOSE ADJUSTMENTS TO THE DUNNAGE WHICH ARE REQUIRED TO ACCOMMODATE THE NUMBER OF UNITS TO BE SHIPPED.
- O. CONVERSION TO METRIC EQUIVALENTS: DIMENSIONS WITHIN THIS DOCUMENT ARE EXPRESSED IN INCHES, AND WEIGHTS ARE EXPRESSED IN POUNDS. WHEN NECESSARY, THE METRIC EQUIVALENTS MAY BE COMPUTED ON THE BASIS OF ONE INCH EQUALS 25.4MM AND ONE POUND EQUALS 0.454 KG.

MATERIAL SPECIFICATIONS

- LUMBER** - - - - - : SEE TM 743-200-1 (DUNNAGE LUMBER) AND VOLUNTARY PRODUCT STANDARD PS 20.
- NAILS** - - - - - : ASTM F1667; COMMON STEEL NAIL (NLCMS OR NLCMMS).
- WIRE, CARBON STEEL** - - : ASTM A853; ANNEALED AT FINISH, BLACK OXIDE FINISH, 0.0800" DIA, GRADE 1006 OR BETTER.

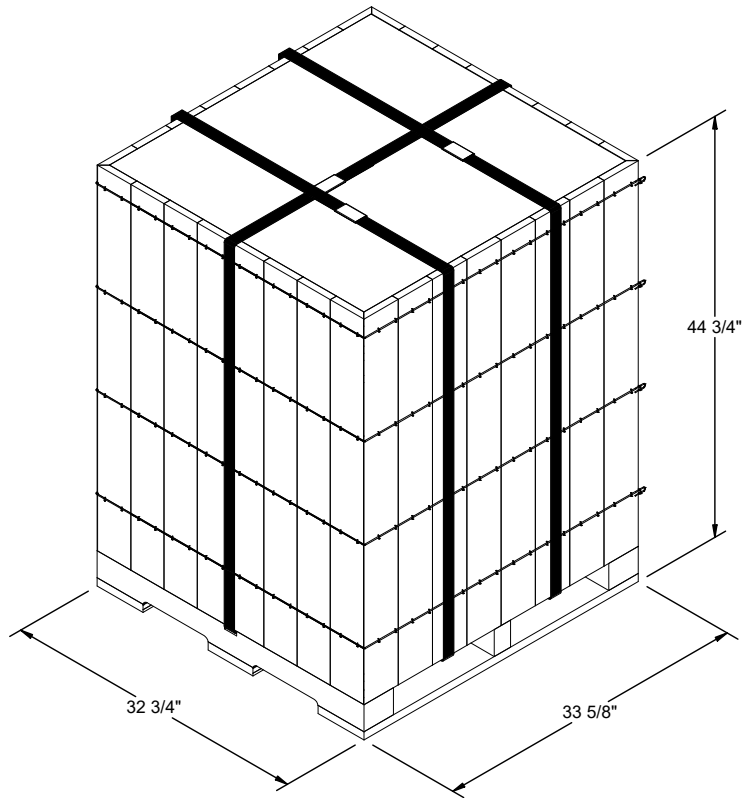

PALLET UNIT DATA

GROSS WEIGHT - - - - - 2,239 LBS (APPROX)
 CUBE - - - - - 28.5 CU FT (APPROX)

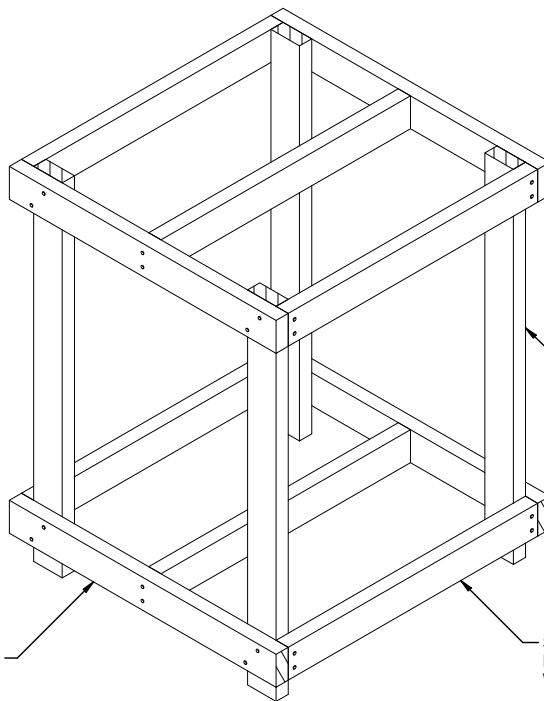

BUFFER PIECE, 2" X 4" X 32-3/4"
 (4 REQD). NAIL TO THE VERTICAL
 PIECES AND CENTER STRUT
 PIECES W/2-10d NAIL AT EACH JOINT.

VERTICAL PIECE, 2" X
 4" X 42" (4 REQD).

STRUT, 2" X 4" x 30-5/8" (6 REQD).
 NAIL STRUTS TO VERTICAL PIECES
 W/2-10d NAILS AT EACH END.

FILLER ASSEMBLY

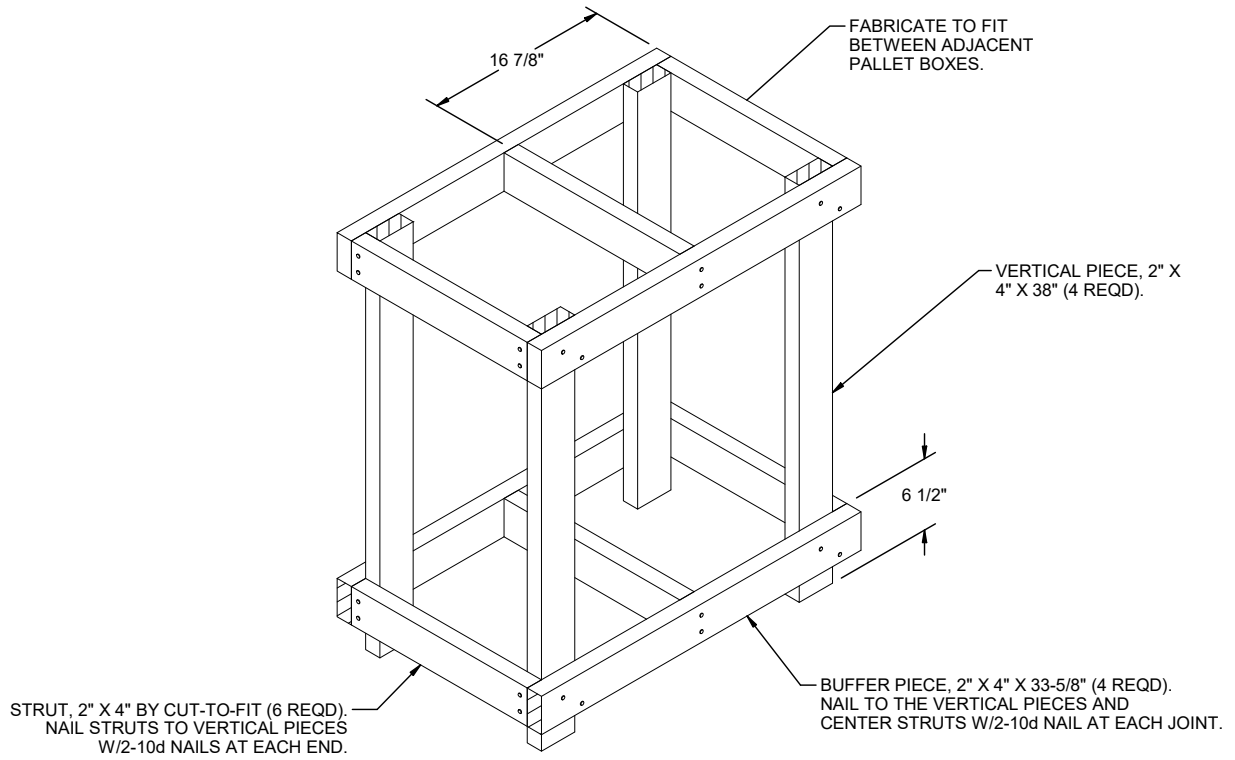

CENTER FILL ASSEMBLY

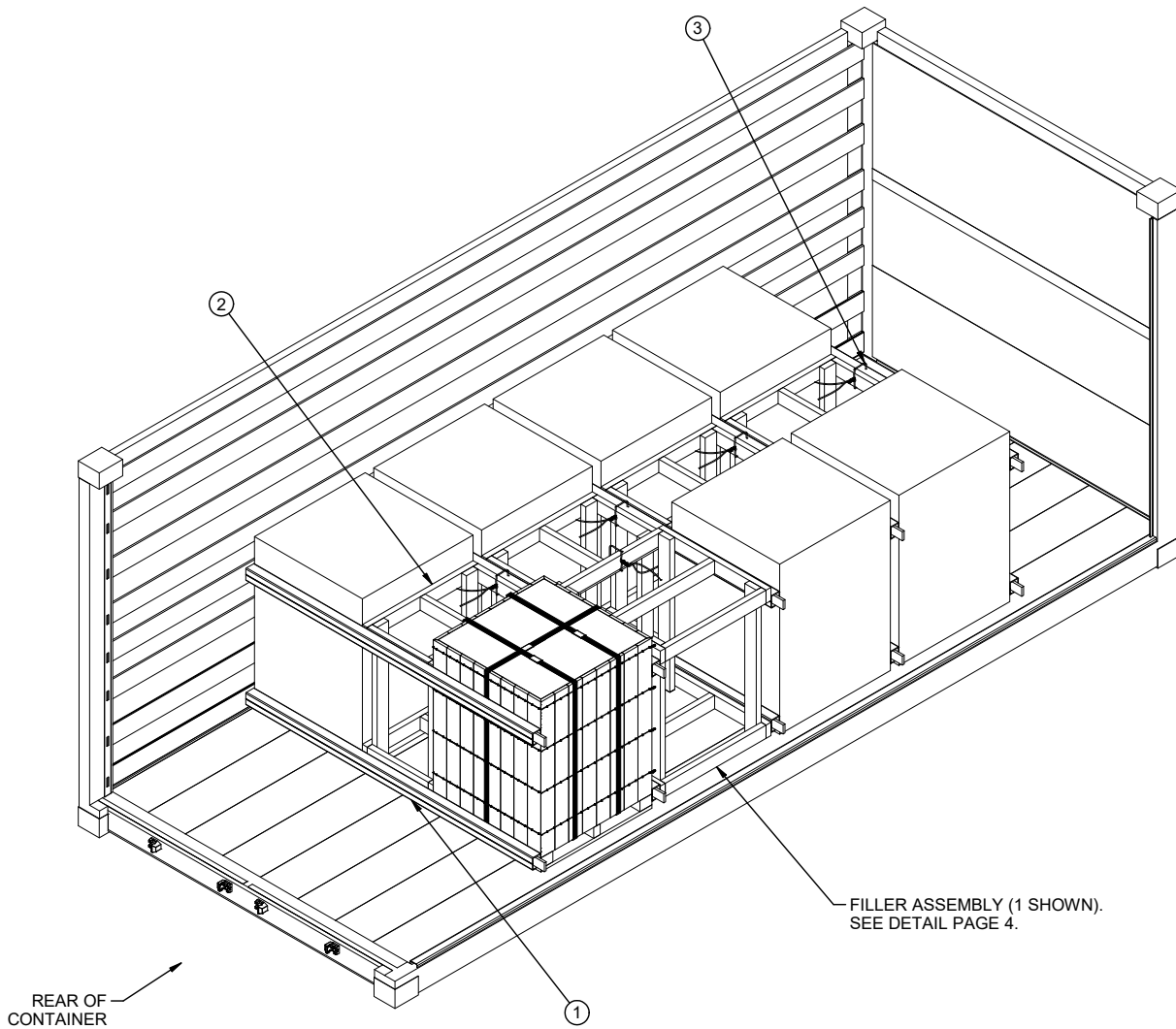

LESS-THAN-FULL-LOAD PROCEDURE

KEY NUMBERS REFER TO KEY NUMBERS ON PAGE 2. SEE GENERAL NOTES "M" AND "N" ON PAGE 3.

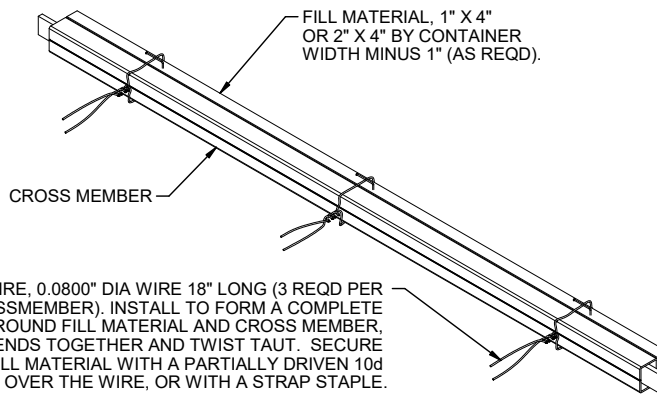

FILL DETAIL

THIS DETAIL DEPICTS THE METHOD OF POSITIONING FILL MATERIAL BETWEEN CROSS MEMBER AND LADING, WHEN THE VOID BETWEEN THE TWO IS GREATER THAN 1".